



US00D512668S

(12) **United States Design Patent** (10) **Patent No.:** **US D512,668 S**  
**Preiss** (45) **Date of Patent:** **\*\* Dec. 13, 2005**

(54) **SURFACE CONFIGURATION OF A VEHICLE SPOILER**

*Primary Examiner*—Stacia Cadmus  
(74) *Attorney, Agent, or Firm*—Crowell & Moring LLP

(75) **Inventor:** **Michael Preiss**, Vaihingen (DE)

(57) **CLAIM**

(73) **Assignee:** **Dr. Ing. h.c.F. Porsche Aktiengesellschaft**, Stuttgart (DE)

The ornamental design for a surface configuration of a vehicle spoiler, as shown and described.

(\*\*) **Term:** **14 Years**

**DESCRIPTION**

(21) **Appl. No.:** **29/223,444**

FIG. 1 is a top perspective view of a first embodiment of a surface configuration of a vehicle spoiler according to my novel design;

(22) **Filed:** **Feb. 15, 2005**

FIG. 2 is a right side perspective view of the first embodiment of the surface configuration of a vehicle spoiler according to my novel design, the left side perspective view being mirror symmetrical;

(30) **Foreign Application Priority Data**

Aug. 27, 2004 (EM) ..... 000221189  
Aug. 27, 2004 (EM) ..... 000221221

FIG. 3 is a right side view of the first embodiment of the surface configuration of a vehicle spoiler according to my novel design, the left side view being mirror symmetrical;

(51) **LOC (6) Cl.** ..... **12-08**

(52) **U.S. Cl.** ..... **D12/181**

FIG. 4 is a top perspective view of a second embodiment of the surface configuration of a vehicle spoiler according to my novel design;

(58) **Field of Search** ..... D12/181, 191,  
D12/196, 400; 160/133, 161, DIG. 1; 280/848;  
296/180.1–180.5, 280.3, 208, 82; 180/903

FIG. 5 is a right side perspective view of the second embodiment of the surface configuration of a vehicle spoiler according to my novel design, the left side perspective view being mirror symmetrical; and,

(56) **References Cited**

**U.S. PATENT DOCUMENTS**

D420,314 S \* 2/2000 Kulla et al. .... D12/181  
D433,976 S \* 11/2000 Hatter ..... D12/181  
D435,817 S \* 1/2001 Lai ..... D12/181  
D441,331 S \* 5/2001 Hatter ..... D12/181  
D487,040 S \* 2/2004 Iwata ..... D12/181  
D491,121 S \* 6/2004 Yokomaku ..... D12/181

FIG. 6 is a right side view of the second embodiment of the surface configuration of a vehicle spoiler according to my novel design, the left side view being mirror symmetrical. The broken lines are for illustrative purposes only and form no part of the claimed design.

\* cited by examiner

**1 Claim, 4 Drawing Sheets**

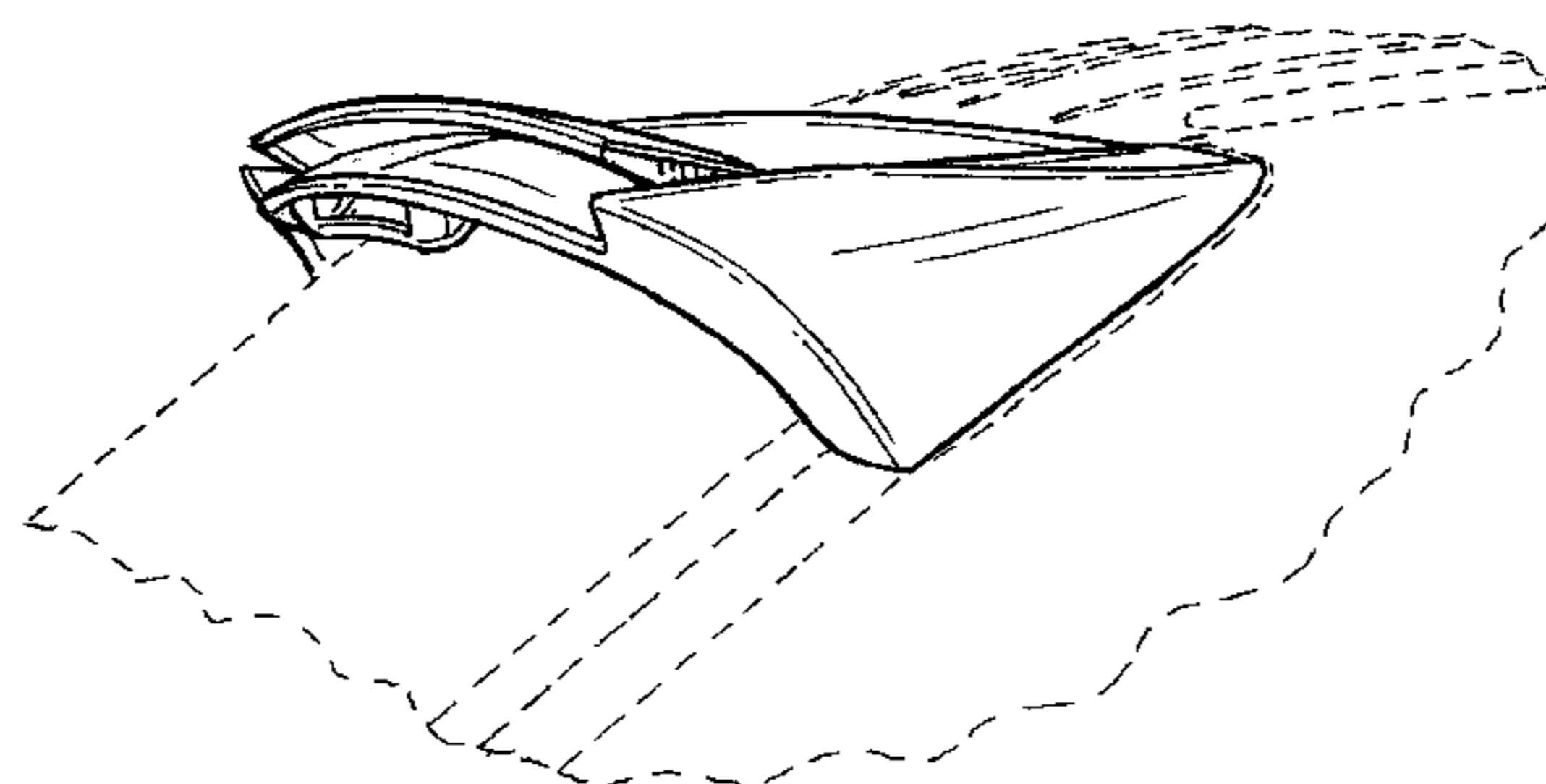
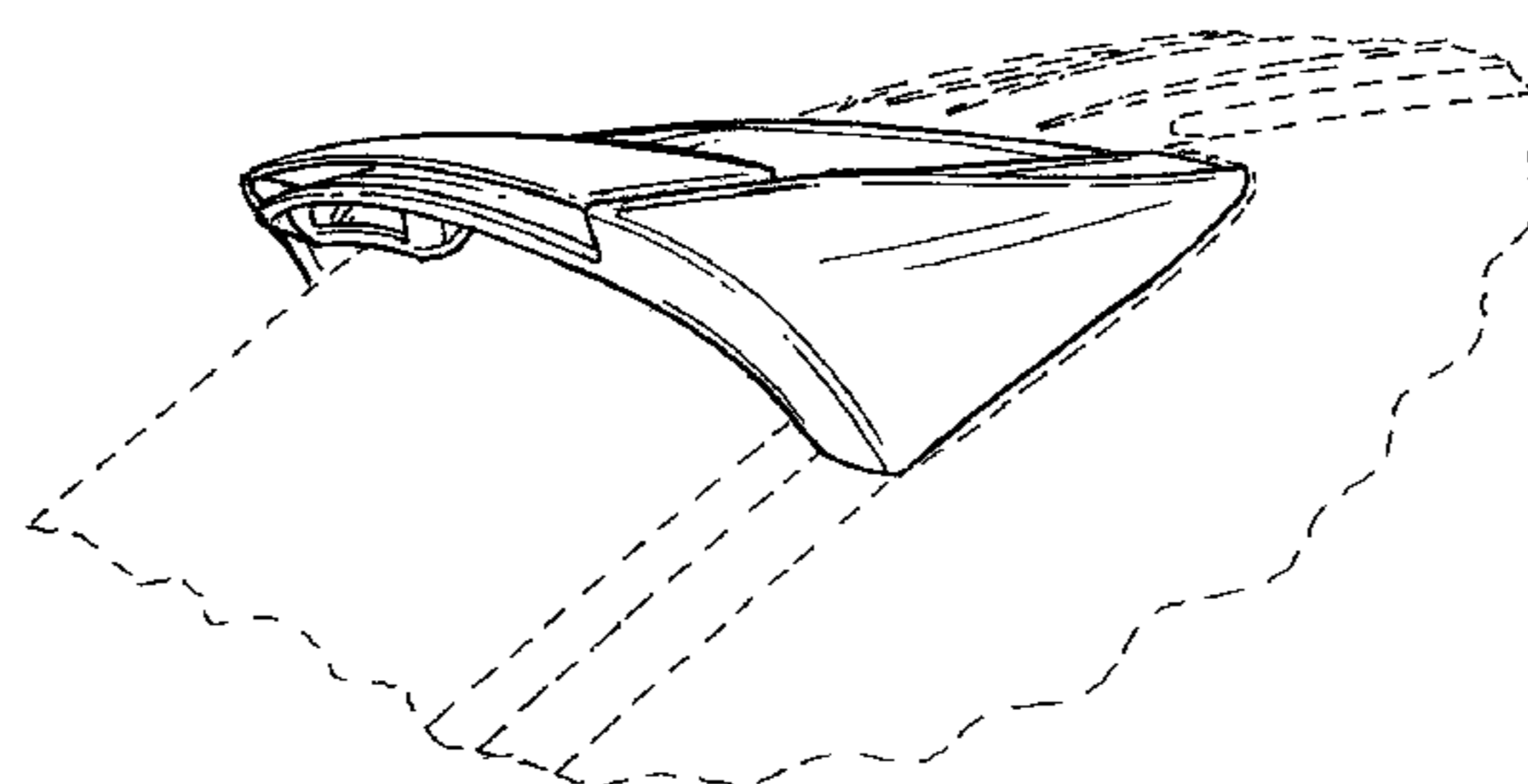

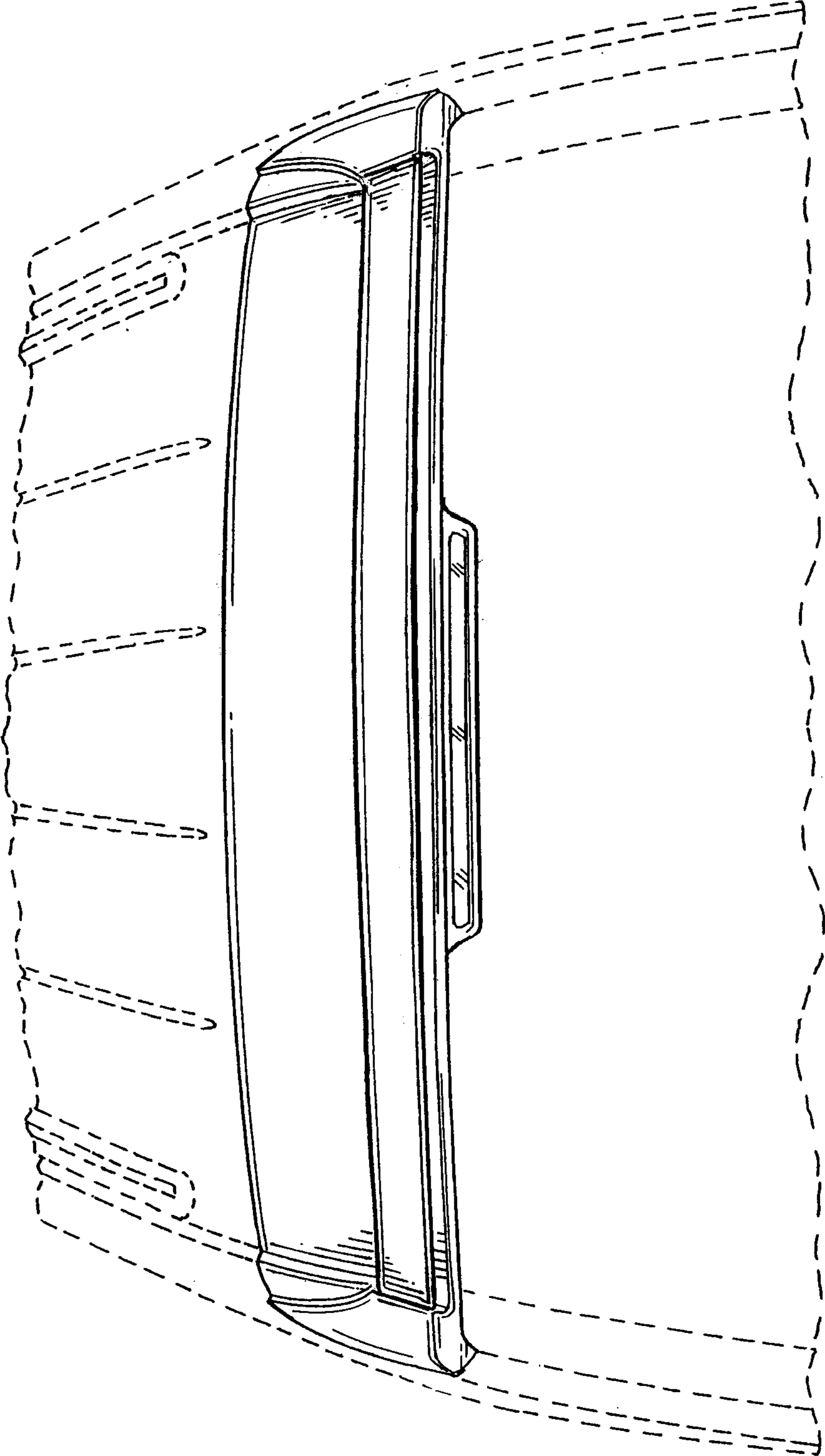

FIG. 1

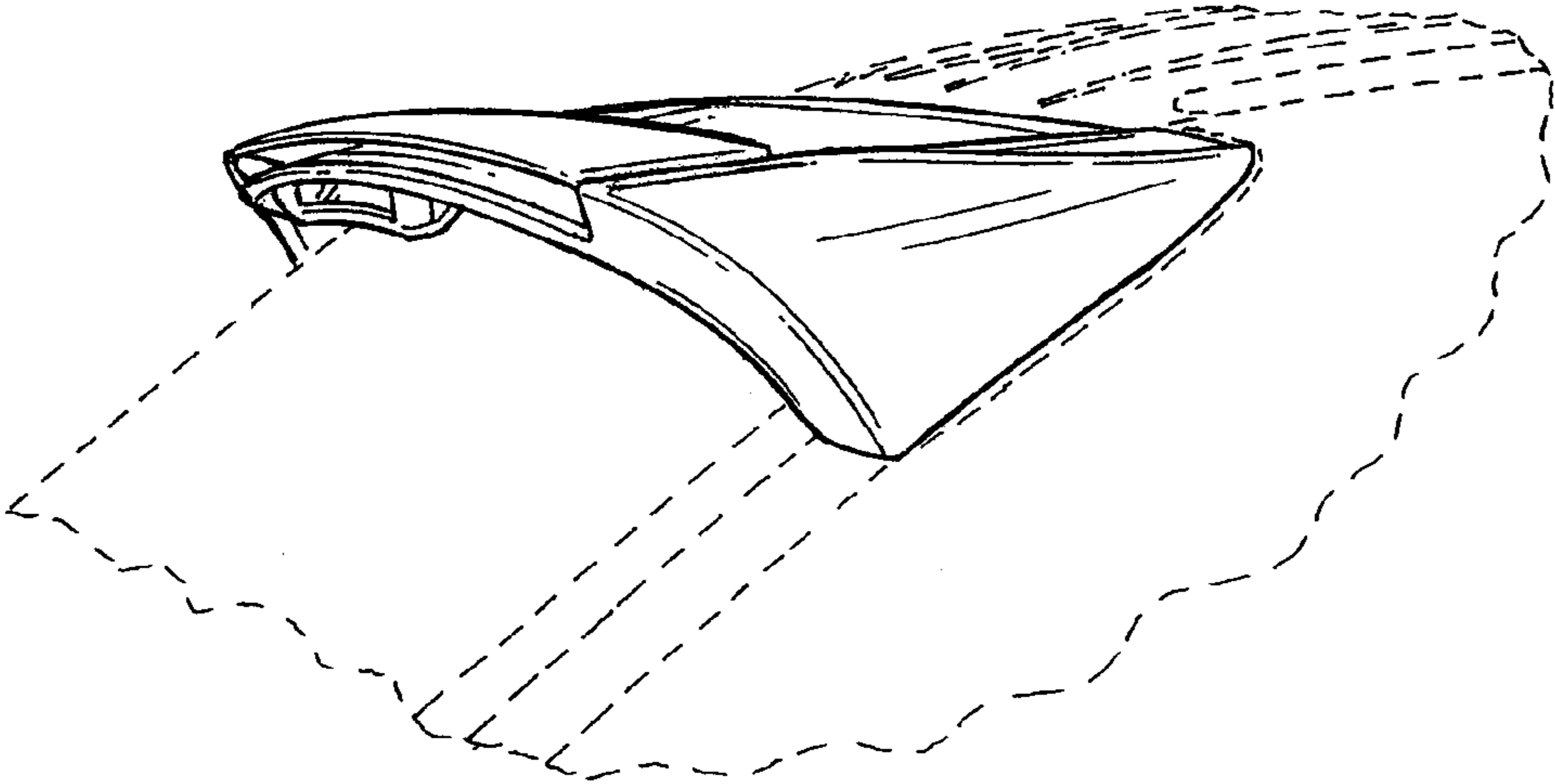

FIG. 2

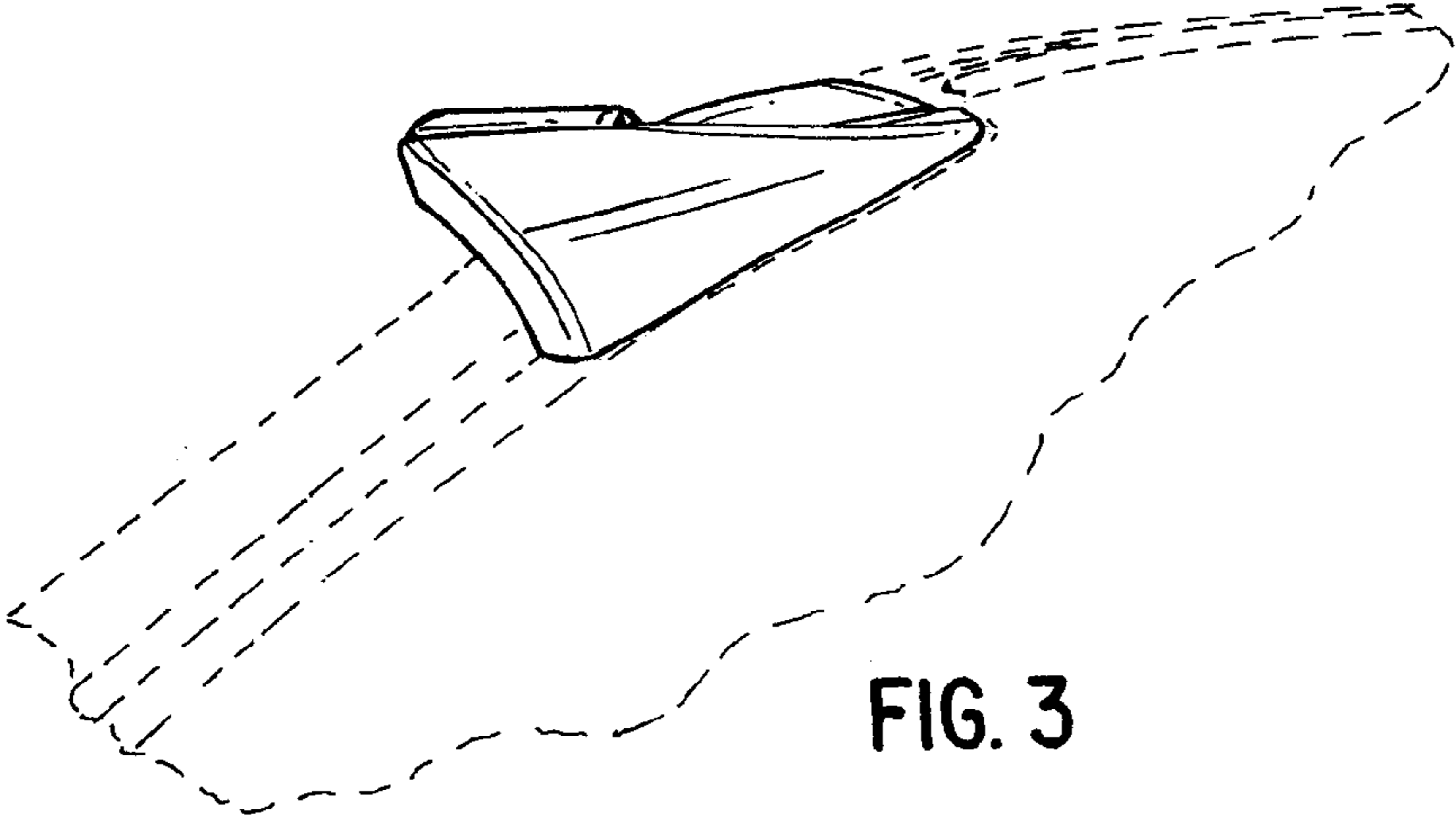

FIG. 3

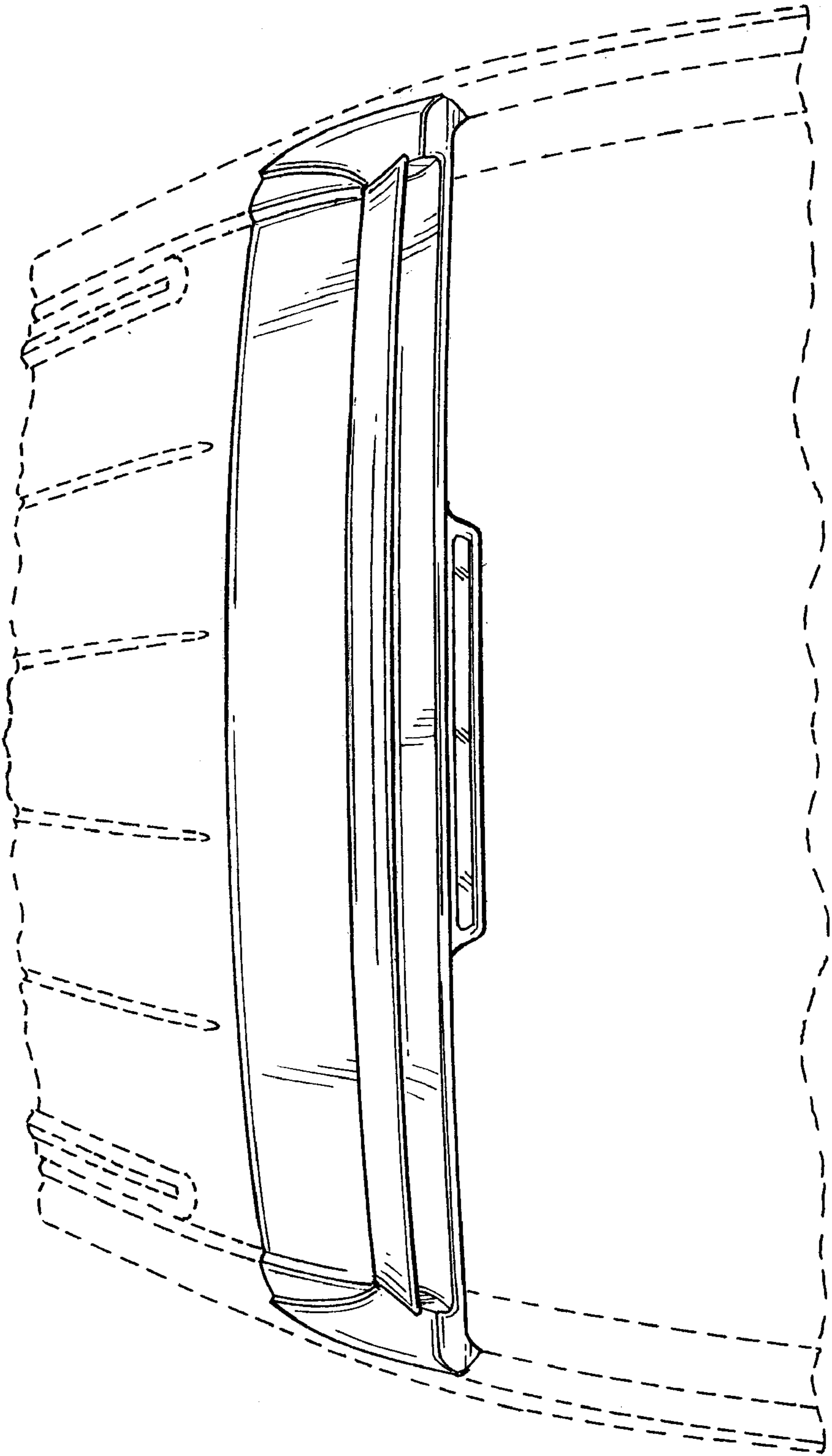

FIG. 4

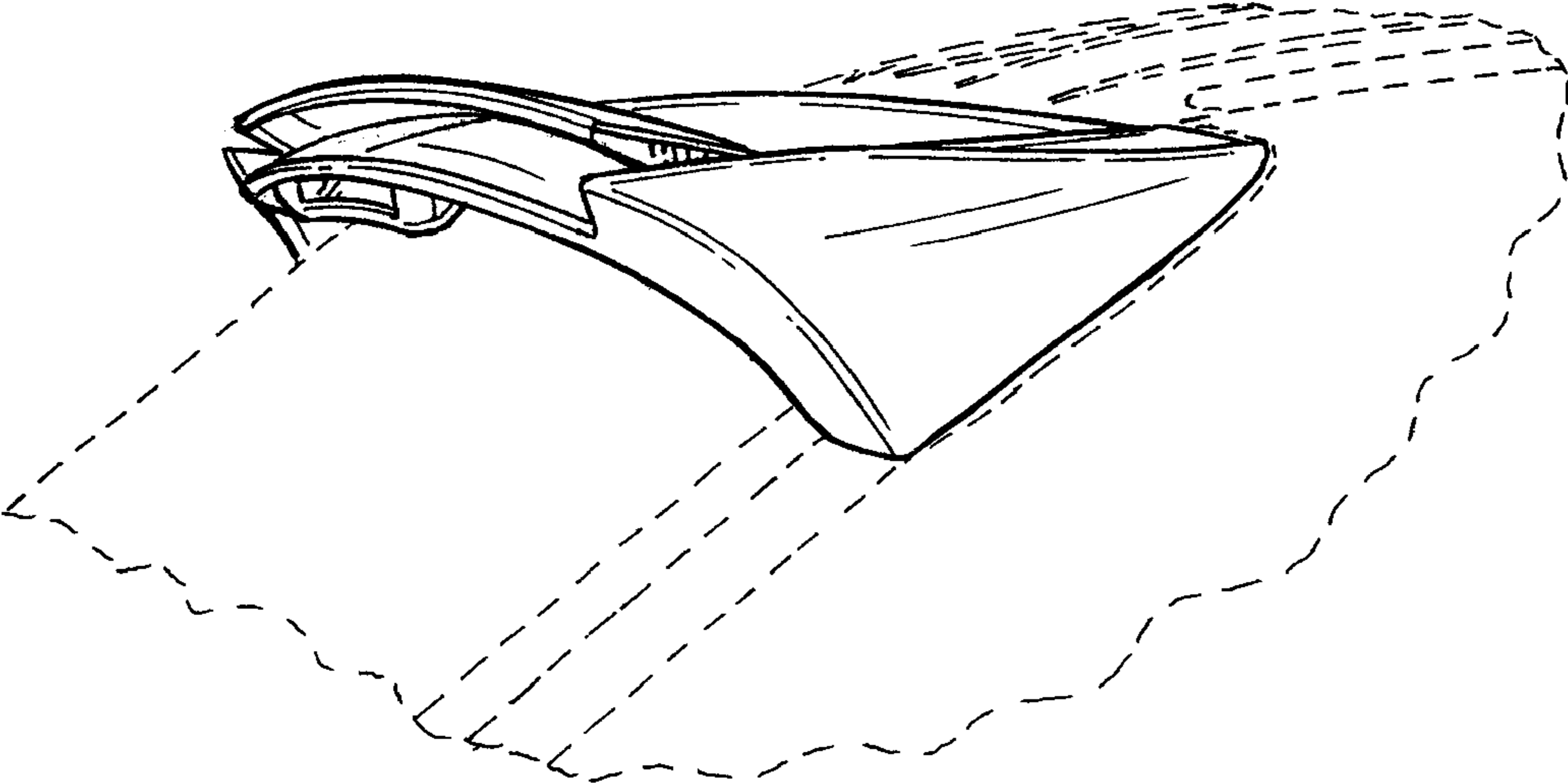

FIG. 5

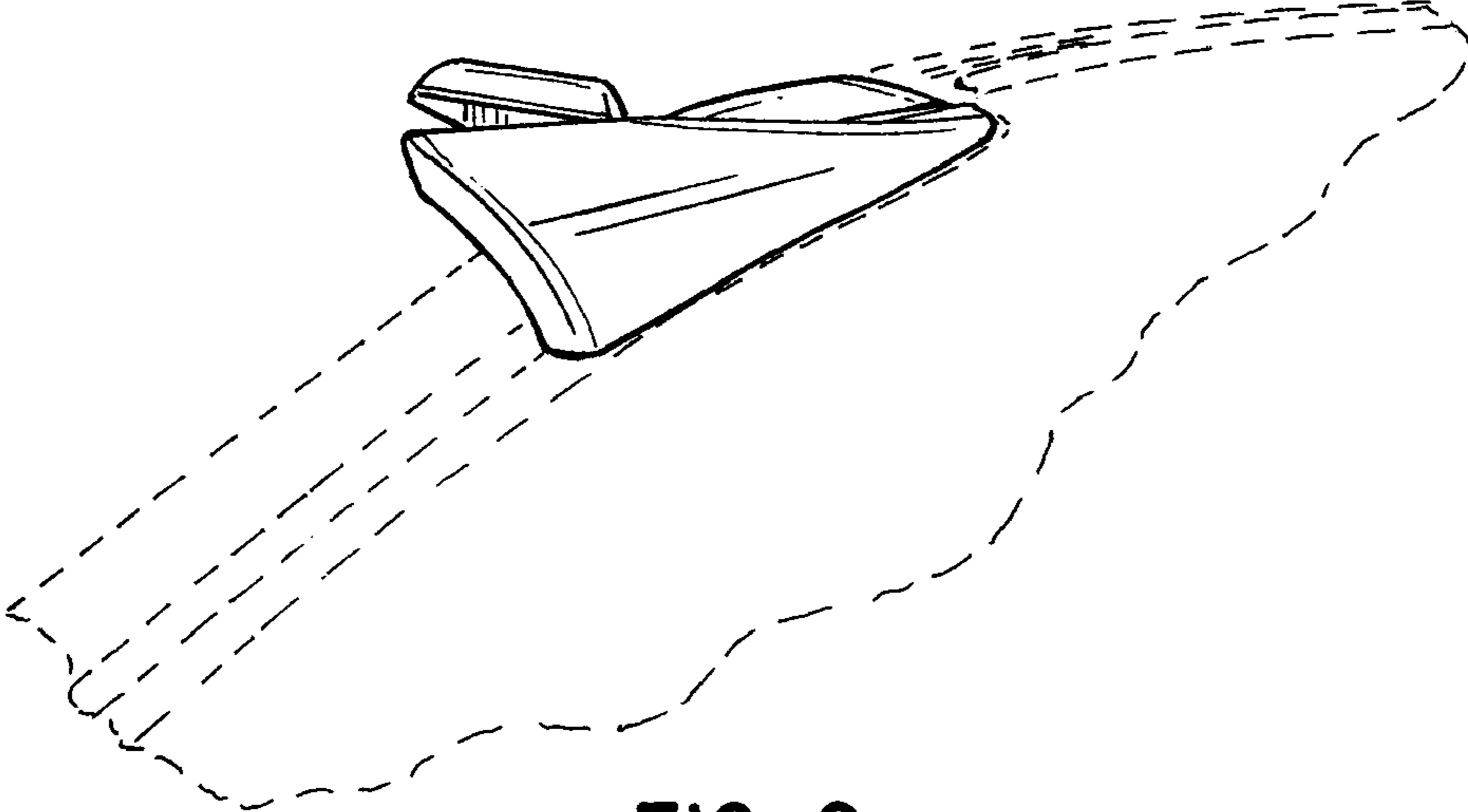

FIG. 6