



US00D512360S

(12) **United States Design Patent** (10) **Patent No.:** **US D512,360 S**  
**Boyer** (45) **Date of Patent:** **\*\* Dec. 6, 2005**

(54) **FRONT FACE OF A VEHICLE WHEEL**

D479,177 S \* 9/2003 Nordmann ..... D12/211  
D487,569 S \* 3/2004 Laengerer ..... D12/211  
D502,137 S \* 2/2005 Blum ..... D12/211

(75) Inventor: **Boyke Boyer**, Ismaning (DE)

(73) Assignee: **Bayerische Motoren Werke Aktiengesellschaft**, Munich (DE)

(\*\*) Term: **14 Years**

(21) Appl. No.: **29/178,641**

(22) Filed: **Mar. 31, 2003**

(30) **Foreign Application Priority Data**

Oct. 1, 2002 (DE) ..... 4 02 08 288

(51) **LOC (8) Cl.** ..... **12-16**

(52) **U.S. Cl.** ..... **D12/211**

(58) **Field of Search** ..... D12/204-213;  
301/37.101, 64.101, 65

(56) **References Cited**

**U.S. PATENT DOCUMENTS**

D360,179 S \* 7/1995 Fuller ..... D12/211  
D409,968 S 5/1999 Goplen ..... D12/211  
D466,852 S \* 12/2002 Pfeiffer et al. .... D12/211  
D476,284 S \* 6/2003 Pfeiffer et al. .... D12/211

**OTHER PUBLICATIONS**

Catalog: "LEXUS IS200/IS300 IS/300 Sport Cross," p. 56 (date unknown).

\* cited by examiner

*Primary Examiner*—Stacia Cadmus

(74) *Attorney, Agent, or Firm*—Crowell & Moring LLP

(57) **CLAIM**

The ornamental design for a front face of a vehicle wheel, as shown and described.

**DESCRIPTION**

FIG. 1 is a front view of a front face of a vehicle wheel according to my novel design; and,  
FIG. 2 is a perspective view of the front face of a vehicle wheel according to my novel design.  
The dash lines included depict environment and are not part of the claimed design. Also enclosed is a set of photographs of an embodiment of my invention.

**1 Claim, 1 Drawing Sheet**

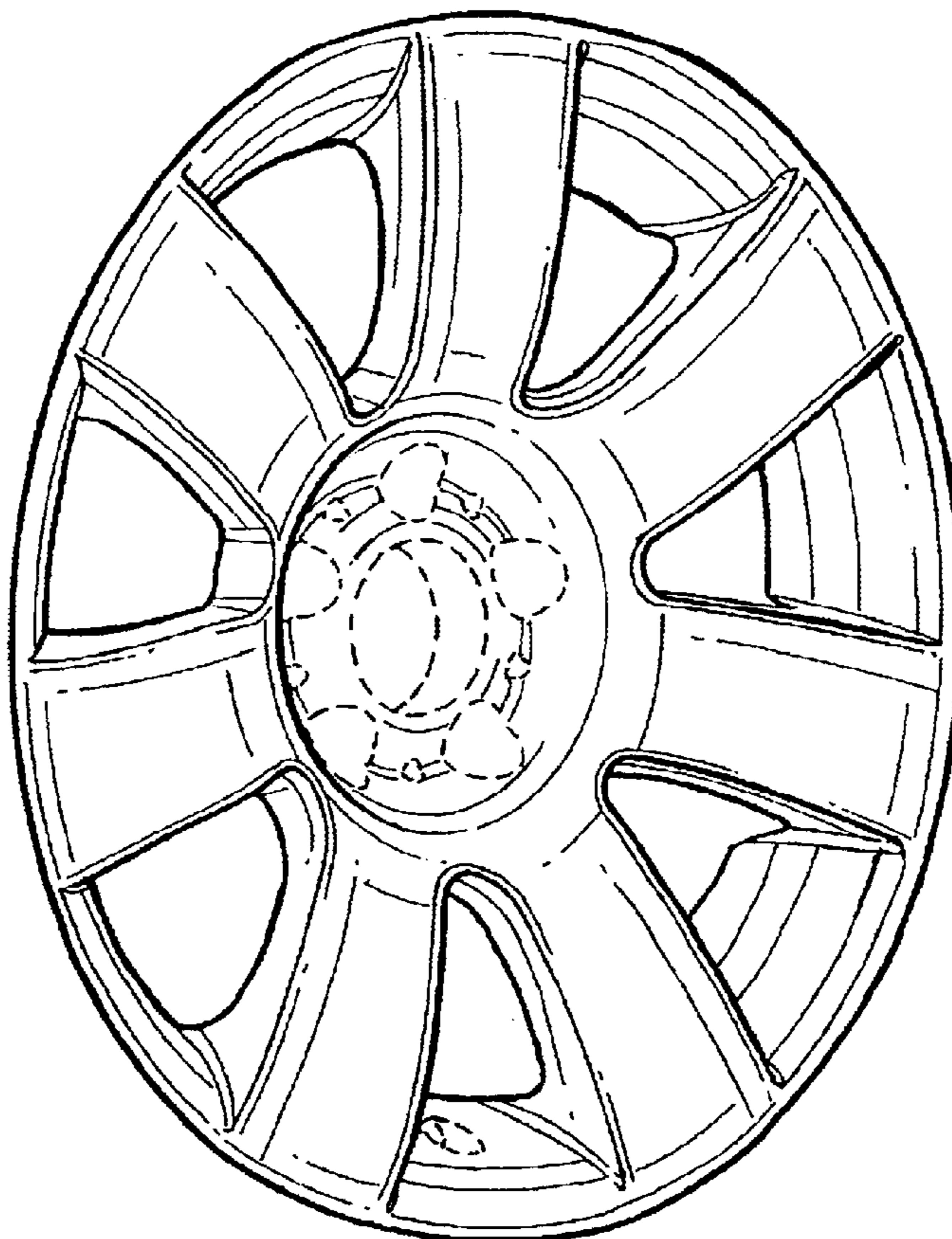

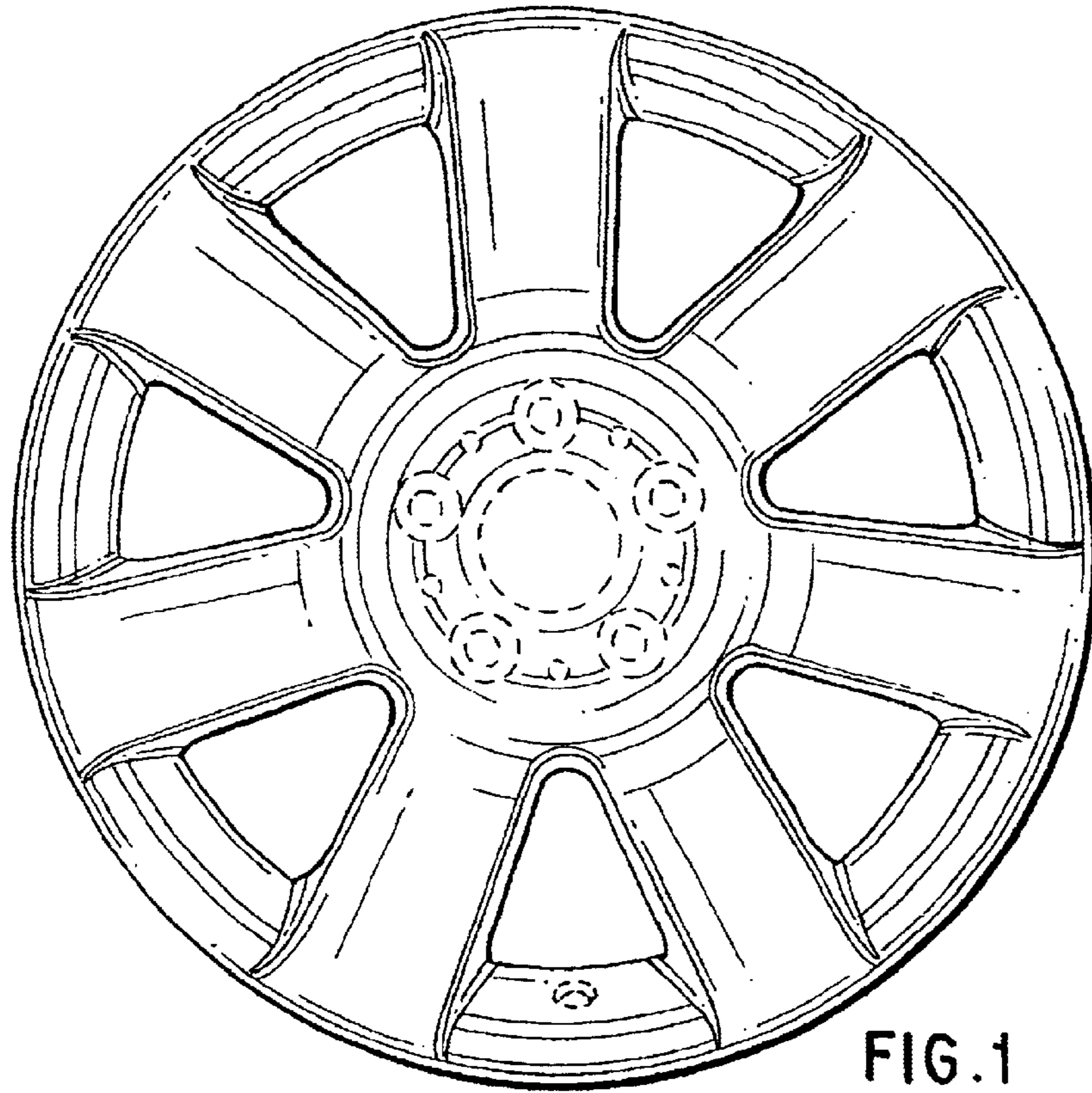

FIG. 1

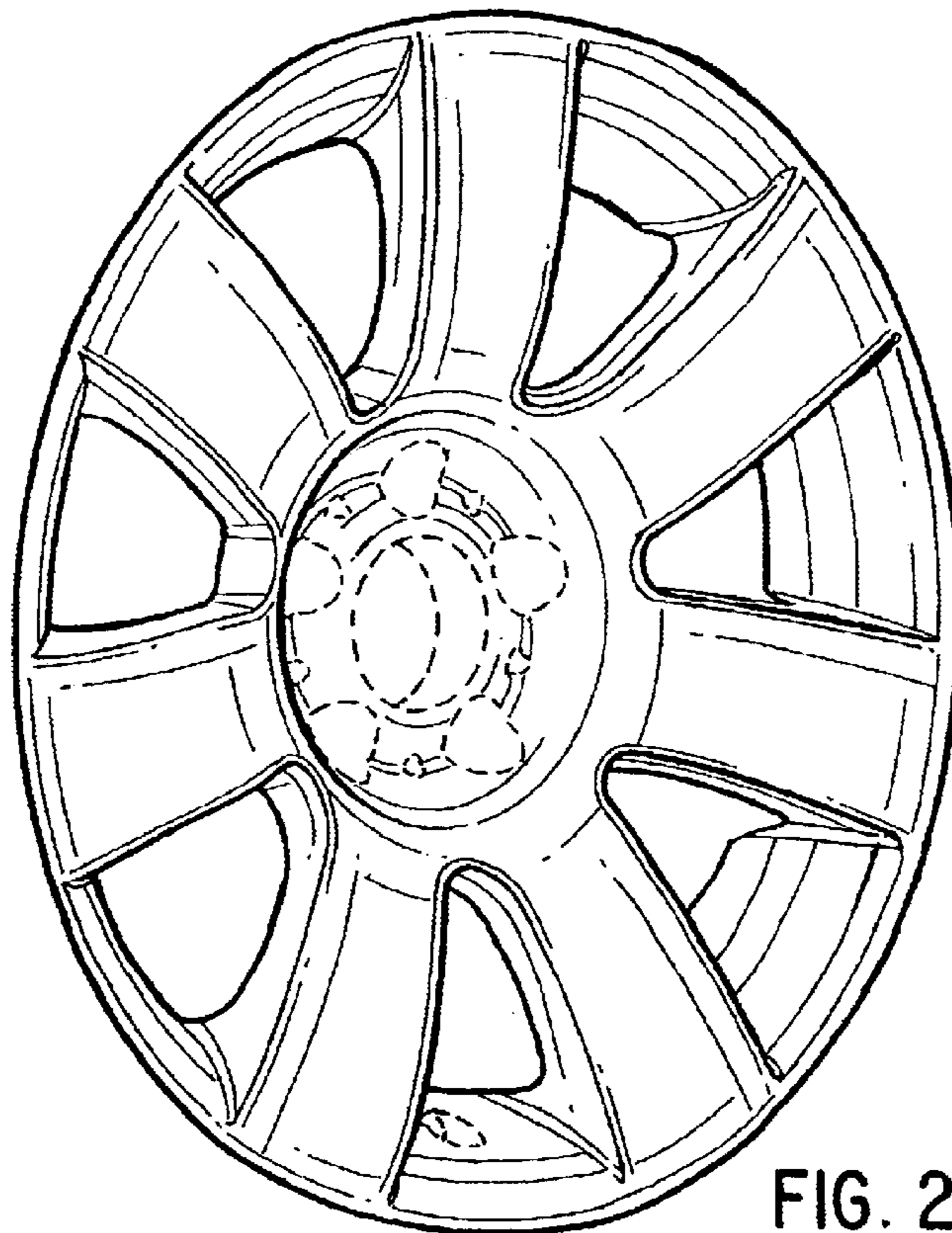

FIG. 2