



US00D511726S

(12) **United States Design Patent**
LeMond et al.

(10) **Patent No.: US D511,726 S**
(45) **Date of Patent: ** Nov. 22, 2005**

(54) **HANDLEBAR**

(75) Inventors: **Gregory J. LeMond**, Medina, MN (US); **Robert J. Bingham**, Everett, WA (US)

(73) Assignee: **LeMond Fitness Inc.**, Woodinville, WA (US)

(**) Term: **14 Years**

(21) Appl. No.: **29/200,896**

(22) Filed: **Mar. 5, 2004**

(51) **LOC (8) Cl.** **12-16**

(52) **U.S. Cl.** **D12/178**

(58) **Field of Search** D12/111, 178;
74/551.1-551.8; 280/274, 276, 279, 281.1,
288.1-288.3; D21/663-670, 694, 697; 482/57-65

(56) **References Cited**

U.S. PATENT DOCUMENTS

D323,805 S * 2/1992 Giard, Jr. D12/178
D332,768 S * 1/1993 Giard, Jr. D12/178
5,226,341 A * 7/1993 Shores 74/551.8

* cited by examiner

Primary Examiner—Alan P. Douglas

Assistant Examiner—Linda Brooks

(74) *Attorney, Agent, or Firm*—George C. Rondeau, Jr.;
Daivs Wright Tremaine LLP

(57) **CLAIM**

The ornamental design for a handlebar, as shown and described.

DESCRIPTION

FIG. 1 is a rear perspective view of a handlebar showing our new design.

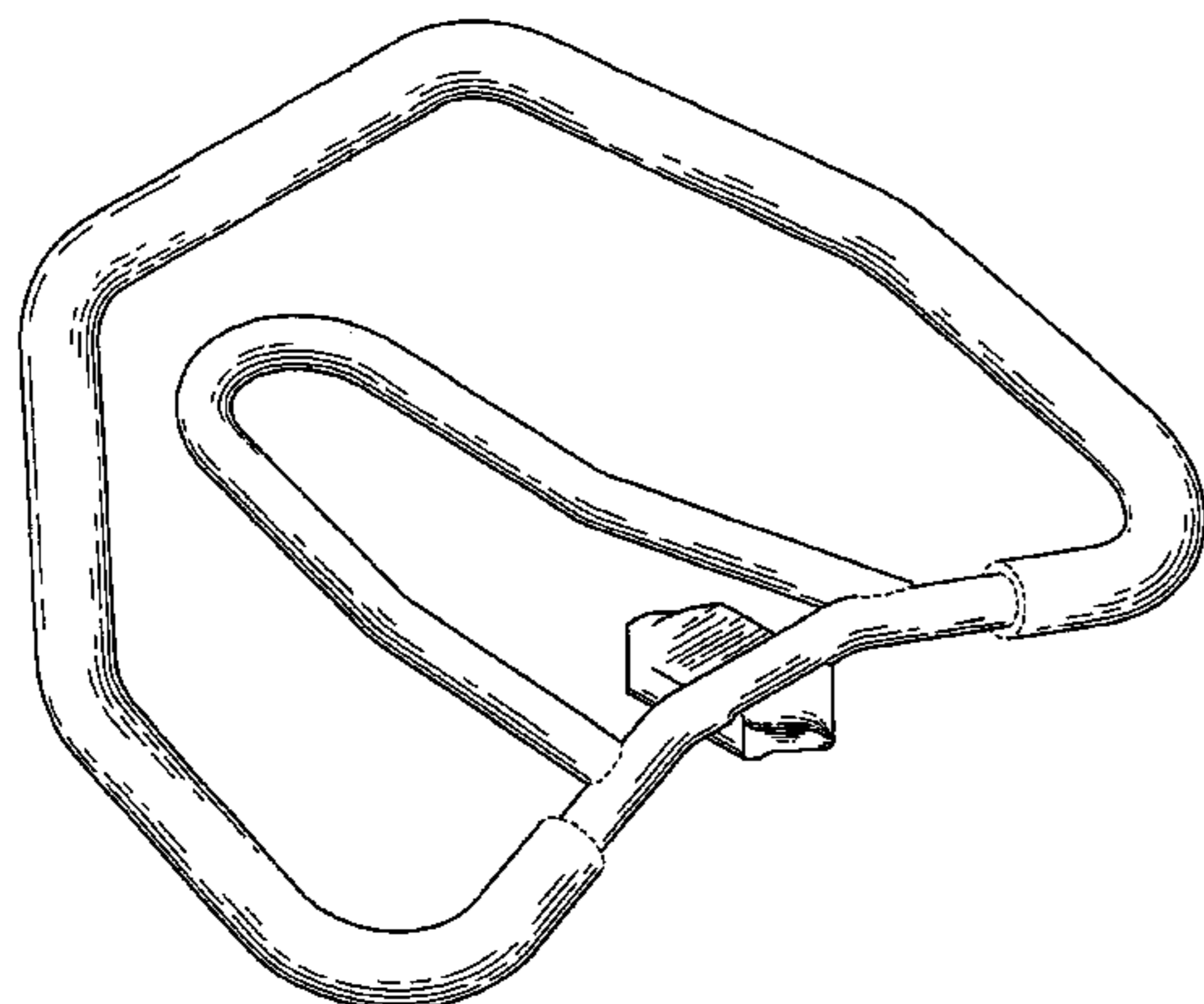

FIG. 2 is a top plan view thereof.

FIG. 3 is a bottom plan view thereof.

FIG. 4 is a front elevational view thereof.

FIG. 5 is a rear elevational view thereof.

FIG. 6 is a left side elevational view thereof.

FIG. 7 is a right side elevational view thereof.

FIG. 8 is a rear perspective view of a second embodiment thereof.

FIG. 9 is a top plan view thereof.

FIG. 10 is a bottom plan view thereof.

FIG. 11 is a front elevational view thereof.

FIG. 12 is a rear elevational view thereof.

FIG. 13 is a left side elevational view thereof.

FIG. 14 is a right side elevational view thereof.

FIG. 15 is a rear perspective view of a third embodiment thereof.

FIG. 16 is a top plan view thereof.

FIG. 17 is a bottom plan view thereof.

FIG. 18 is a front elevational view thereof.

FIG. 19 is a rear elevational view thereof.

FIG. 20 is a left side elevational view thereof.

FIG. 21 is a right side elevational view thereof.

FIG. 22 is a rear perspective view of a fourth embodiment thereof.

FIG. 23 is a top plan view thereof.

FIG. 24 is a bottom plan view thereof.

FIG. 25 is a front elevational view thereof.

FIG. 26 is a rear elevational view thereof.

FIG. 27 is a left side elevational view thereof; and,

FIG. 28 is a right side elevational view thereof.

The broken lines immediately adjacent the shaded areas represent the boundaries of the claimed design, while the other broken lines show environment; the broken lines form no part of the claimed design.

1 Claim, 20 Drawing Sheets

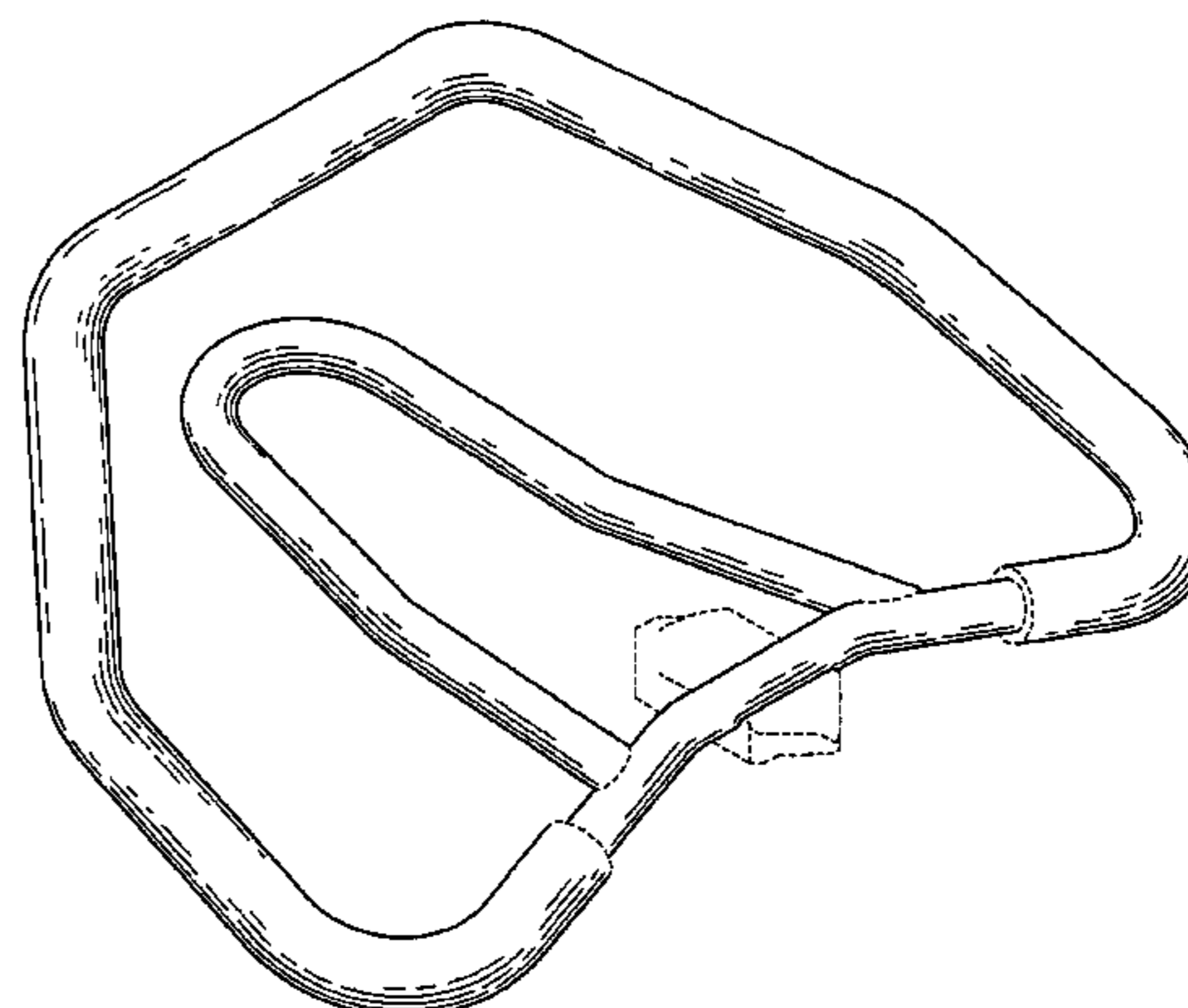

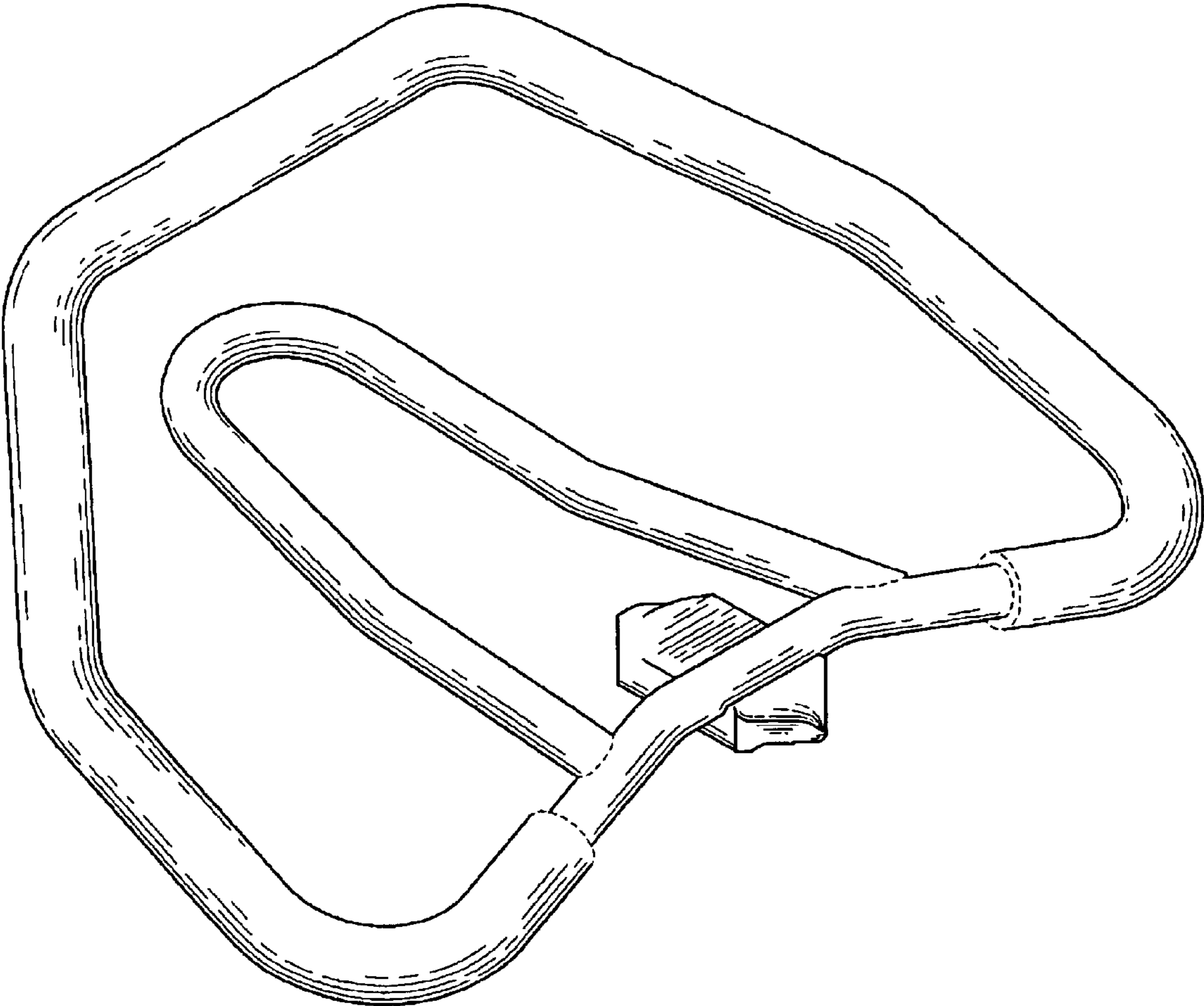

Fig. 1

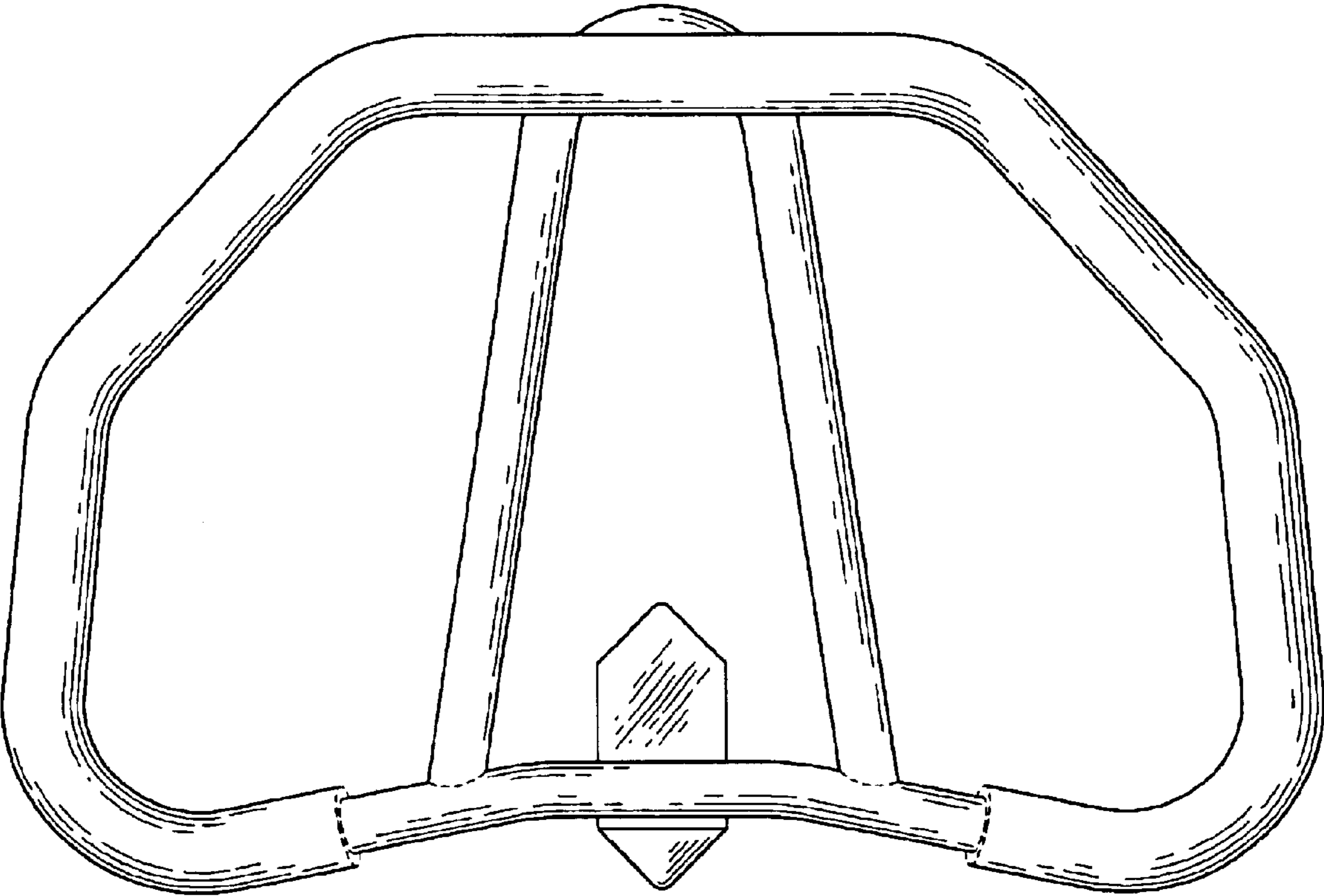

Fig. 2

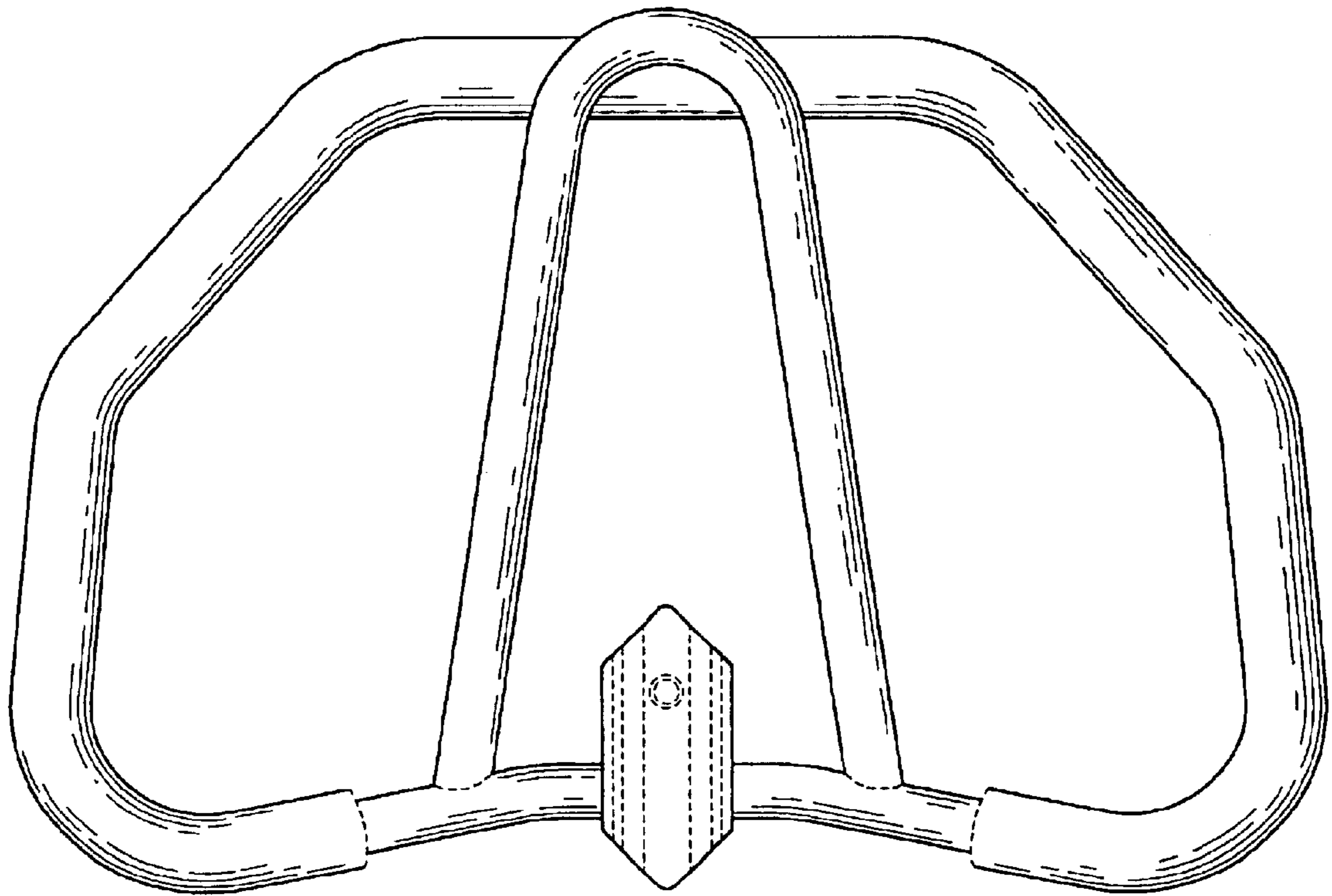

Fig. 3

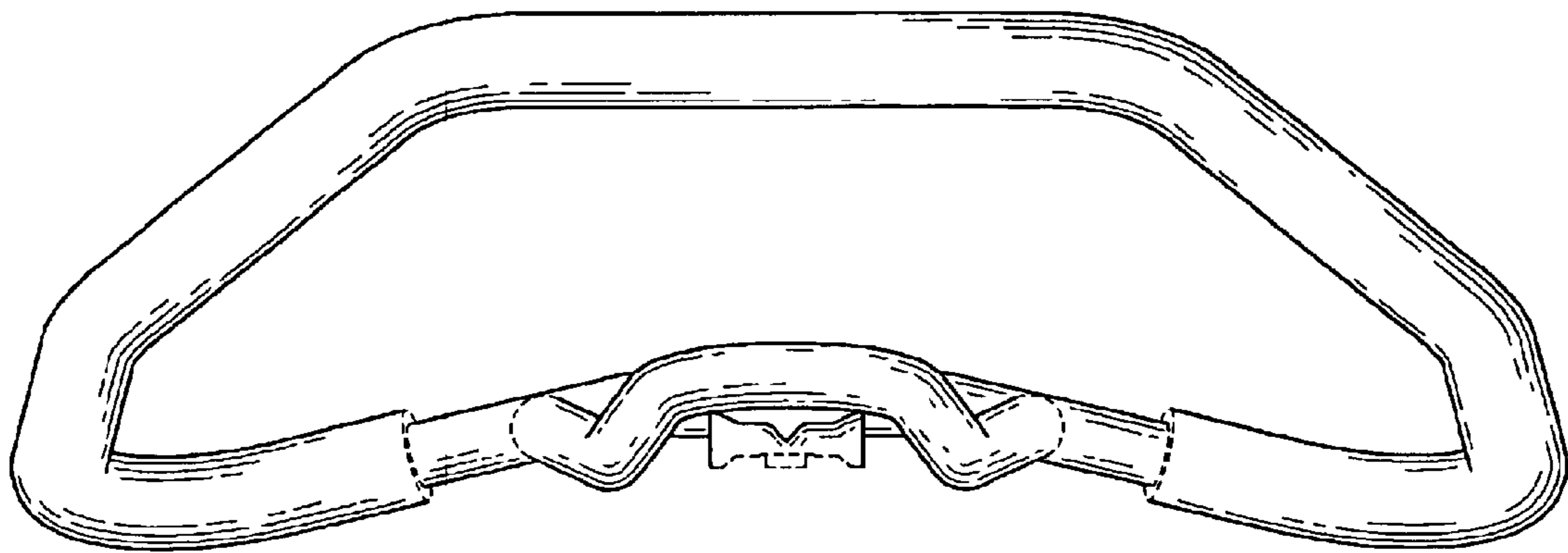

Fig. 4

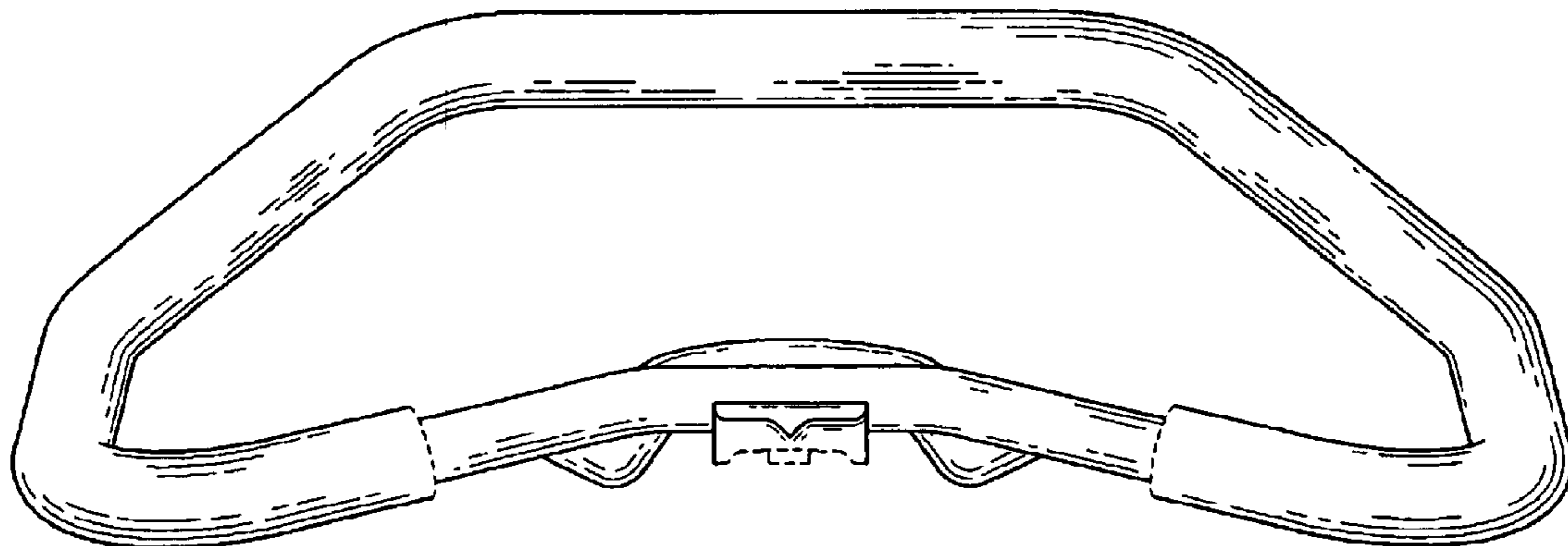

Fig. 5

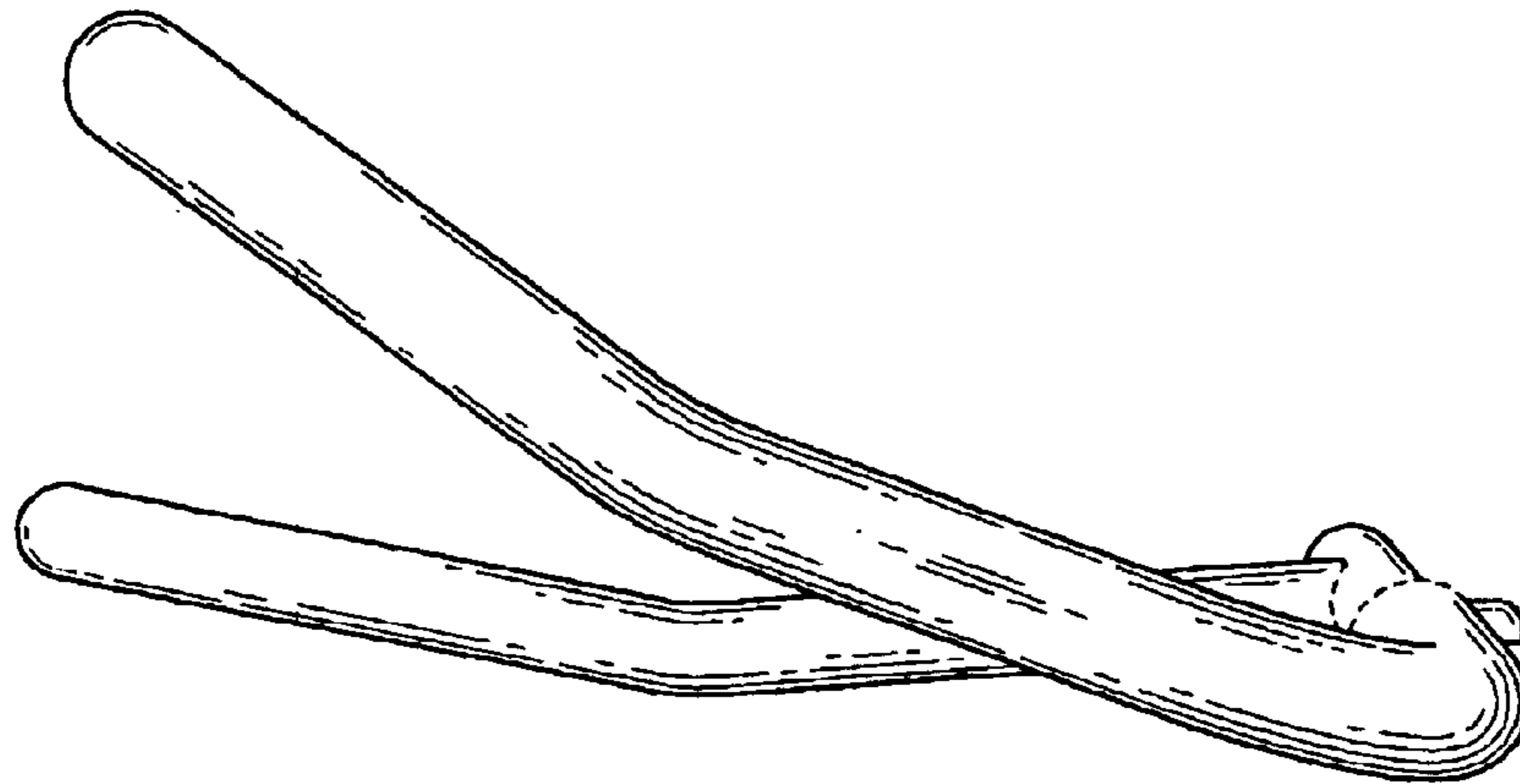

Fig. 6

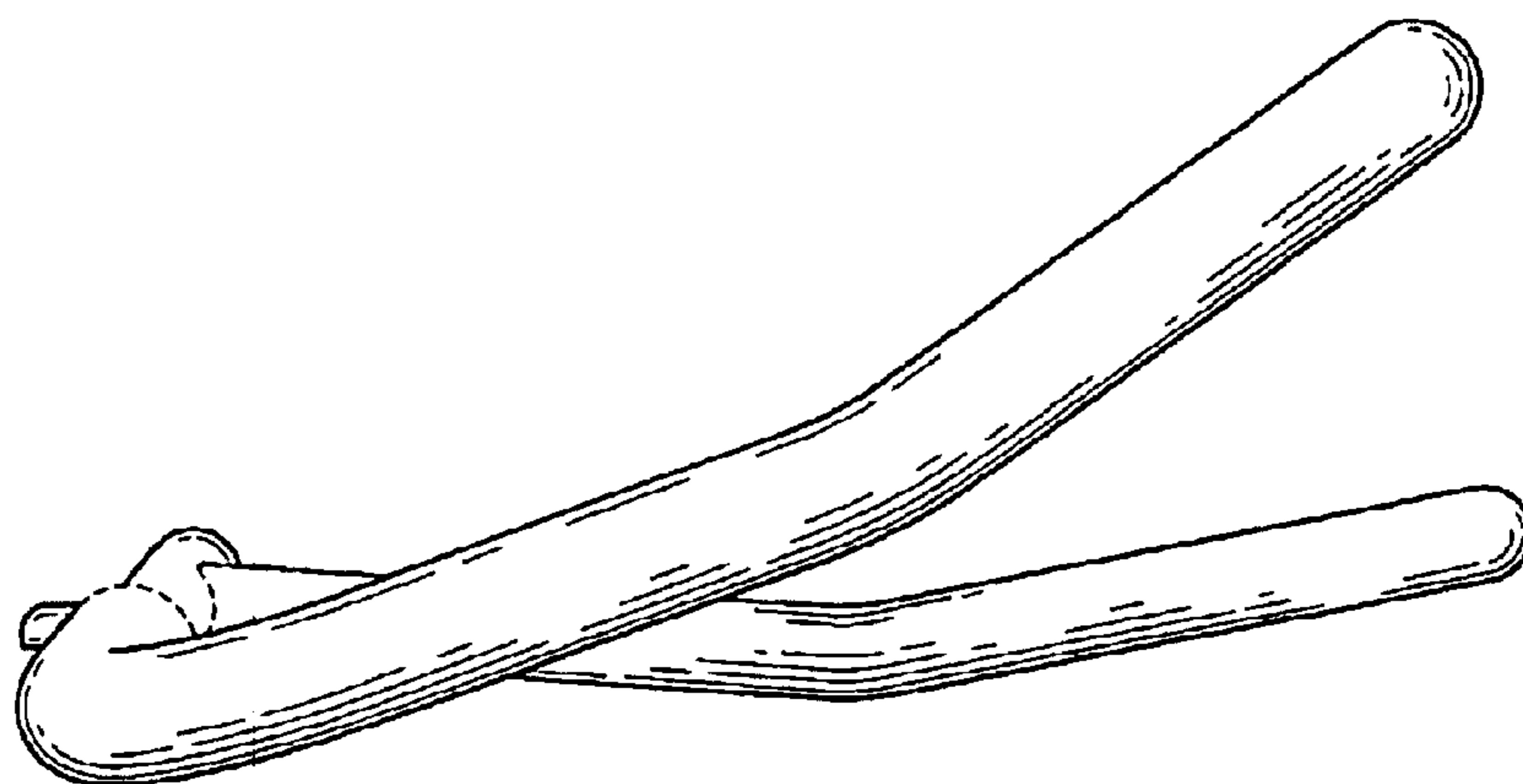

Fig. 7

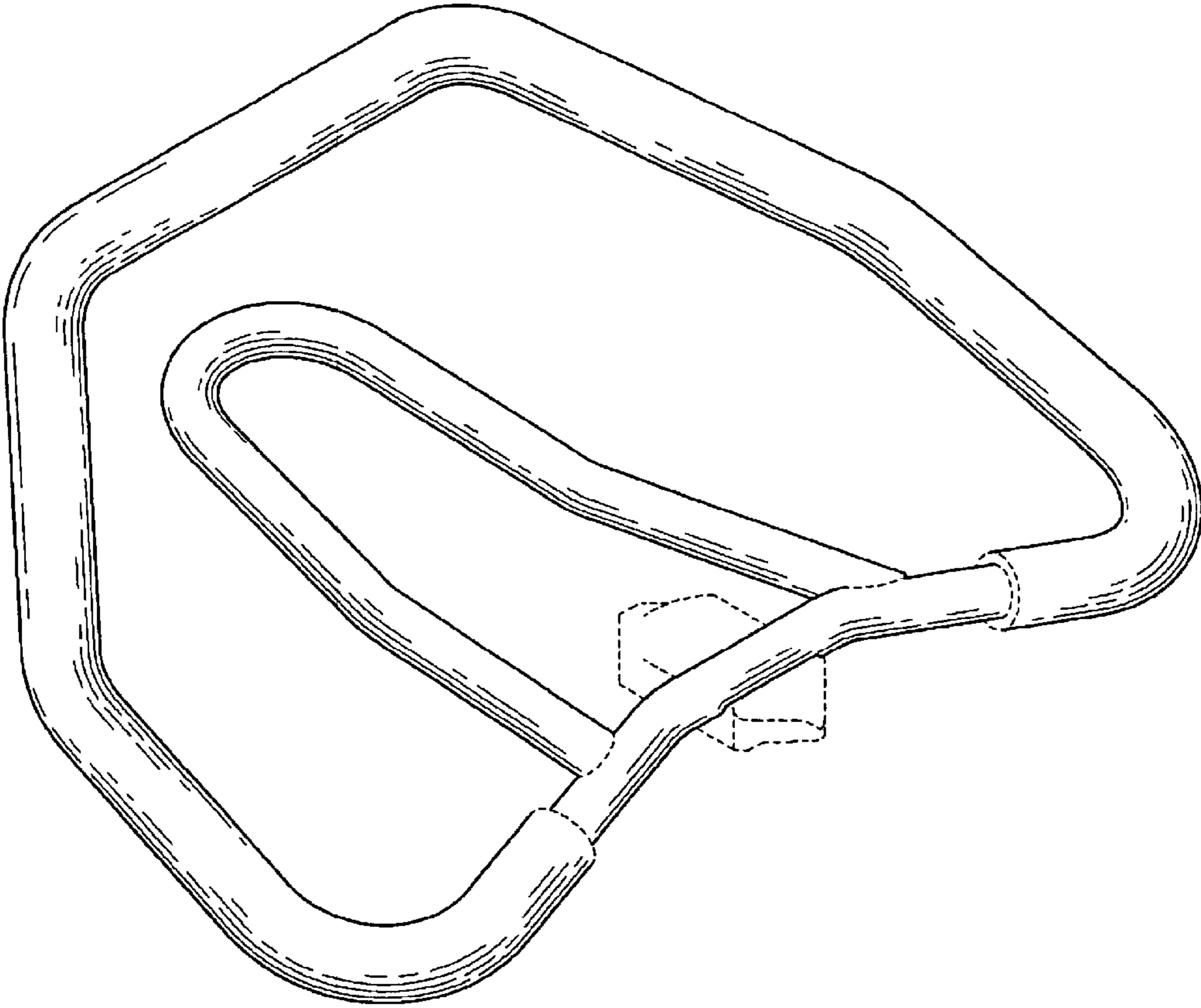

Fig. 8

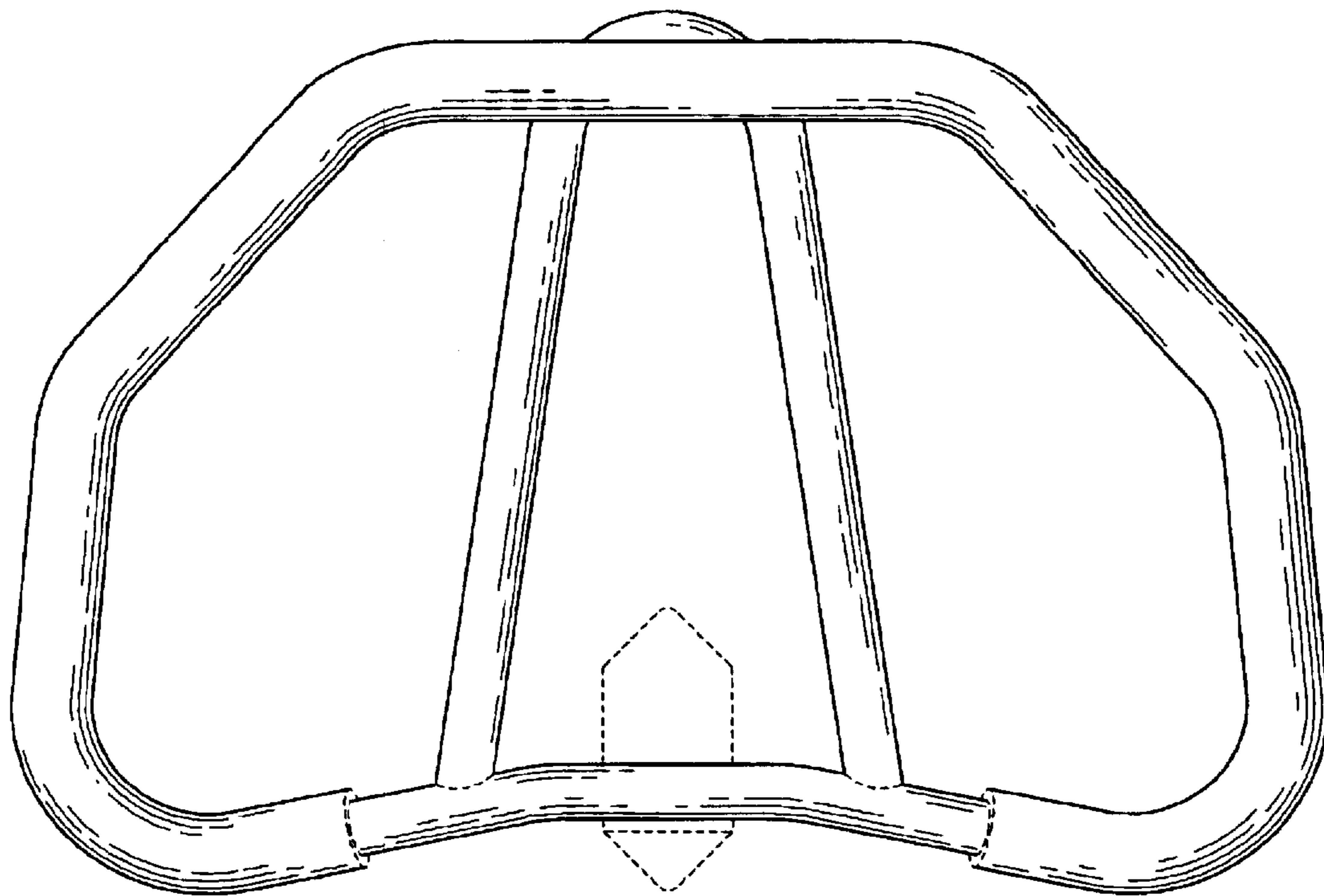

Fig. 9

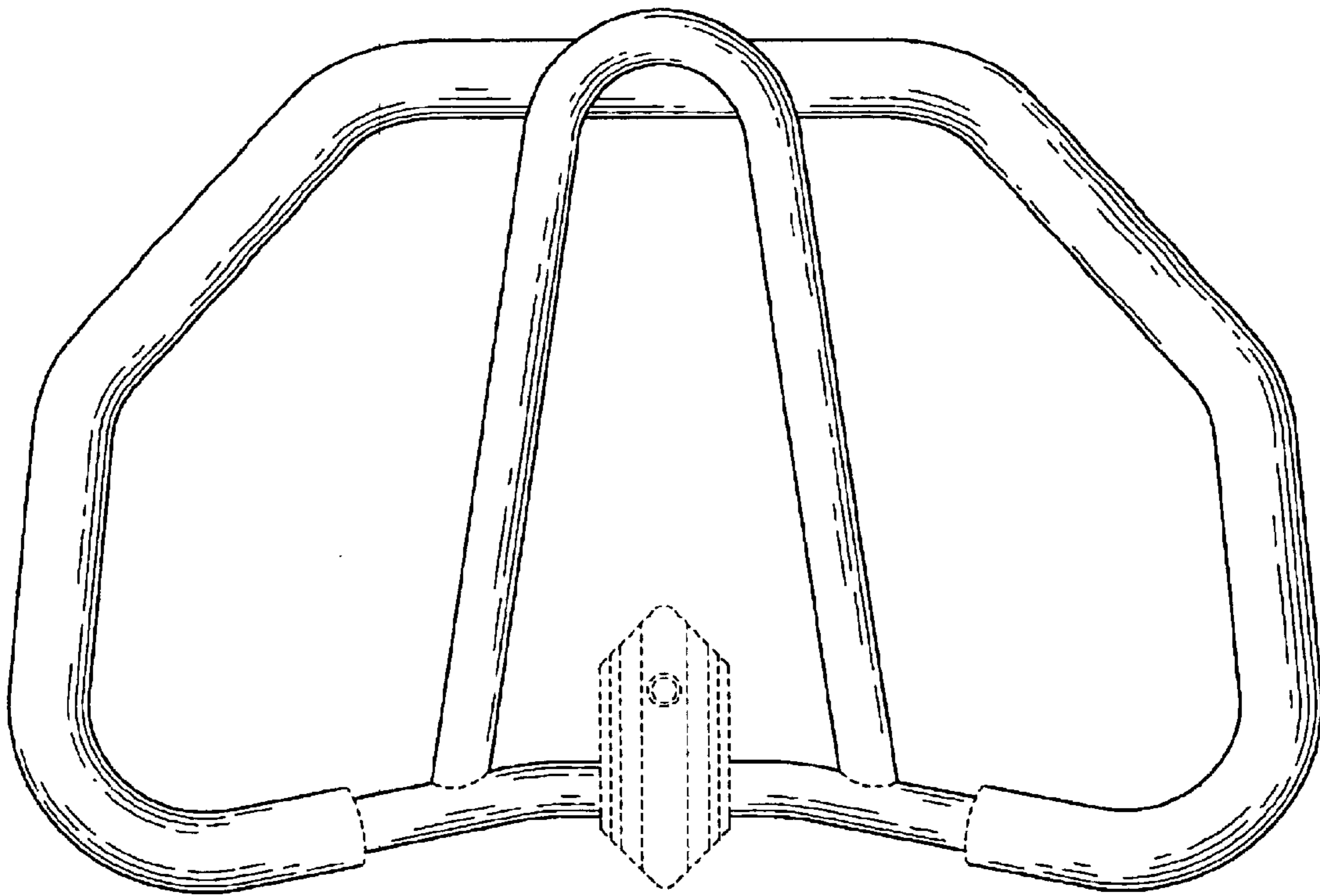

Fig. 10

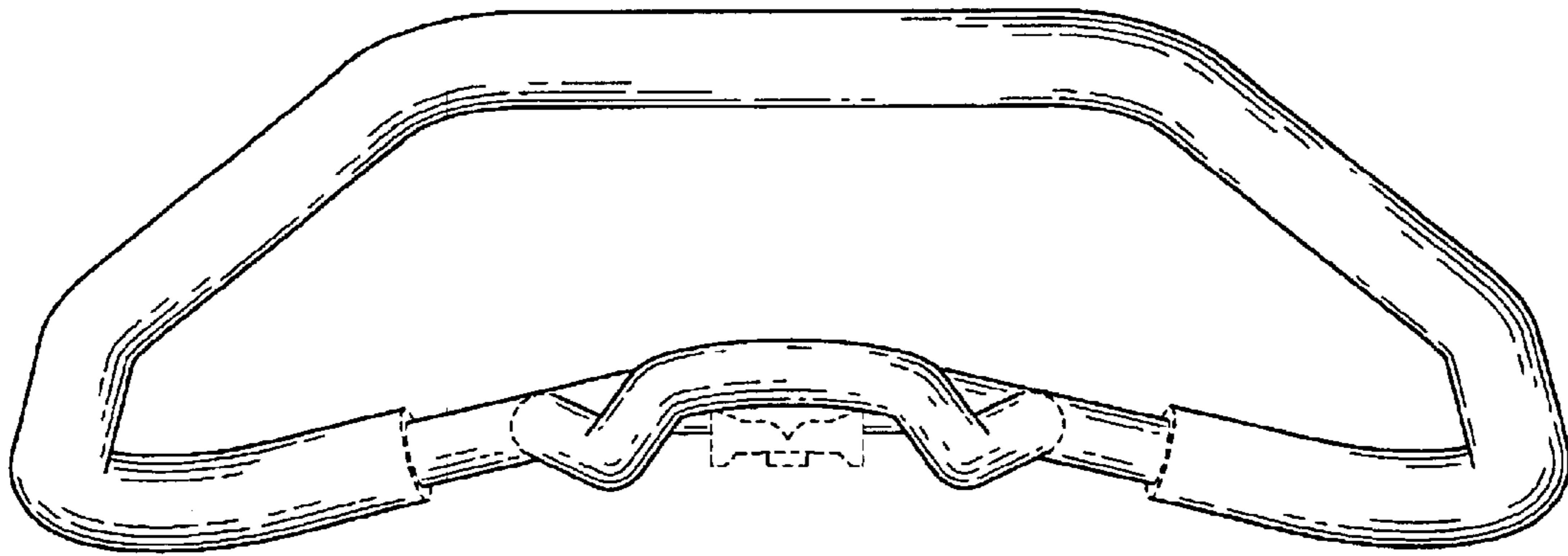

Fig. 11

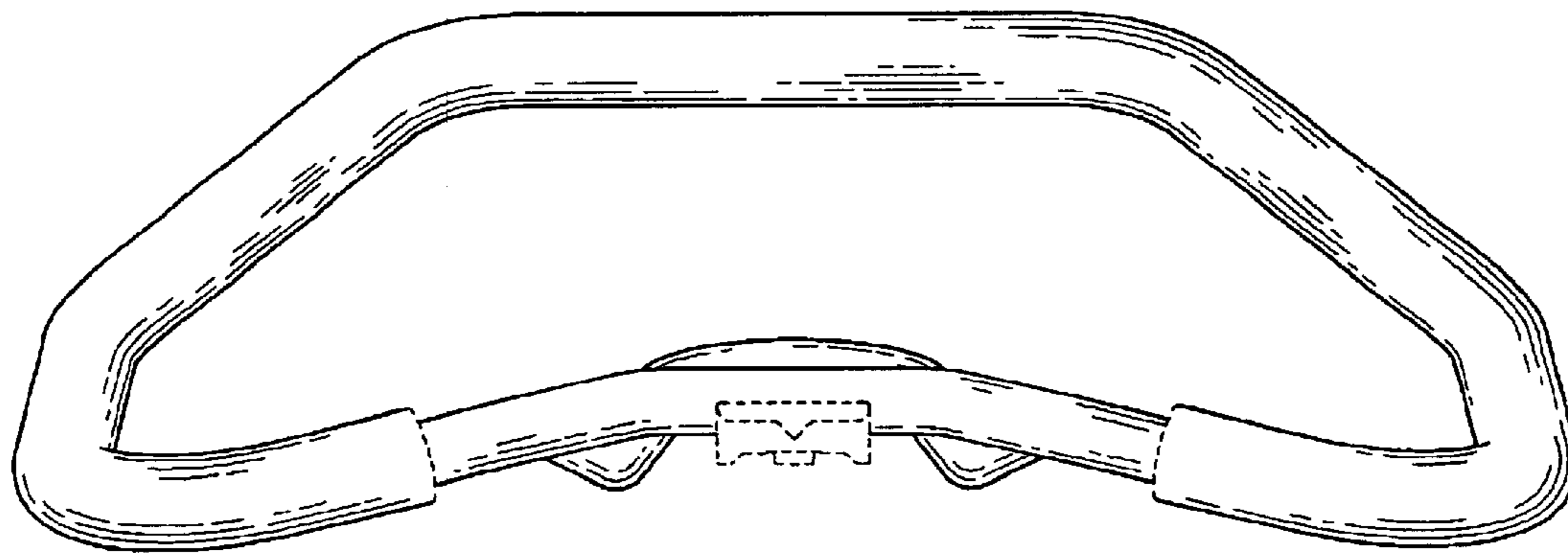

Fig. 12

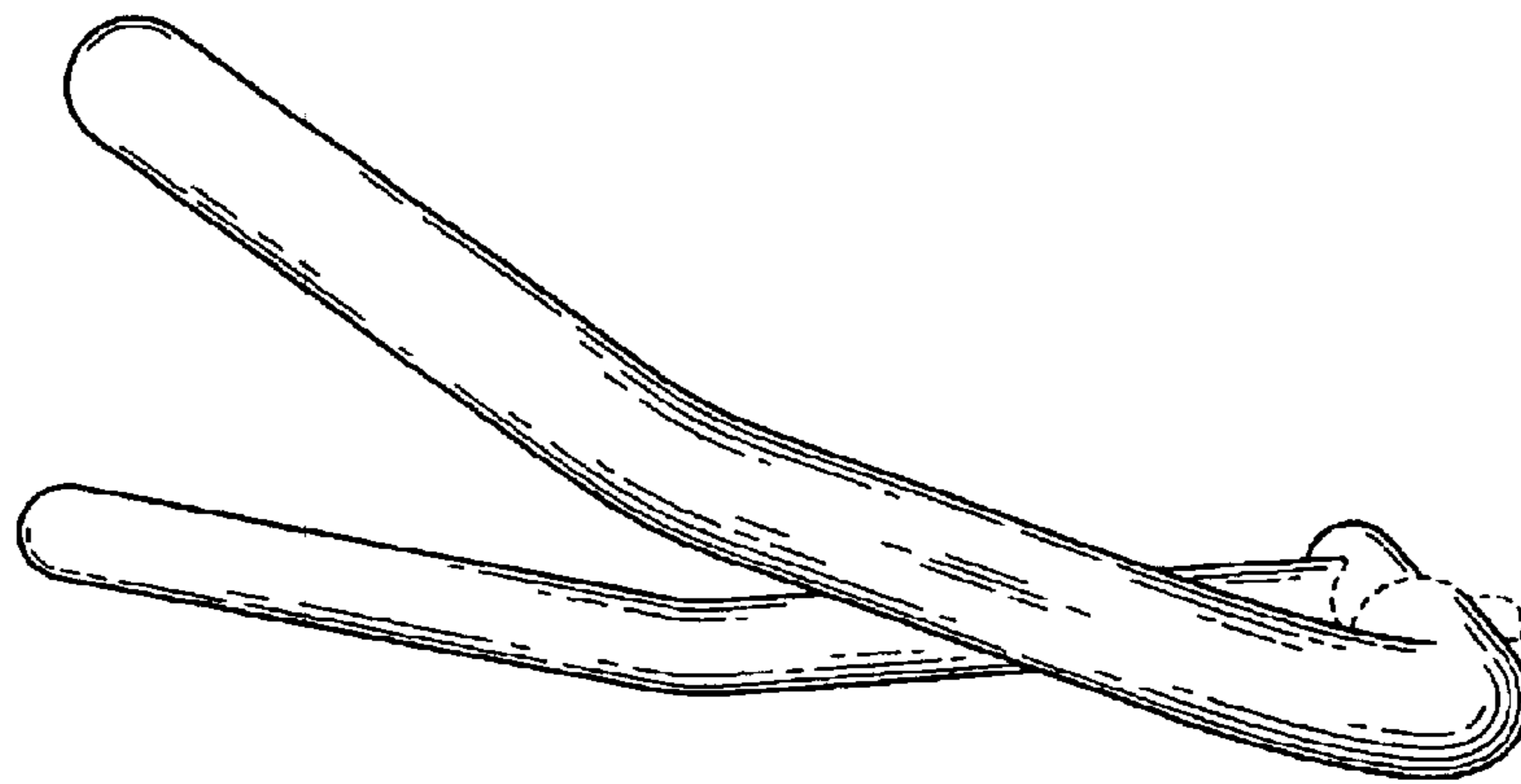

Fig. 13

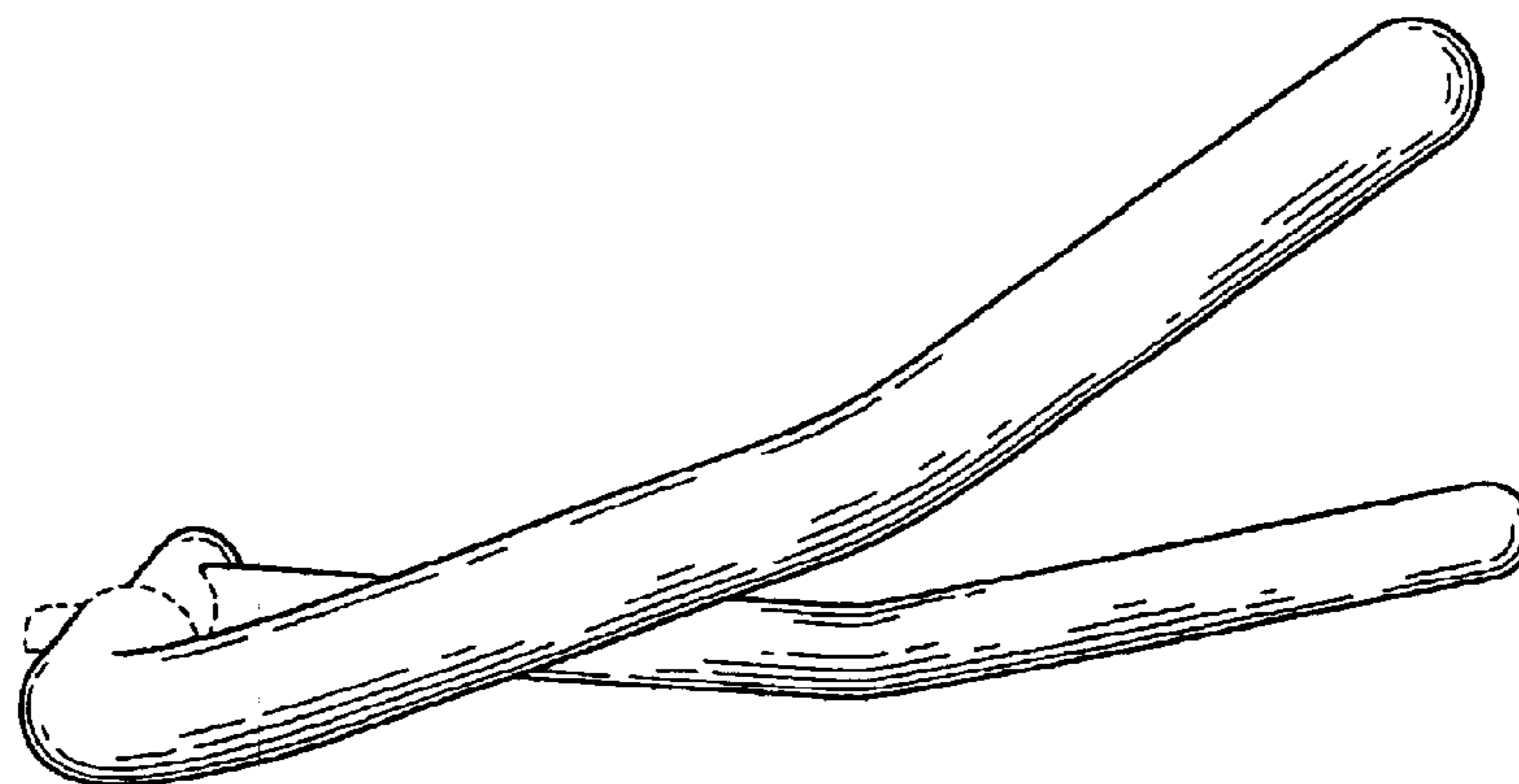

Fig. 14

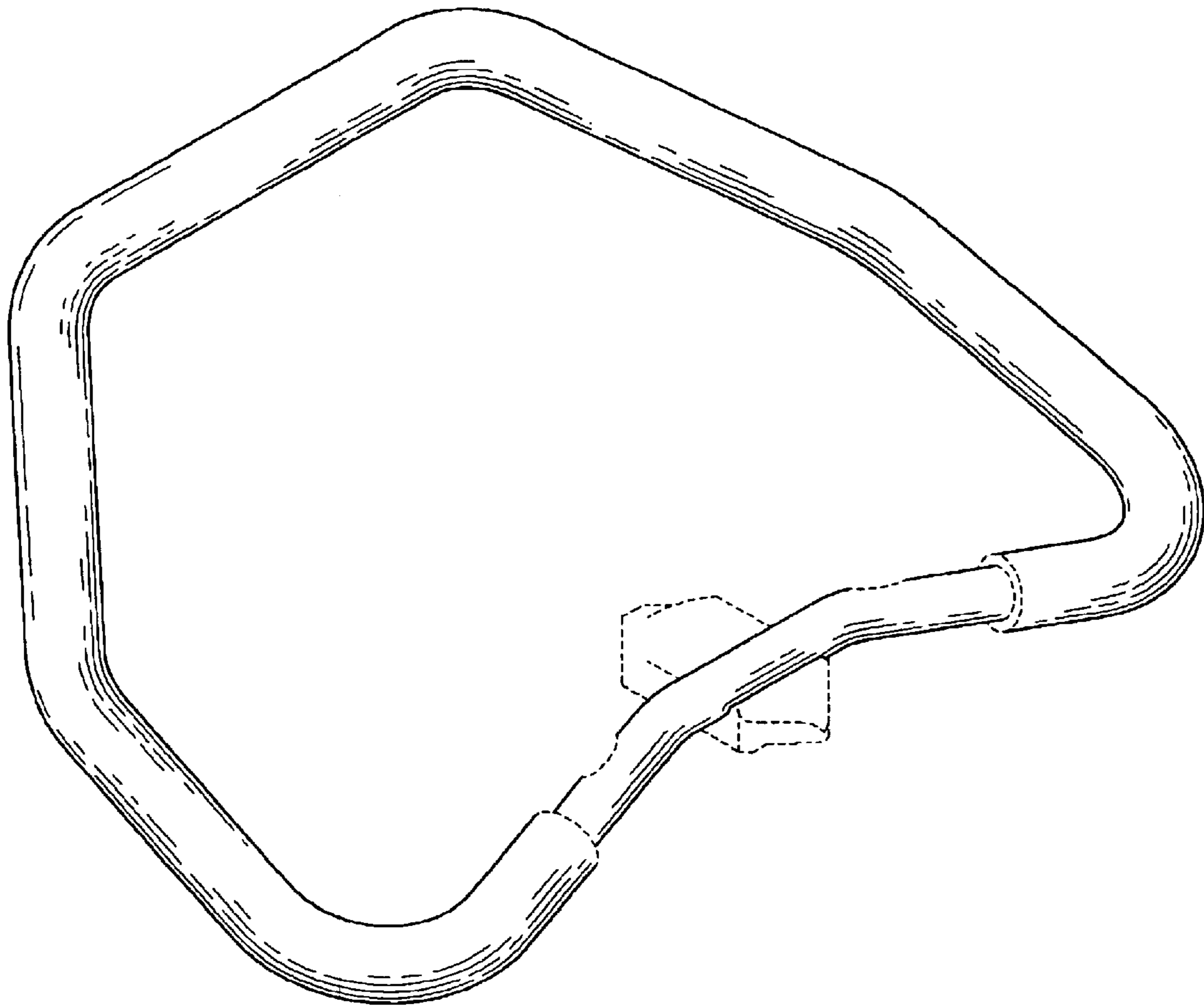

Fig. 15

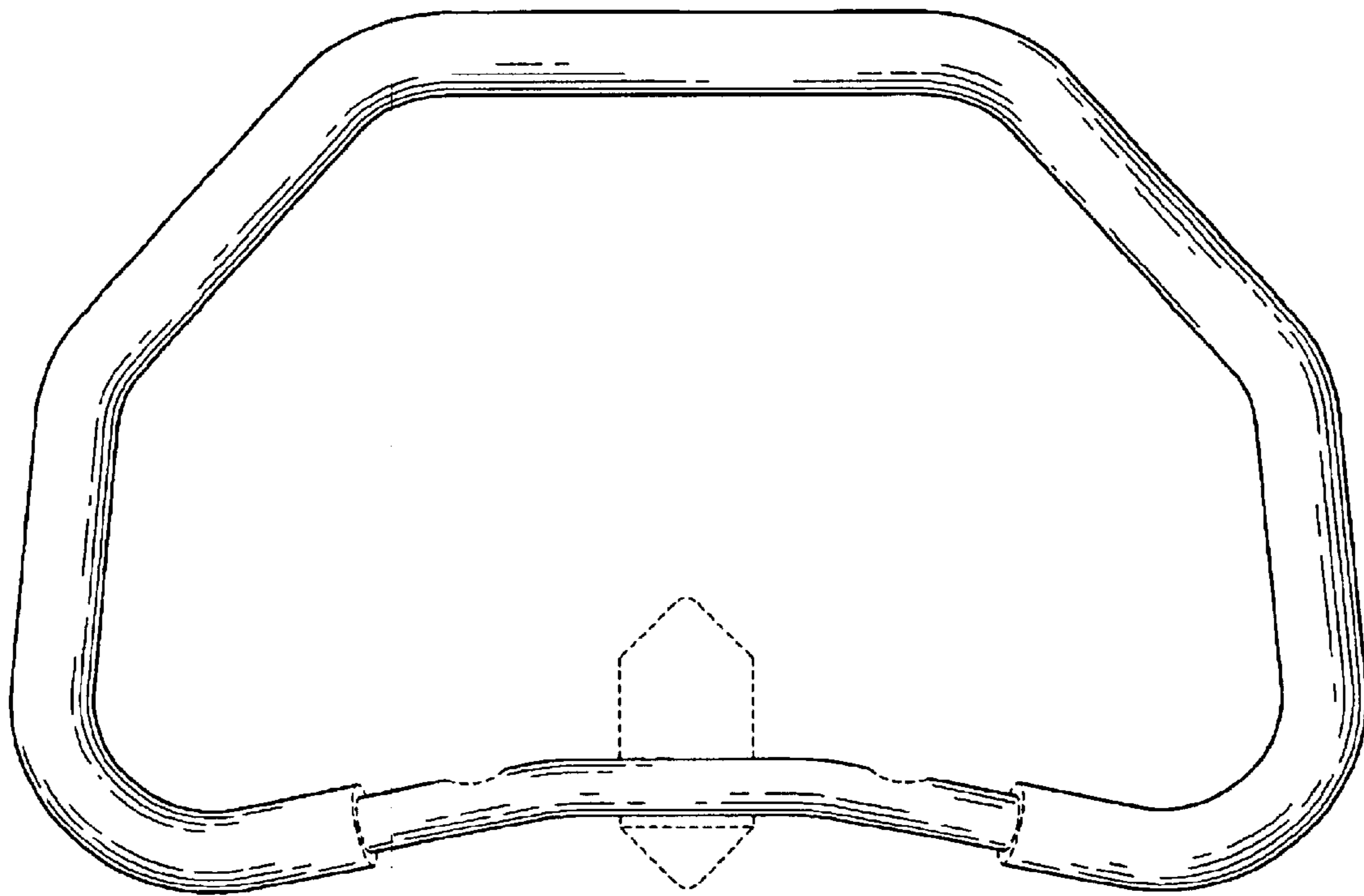

Fig. 16

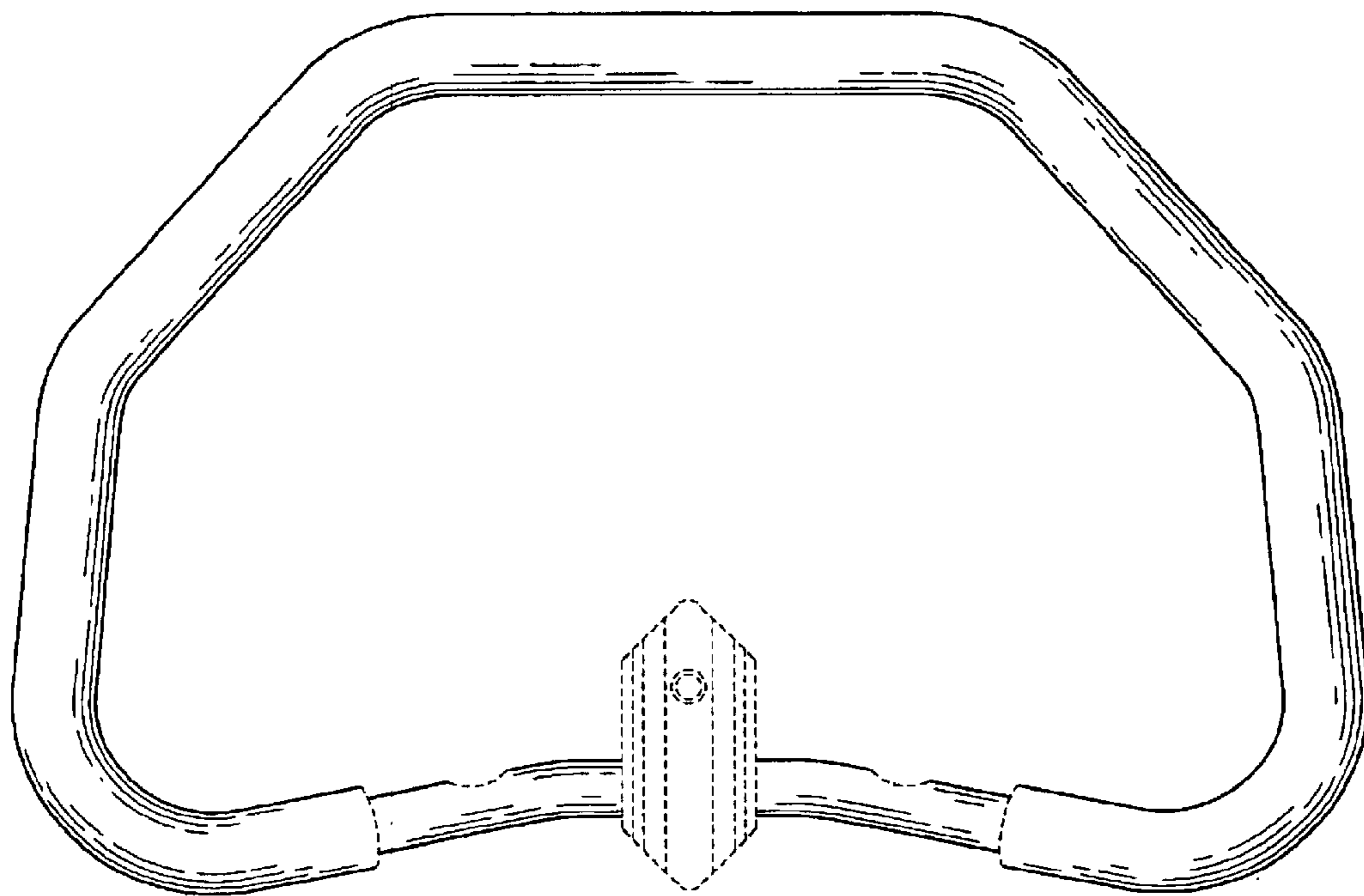

Fig. 17

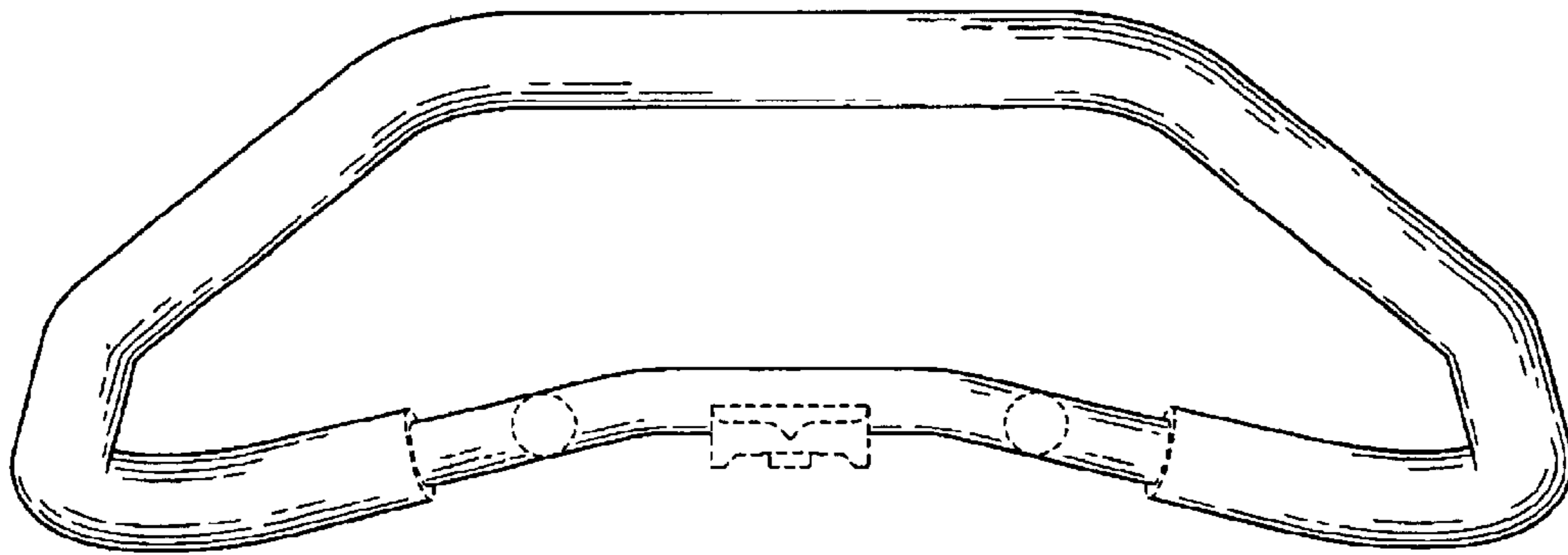

Fig. 18

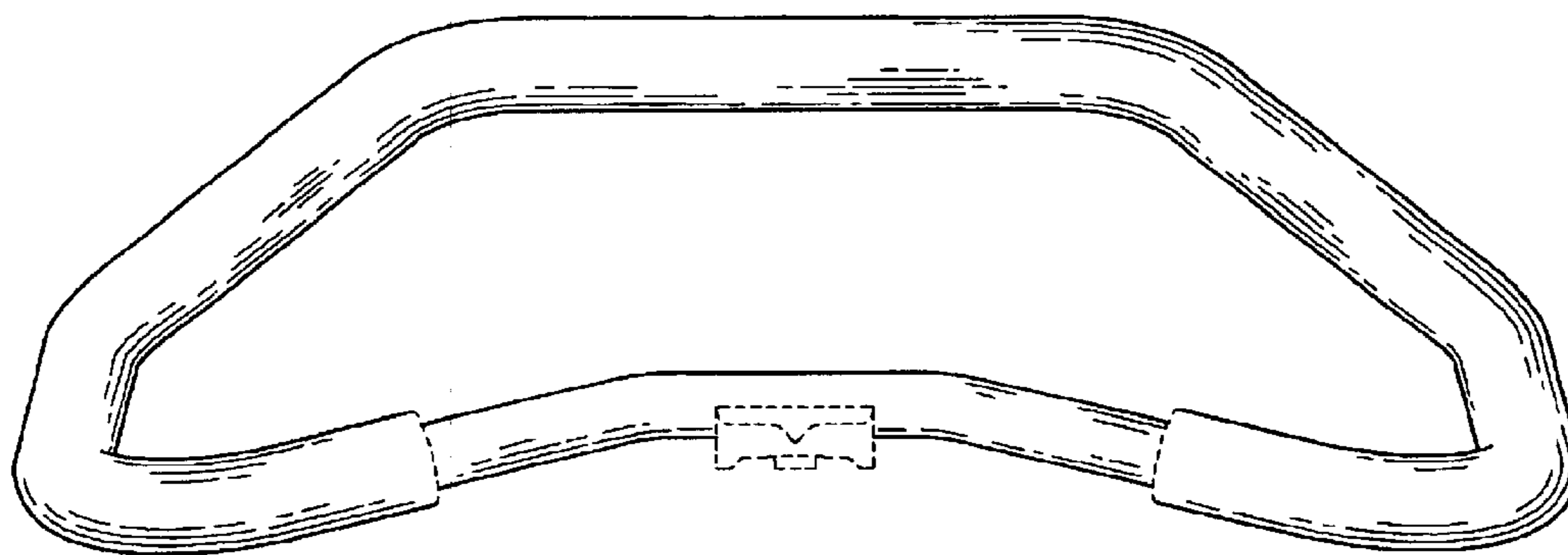

Fig. 19

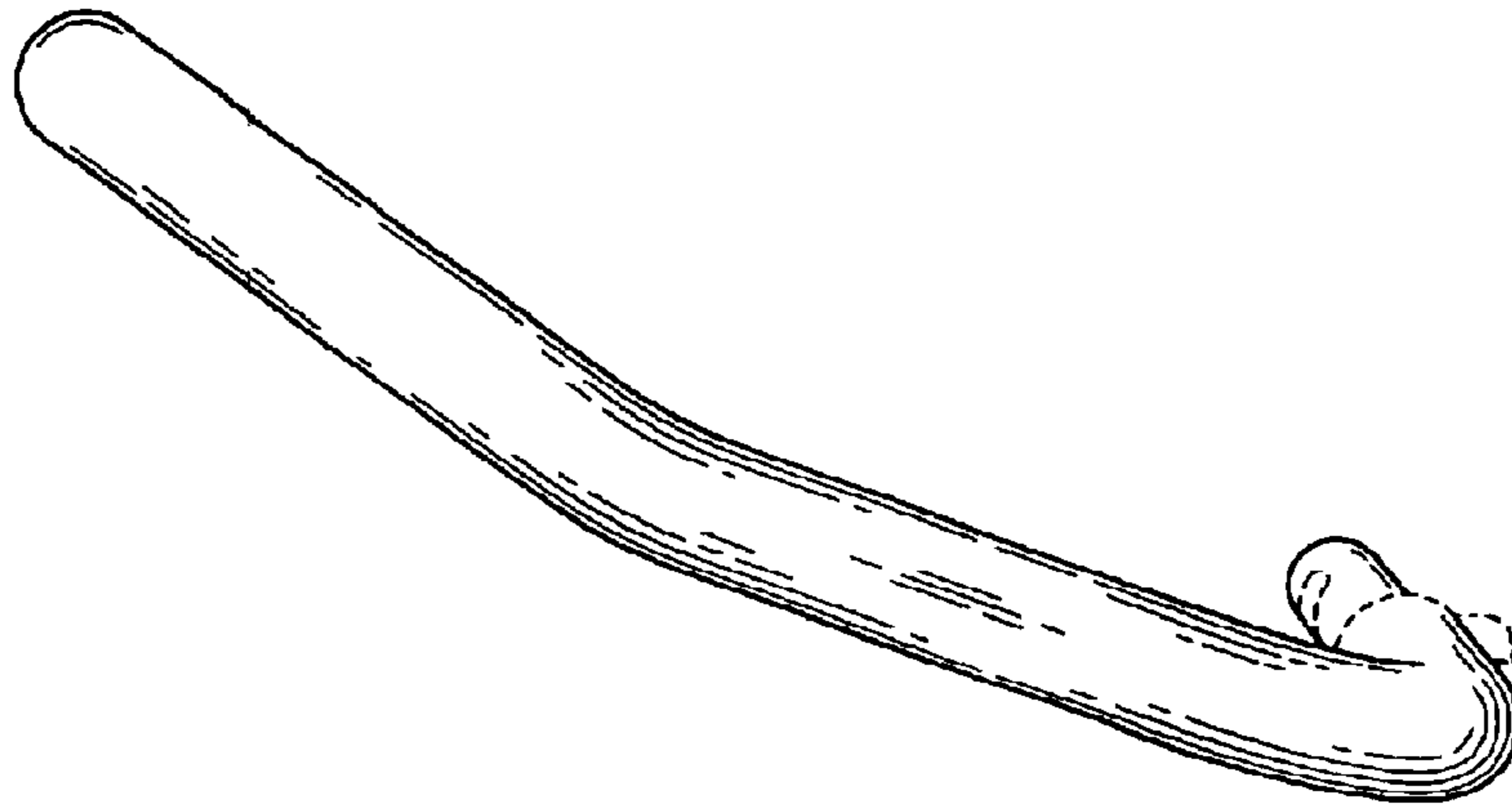

Fig. 20

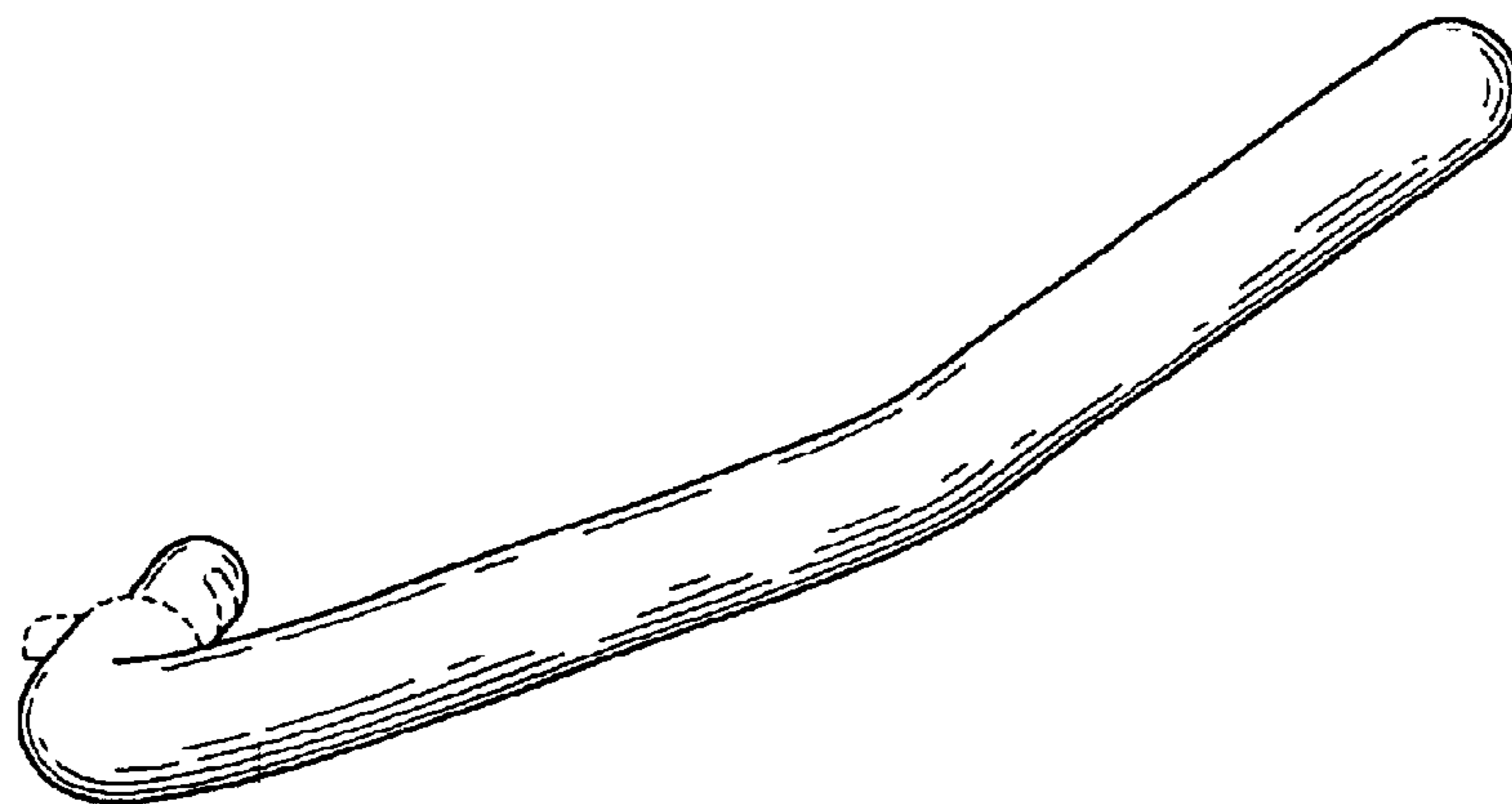

Fig. 21

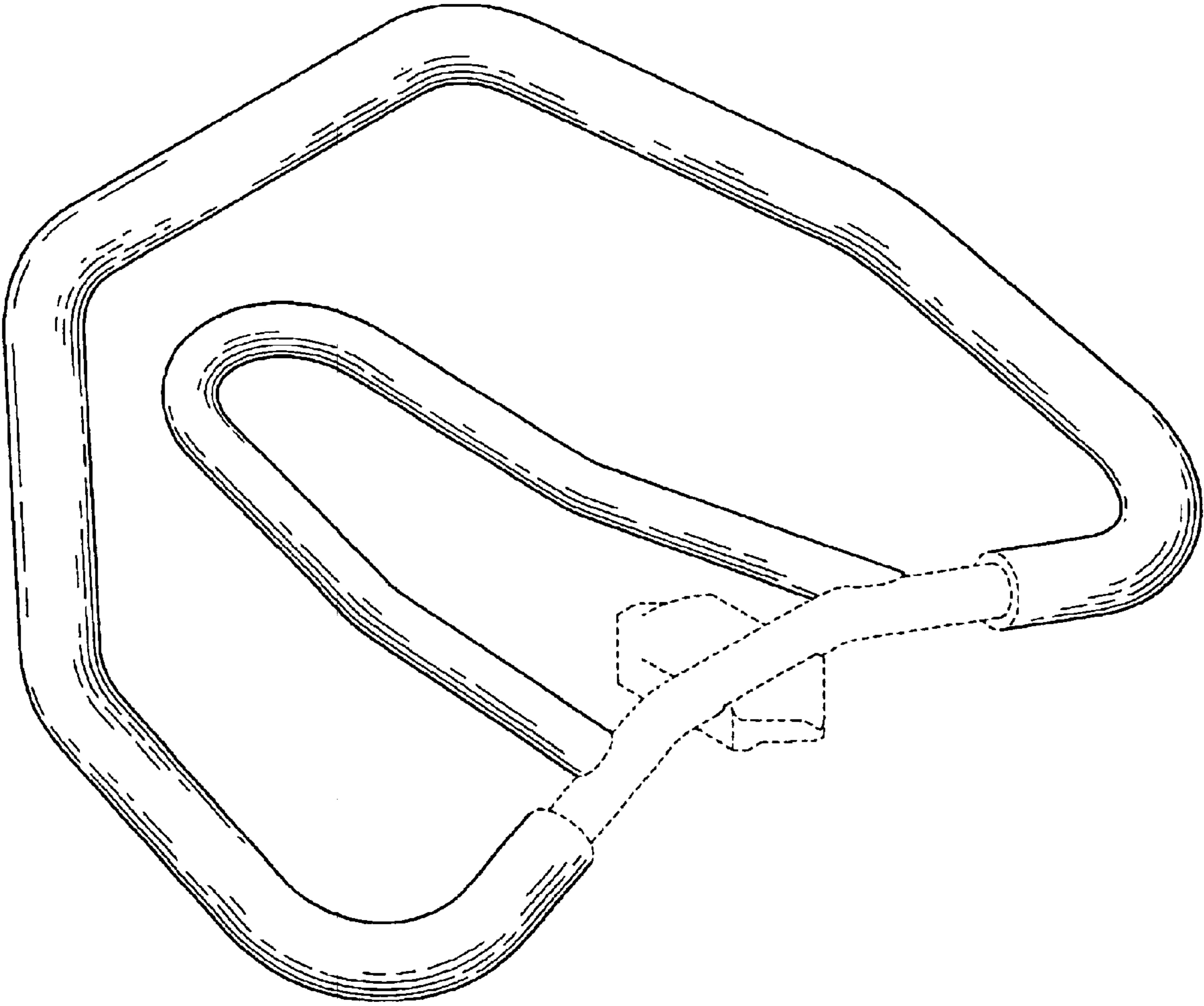

Fig. 22

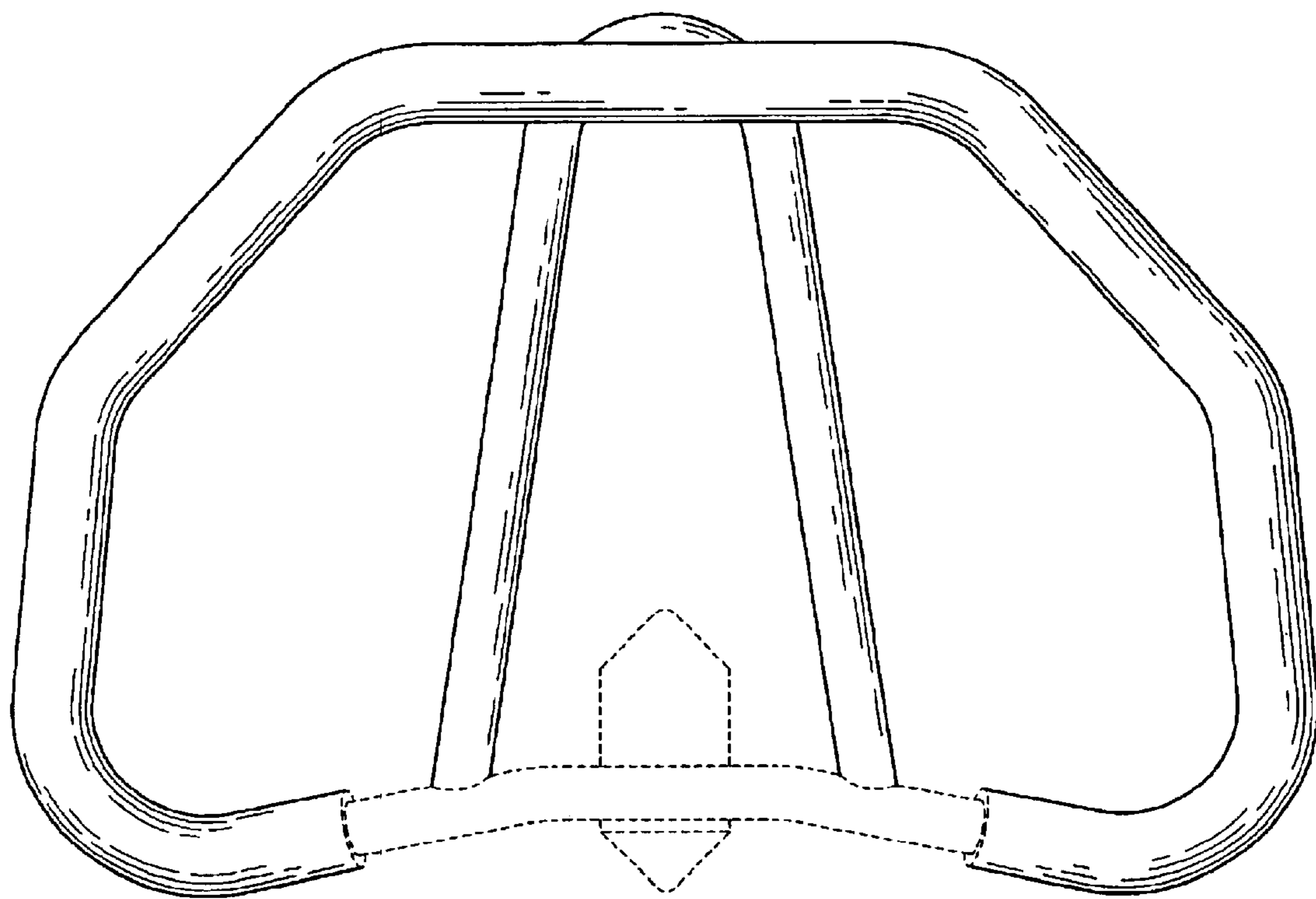

Fig. 23

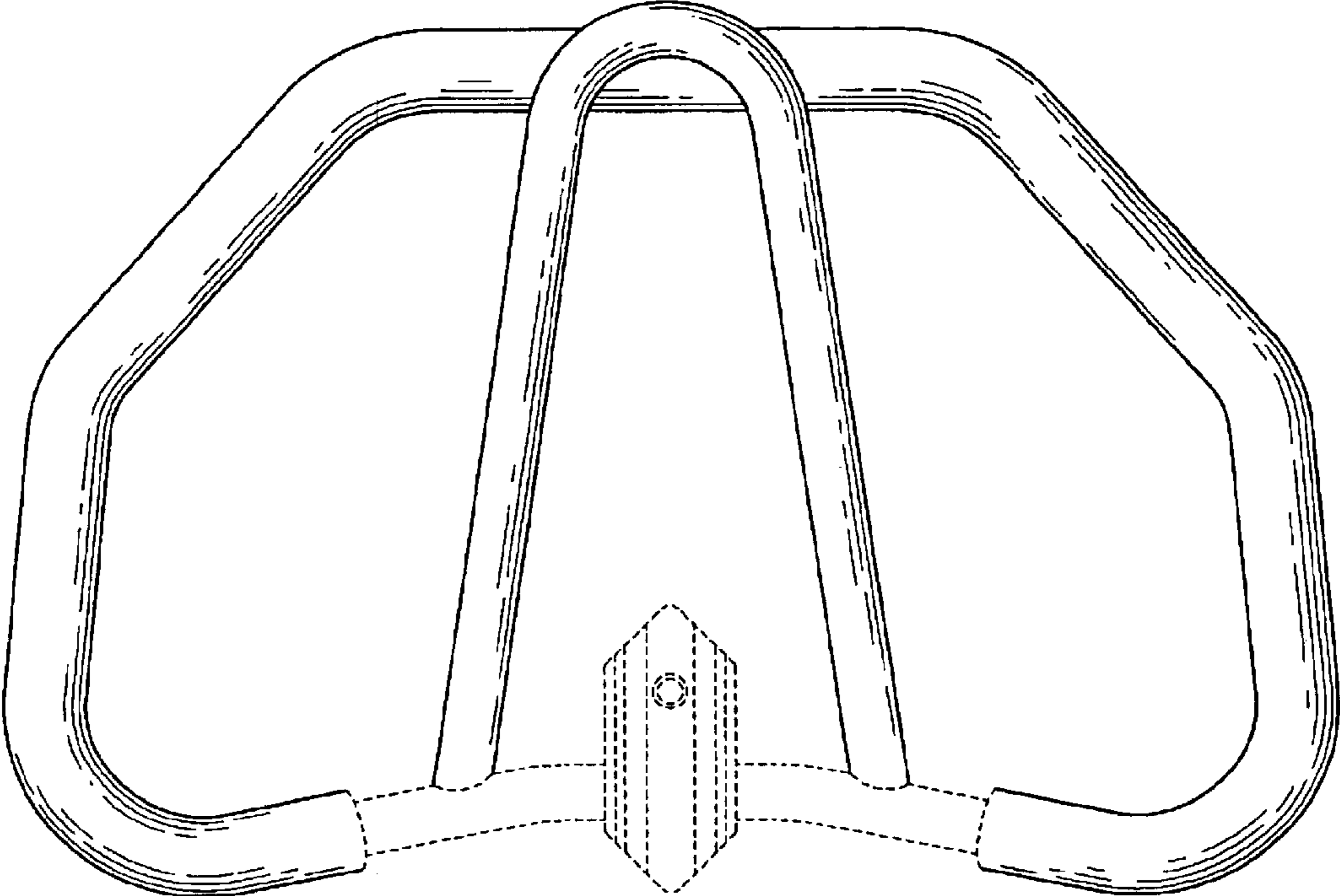

Fig. 24

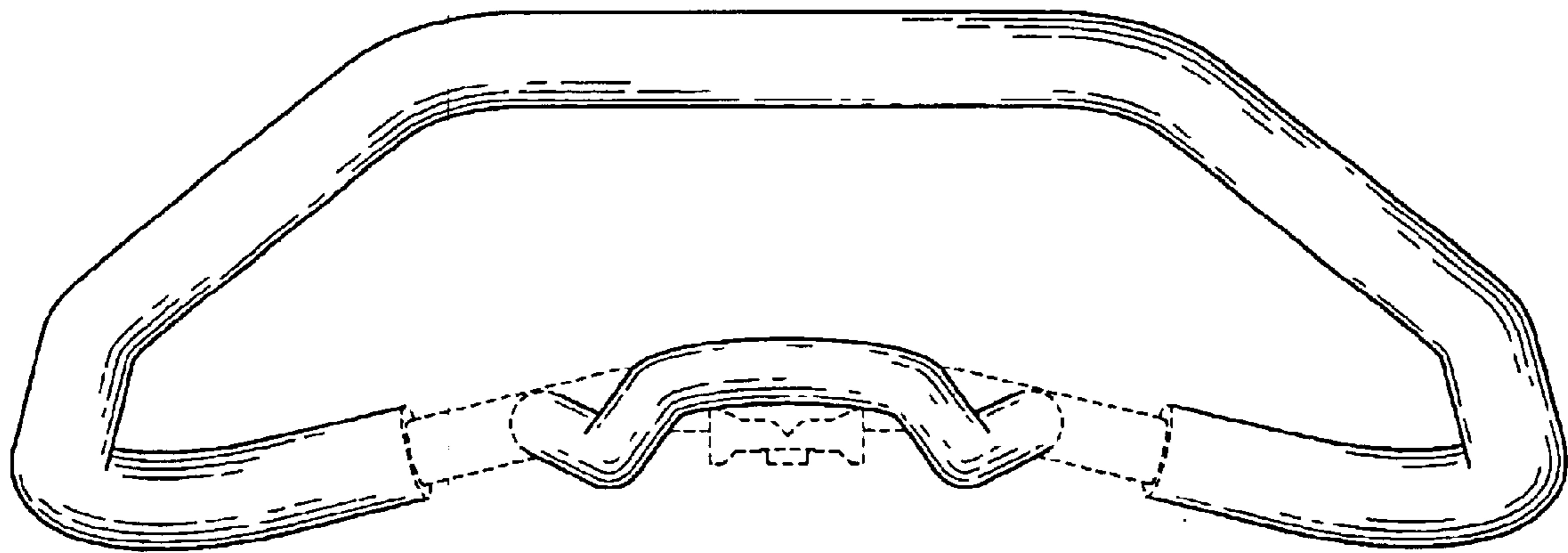

Fig. 25

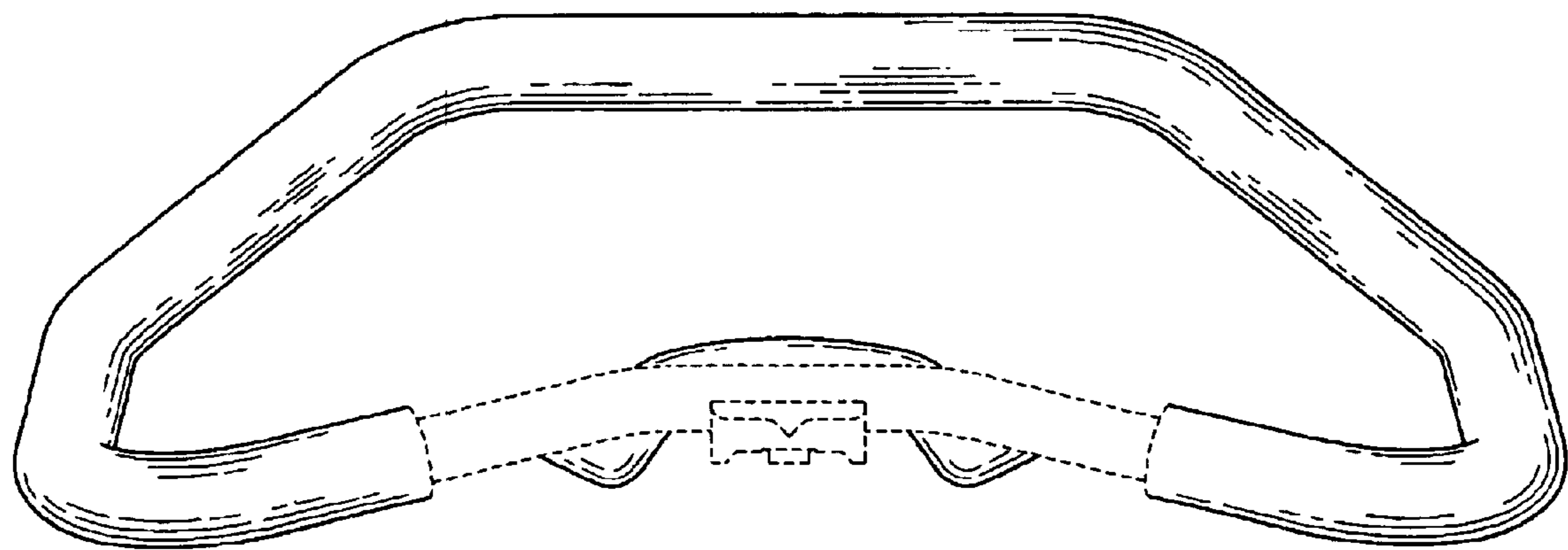

Fig. 26

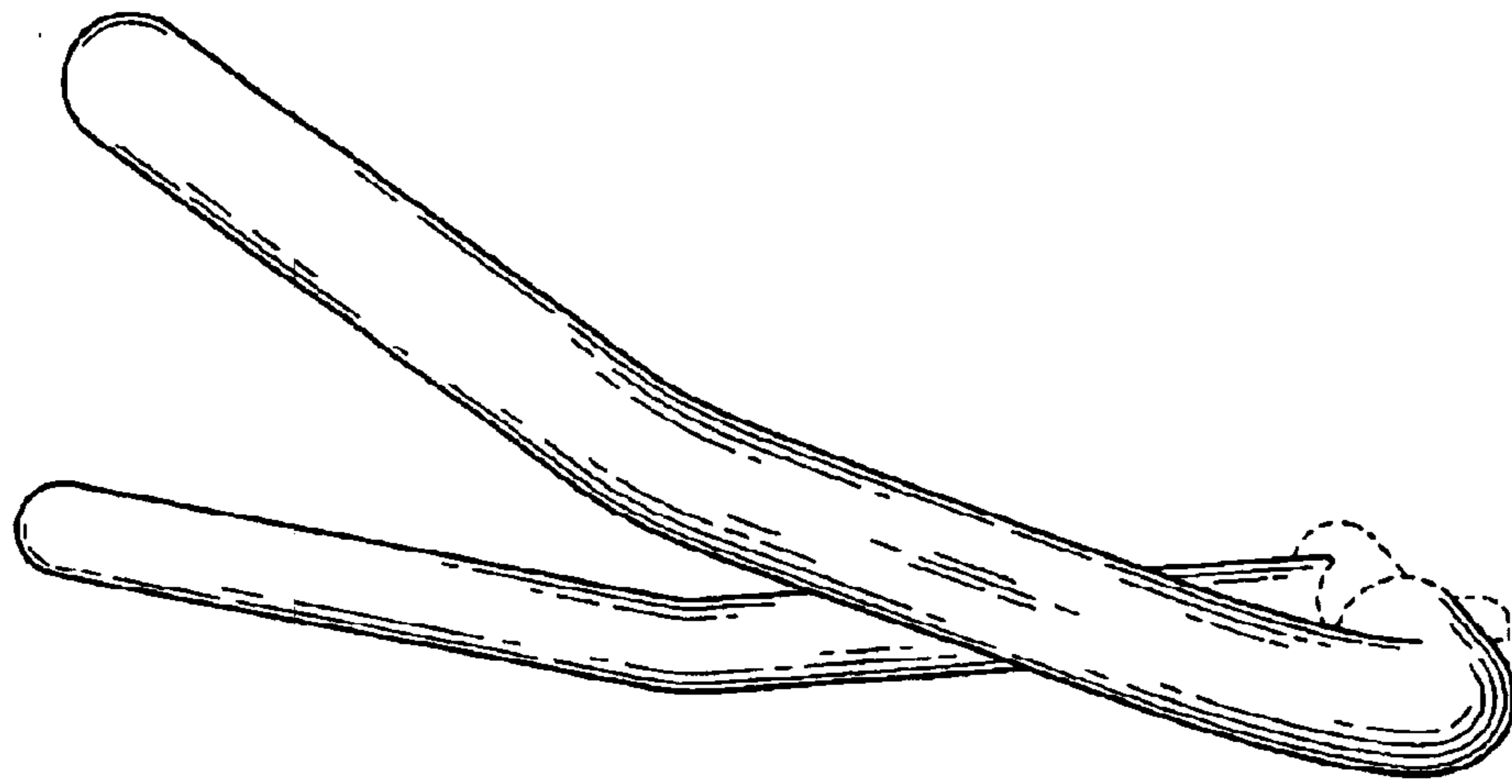

Fig. 27

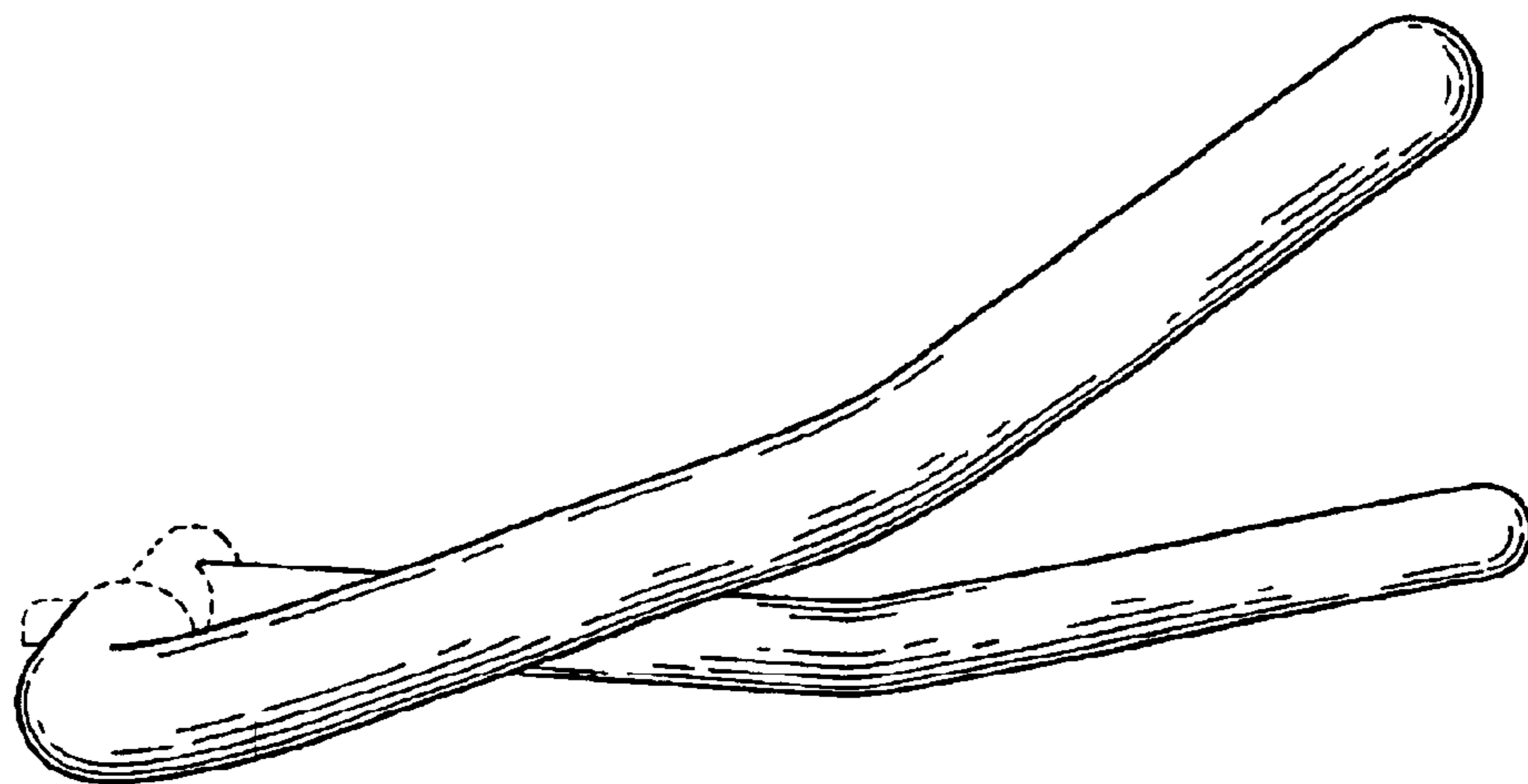

Fig. 28