



US00D511718S

(12) **United States Design Patent**
Manchester et al.

(10) **Patent No.: US D511,718 S**

(45) **Date of Patent: ** Nov. 22, 2005**

(54) **MOTORCYCLE**

(75) Inventors: **Martin Gayle Manchester**, Long Beach, CA (US); **Kenji Watanabe**, Rancho Palos Verdes, CA (US); **Yoshihiro Takanashi**, Wako (JP)

(73) Assignee: **Honda Motor Co., Ltd.**, Tokyo (JP)

(**) Term: **14 Years**

(21) Appl. No.: **29/211,696**

(22) Filed: **Aug. 20, 2004**

(30) **Foreign Application Priority Data**

Mar. 29, 2004 (JP) 2004-009482

(51) **LOC (8) Cl. 12-11**

(52) **U.S. Cl. D12/110**

(58) **Field of Search D12/110; 180/219**

(56) **References Cited**

U.S. PATENT DOCUMENTS

D447,722 S 9/2001 Ito et al.

Primary Examiner—Alan P. Douglas

Assistant Examiner—Linda Brooks

(74) *Attorney, Agent, or Firm*—Birch, Stewart, Kolasch & Birch, LLP

(57) **CLAIM**

The ornamental design for a motorcycle, as shown and described.

DESCRIPTION

FIG. 1 is a right side elevation view of motorcycle, showing our new design;

FIG. 2 is a left side elevation view thereof;

FIG. 3 is a top plan view thereof;

FIG. 4 is a front elevation view thereof;

FIG. 5 is a rear elevation view thereof;

FIG. 6 is a perspective view thereof; and,

FIG. 7 is another perspective view thereof.

1 Claim, 5 Drawing Sheets

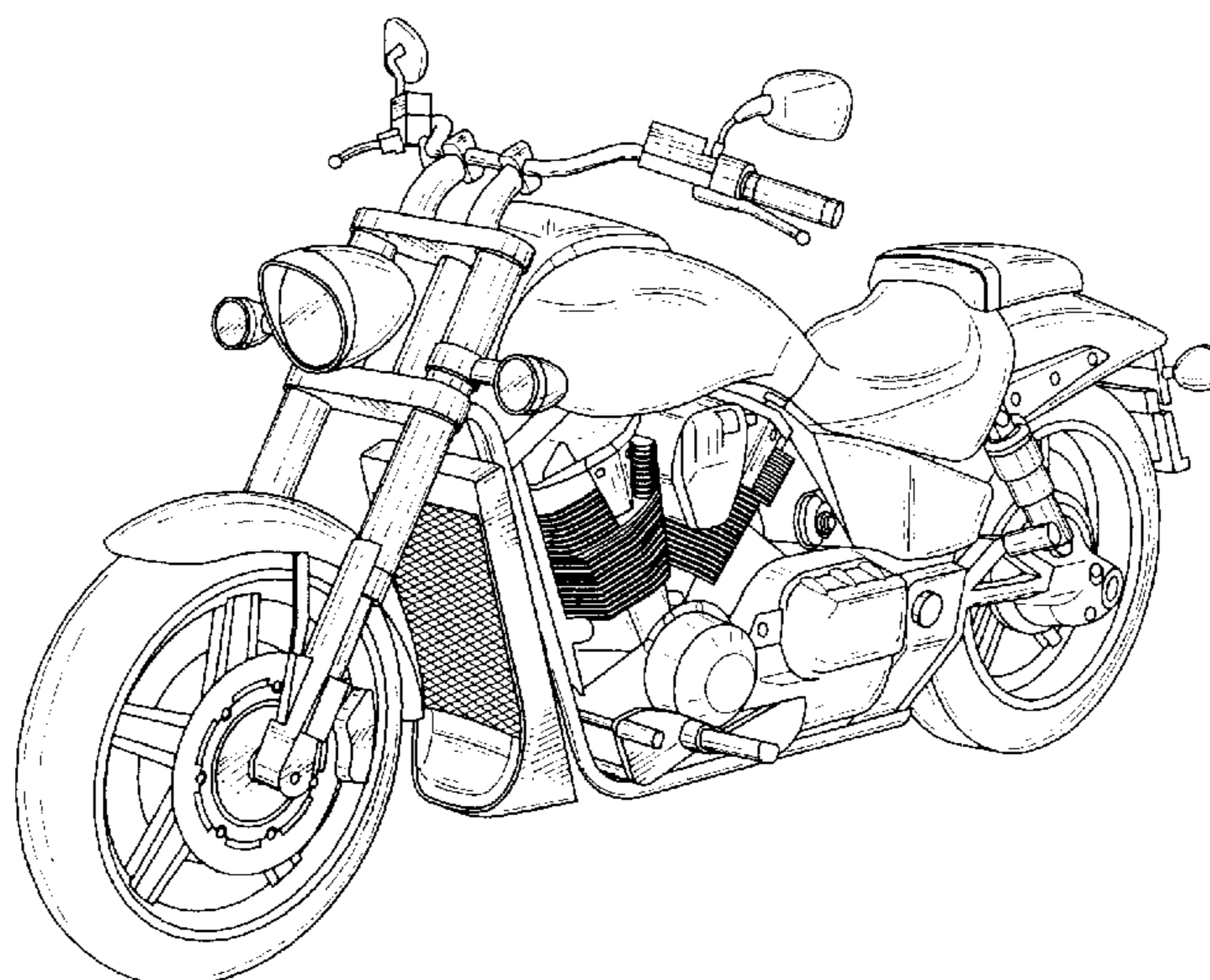
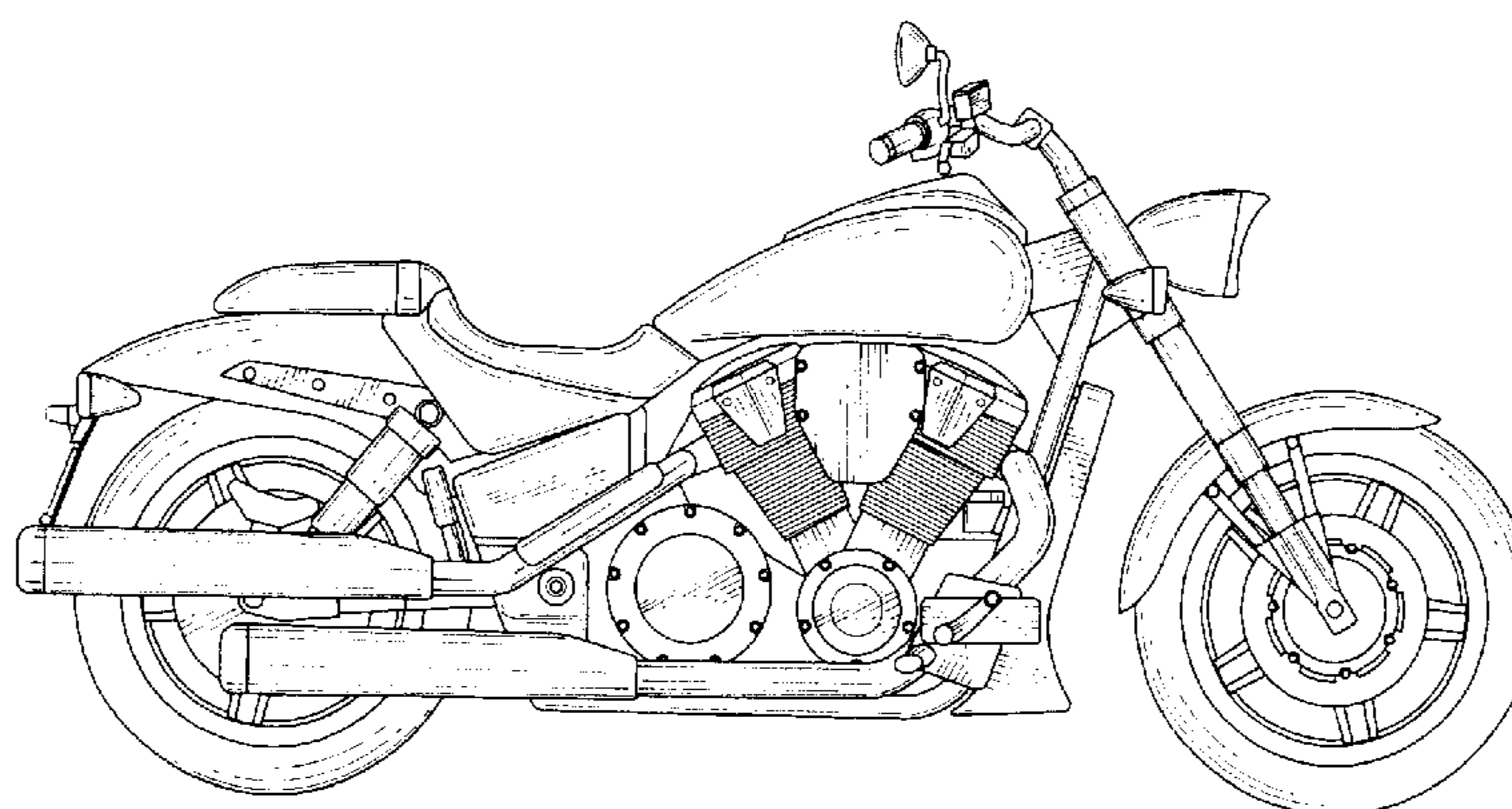

F I G. 1

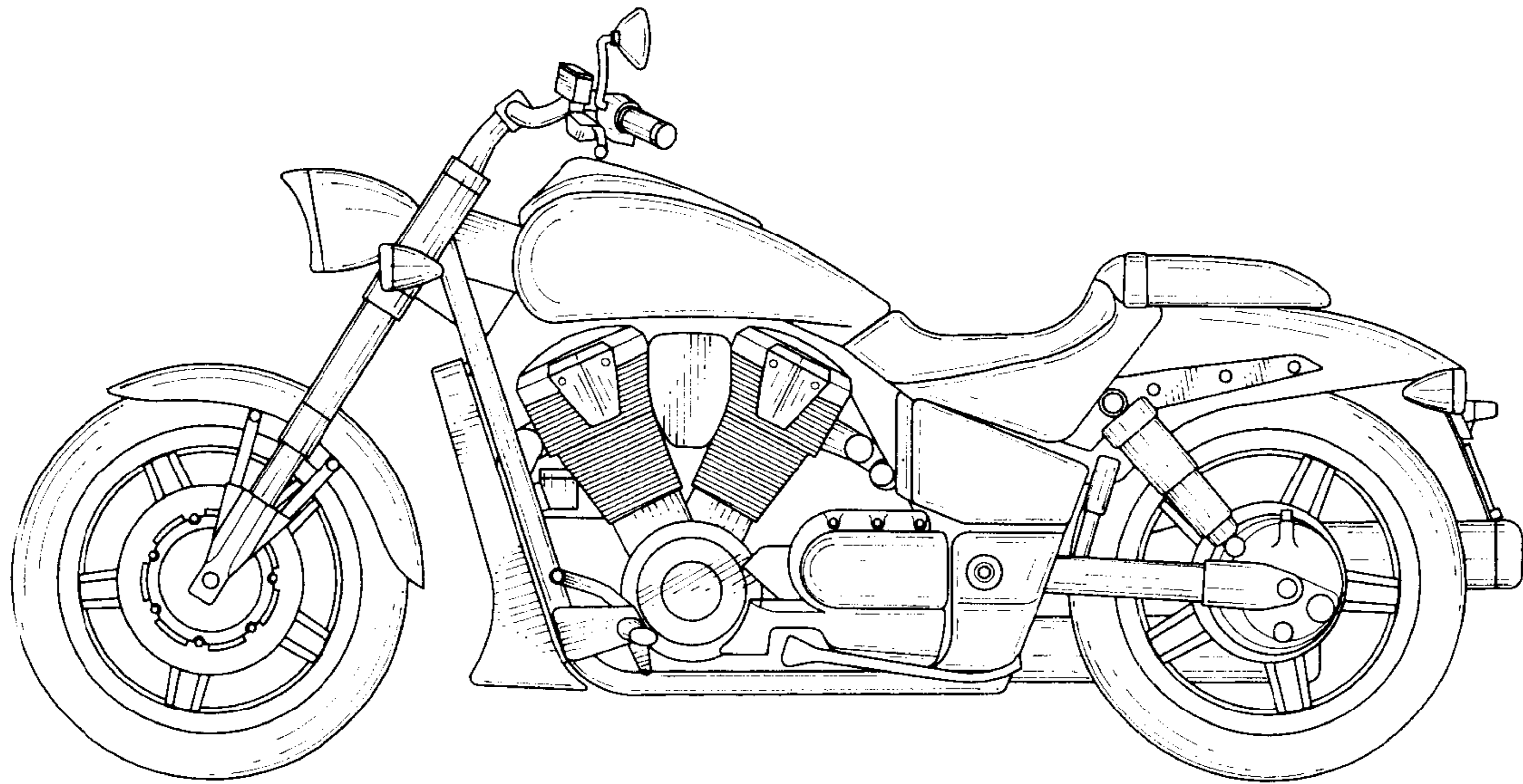

F I G. 2

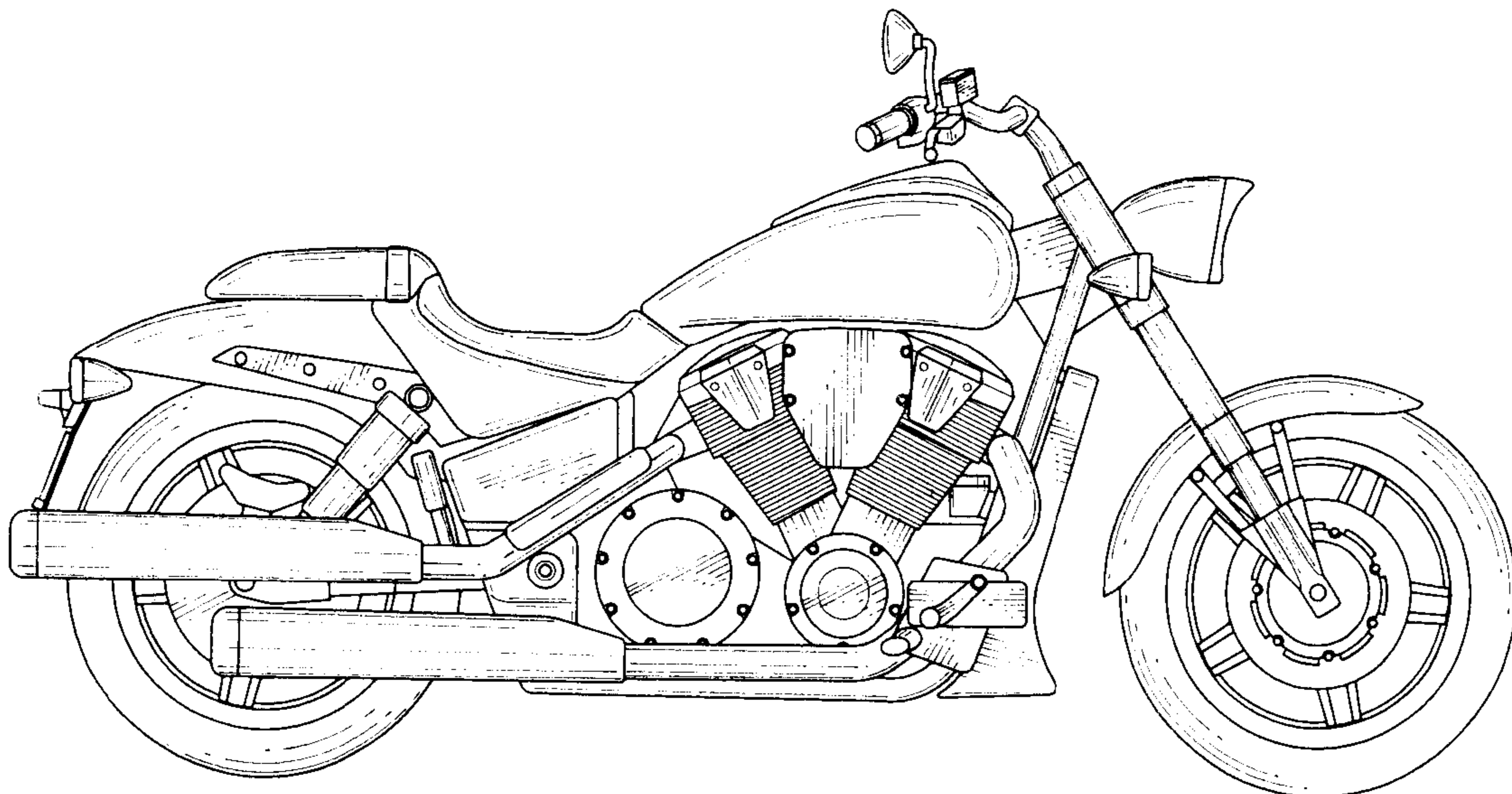

F I G. 3

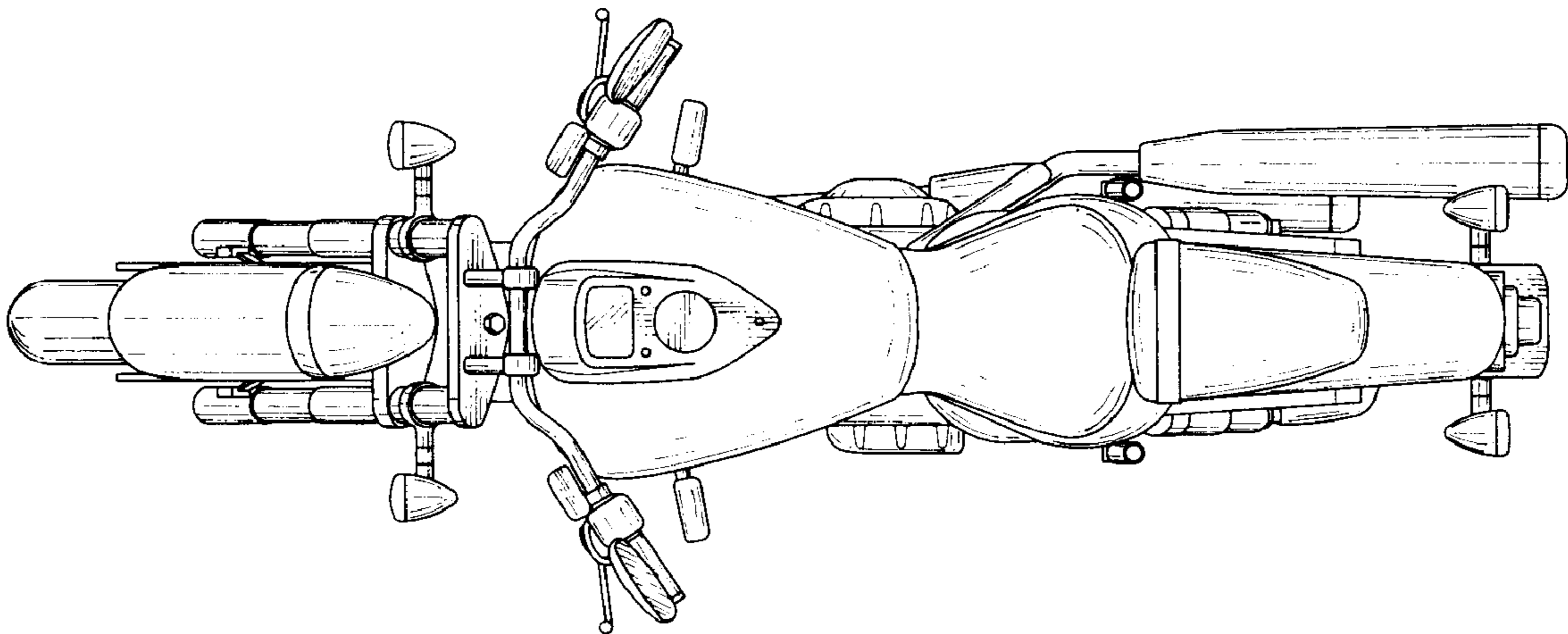

F I G. 4

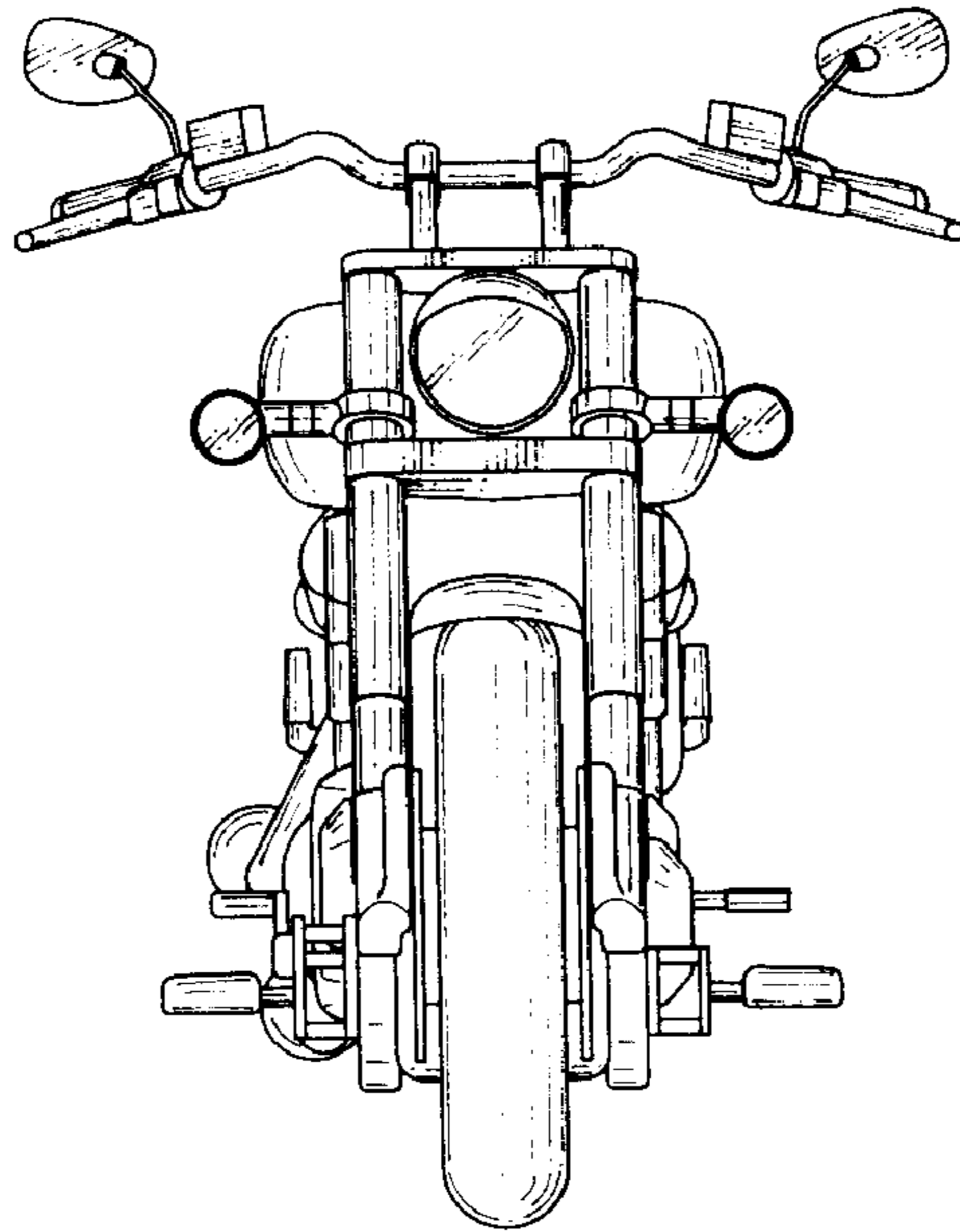

F I G. 5

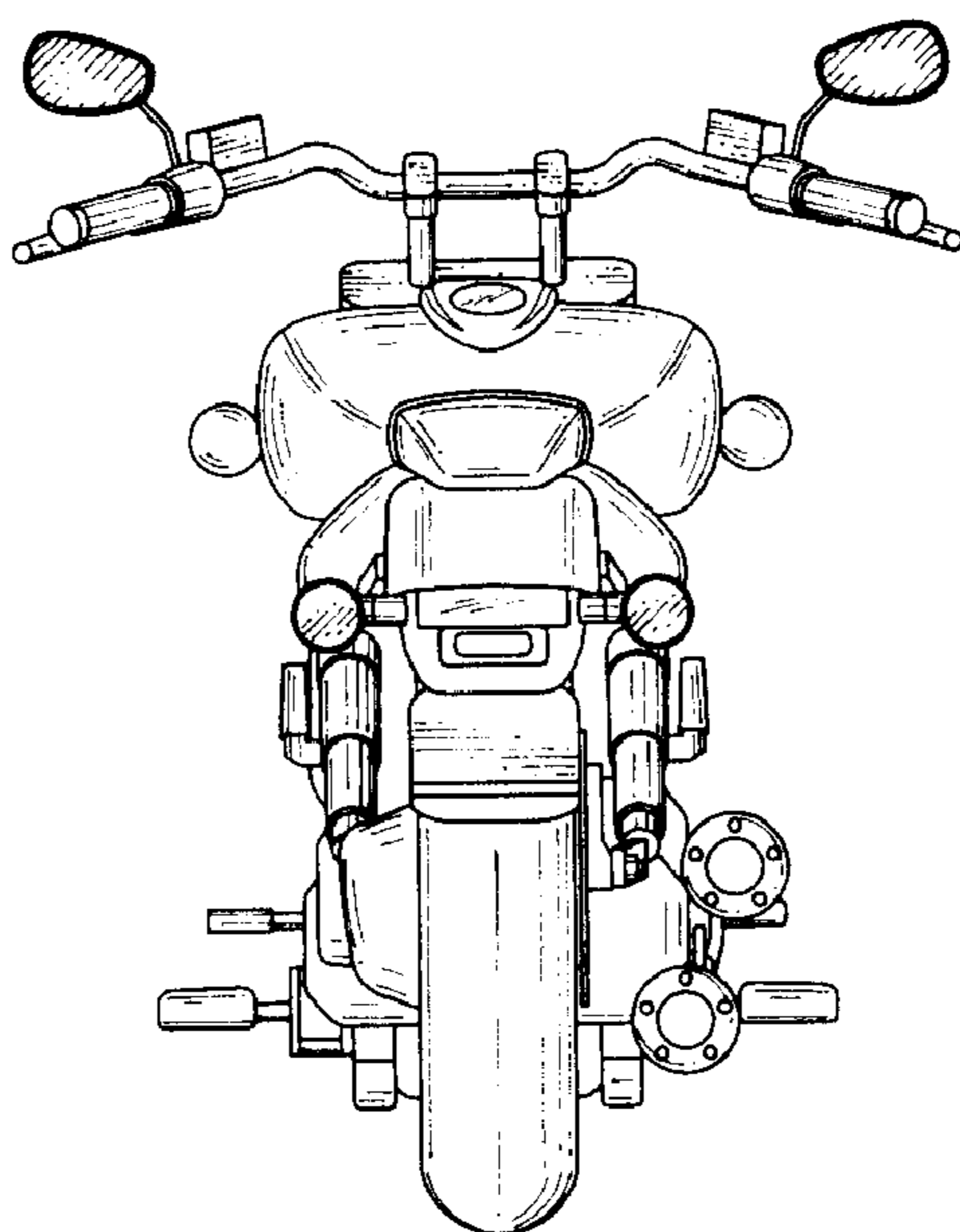

F I G. 6

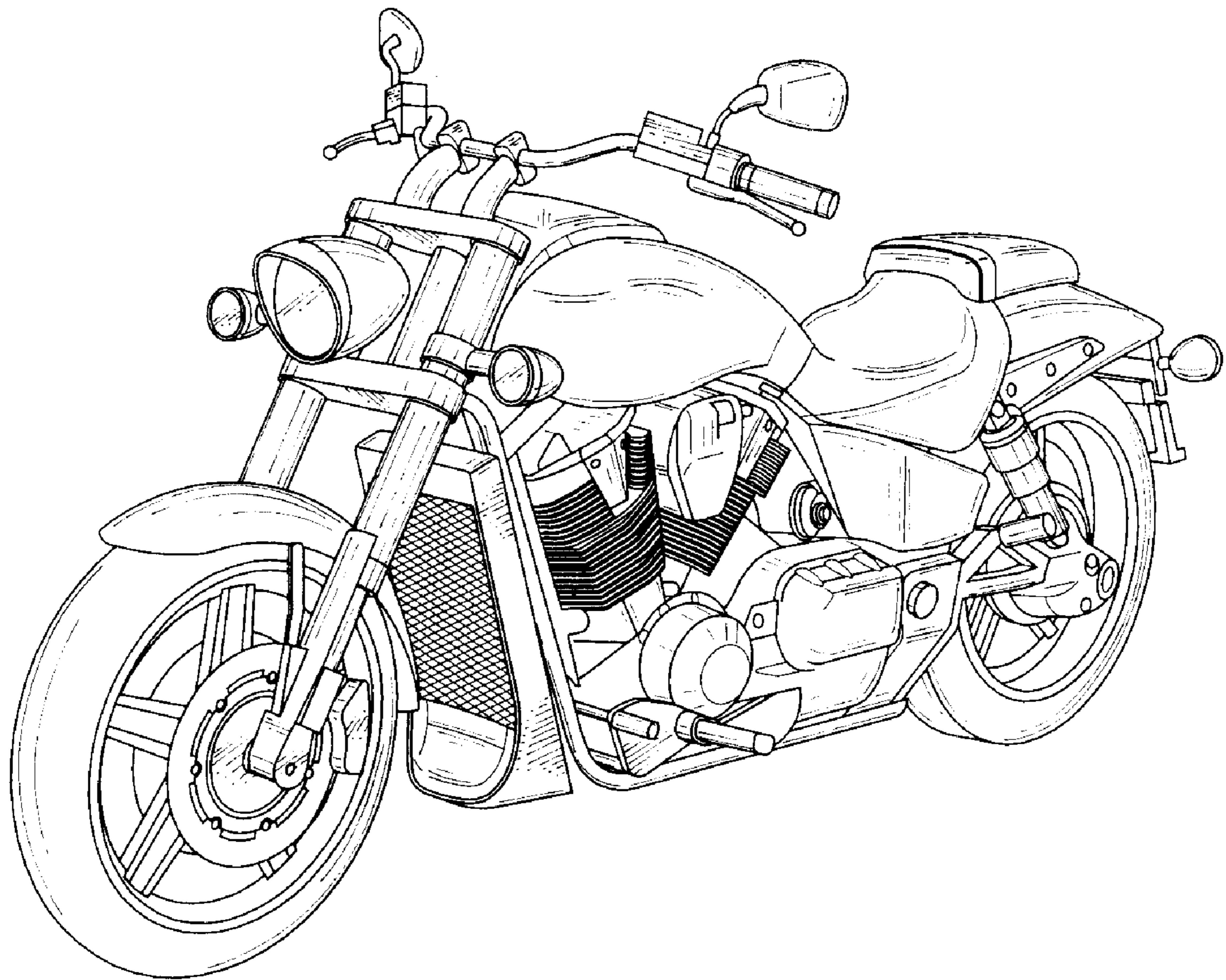

F I G. 7

