



US00D511715S

(12) **United States Design Patent** (10) **Patent No.:** **US D511,715 S**
Hohnl et al. (45) **Date of Patent:** **** Nov. 22, 2005**

(54) **UTILITY VEHICLE**

(75) Inventors: **Gary David Hohnl**, Slinger, WI (US); **Michael Bedis**, Oconomowoc, WI (US); **James Heinrich Weitz**, Hoboken, NJ (US); **Alberto Mantilla**, Rego Park, NY (US); **Anthony John Baxter**, Hoboken, NJ (US); **Michael Patrick McCarren**, Charlotte, NC (US)

(73) Assignee: **Deere & Company**, Moline, IL (US)

(**) Term: **14 Years**

(21) Appl. No.: **29/208,425**

(22) Filed: **Jun. 29, 2004**

(51) **LOC (8) Cl.** **12-14**

(52) **U.S. Cl.** **D12/14**

(58) **Field of Search** D12/1, 14-16,
D12/82, 86-93; 296/28, 37.7, 184-186;
180/908; 280/DIG. 5; D21/803; D15/28,
30

(56) **References Cited**

U.S. PATENT DOCUMENTS

D292,899 S	*	11/1987	Samuelson et al.	D12/16
4,773,675 A	*	9/1988	Kosuge	280/781
D342,701 S	*	12/1993	Murata et al.	D12/107
5,509,710 A	*	4/1996	Eavenson et al.	296/19
D436,557 S	*	1/2001	Selby et al.	D12/14
D439,549 S	*	3/2001	Shambeau et al.	D12/14
D445,066 S	*	7/2001	Hinklin et al.	D12/1
D472,717 S	*	4/2003	Buckle	D5/46

OTHER PUBLICATIONS

- John Deere—Gator, Utility Vehicle Brochure.
- John Deere—Gator, Utility Vehicle Brochure.
- Mark 4 Haul Master—Brochure.
- Club Car Utility Vehicle—Brochure.
- Cushman Turf Utility Vehicles—Brochure.
- Cushman Turf Care (Increased Capacity 2600 lb 4-wheel & 2500 lb 3-wheel)—Brochure.
- Cushman GT America—Brochure.
- Cushman Hawk—Brochure.

- E-Z-GO Turf Vehicles—Brochure.
- Jacobsen 610 Express / 810 Express Utility Trucks—Brochure, 1992.
- Jacobsen 1110 Hauler Heavy Duty Utility Vehicle—Brochure, 1996.
- Jacobsen SV-3422 SV-2322 System Vehicles—Brochure 1994.
- Kawasaki MULE 500—Brochure, 1990.
- Kawasaki MULE 2010/1000—Brochure, 1990.
- Kawasaki MULE 1000/2510—Brochure, 1992.
- Kawasaki Utility Vehicle—Brochure, 1987.
- Noland Turf Vehicles—Brochure.
- Raptor Accessories, Koyker Manufacturing Co., Sep. 1998.
- RAPTOR Utility Vehicles, Koyker Manufacturing Co., Feb. 1998.
- Taylor-Dunn Industrial Trucks—Brochure, 1988.

* cited by examiner

Primary Examiner—Nelson C. Holtje

(57) **CLAIM**

The ornamental design for a utility vehicle, as shown and described.

DESCRIPTION

FIG. 1 is an elevated left front perspective view of a utility vehicle showing our new design, the broken line showing being for illustrative purposes only, and forms no part of the claimed design.

FIG. 2 is an elevated right rear perspective view of a utility vehicle showing our new design, the broken line showing being for illustrative purposes only, and forms no part of the claimed design.

FIG. 3 is a front view of a utility vehicle showing our new design, the broken line showing being for illustrative purposes only, and forms no part of the claimed design.

FIG. 4 is a rear view of a utility vehicle showing our new design, the broken line showing being for illustrative purposes only, and forms no part of the claimed design; and, FIG. 5 is a right side view of a utility vehicle showing our new design, the broken line showing being for illustrative purposes only, and forms no part of the claimed design.

1 Claim, 5 Drawing Sheets

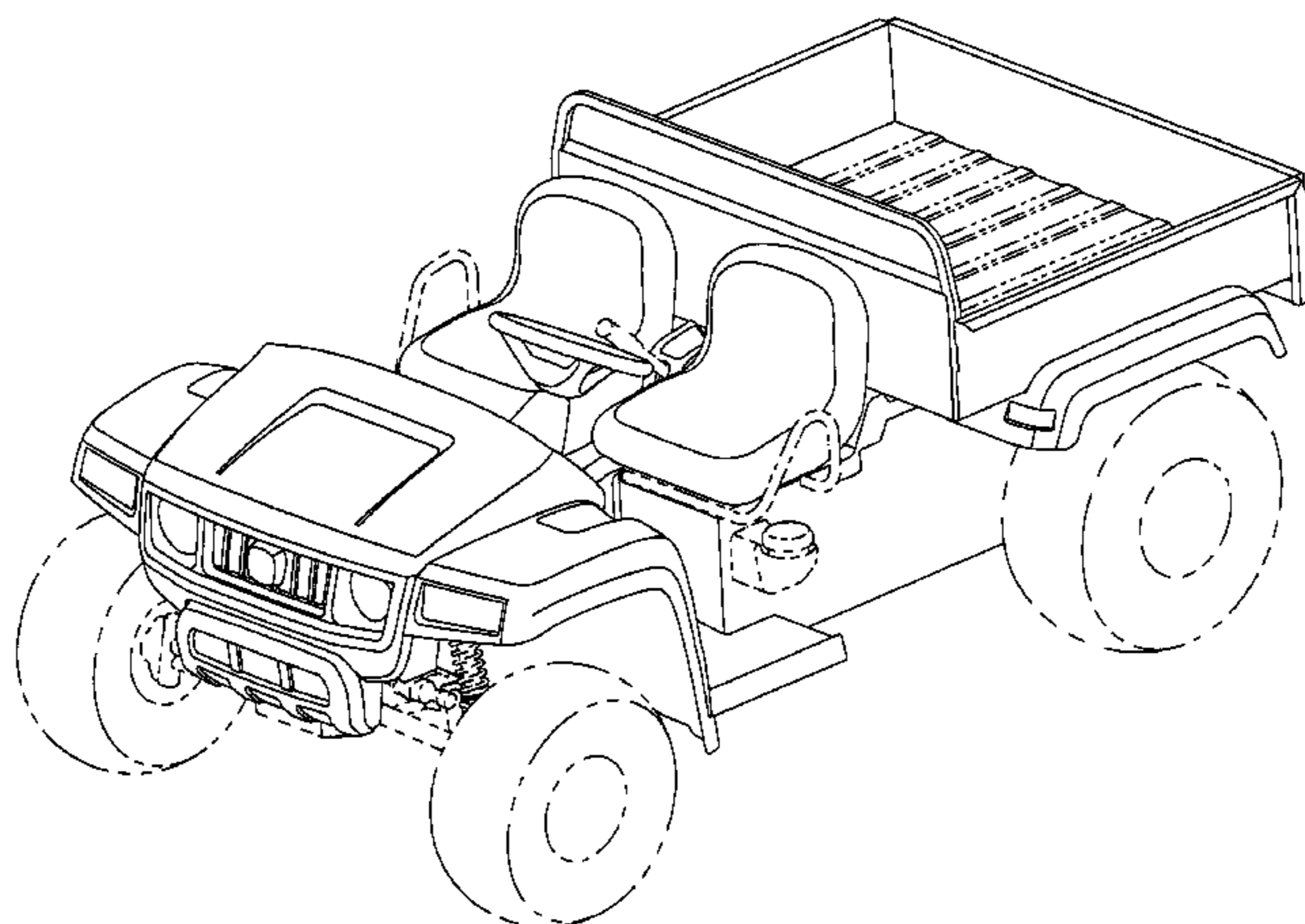

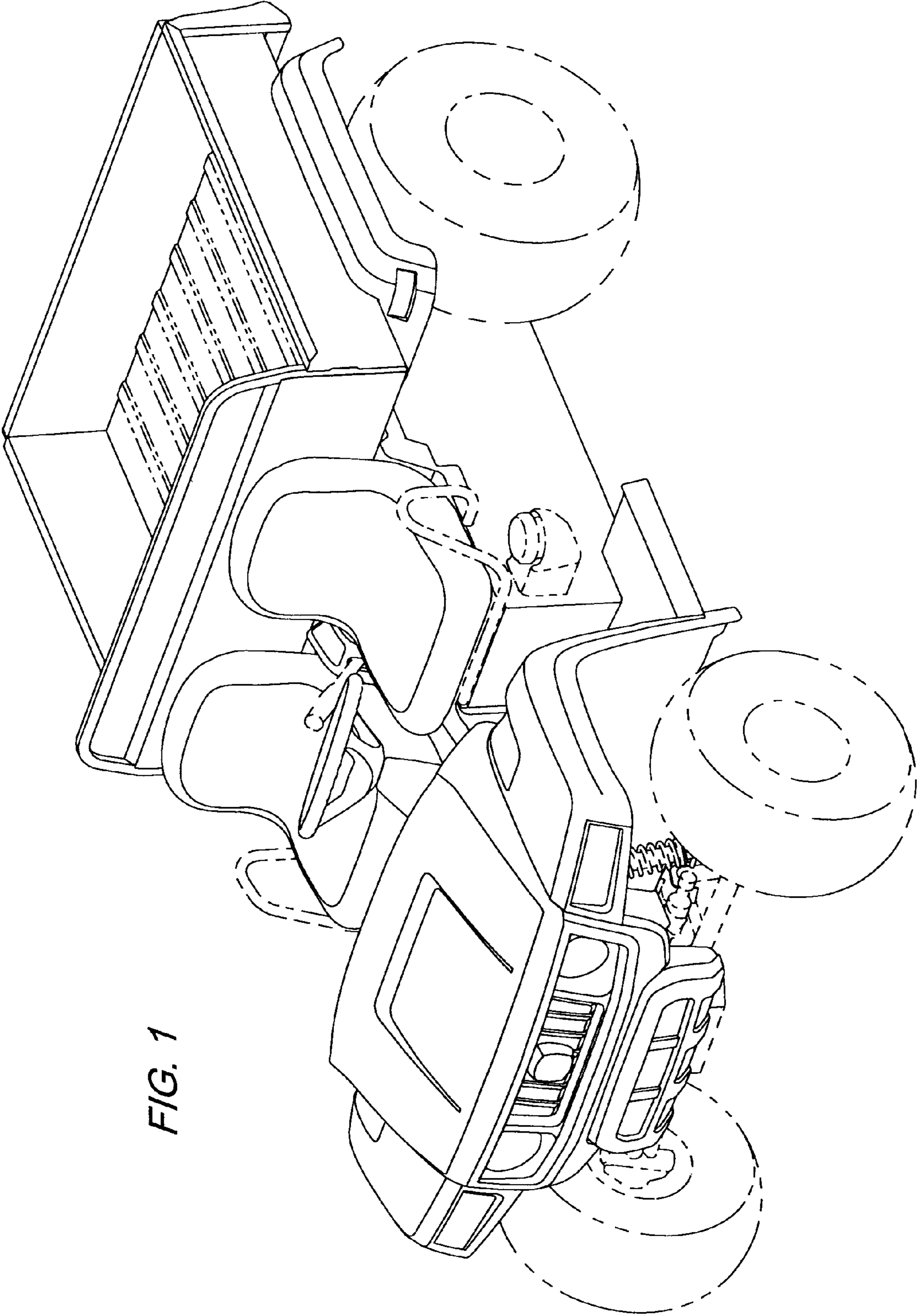

FIG. 1

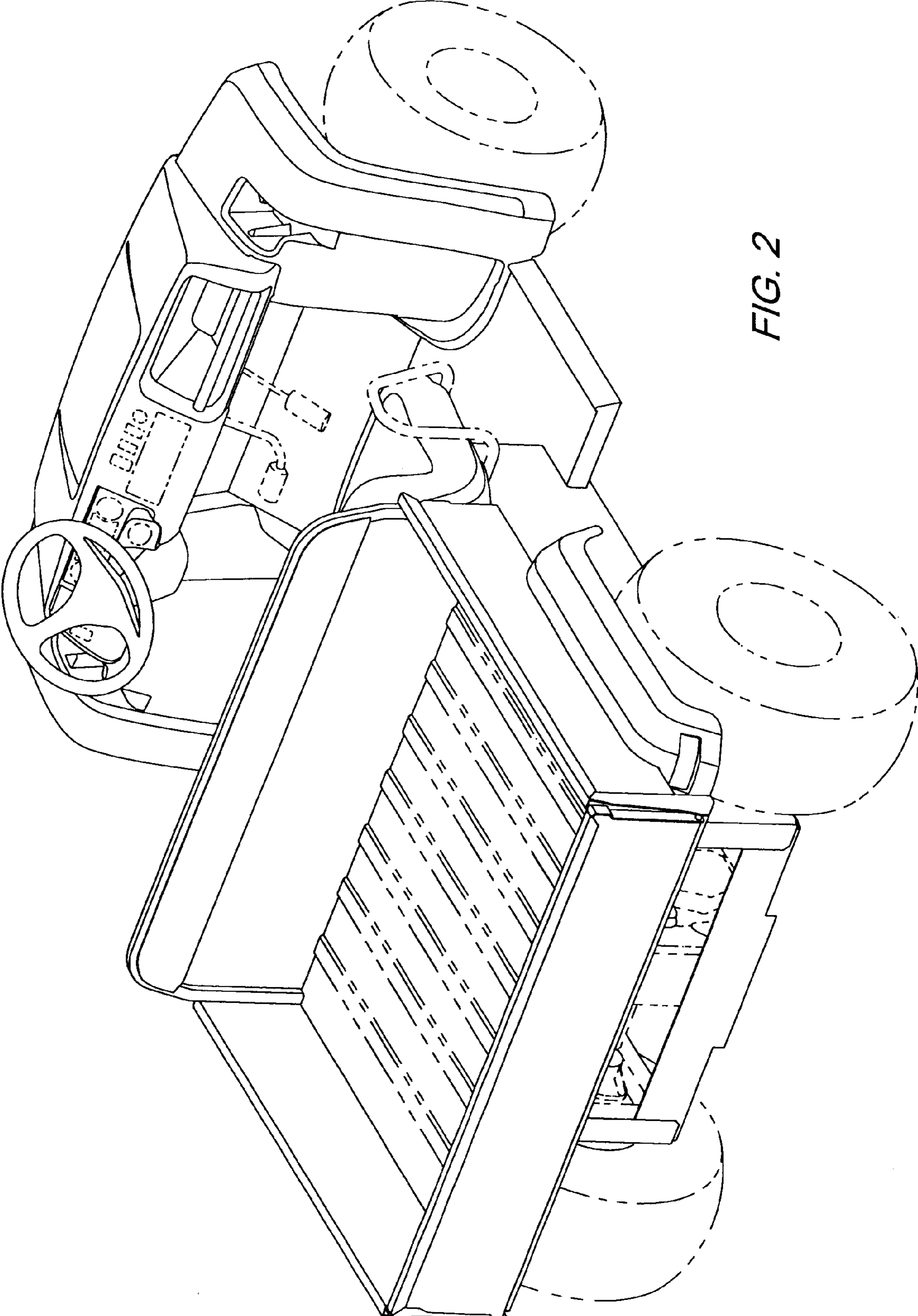

FIG. 2

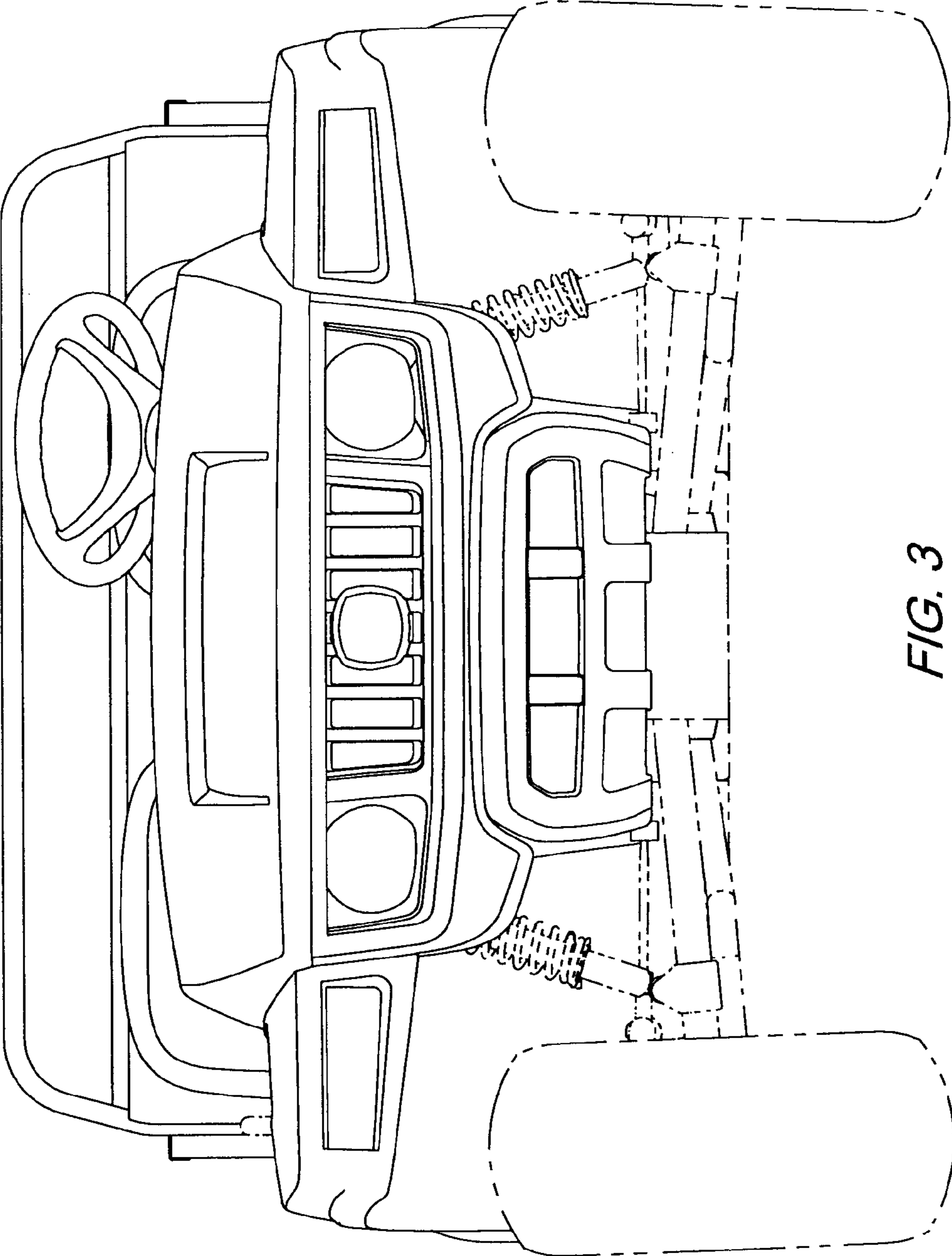

FIG. 3

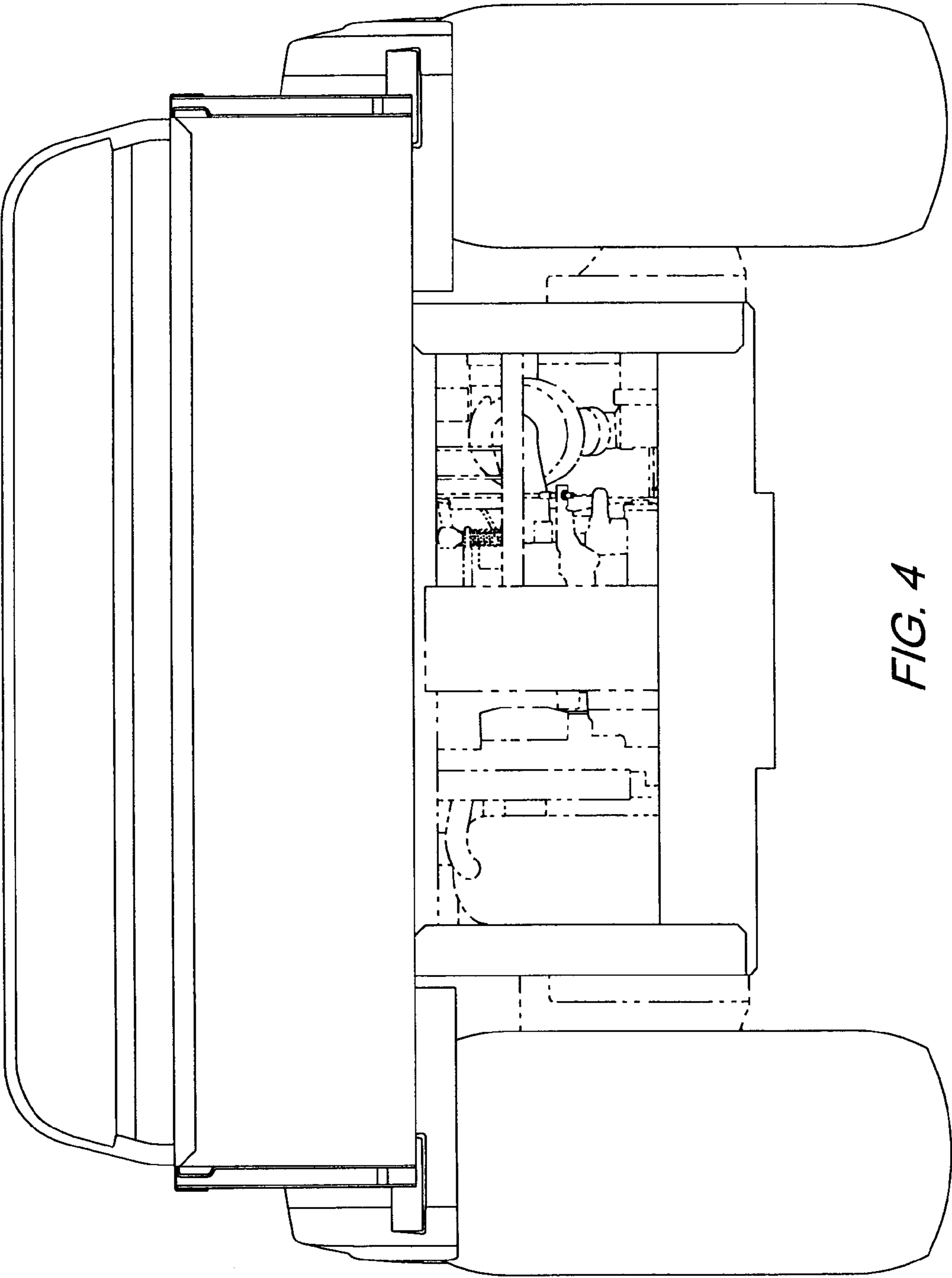

FIG. 4

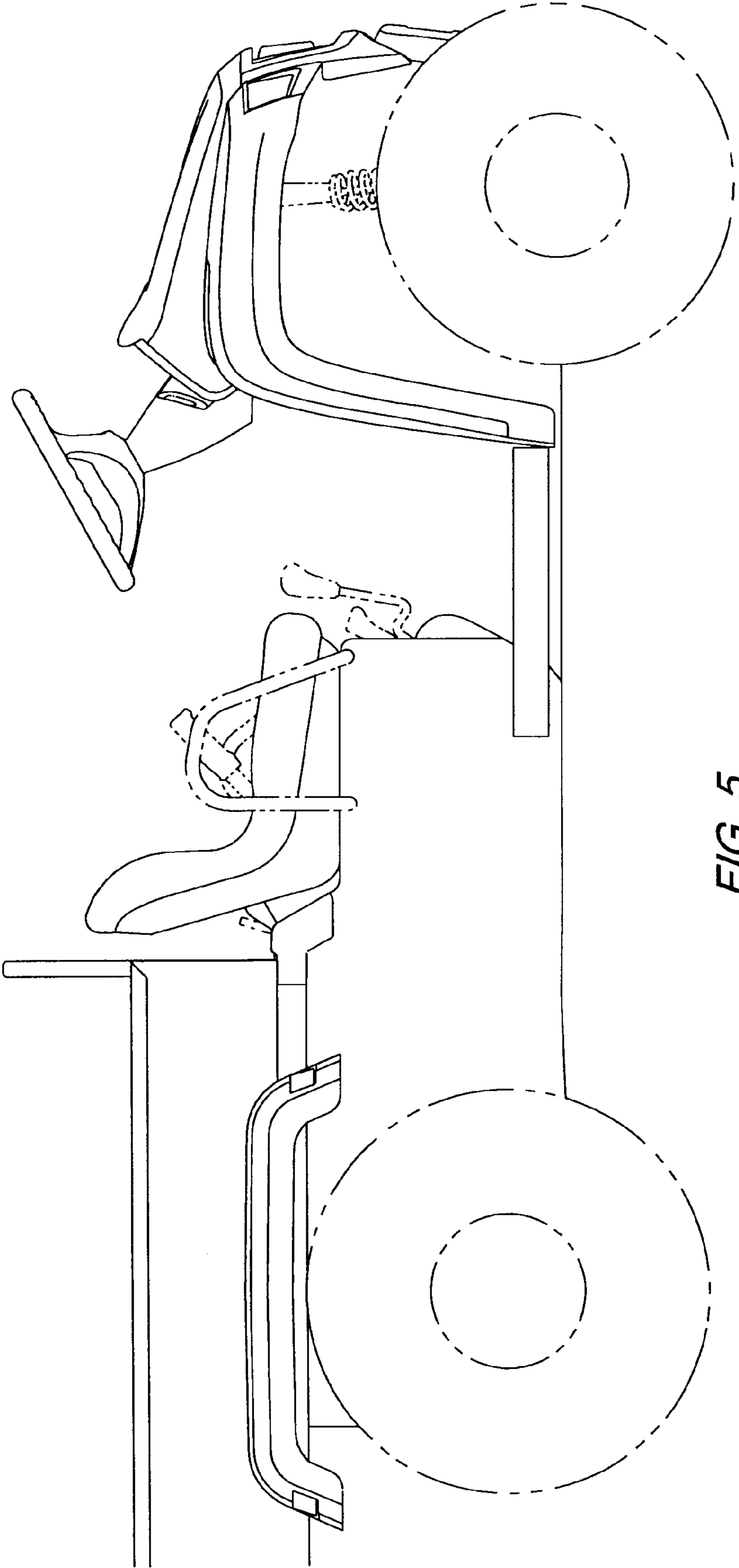

FIG. 5