



US00D511585S

(12) **United States Design Patent**
Manchester et al.

(10) **Patent No.:** **US D511,585 S**

(45) **Date of Patent:** **** Nov. 15, 2005**

(54) **TAIL LIGHT FOR A MOTORCYCLE**

D477,678 S * 7/2003 Lin D26/28
D493,903 S * 8/2004 Otsubo et al. D26/28

(75) Inventors: **Martin Gayle Manchester**, Long Beach, CA (US); **Kenji Watanabe**, Rancho Palos Verdes, CA (US); **Yoshihiro Takanashi**, Wako (JP)

* cited by examiner

Primary Examiner—Marcus A. Jackson
(74) *Attorney, Agent, or Firm*—Birch, Stewart, Kolasch & Birch, LLP.

(73) Assignee: **Honda Motor Co., Ltd.**, Tokyo (JP)

(**) Term: **14 Years**

(57) **CLAIM**

The ornamental design for a tail light for a motorcycle, as shown and described.

(21) Appl. No.: **29/211,694**

(22) Filed: **Aug. 20, 2004**

DESCRIPTION

(30) **Foreign Application Priority Data**

Mar. 29, 2004 (JP) 2004-009484

This design application is related to Patent Application No. 2004-009484 filed in Japan on Mar. 29, 2004, the entire contents of which are hereby incorporated by reference.

(51) **LOC (8) Cl.** **26-06**

(52) **U.S. Cl.** **D26/28**

(58) **Field of Search** D26/28-36; 362/457-468, 362/475-478, 485-487

FIG. 1 is a front elevation view of tail light for a motorcycle, showing our new design;

FIG. 2 is a top plan view thereof;

FIG. 3 is a right side elevation view thereof;

FIG. 4 is a left side elevation view thereof; and,

FIG. 5 is a perspective view thereof.

(56) **References Cited**

U.S. PATENT DOCUMENTS

D471,999 S * 3/2003 Yoshida et al. D26/28

1 Claim, 3 Drawing Sheets

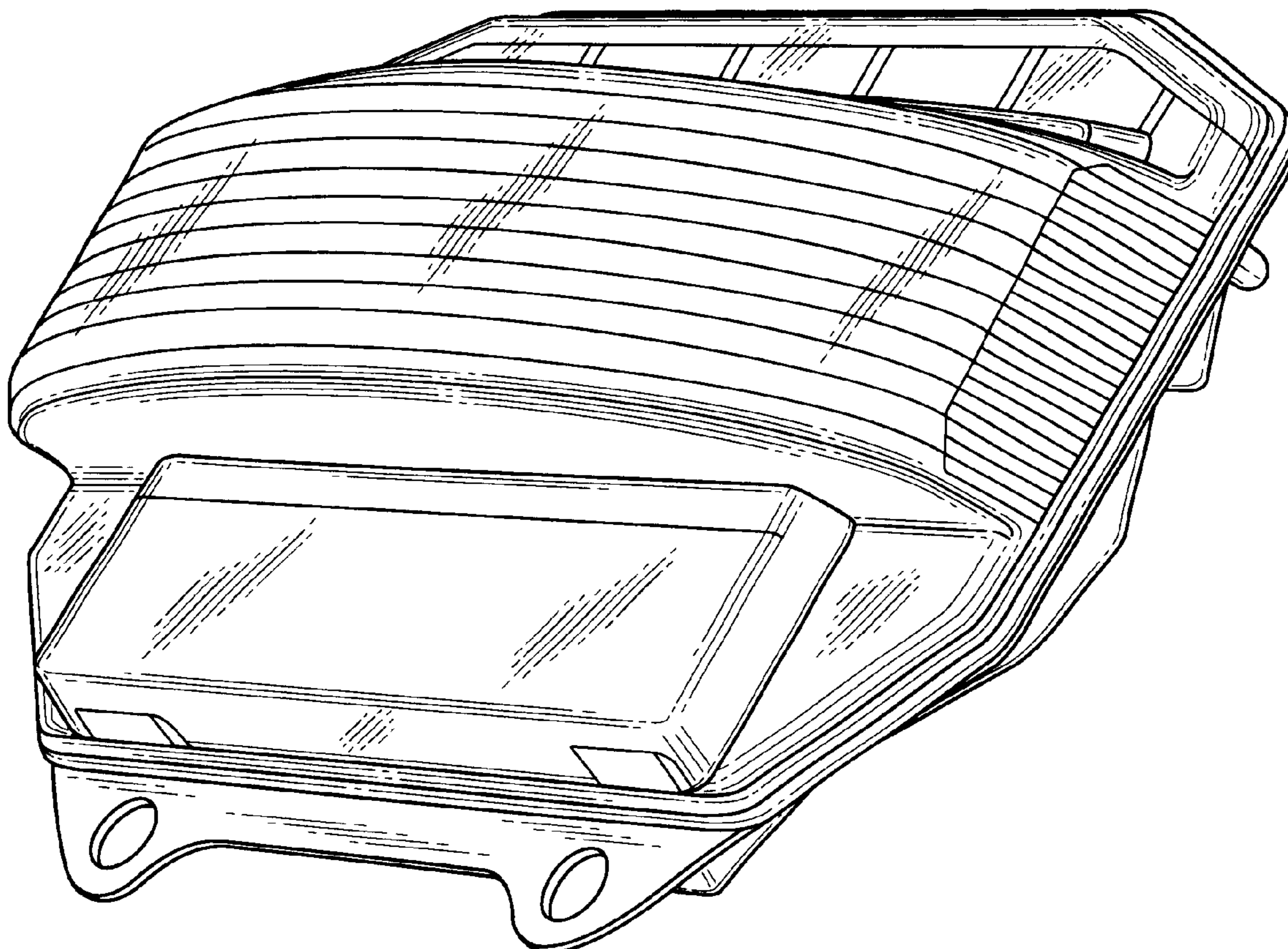

Fig. 1

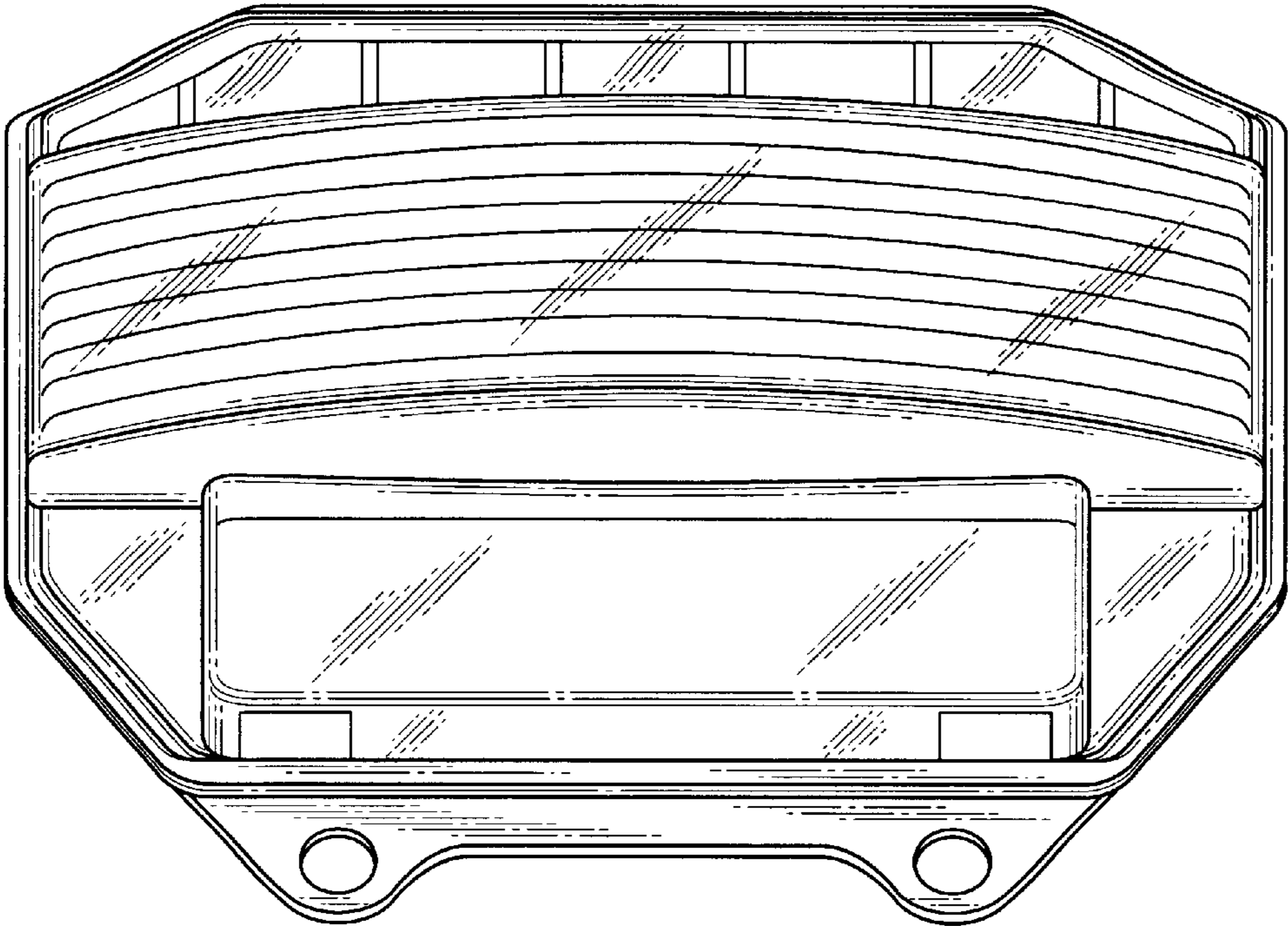

Fig. 2

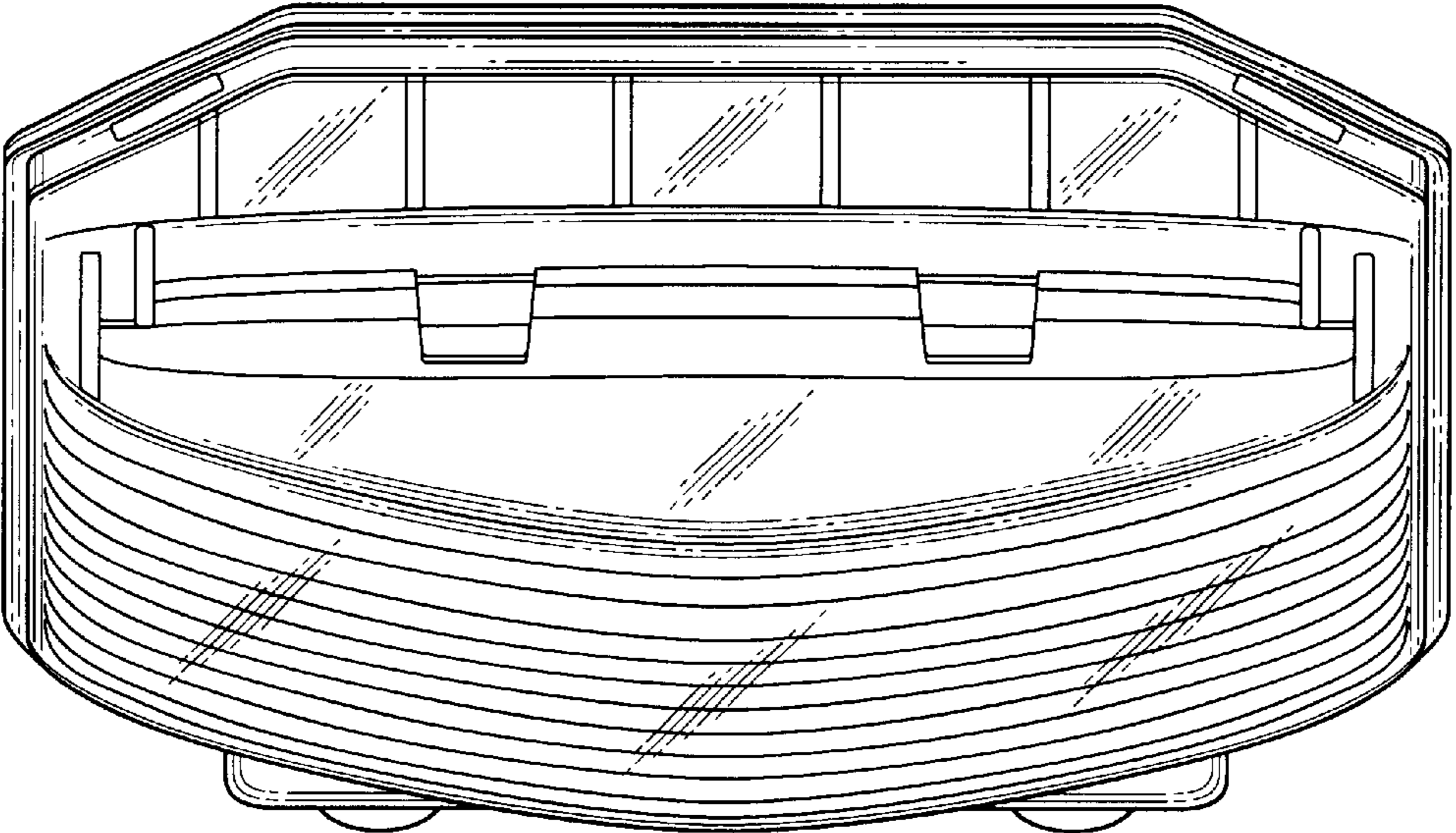

Fig. 3

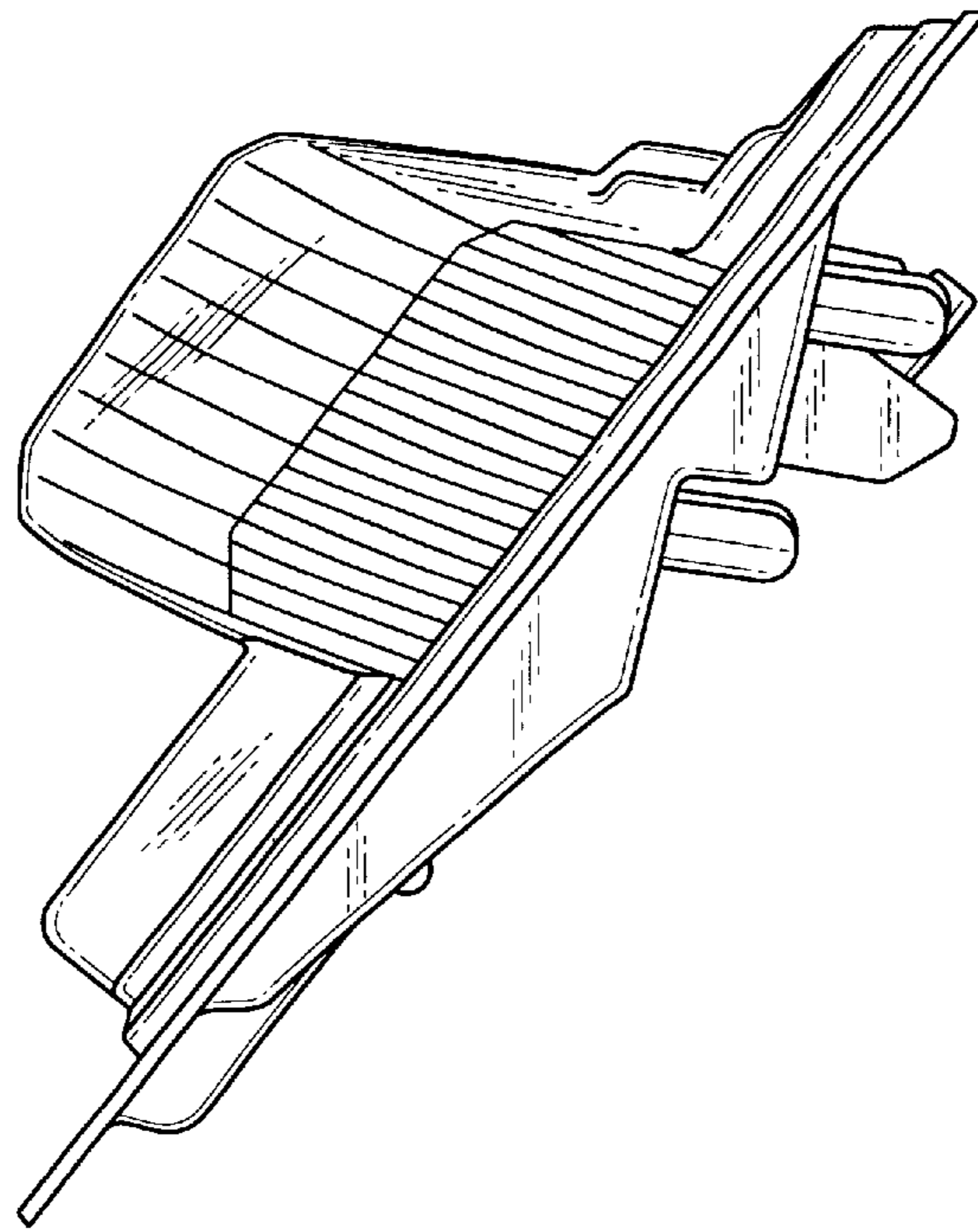

Fig. 4

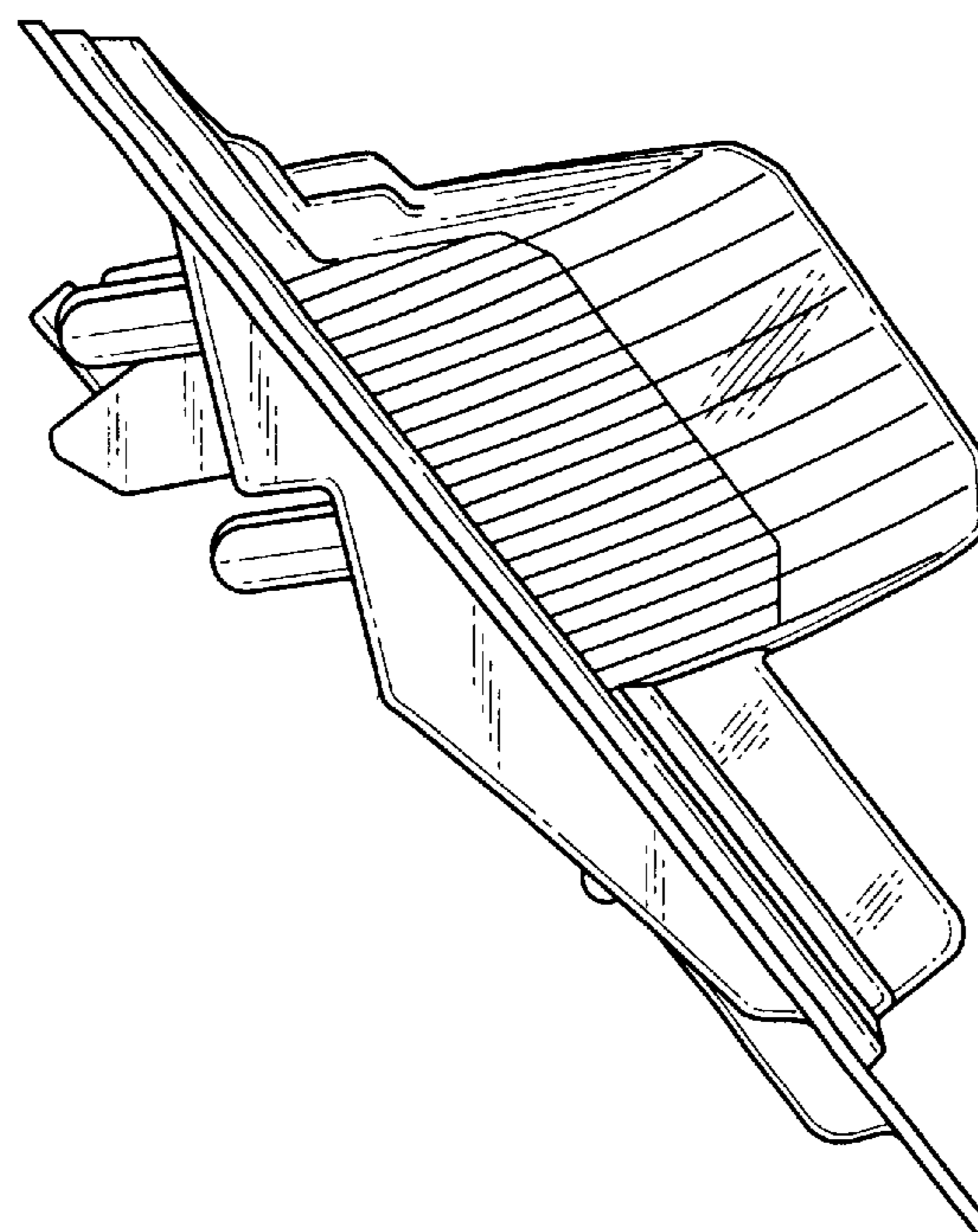

Fig. 5

