



US00D511500S

(12) **United States Design Patent**  
**Mahoney**

(10) **Patent No.:** **US D511,500 S**  
(45) **Date of Patent:** **\*\* Nov. 15, 2005**

(54) **GROUND WIRE CONNECTION PORTION**

(75) Inventor: **William G. Mahoney**, Suwanee, GA  
(US)

(73) Assignee: **Scientific-Atlanta, Inc.**, Lawrenceville,  
GA (US)

(\*\*) Term: **14 Years**

(21) Appl. No.: **29/204,781**

(22) Filed: **May 4, 2004**

(51) **LOC (8) Cl.** ..... **13-03**

(52) **U.S. Cl.** ..... **D13/154**

(58) **Field of Search** ..... D13/146, 147,  
D13/154; 174/66; 439/76.1, 350, 357, 358,  
491, 607, 610

6,394,507 B1	5/2002	Baker	.....	285/368
6,428,357 B1	8/2002	Dolinshek et al.	.....	439/606
6,435,911 B1	8/2002	Payson et al.	.....	439/606
6,443,764 B2	9/2002	Makita	.....	439/587
6,478,608 B1	11/2002	Grant et al.	.....	439/468
6,483,032 B2 *	11/2002	Adams	.....	174/66
D467,228 S *	12/2002	Shi et al.	.....	D13/147
6,576,838 B2 *	6/2003	Matsumura	.....	174/66
D478,550 S	8/2003	Garver	.....	D13/146
6,679,730 B2	1/2004	Dye et al.	.....	439/606

\* cited by examiner

*Primary Examiner*—Alan P. Douglas

*Assistant Examiner*—Cynthia M. Chin

(74) *Attorney, Agent, or Firm*—Wm. Brook Lafferty

(57) **CLAIM**

The ornamental design for a ground wire connection portion, as shown and described.

(56) **References Cited**

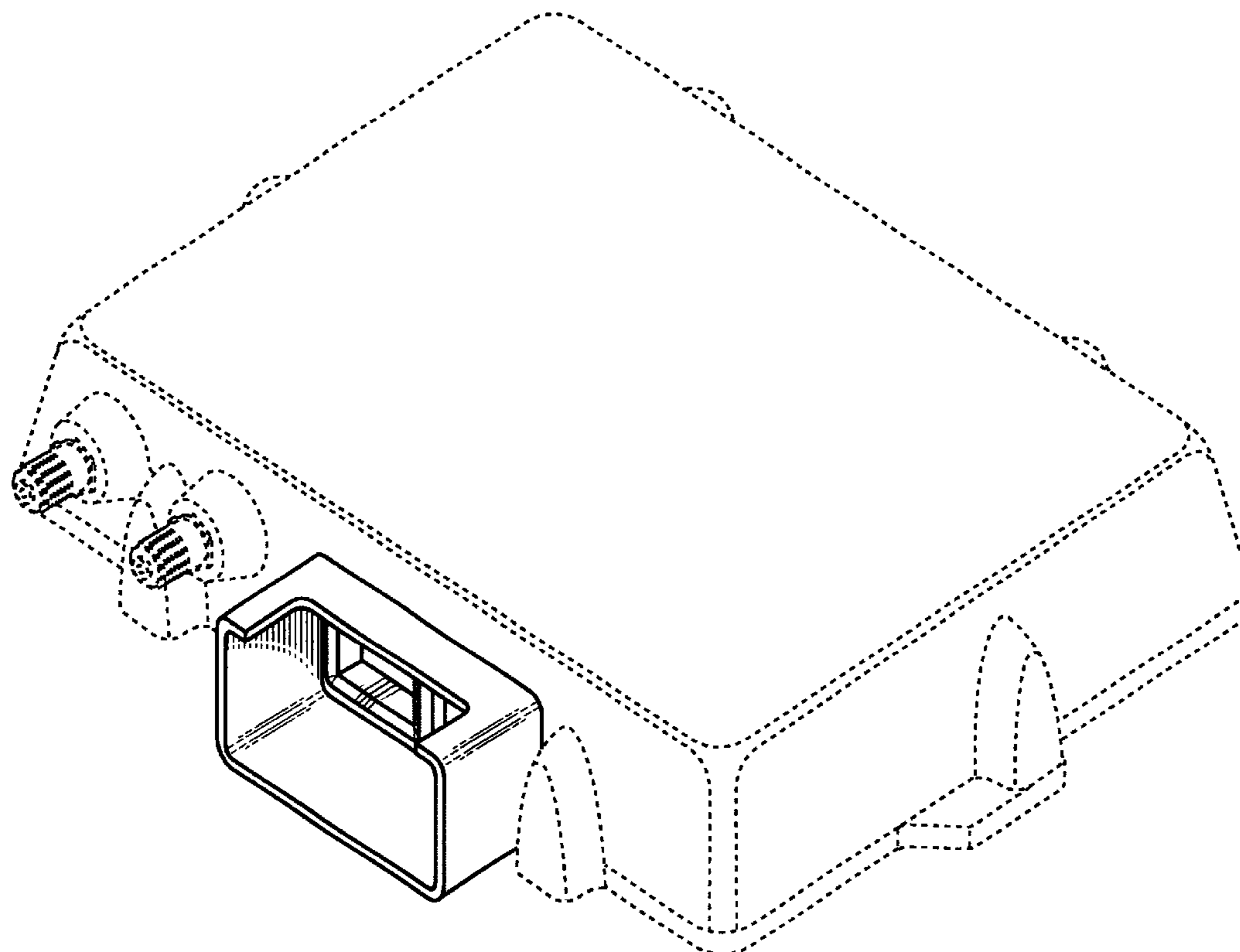
**U.S. PATENT DOCUMENTS**

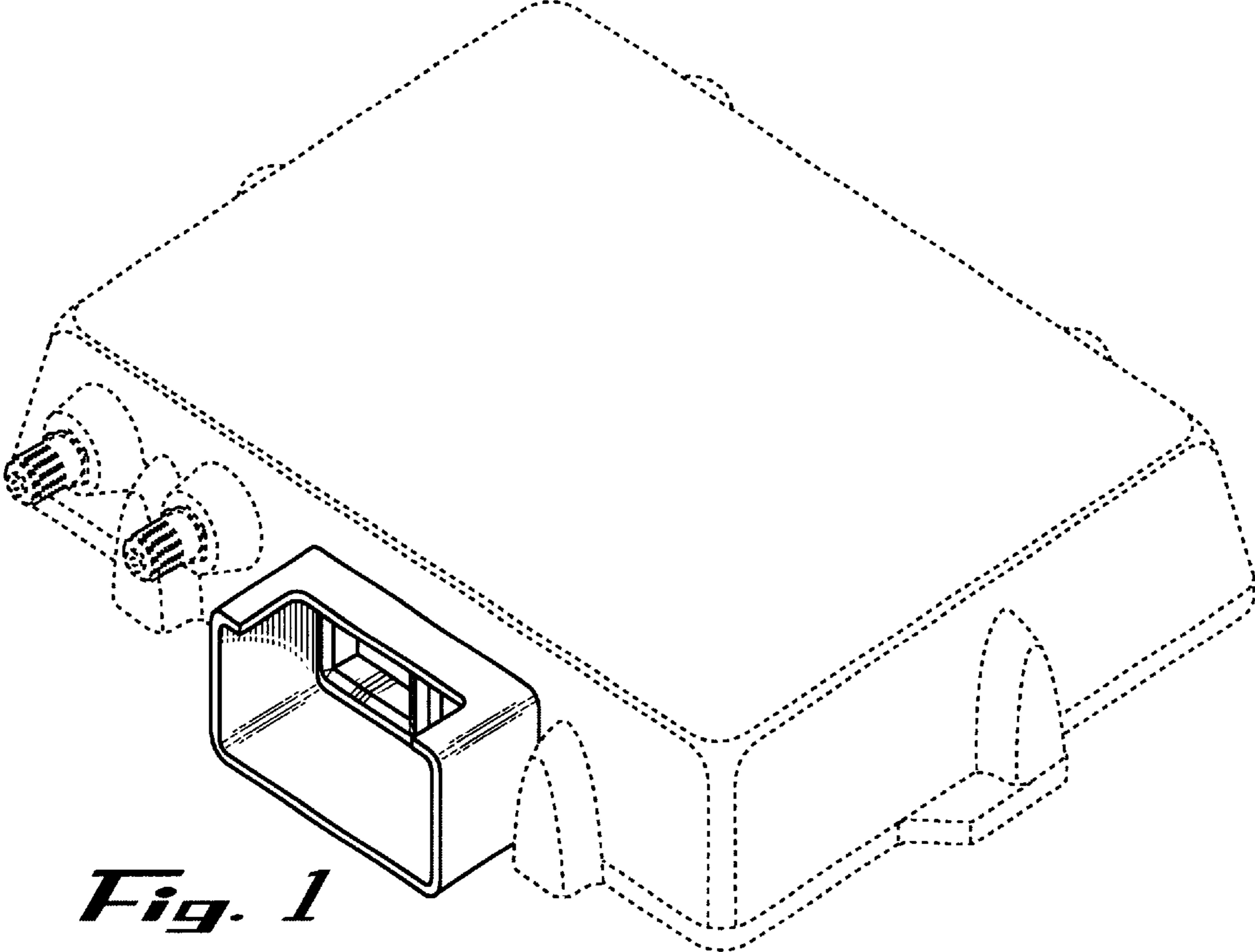
4,237,342 A	12/1980	Eller et al.	.....	179/1 PC
D321,859 S *	11/1991	Nagasaka et al.	.....	D13/146
D323,150 S *	1/1992	Takenouchi et al.	.....	D13/146
5,354,208 A	10/1994	Salaski et al.	.....	439/230
5,431,583 A	7/1995	Szegda	.....	439/589
5,504,424 A	4/1996	Graf et al.	.....	324/174
D413,103 S *	8/1999	Wu	.....	D13/147
D430,542 S	9/2000	Hoferitza et al.	.....	D13/154
6,148,862 A	11/2000	Doll	.....	137/884
6,160,220 A *	12/2000	Takimura et al.	.....	174/66
6,340,250 B1	1/2002	Auclair	.....	385/87

**DESCRIPTION**

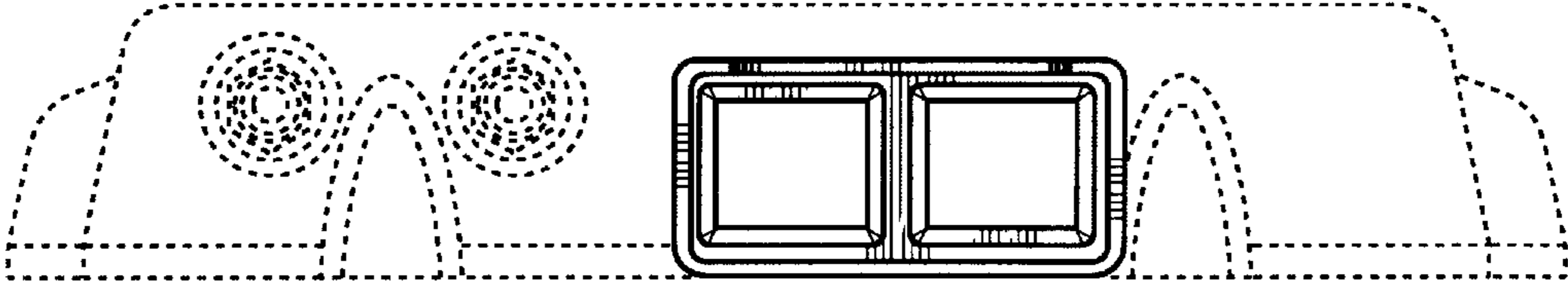
FIG. 1 is a perspective view of a new connection shroud portion according to the present invention; FIG. 2 is a front view of the design shown in FIG. 1; FIG. 3 is a left side view of the design shown in FIG. 1; FIG. 4 is a right side view of the design shown in FIG. 1; FIG. 5 is a top view of the design shown in FIG. 1; and, FIG. 6 is a bottom view of the design shown in FIG. 1. The broken lines in the drawings are for illustrative purposes only and form no part of the claimed design.

**1 Claim, 3 Drawing Sheets**

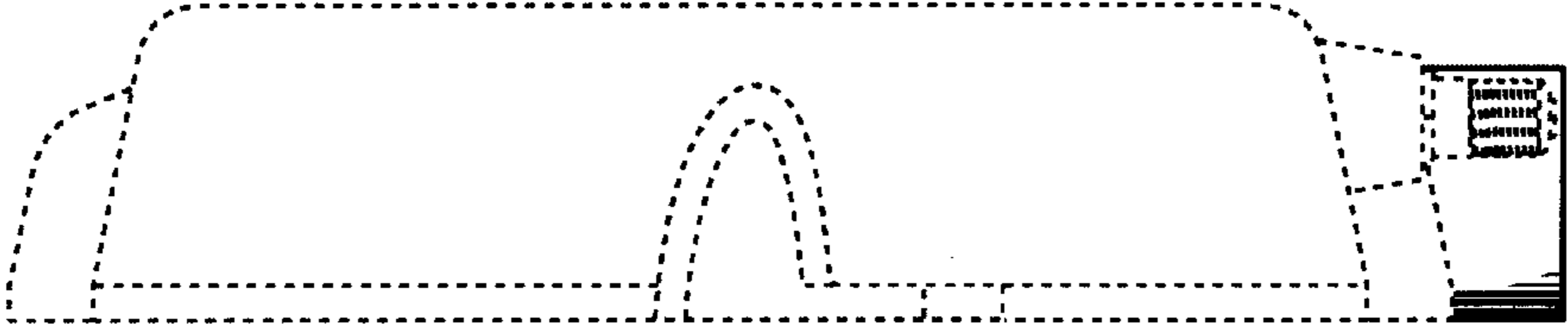




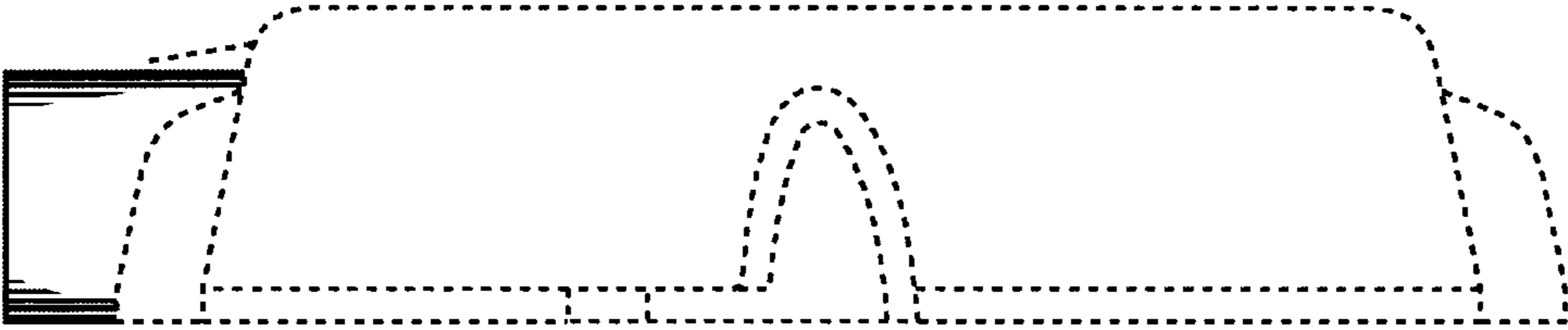
*Fig. 1*



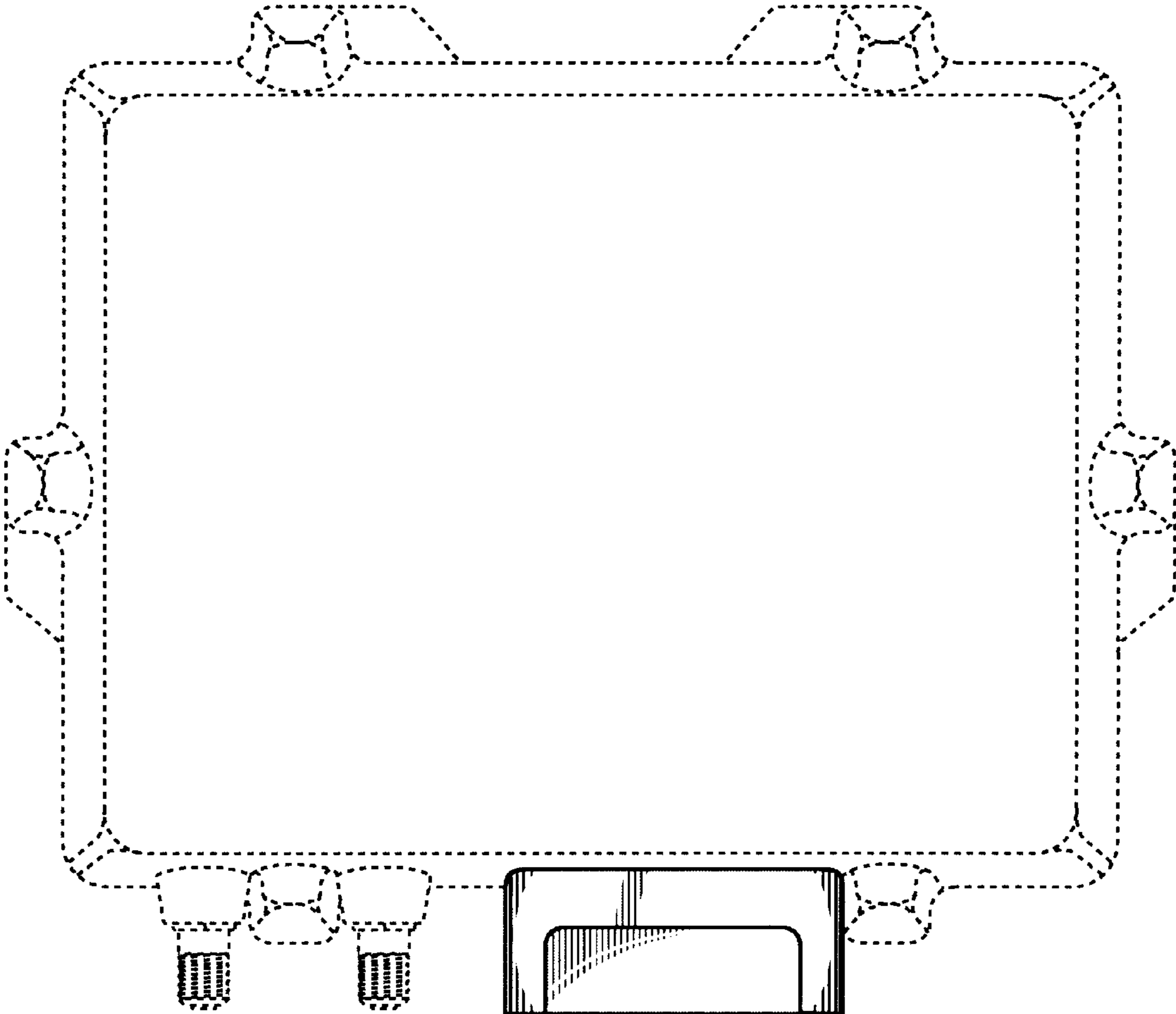
*Fig. 2*



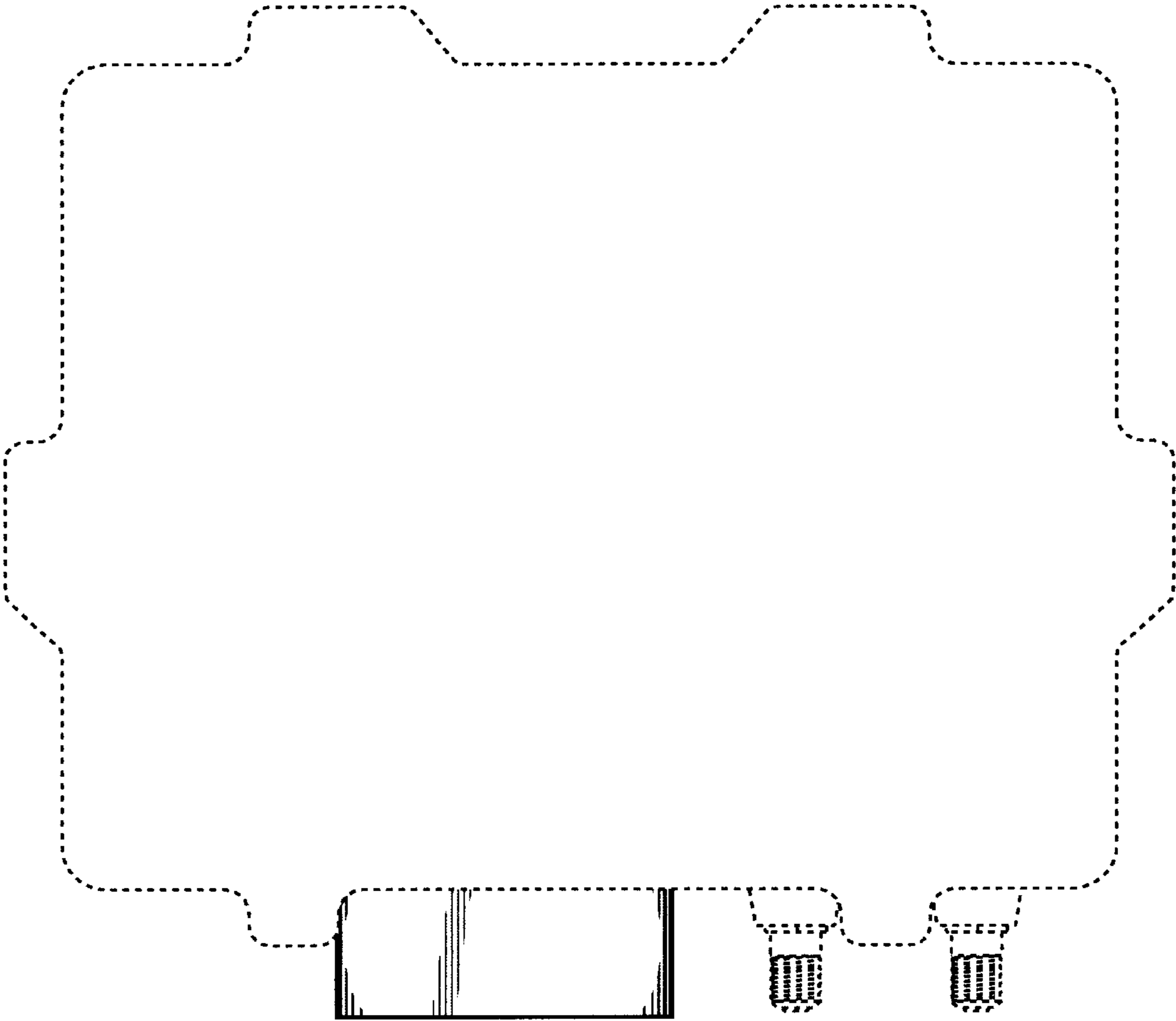
*Fig. 3*



*Fig. 4*



*Fig. 5*



*Fig. 6*