



US00D511439S

(12) **United States Design Patent**
Roybal

(10) **Patent No.:** **US D511,439 S**

(45) **Date of Patent:** **** Nov. 15, 2005**

(54) **CAN OR BOTTLE HOLDER FOR BOATS**

6,648,290 B1 * 11/2003 Aleman 248/311.2

(76) **Inventor:** **Tom J. Roybal**, 1966 Freeman Ave.,
#A, Signal Hill, CA (US) 90755

* cited by examiner

Primary Examiner—Terry A. Wallace

(**) **Term:** **14 Years**

(57) **CLAIM**

(21) **Appl. No.:** **29/207,166**

The ornamental design for can or bottle holder for boats, as shown and described.

(22) **Filed:** **Jun. 10, 2004**

DESCRIPTION

(51) **LOC (8) Cl.** **07-06**

(52) **U.S. Cl.** **D7/620; D12/420**

(58) **Field of Search** D7/619.1–625,
D7/603–608; D12/415–420; 220/737, 739,
902, 903, 592.2, 592.16, 592.17, 592.24;
224/411, 539, 558, 560, 42.11, 926; 248/311.2,
311.3, 312.1

A plastic or stainless steel hollow cylinder shaped can or bottle holder, which is open at the top and has a closed bottom with holes for easy draining. The upper edge of the hollow cylinder has an upright arm with a hooked upper end. This hook may be fastened over a safety rail, such that the beverage holder automatically pivots with the rocking motion of a boat in water. Consequently, spillage can be avoided and the drink can be stabilized, if the can or bottle is placed in the can or bottle holder.

(56) **References Cited**

U.S. PATENT DOCUMENTS

- 2,655,338 A * 10/1953 Stoger 248/311.2
- D260,471 S * 9/1981 Douglas D7/622
- 4,560,128 A * 12/1985 Willeby et al. 248/230.4
- 4,844,400 A * 7/1989 Jasmagy, Jr. 248/311.2
- 4,858,869 A * 8/1989 Stang 248/311.2
- 5,857,601 A * 1/1999 Greenwood 224/926
- 6,644,524 B1 * 11/2003 Garvin 224/411

FIG. 1 is a side view of my design;
FIG. 2 is a frontal perspective view;
FIG. 3 is a back perspective view;
FIG. 4 is a top perspective view showing the drain holes in the bottom and the mounting clip; and,
FIG. 5 is a bottom perspective view.

1 Claim, 3 Drawing Sheets

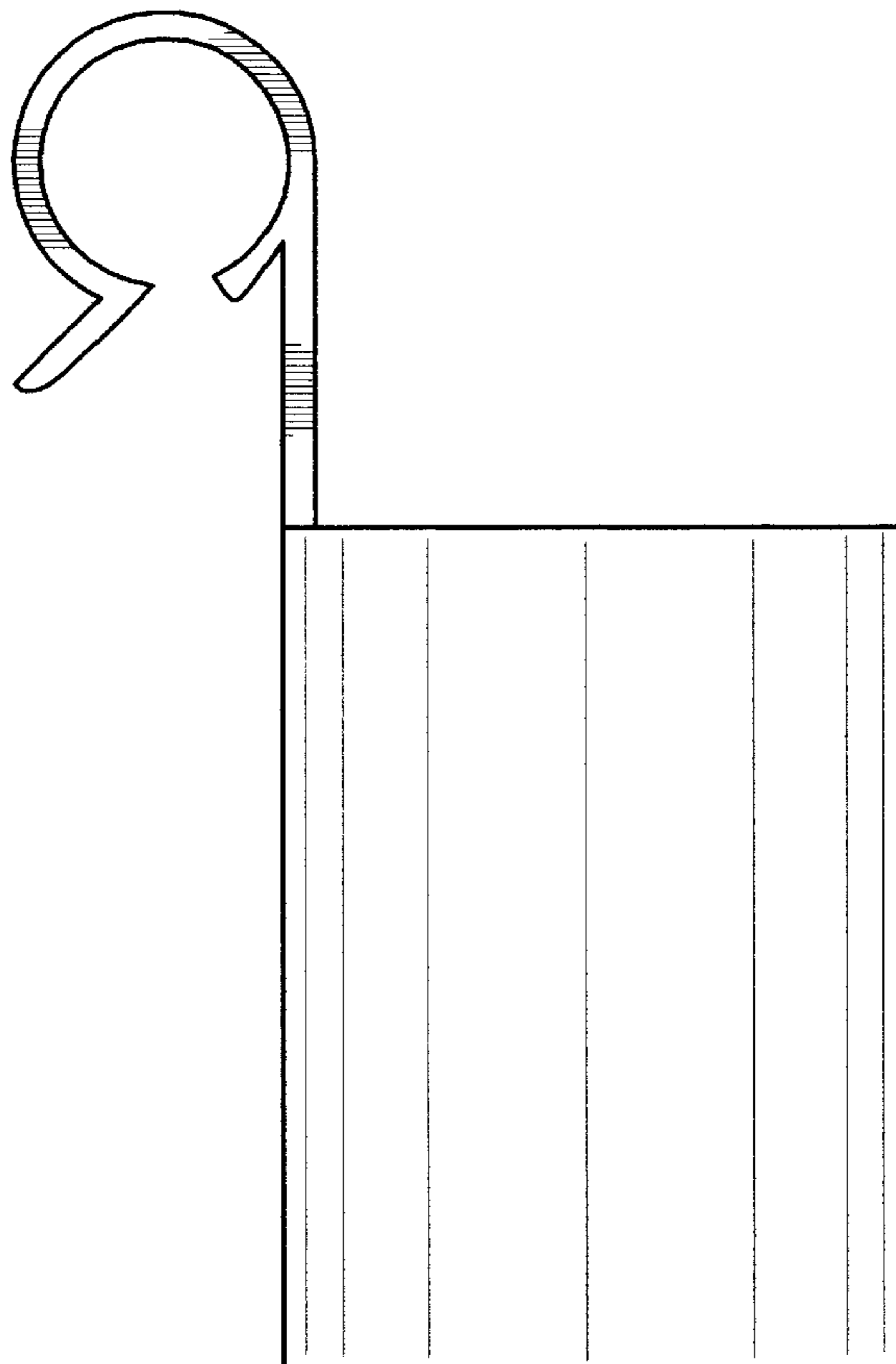

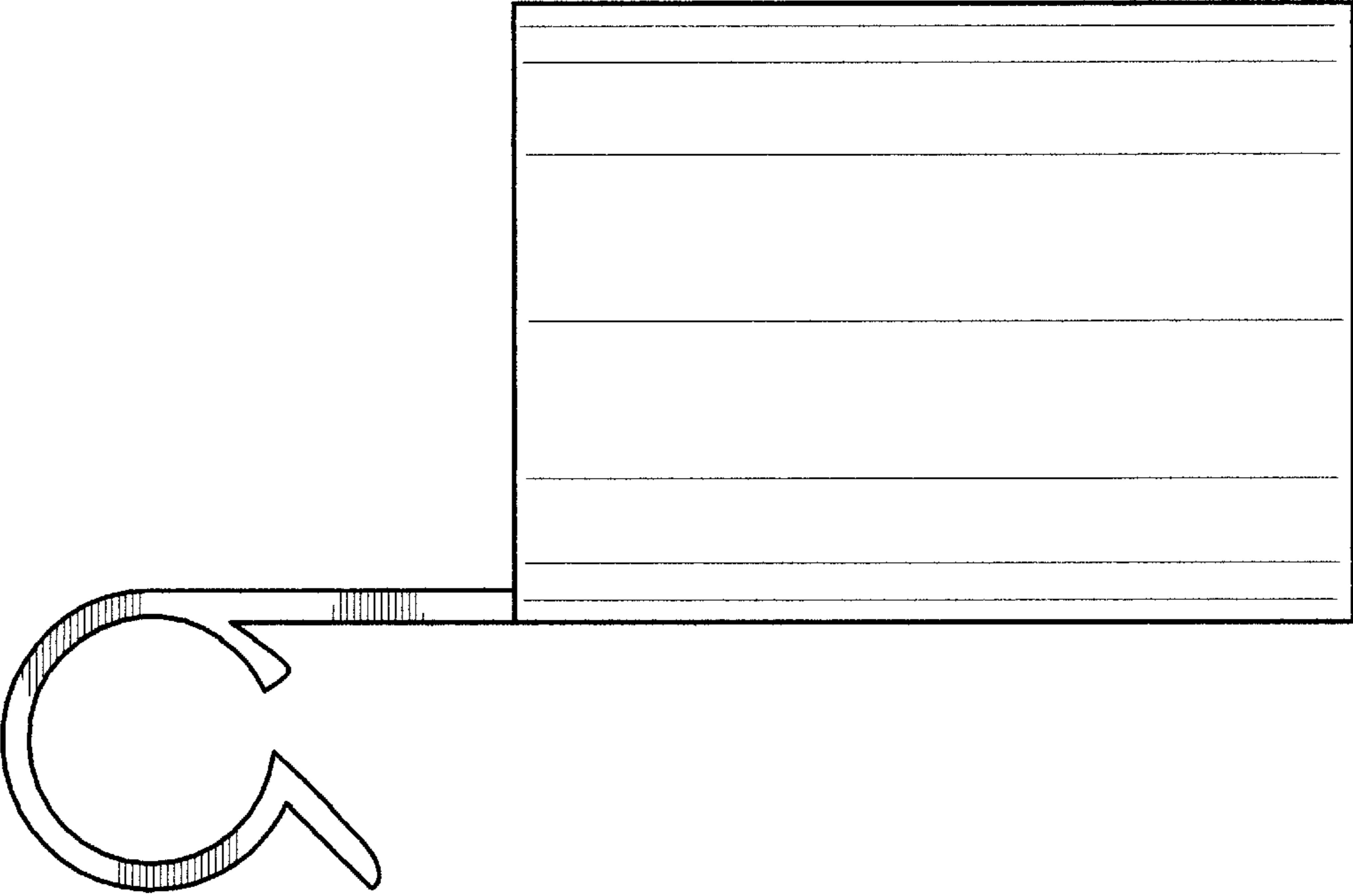

FIG. 1

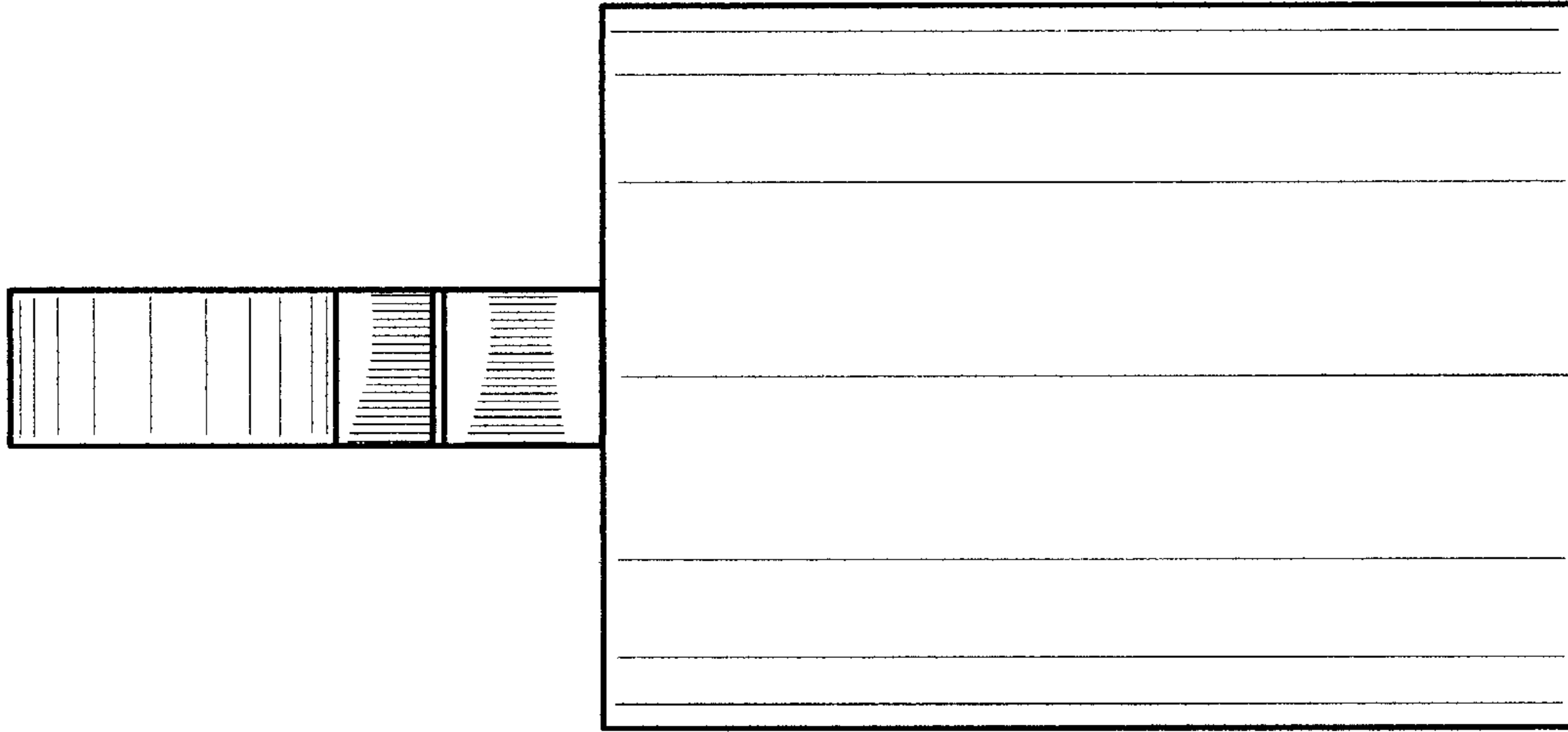

FIG. 3

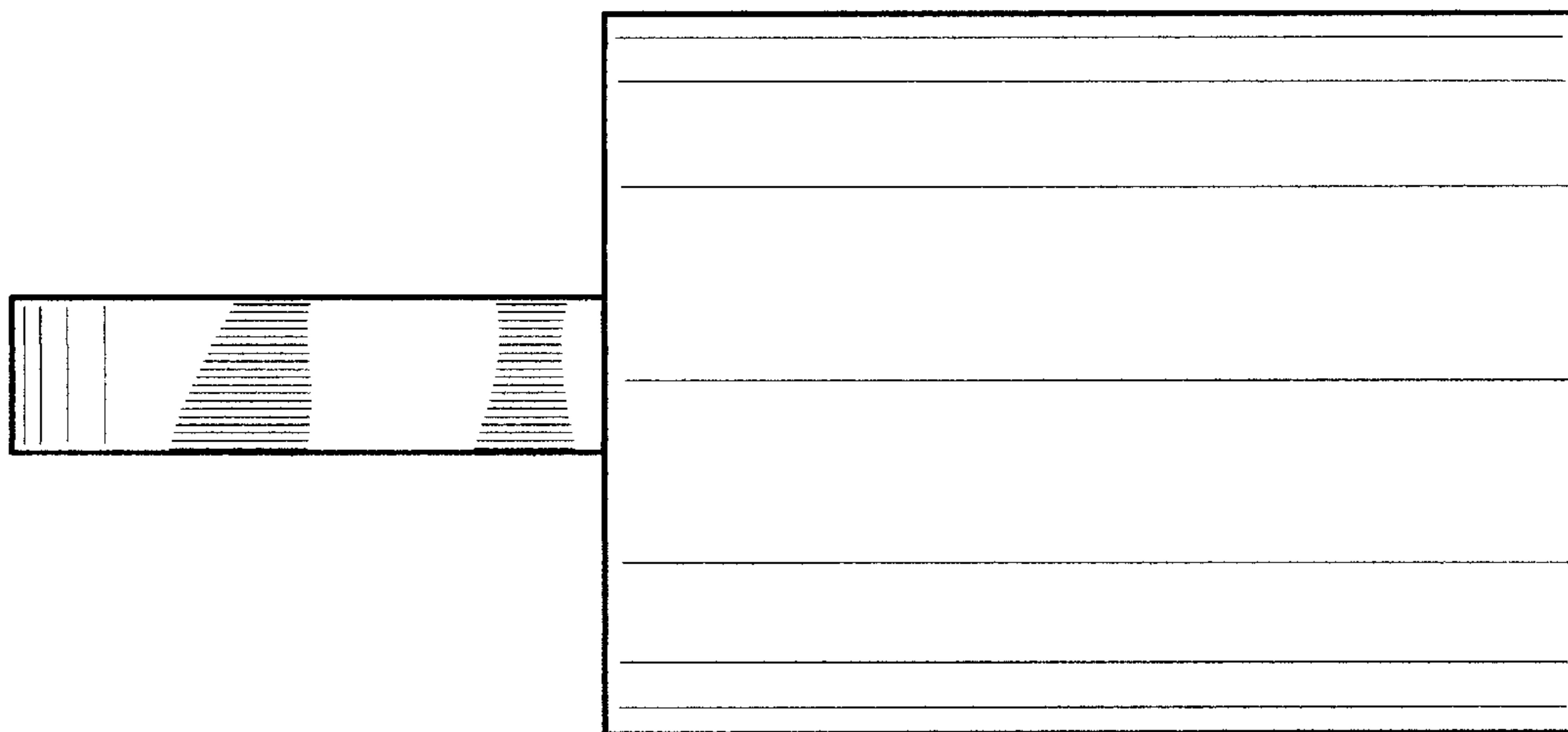

FIG. 2

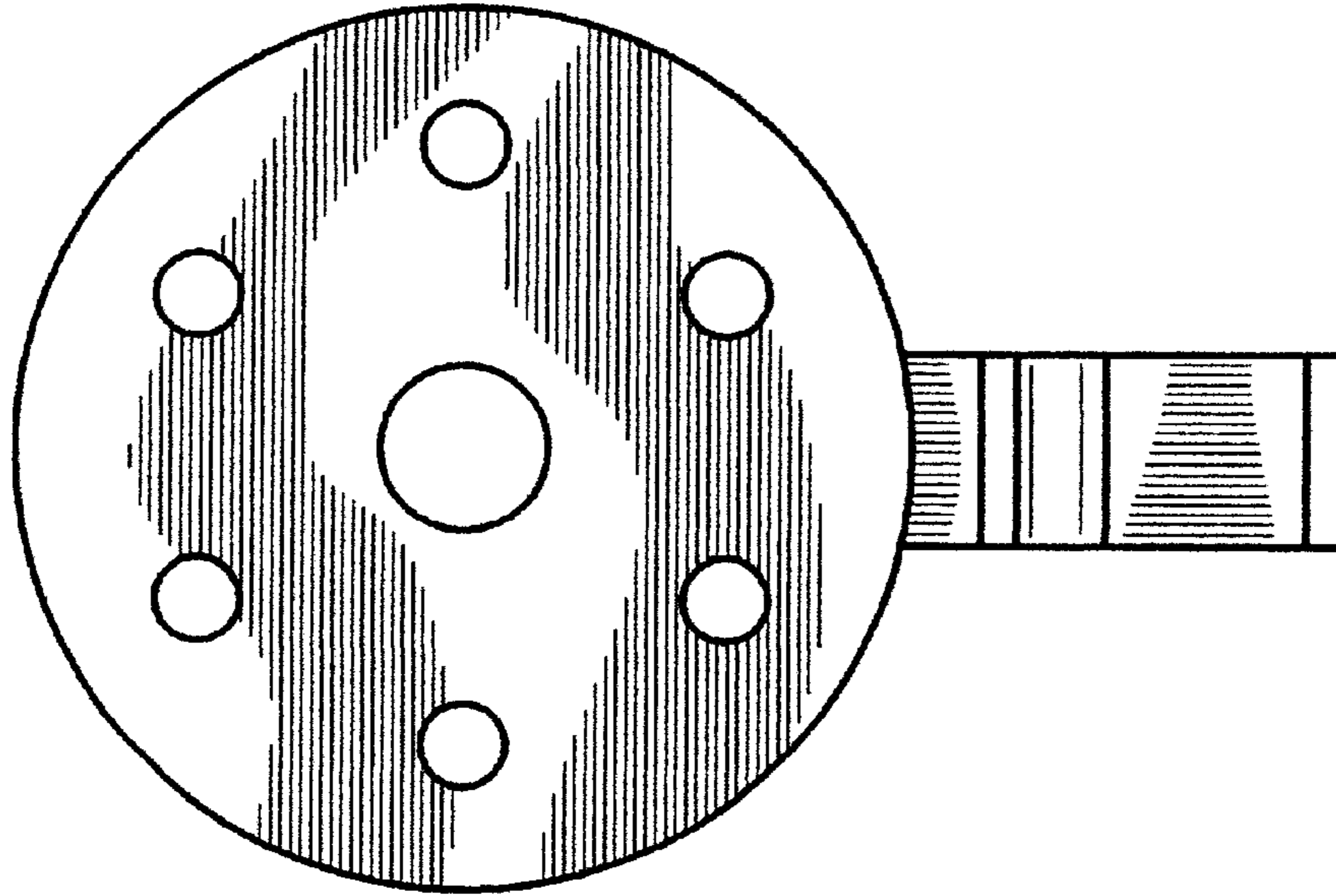

FIG. 5

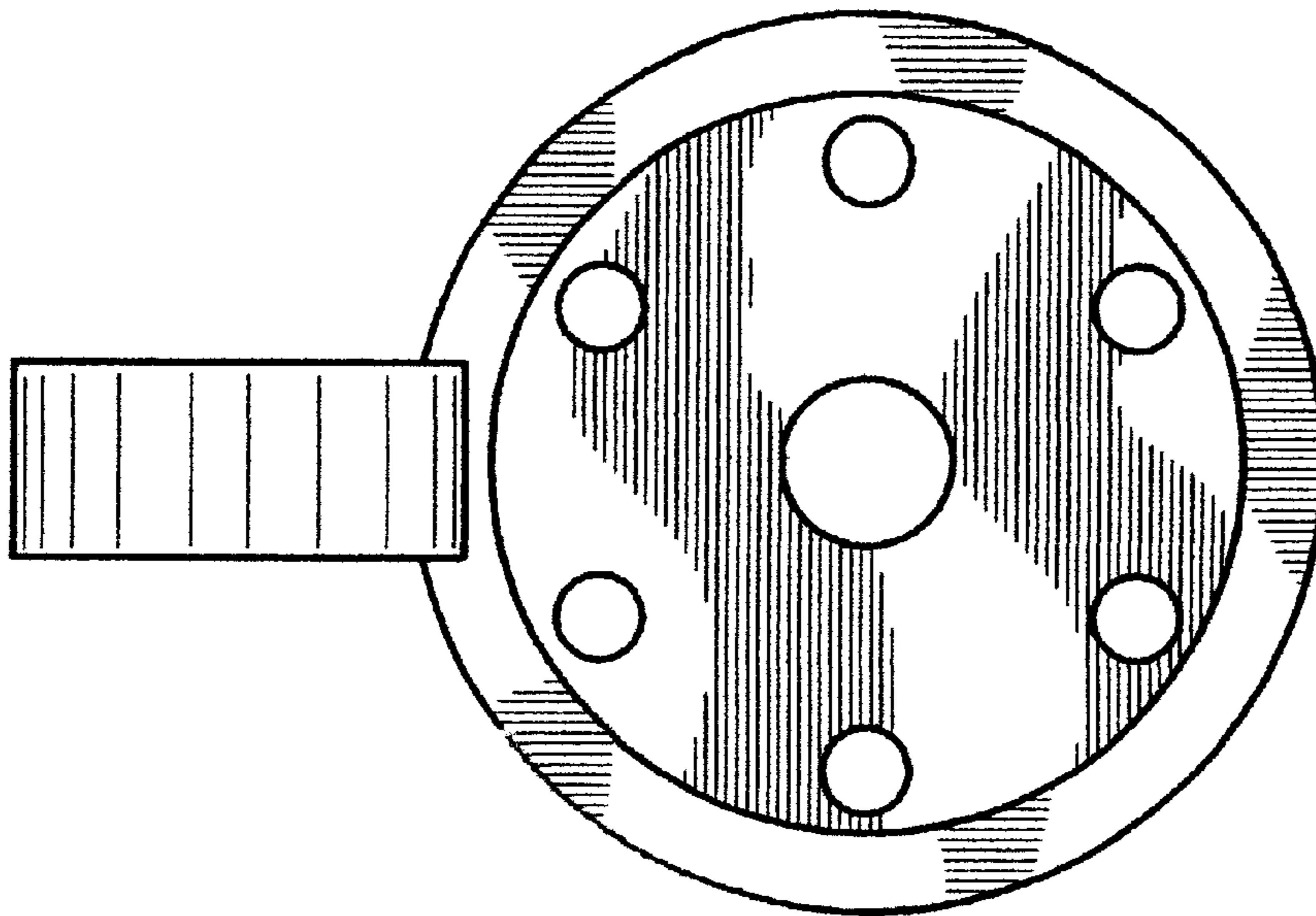

FIG. 4