

US00D511318S

(12) **United States Design Patent** (10) **Patent No.:** **US D511,318 S**
Sugimoto (45) **Date of Patent:** **** Nov. 8, 2005**

(54) **FOUR-WHEELED MOTORCYCLE**

(75) Inventor: **Yoshio Sugimoto**, Tokyo-to (JP)

(73) Assignee: **Yamaha Hatsudoki Kabushiki Kaisha**, Shizuoka-ken (JP)

(**) Term: **14 Years**

(21) Appl. No.: **29/194,197**

(22) Filed: **Nov. 20, 2003**

(30) **Foreign Application Priority Data**

Jun. 27, 2003 (JP) 2003-018424

(51) **LOC (8) Cl.** **12-11**

(52) **U.S. Cl.** **D12/107**

(58) **Field of Search** D12/87, 107; 180/225, 180/229, 233, 311, 312, 315

(56) **References Cited**

U.S. PATENT DOCUMENTS

D452,835 S * 1/2002 Aoki et al. D12/107

OTHER PUBLICATIONS

Staff of Dirt Wheels, *Dirt Wheels Magazine*, vol. 21, No. 2, Feb. 2001, pp. 40–44, “Performance Reports, Graydon Proline DS650 & Raptor 660R, More power and more excitement.”

Staff of Dirt Wheels, *Dirt Wheels Magazine*, vol. 21, No. 3, Mar. 2001, pp. 40, 41 and 43, “Sport Test, 2001 Honda Sportrax 250EX, An all–new, recreational quad.”

Staff of Dirt Wheels, *Dirt Wheels Magazine*, vol. 21, No. 4, Apr. 2001, pp. 52, 53 and 55–57, “Trail Evaluations, Easy–to–Ride Sport Quad Shootout, Honda Sportrax 250EX vs. Polaris Trail Blazer 250 vs. Kawasaki Lakota Sport 300.”

Staff of Dirt Wheels, *Dirt Wheels Magazine*, vol. 21, No. 6, Jun. 2001, pp. 70–72, “Exclusive First Look, 2002 VCR 530, The Ferrari of ATVing.”

Staff of Dirt Wheels, *Dirt Wheels Magazine*, vol. 21, No. 8, Aug. 2001, pp. 64–65, “New Models, 2002 Hondas, One new model with a promise of more to come.”

Staff of Dirt Wheels, *Dirt Wheels Magazine*, vol. 21, No. 9, Sep. 2001, pp. 69–70, “First Look, 2002 Suzukis, The father of four–wheeling makes a comeback.”

Staff of Dirt Wheels, *Dirt Wheels Magazine*, vol. 21, No. 9, Sep. 2001, p. 75, “First Look, 2002 Arctic Cats, Fifteen models including new autos and a tilt–bed.”

Staff of Dirt Wheels, *Dirt Wheels Magazine*, vol. 21, No. 11, Nov. 2001, pp. 46–47, “New Models, 2002 Polaris ATVs, The largest quad lineup in the ATV world.”

Staff of Dirt Wheels, *Dirt Wheels Magazine*, vol. 21, No. 12, Dec. 2001, pp. 52–53, “First Look, 2003 Suzuki QuadSport Z400, New high–performance quad & 2002 250 Ozark sport/utility.”

Staff of Dirt Wheels, *Dirt Wheels Magazine*, vol. 21, No. 12, Dec. 2001, p. 78, “New Models, 2002 Kasea Line–Up, More fun machines, including a 250 Twin sport quad.”

Staff of Dirt Wheels, *Dirt Wheels Magazine*, vol. 21, No. 12, Dec. 2001, pp. 152–153, 155–156 and 158, “High Performance Test, 2002 Yamaha Raptor 660, Changes for its sophomore year.”

(Continued)

Primary Examiner—Alan P. Douglas

Assistant Examiner—Linda Brooks

(74) *Attorney, Agent, or Firm*—Knobbe, Martens, Olson & Bear, LLP

(57) **CLAIM**

The ornamental design for a four-wheeled motorcycle, as shown and described.

DESCRIPTION

FIG. 1 is a perspective view of the a four-wheeled motorcycle configured in accordance with a preferred embodiment of the present invention;

FIG. 2 is a right side elevational view thereof;

FIG. 3 is a left side elevational view thereof;

FIG. 4 is a front elevational view thereof;

FIG. 5 is a rear view thereof;

FIG. 6 is a top elevational view thereof; and,

FIG. 7 is a bottom elevational view thereof.

1 Claim, 7 Drawing Sheets

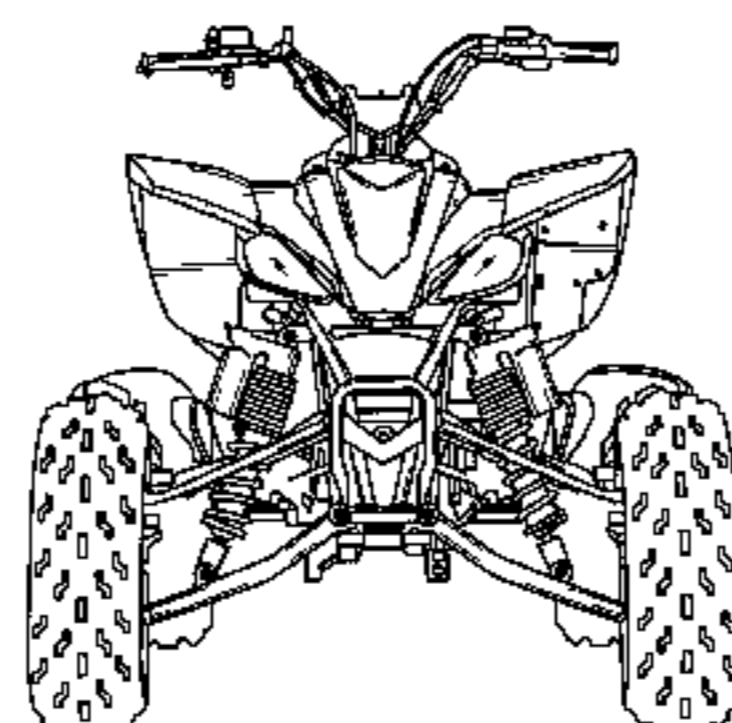
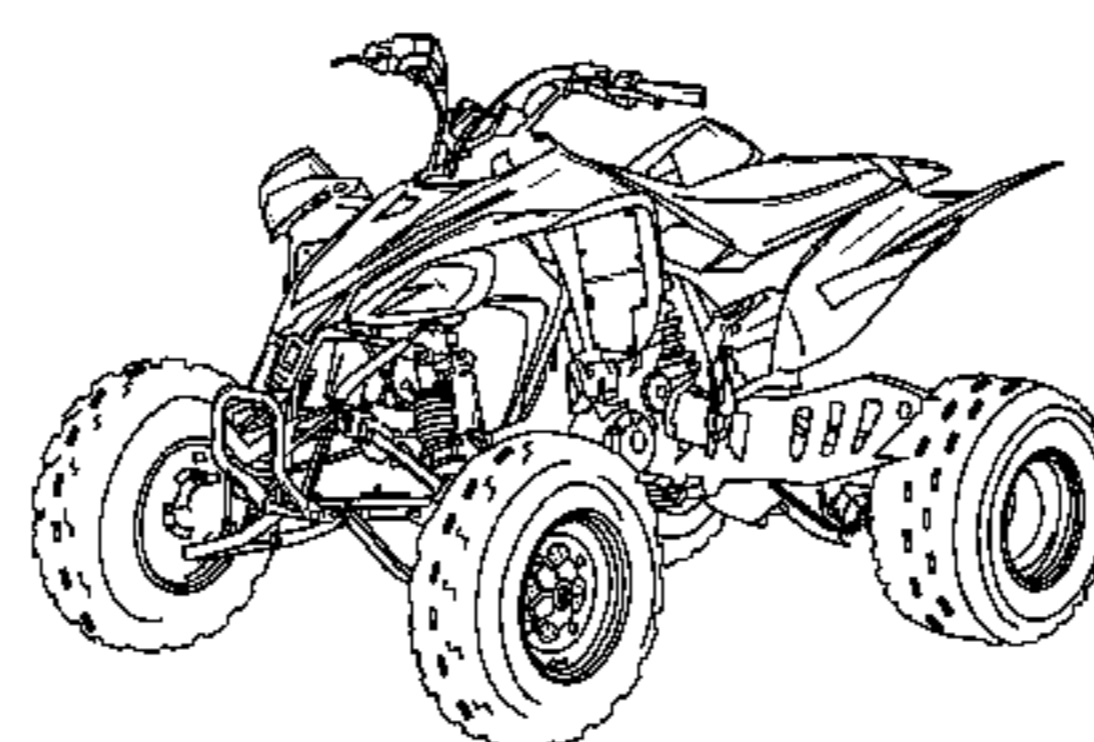

OTHER PUBLICATIONS

- Staff of Dirt Wheels, *Dirt Wheels Magazine*, vol. 22, No. 1, Jan. 2002, pp. 110–112 and 119–120, “Special Section, 2002 Buyer’s Guide, Photos, info & specs on every ATV.”
- Staff of Dirt Wheels, *Dirt Wheels Magazine*, vol. 22, No. 8, Aug. 2002, pp. 70–71, “First Look, 2003 Yamahas, New Kodiak 450, revamped Blaster and 12 returning models.”
- Staff of Dirt Wheels, *Dirt Wheels Magazine*, vol. 22, No. 9, Sep. 2002, pp. 68–69, “First Look, 2003 Kawasakis, A hot new high–performance 400 and two new minis.”
- Staff of Dirt Wheels, *Dirt Wheels Magazine*, vol. 22, No. 9, Sep. 2002, pp. 70–71 and 77, “First Look, 2003 Hondas, Big Red rolls out its 15–quad stable.”
- Staff of Dirt Wheels, *Dirt Wheels Magazine*, vol. 22, No. 9, Sep. 2002, pp. 80–81, “New Models, 2003 Bombardiers, Bombardier expands their lineup.”
- Staff of Dirt Wheels, *Dirt Wheels Magazine*, vol. 22, No. 10, Oct. 2002, pp. 48–50 and 52, “High Performance Test, 2003 Polaris Predator 500, Is this the best Polaris ever?”
- Staff of Dirt Wheels, *Dirt Wheels Magazine*, vol. 22, No. 12, Dec. 2002, pp. 84–86 and 88, “First Look, 2004 Kawasaki KFX 700 V–Force, Radical V–Twin powered sport quad.”
- Staff of Dirt Wheels, *Dirt Wheels Magazine*, vol. 23, No. 1, Jan. 2003, pp. 48–50, 52 and 54, “High Performance Test, 2003 Kawasaki KFX 400, The Green one.”
- Staff of Dirt Wheels, *Dirt Wheels Magazine*, vol. 23, No. 1, Jan. 2003, pp. 68–70 and 72, “First Look, 2004 Kawasaki KFX700 V–Force, Full Race IMS/Roll Design.”
- Staff of Dirt Wheels, *Dirt Wheels Magazine*, vol. 23, No. 1, Jan. 2003, pp. 76–78, “First Look, 2004 Suzuki QuadSport Z–250, Entry–level fun machine.”
- Staff of Dirt Wheels, *Dirt Wheels Magazine*, vol. 23, No. 1, Jan. 2003, pp. 115–118 and 123–124, “Special Section, 2003 ATV Buyer’s Guide, The full mead deal on every ATV.”
- Staff of Dirt Wheels, *Dirt Wheels Magazine*, vol. 23, No. 1, Jan. 2003, pp. 148–150, “Mini Test, 2003 E–Ton Viper 90, E–Ton’s new model.”
- Staff of Dirt Wheels, *Dirt Wheels Magazine*, vol. 23, No. 7, Jul. 2003, pp. 65–67, “Sport Test, 2004 Suzuki Z–250, Another Suzuki hit.”
- Staff of Dirt Wheels, *Dirt Wheels Magazine*, vol. 23, No. 8, Aug. 2003, pp. 36–42, “First Look, 2004 Yamaha YFZ450, A new high–performance standard.”
- Staff of Dirt Wheels, *Dirt Wheels Magazine*, vol. 23, No. 8, Aug. 2003, pp. 46–48, “First Look, 2004 Yamaha ATVs, Nine sport and entry–level quads with more yet to come”
- Staff of Dirt Wheels, *Dirt Wheels Magazine*, vol. 23, No. 8, Aug. 2003, pp. 94–96, “Mini Test, 2003 Polaris Predator 90, American mini?”
- Staff of Dirt Wheels, *Dirt Wheels Magazine*, vol. 23, No. 9, Sep. 2003, pp. 38–40, “First Look, 2004 Arctic Cats, New DVX Sport Quad & 650 V–twin take center stage.”
- Staff of Dirt Wheels, *Dirt Wheels Magazine*, vol. 23, No. 9, Sep. 2003, pp. 46–48, “First Look, 2004 Suzukis, Keeping a good thing going.”
- Staff of Dirt Wheels, *Dirt Wheels Magazine*, vol. 23, No. 9, Sep. 2003, pp. 52–54, “First Look, 2004 Kawasakis, Less models but the Prairie gets a boost.”
- Staff of Dirt Wheels, *Dirt Wheels Magazine*, vol. 23, No. 10, Oct. 2003, p. 38, “2004 Hondas.”
- Staff of Dirt Wheels, *Dirt Wheels Magazine*, vol. 23, No. 10, Oct. 2003, pp. 40–44, “First Test, 2004 Arctic Cat DVX400, A cool cat with claws and personality.”
- Staff of Dirt Wheels, *Dirt Wheels Magazine*, vol. 23, No. 11, Nov. 2003, pp. 40–43, “First Look, 2004 Honda Sportrax TRX450R, Finally, the next generation Honda Sport ATV has arrived.”
- Staff of Dirt Wheels, *Dirt Wheels Magazine*, vol. 23, No. 11, Nov. 2003, pp. 64–65, “First Look, 2004 Polaris Lineup, New Mossy Oak models for 2004.”
- Polaris 2001 Catalog of ATVs, Off–Road Vehicles, Parts, Apparel and Accessories*, pp. 17 and 30–31.
- Yamaha 2001 Catalog of Sports ATVs*, pp. 2–4.
- Sugimoto, Yoshio, *Front Fender For Four–Wheeled Motorcycle*, U.S. Appl. No. 29/194,198, filed Nov. 20, 2003.
- Sugimoto, Yoshio, *Side Cover for a Four–Wheeled Motorcycle*, U.S. Appl. No. 29/194,196, filed Nov. 20, 2003.

* cited by examiner

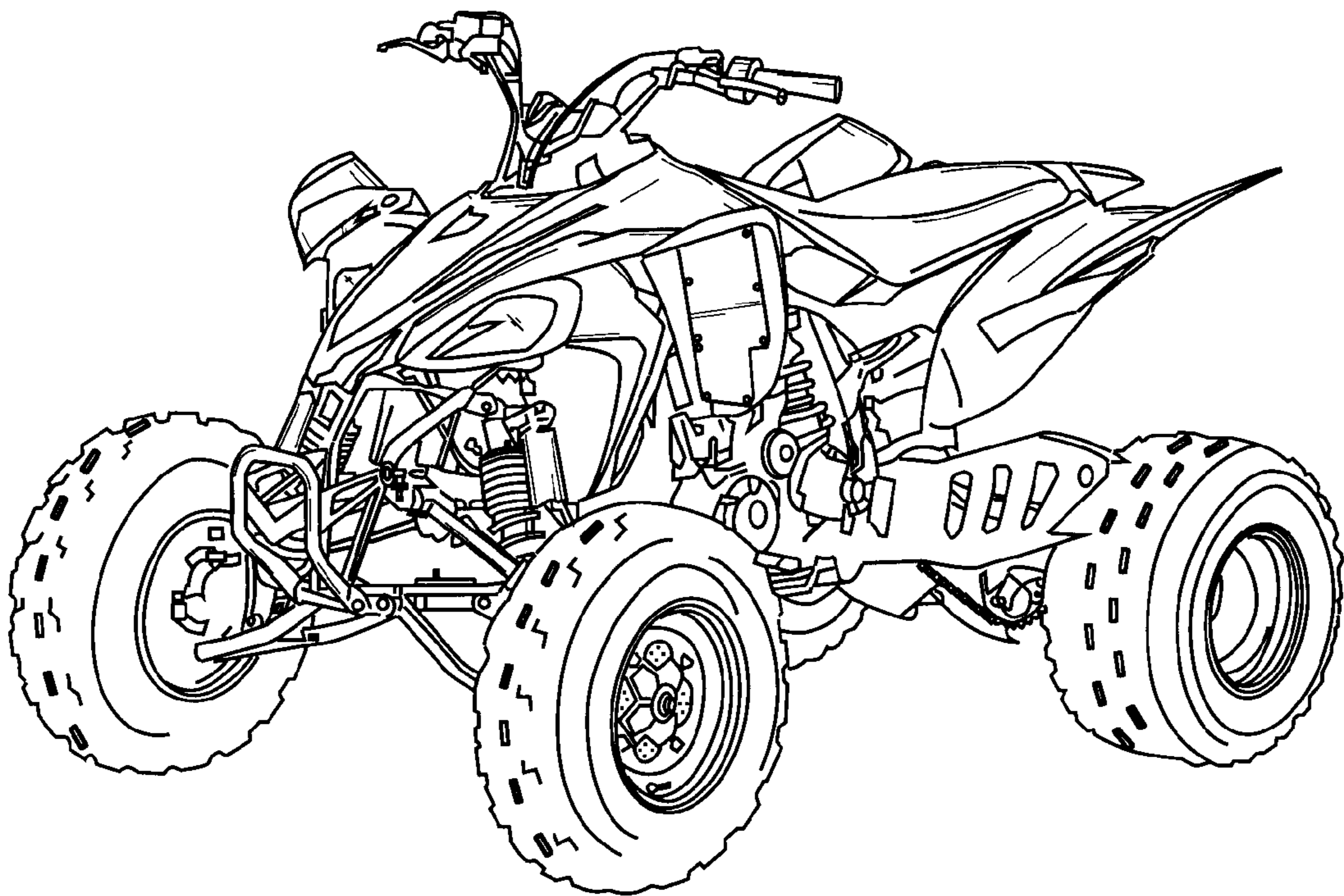

Figure 1

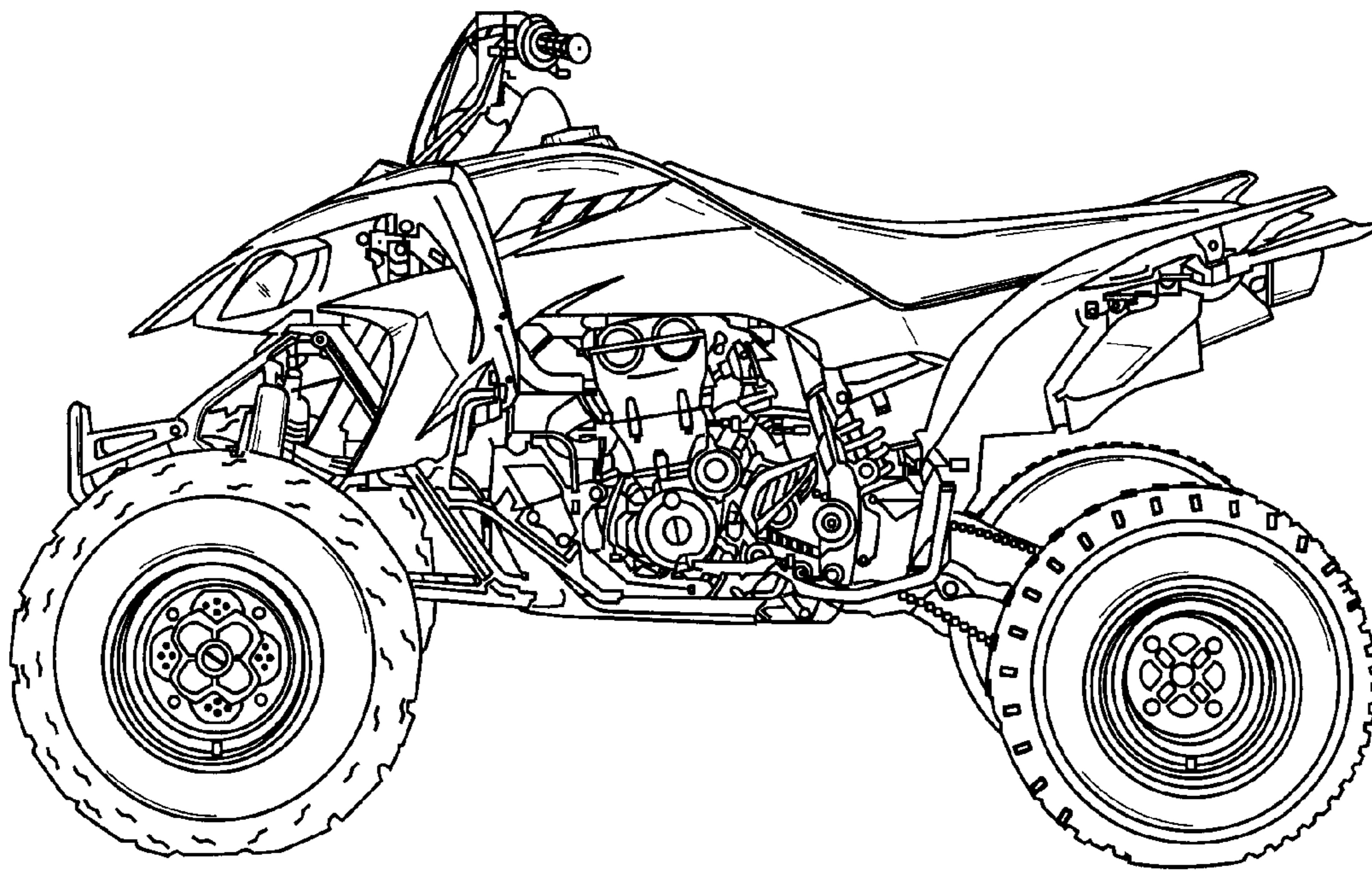

Figure 2

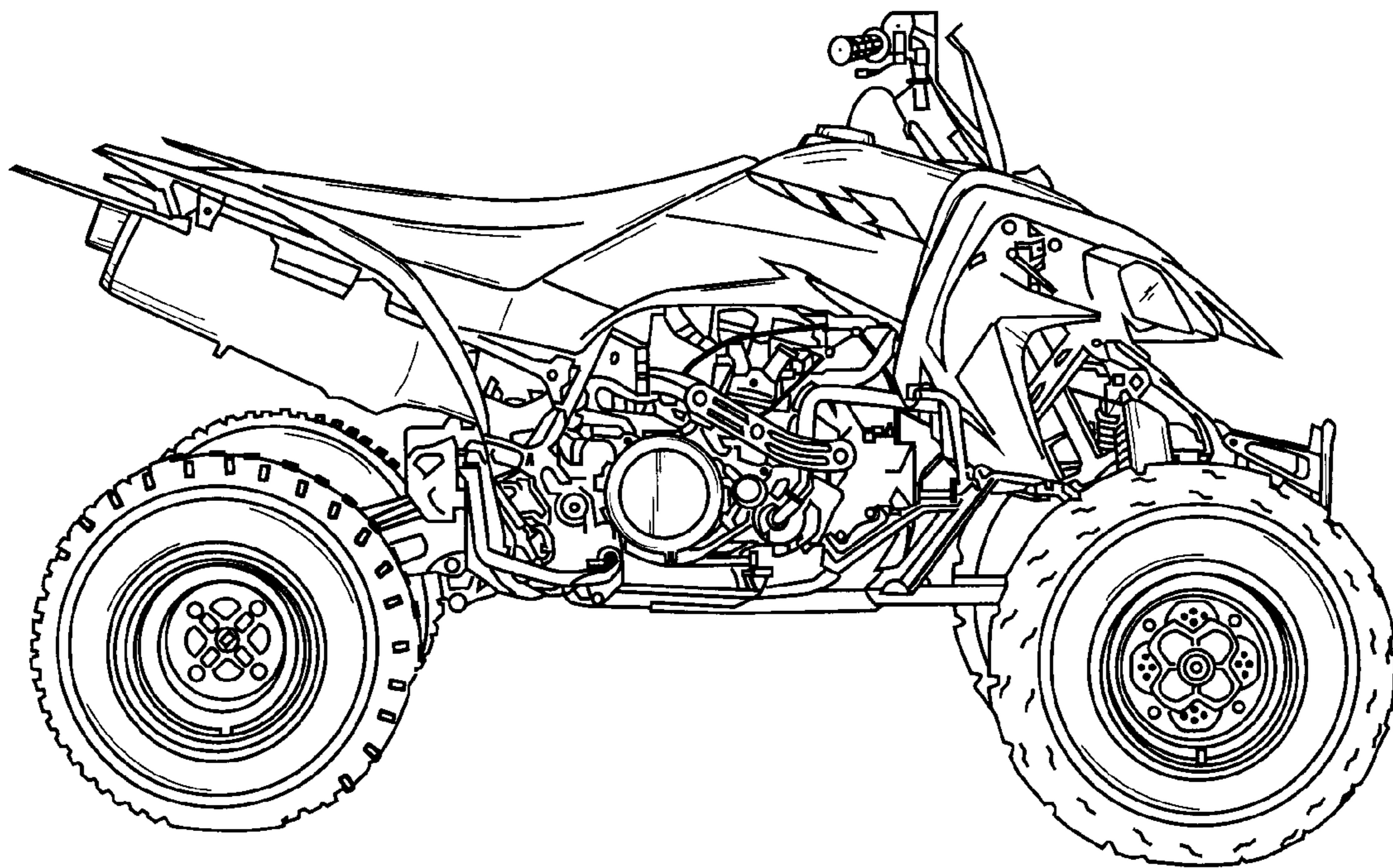

Figure 3

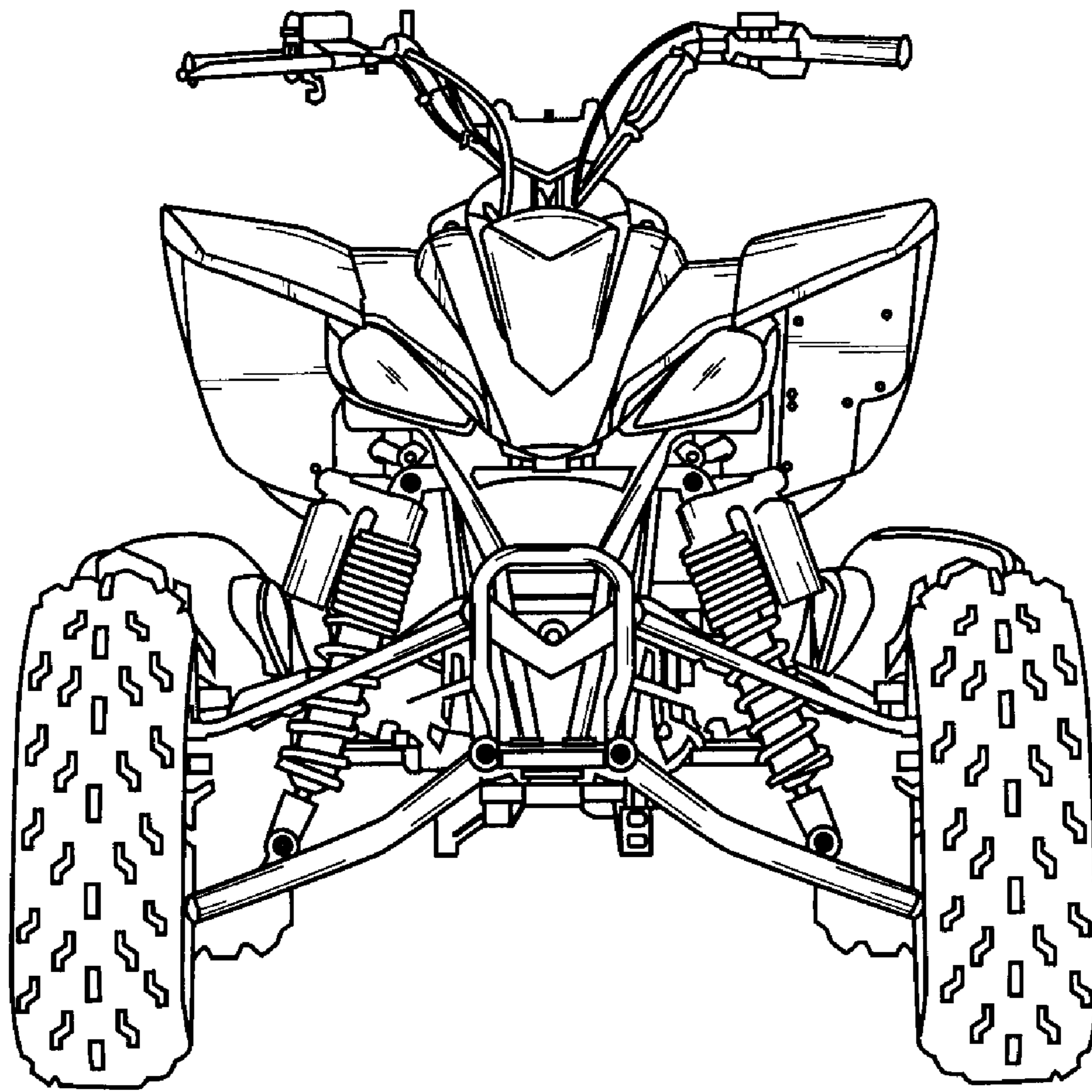

Figure 4

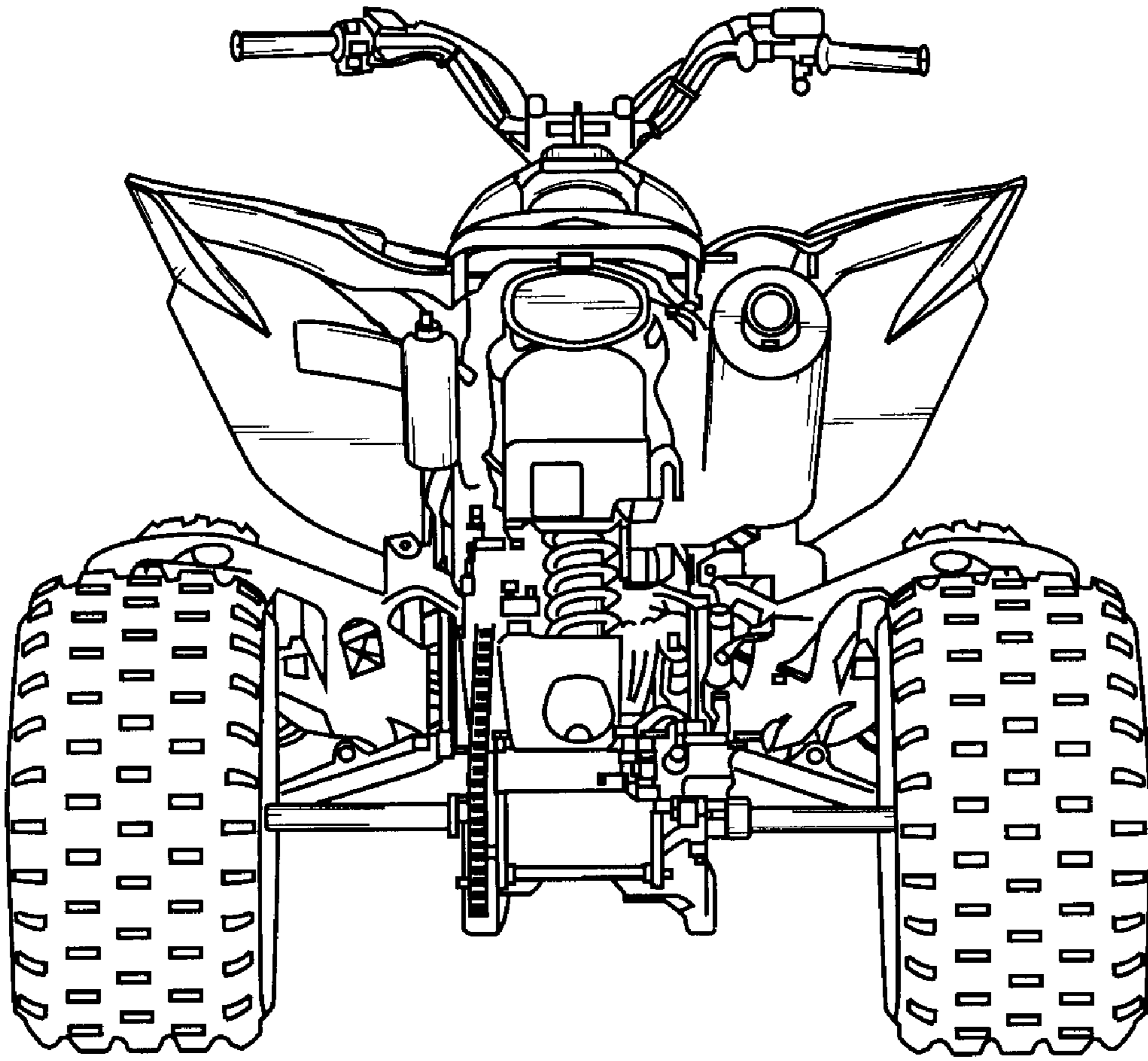

Figure 5

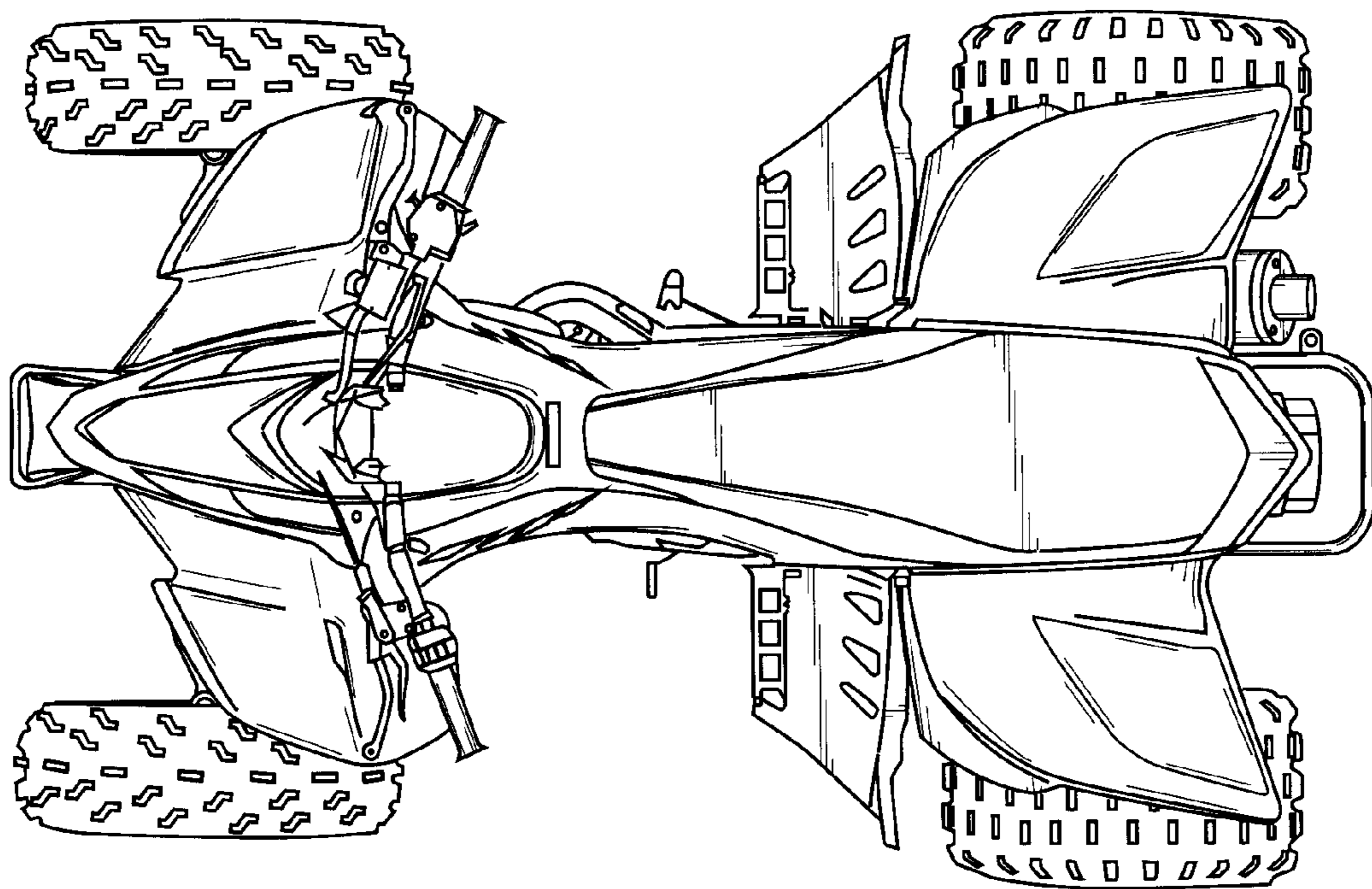

Figure 6

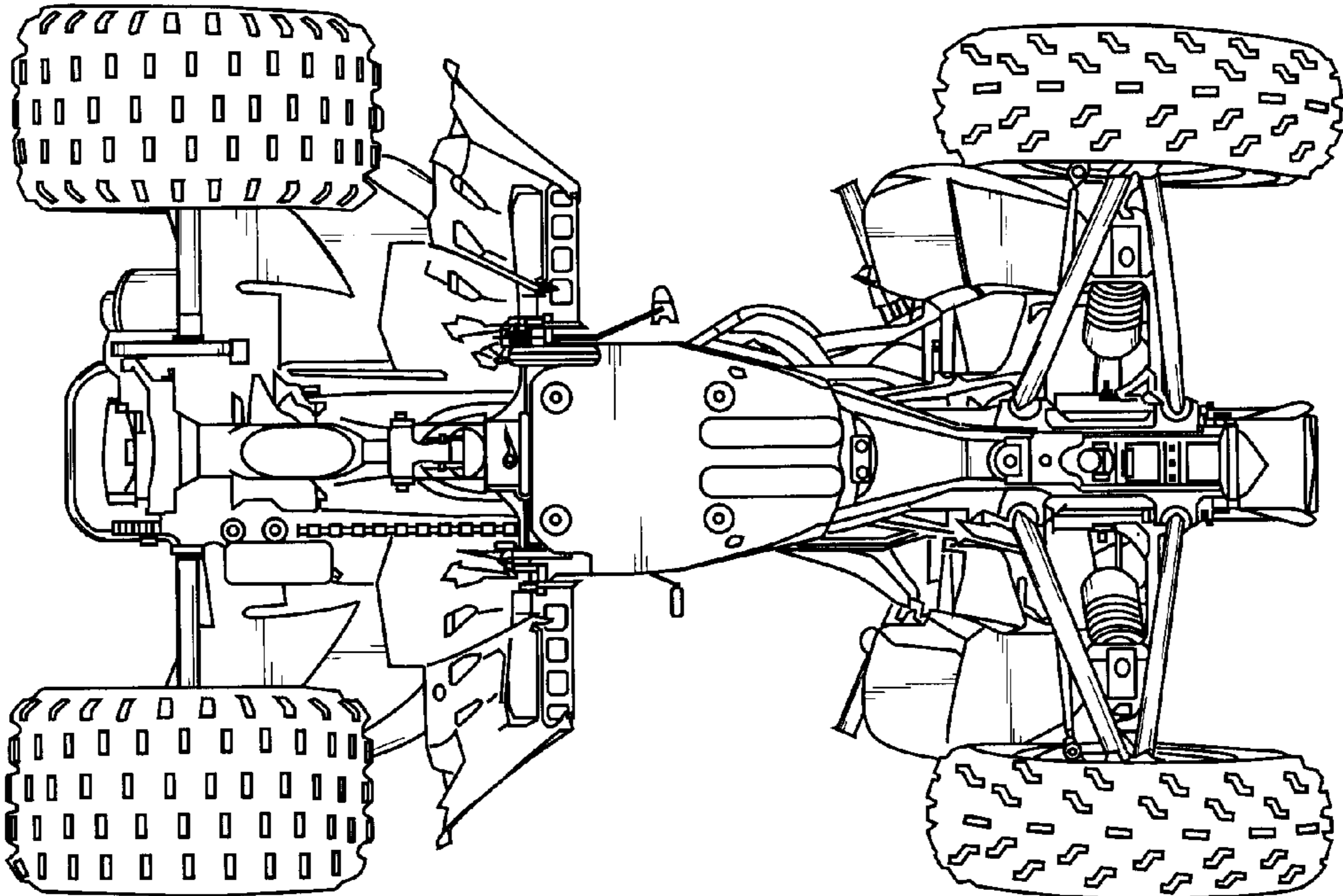

Figure 7