



US00D511175S

(12) **United States Design Patent**  
**Staines et al.**

(10) **Patent No.: US D511,175 S**

(45) **Date of Patent: \*\* Nov. 1, 2005**

(54) **ENGINE ENCLOSURE STYLING**

D427,205 S \* 6/2000 Shimizu ..... D15/23  
D466,531 S \* 12/2002 Hohnl et al. .... D15/31  
D483,383 S \* 12/2003 Crookes et al. .... D15/31  
D497,370 S \* 10/2004 Katoh ..... D15/31

(75) Inventors: **Douglas Larry Staines**, Waverly, IA (US); **Brian Timothy Brown**, Waterloo, IA (US); **Aris G. Nichols**, Grosse Pointe City, MI (US)

\* cited by examiner

(73) Assignee: **Deere & Company**, Moline, IL (US)

*Primary Examiner*—Stella M. Reid  
*Assistant Examiner*—Mark A. Goodwin

(\*\*) Term: **14 Years**

(57) **CLAIM**

(21) Appl. No.: **29/218,988**

The ornamental design for an engine enclosure styling, as shown and described.

(22) Filed: **Dec. 10, 2004**

(51) **LOC (8) Cl.** ..... **15-03**

(52) **U.S. Cl.** ..... **D15/31**

(58) **Field of Search** ..... D15/31, 10, 11,  
D15/15, 17, 28, 22-26; D12/173; D25/142,  
156, 47; 180/89.1, 89.12, 900, 68.1, 69.1,  
69.2

**DESCRIPTION**

FIG. 1 is a perspective view of an engine enclosure styling showing our new design.

FIG. 2 is a front view thereof;

FIG. 3 is a top view thereof;

FIG. 4 is a right side view thereof; and,

FIG. 5 is a left side view thereof.

(56) **References Cited**

**U.S. PATENT DOCUMENTS**

D354,756 S \* 1/1995 Hinklin ..... D15/15

**1 Claim, 5 Drawing Sheets**

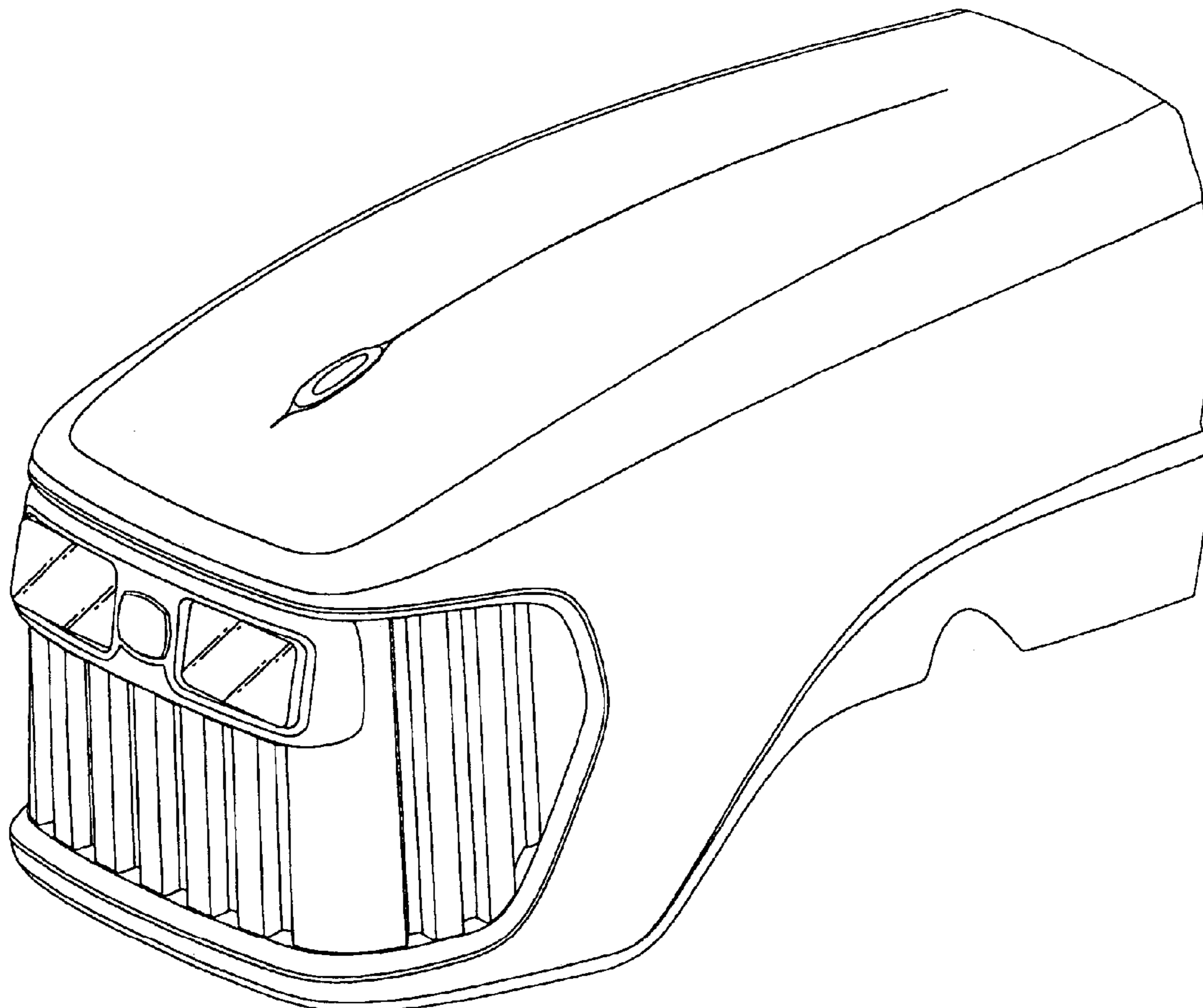

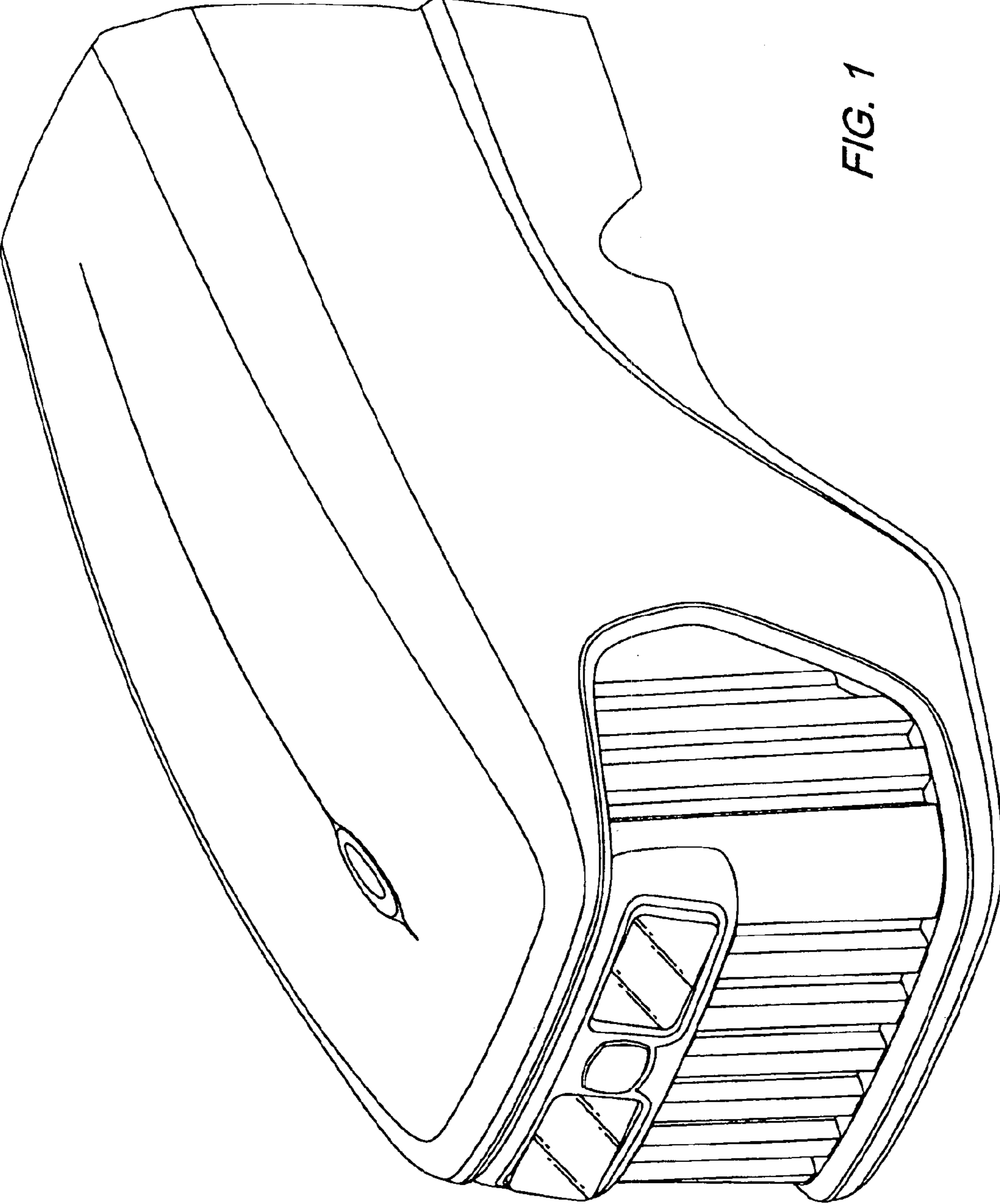

FIG. 1

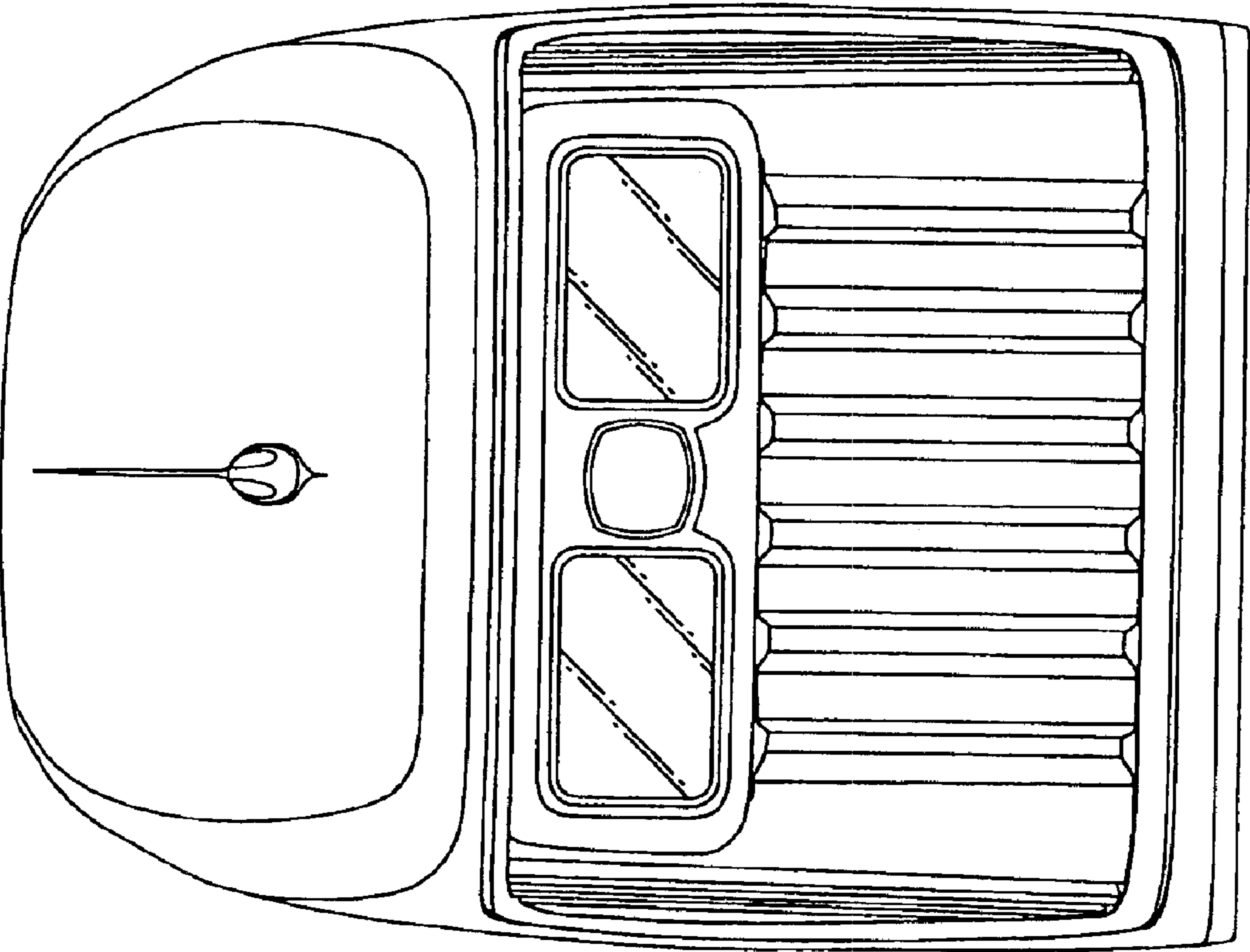

FIG. 2

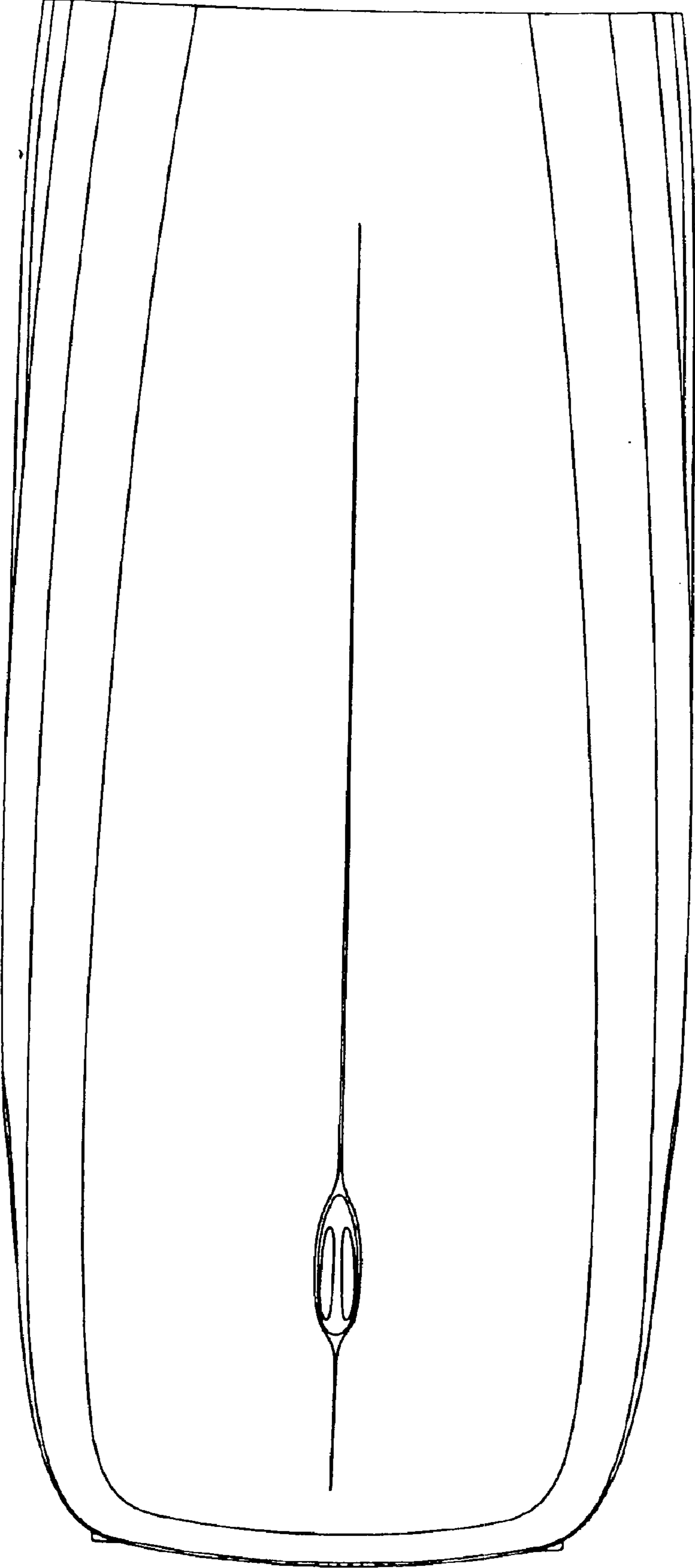

FIG. 3

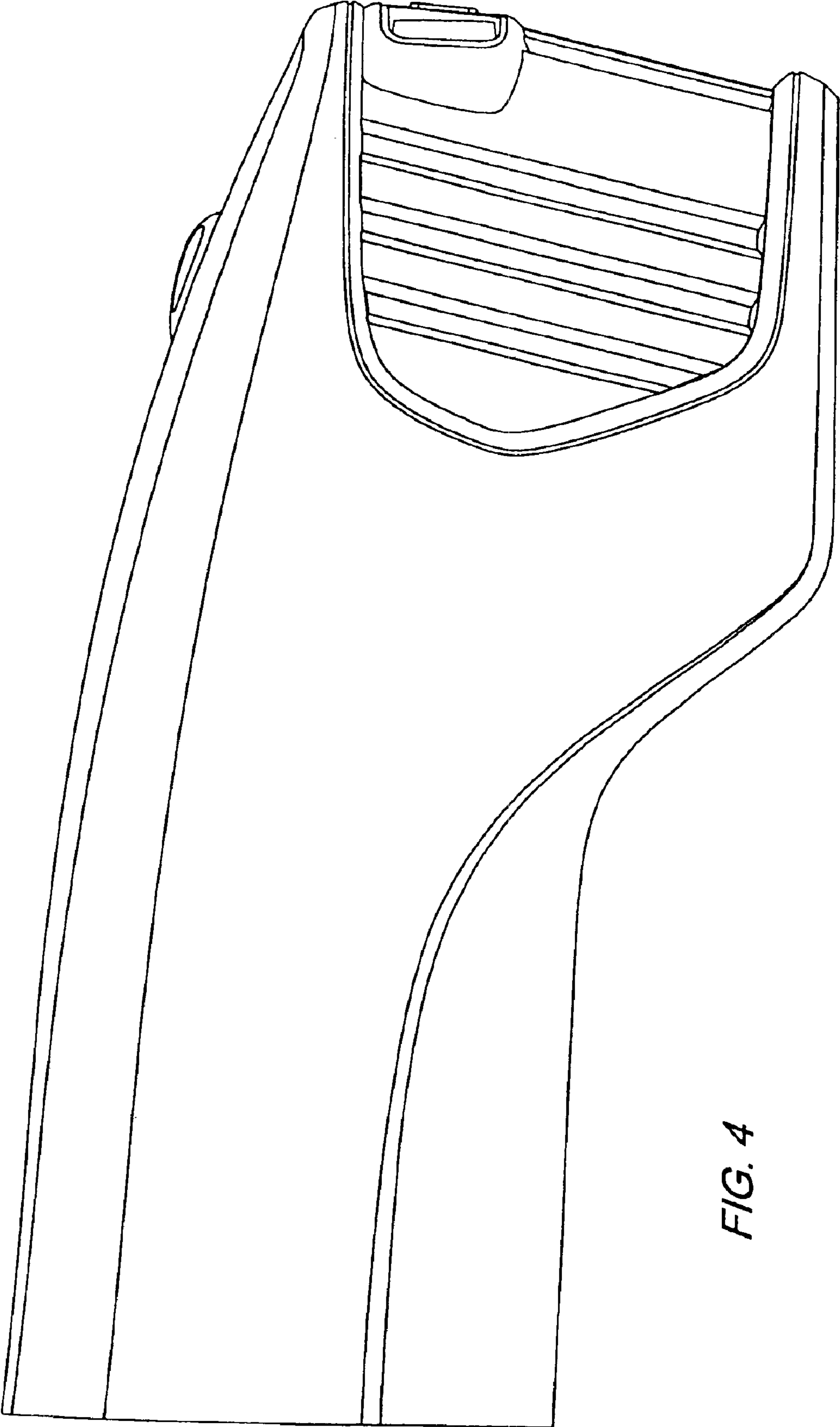

FIG. 4

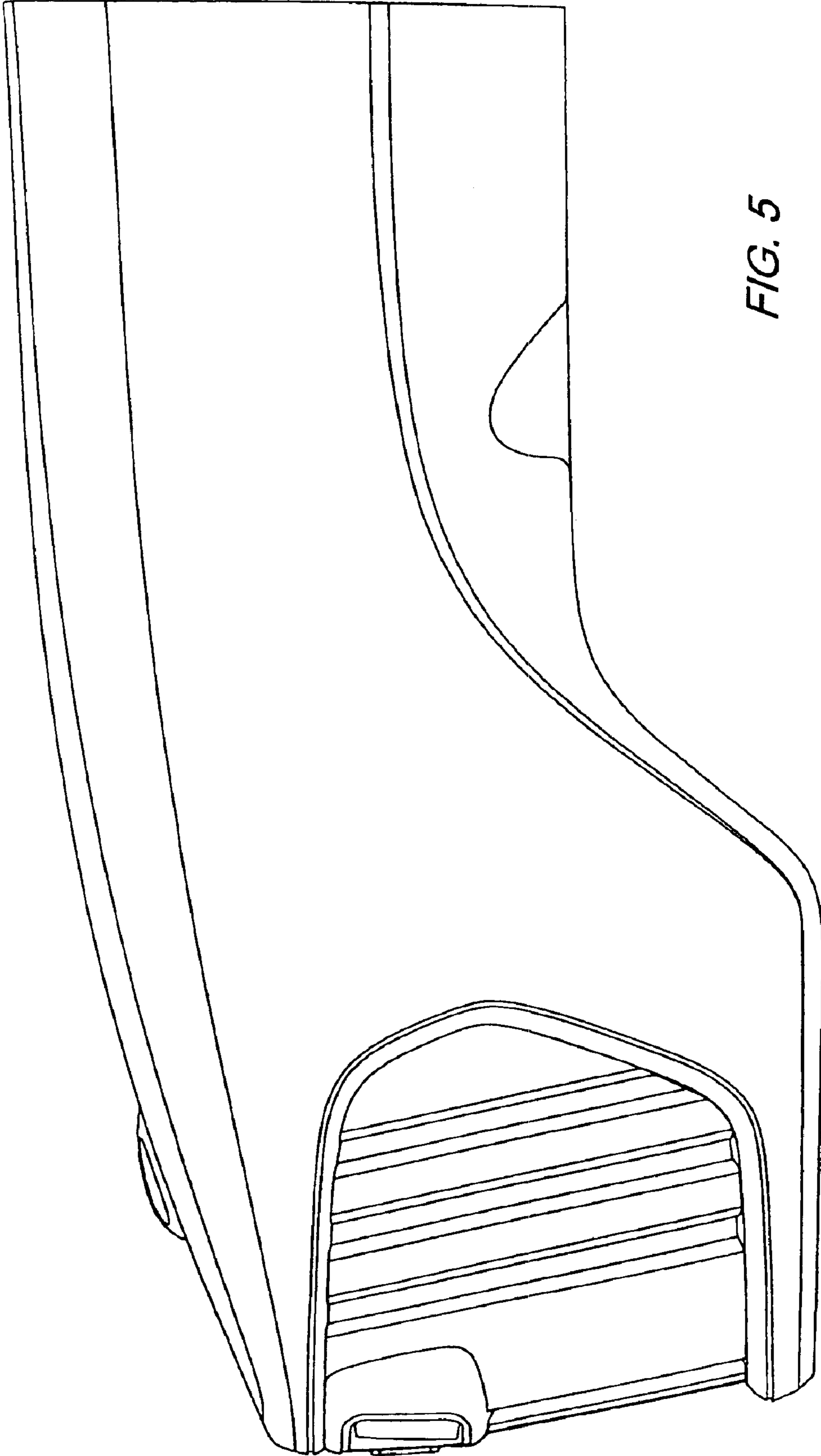

FIG. 5