



US00D511129S

(12) **United States Design Patent**
Nagashima

(10) **Patent No.:** **US D511,129 S**
(45) **Date of Patent:** **** Nov. 1, 2005**

(54) **SURFACE CONFIGURATION OF A SIDE DOOR FOR A VEHICLE**

(75) Inventor: **Joji Nagashima**, Munich (DE)

(73) Assignee: **Bayerische Motoren Werke Aktiengesellschaft**, Munich (DE)

(**) Term: **14 Years**

(21) Appl. No.: **29/217,895**

(22) Filed: **Nov. 24, 2004**

(30) **Foreign Application Priority Data**

May 27, 2004 (DE) 4 04 03 323

(51) **LOC (8) Cl.** **12-16**

(52) **U.S. Cl.** **D12/196**

(58) **Field of Search** D12/196, 86, 90-92;
296/185

(56) **References Cited**

U.S. PATENT DOCUMENTS

D418,471 S * 1/2000 Gabath D12/196

D467,849 S * 12/2002 Murkett D12/196

D479,170 S * 9/2003 Boyer D12/196

D491,860 S * 6/2004 Velazco D12/196

* cited by examiner

Primary Examiner—Melody N. Brown

(74) *Attorney, Agent, or Firm*—Crowell & Moring LLP

(57) **CLAIM**

The ornamental design for a surface configuration of a side door for a vehicle, as shown and described.

DESCRIPTION

This application is related to co-pending Application Ser. No. 29/217,910, of the inventor, filed on even date herewith and entitled "Surface Configuration of a Vehicle, Toy and/or Other Replicas".

FIG. 1 is a perspective view of a first embodiment of a surface configuration of a side door for a vehicle according to my novel design;

FIG. 2 is a side view of the first embodiment of the surface configuration of a side door for a vehicle according to my novel design;

FIG. 3 is a front view of the first embodiment of the surface configuration of a side door for a vehicle according to my novel design;

FIG. 4 is a perspective view of a second embodiment of the surface configuration of a side door for a vehicle according to my novel design;

FIG. 5 is a side view of the second embodiment of the surface configuration of a side door for a vehicle according to my novel design; and,

FIG. 6 is a front view of the second embodiment of the surface configuration of a side door for a vehicle according to my novel design.

The broken lines are for illustrative purposes only and form no part of the claimed design.

1 Claim, 2 Drawing Sheets

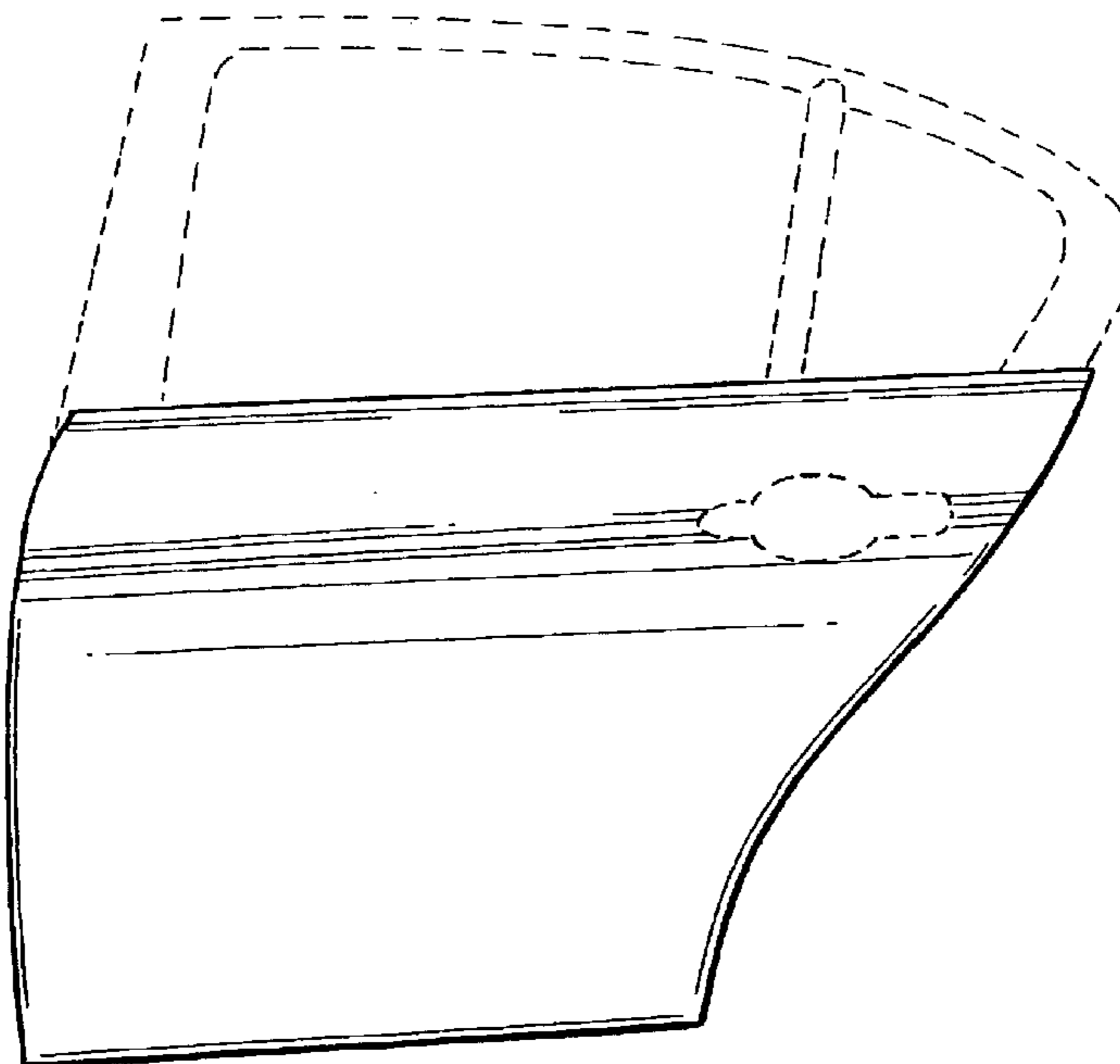

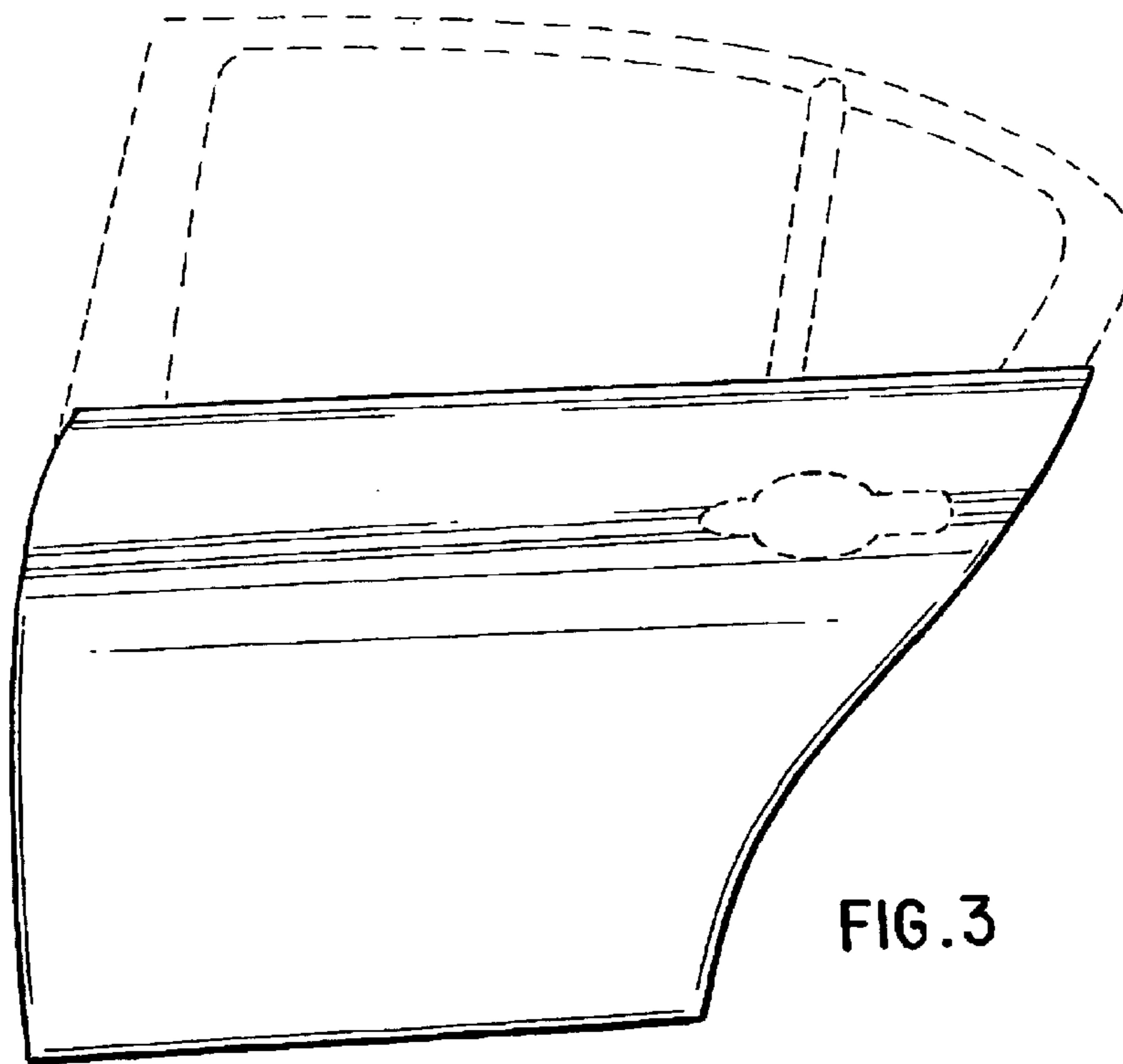
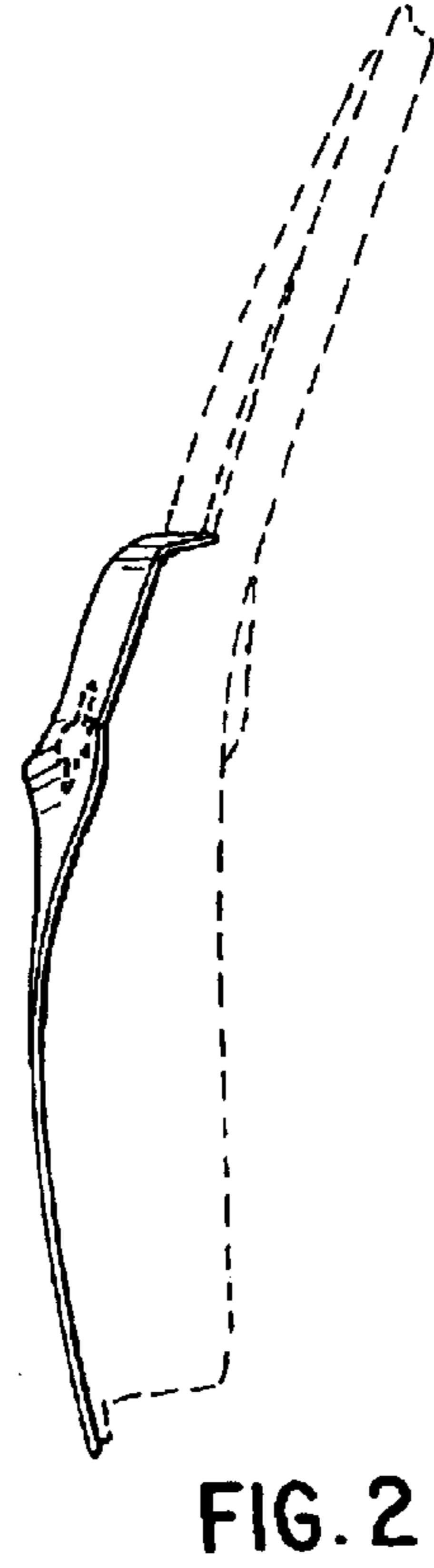
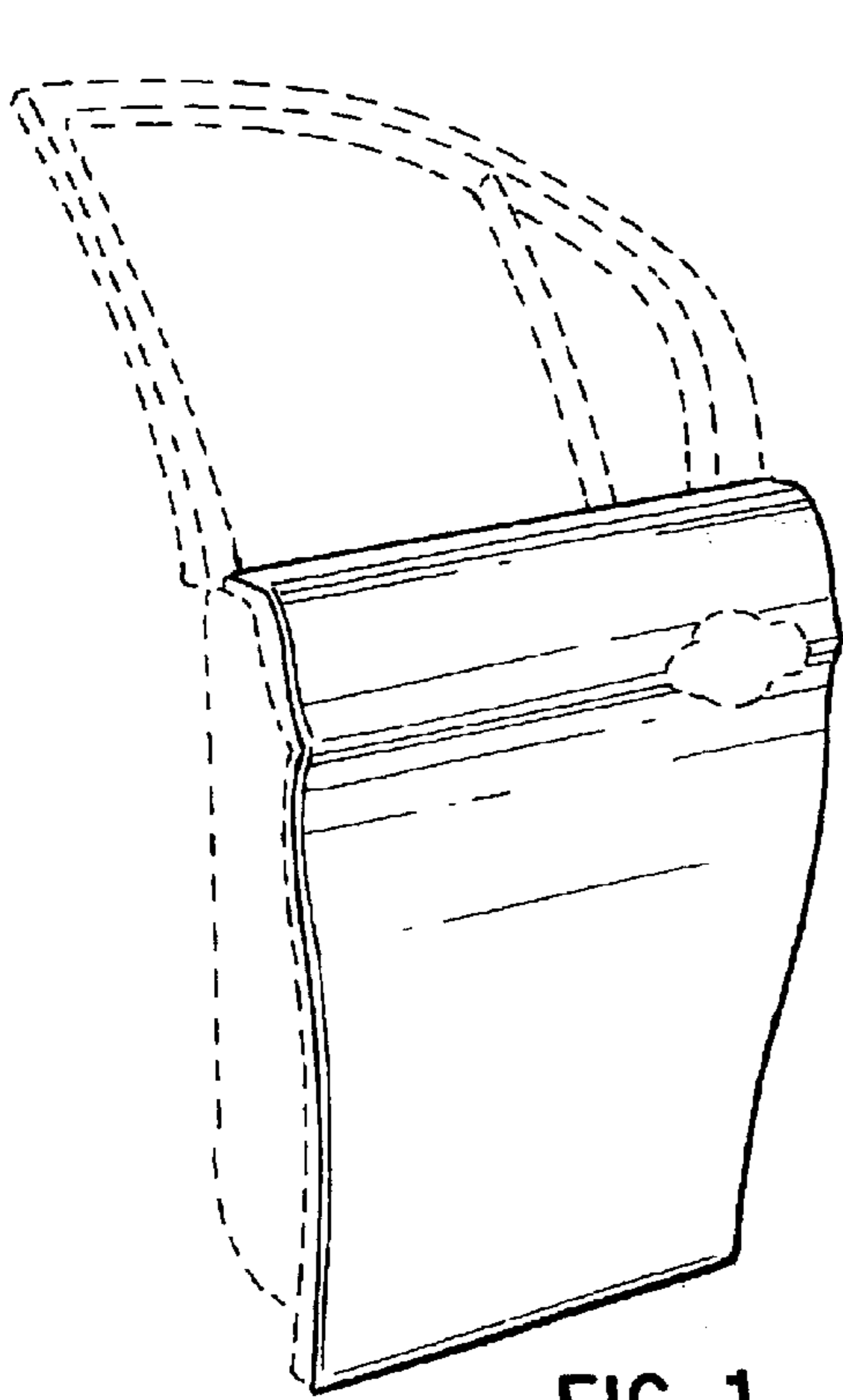

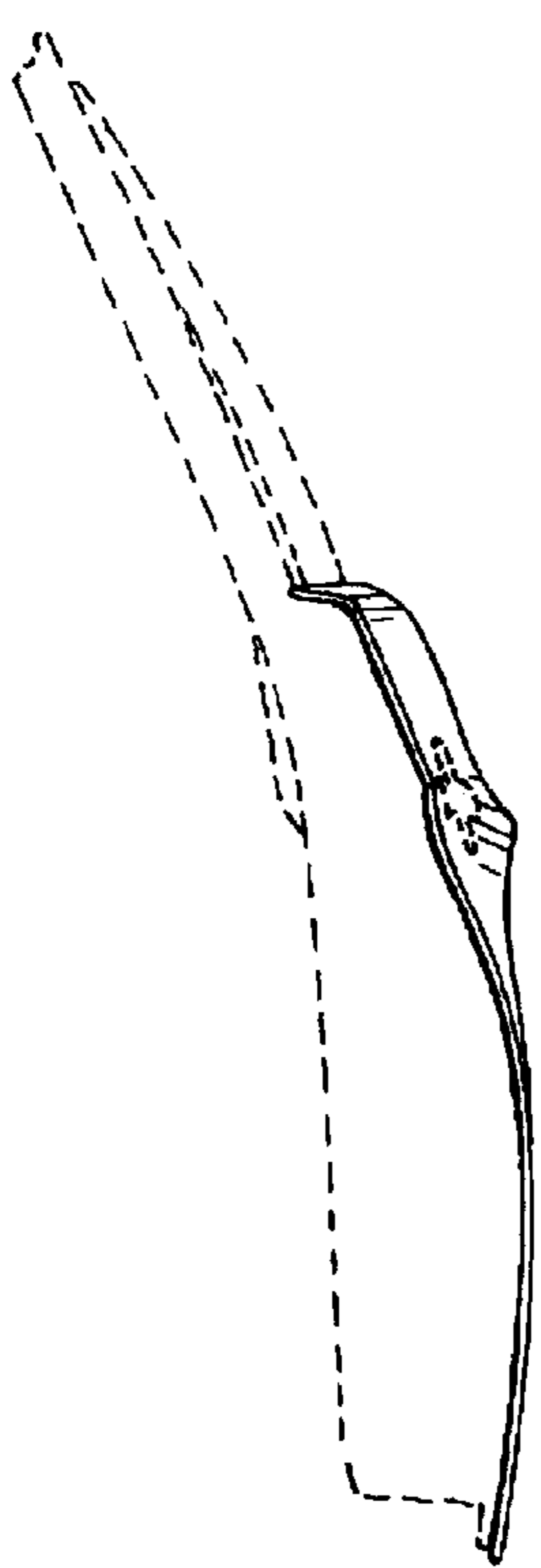

FIG. 5

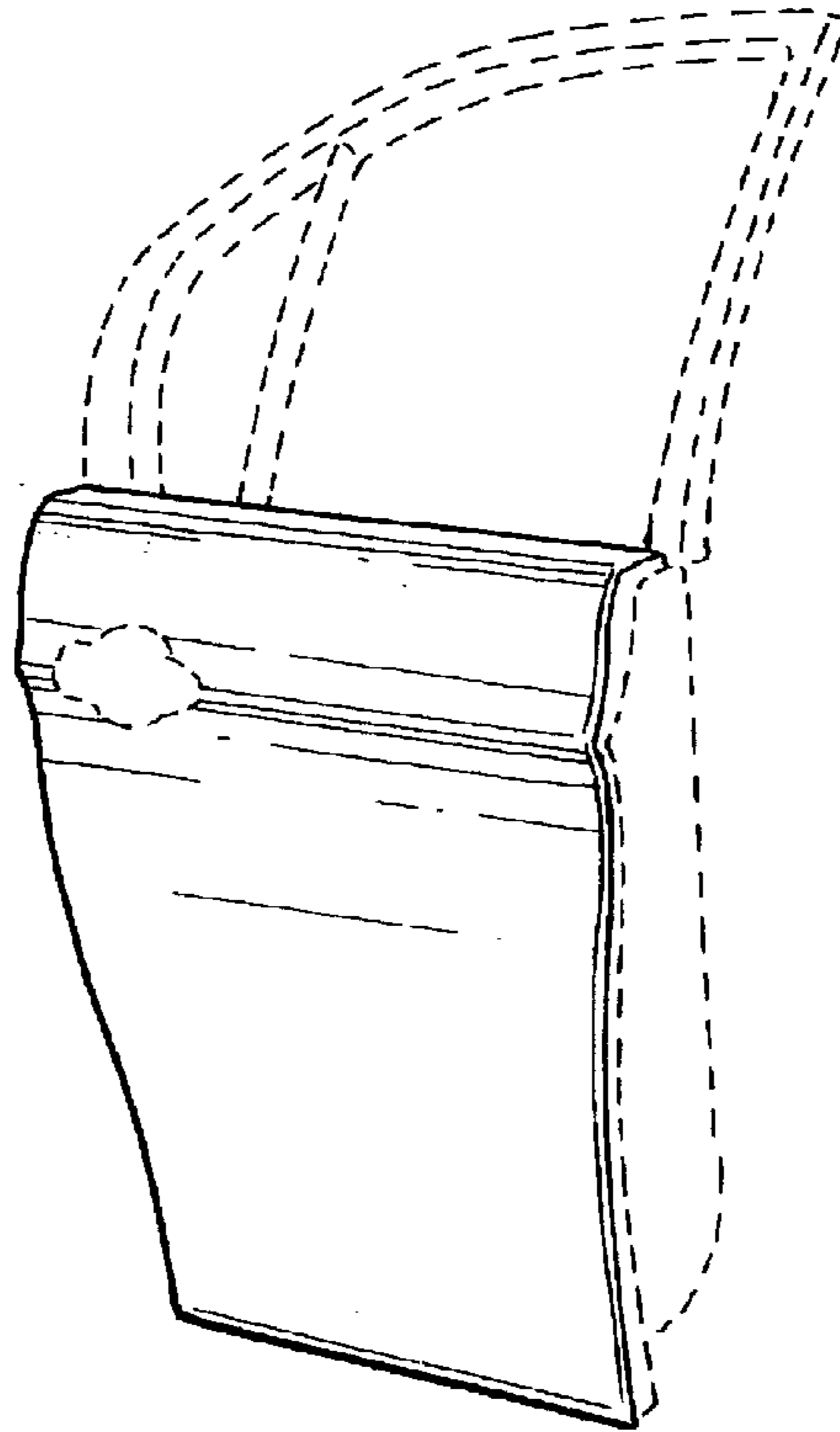

FIG. 4

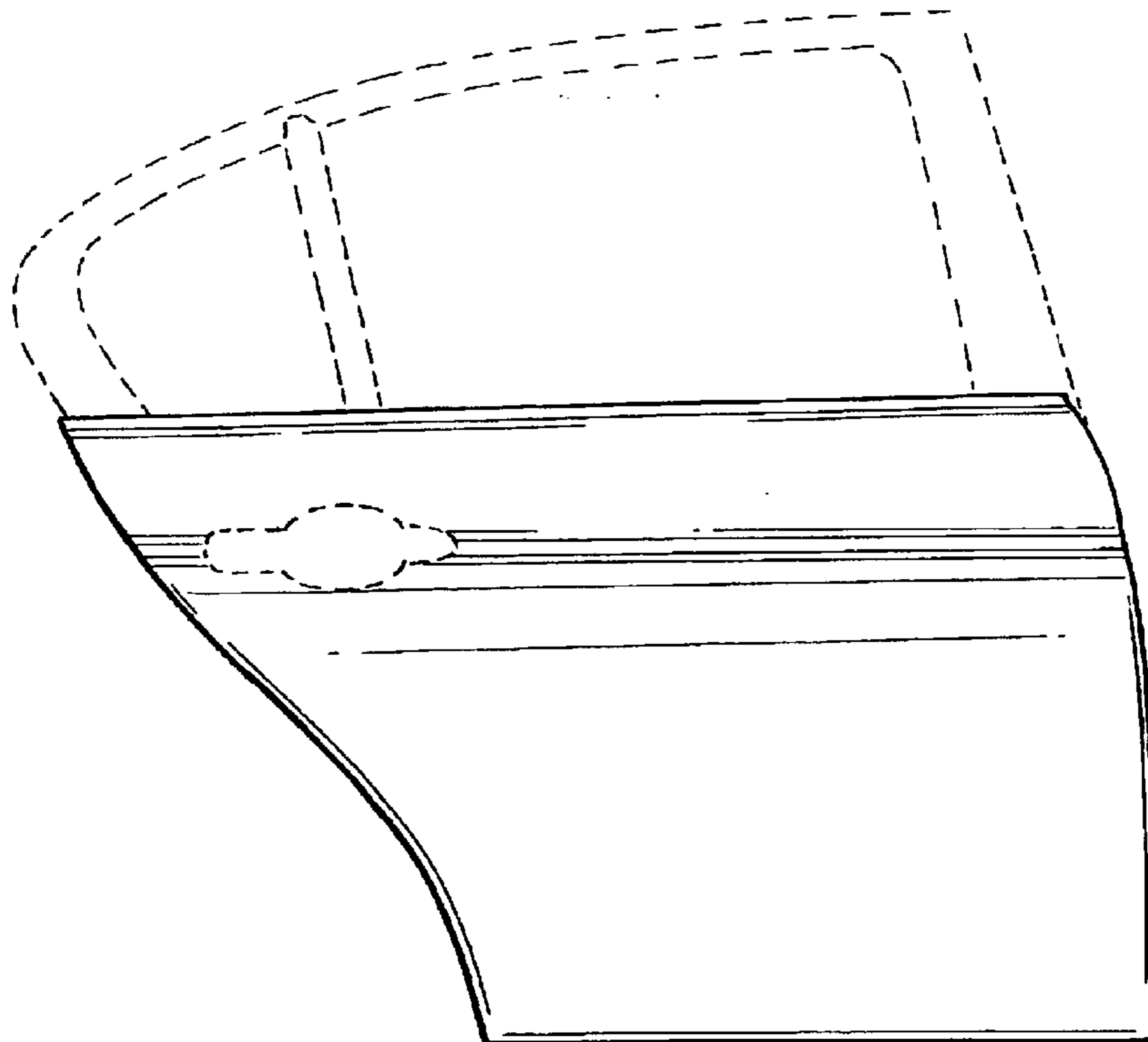

FIG. 6