



US00D511124S

(12) **United States Design Patent** (10) **Patent No.:** **US D511,124 S**  
**James** (45) **Date of Patent:** **\*\* Nov. 1, 2005**

(54) **FOOT CONTROL FOR A MOTORCYCLE FRAME**

(75) Inventor: **Jesse G. James**, Surfside, CA (US)

(73) Assignee: **West Coast Choppers, Inc.**, Long Beach, CA (US)

(\*\*) Term: **14 Years**

(21) Appl. No.: **29/194,157**

(22) Filed: **Nov. 18, 2003**

(51) **LOC (8) Cl.** ..... **12-11**

(52) **U.S. Cl.** ..... **D12/117**

(58) **Field of Search** ..... D12/110, 114,  
D12/117, 174, 179; 180/219, 311, 312;  
280/274, 281.1, 288.1-288.4, 291; 74/512,  
564; 296/75

(56) **References Cited**

**U.S. PATENT DOCUMENTS**

5,704,442 A	1/1998	Okazaki et al.
D425,453 S	5/2000	Manescalchi
D480,335 S	10/2003	James
D480,664 S	10/2003	James
D480,993 S	10/2003	James
D483,300 S	12/2003	James

**OTHER PUBLICATIONS**

U.S. Appl. No. 29/194,054, Jesse James, filed Nov. 18, 2003.\*

Custom Chrome 2001 catalog, 'Doss 230' Swingarm and Rigid model frames at top and center of p. 14.12.\*

Custom Chrome 2001 catalog, Daytec™ Wide Rigid Frame at bottom of p. 14.19.\*

\* cited by examiner

*Primary Examiner*—Alan P. Douglas  
*Assistant Examiner*—Linda Brooks

(57) **CLAIM**

The ornamental design for a foot control for a motorcycle frame, substantially as shown and described.

**DESCRIPTION**

FIG. 1 is a front elevational view of the foot control for a motorcycle frame showing my new design;  
FIG. 2 is an enlarged front elevational view;  
FIG. 3 is an enlarged rear elevational view of the foot control of FIG. 2;

FIG. 4 is an enlarged top plan view of the foot control of FIG. 2;

FIG. 5 is an enlarged bottom plan view of the foot control of FIG. 2;

FIG. 6 is an enlarged right side elevational view of the foot control of FIG. 2;

FIG. 7 is an enlarged left side elevational view of the foot control of FIG. 2;

FIG. 8 is an enlarged front elevational view of a second embodiment of the foot control for a motorcycle frame showing my new design;

FIG. 9 is an enlarged rear elevational view of the foot control of FIG. 8;

FIG. 10 is an enlarged top plan view of the foot control of FIG. 8;

FIG. 11 is an enlarged bottom plan view of the foot control of FIG. 8;

FIG. 12 is an enlarged right side elevational view of the foot control of FIG. 8; and,

FIG. 13 is an enlarged left side elevational view of the foot control of FIG. 8.

The dotted lines showing a motorcycle in FIG. 1 are environmental only and form no part of the claimed design.

**1 Claim, 4 Drawing Sheets**

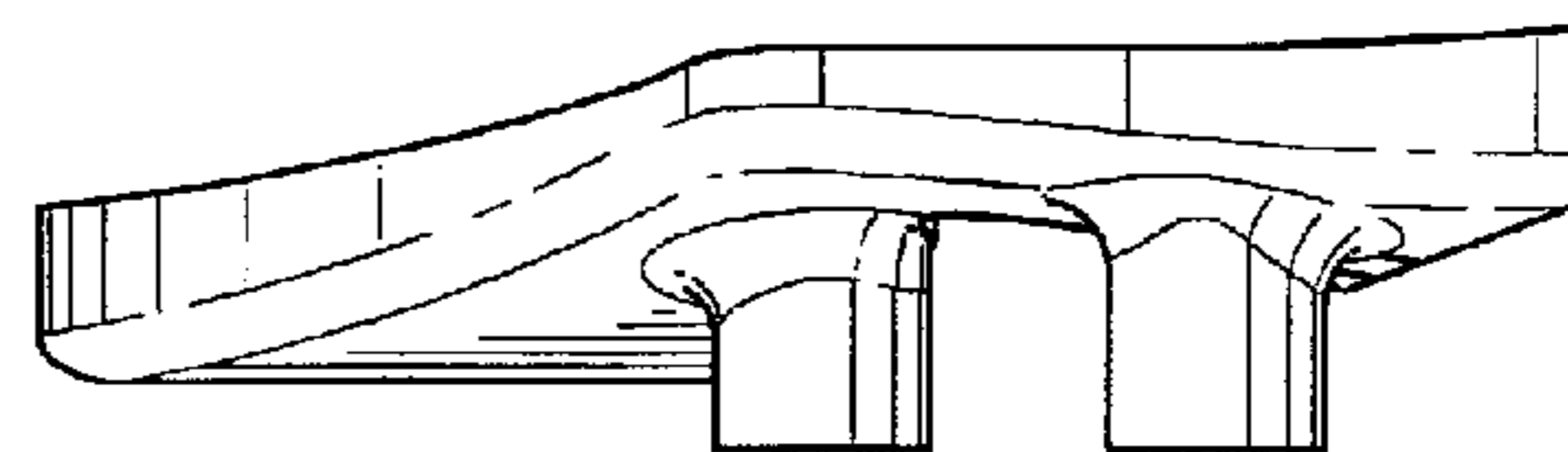
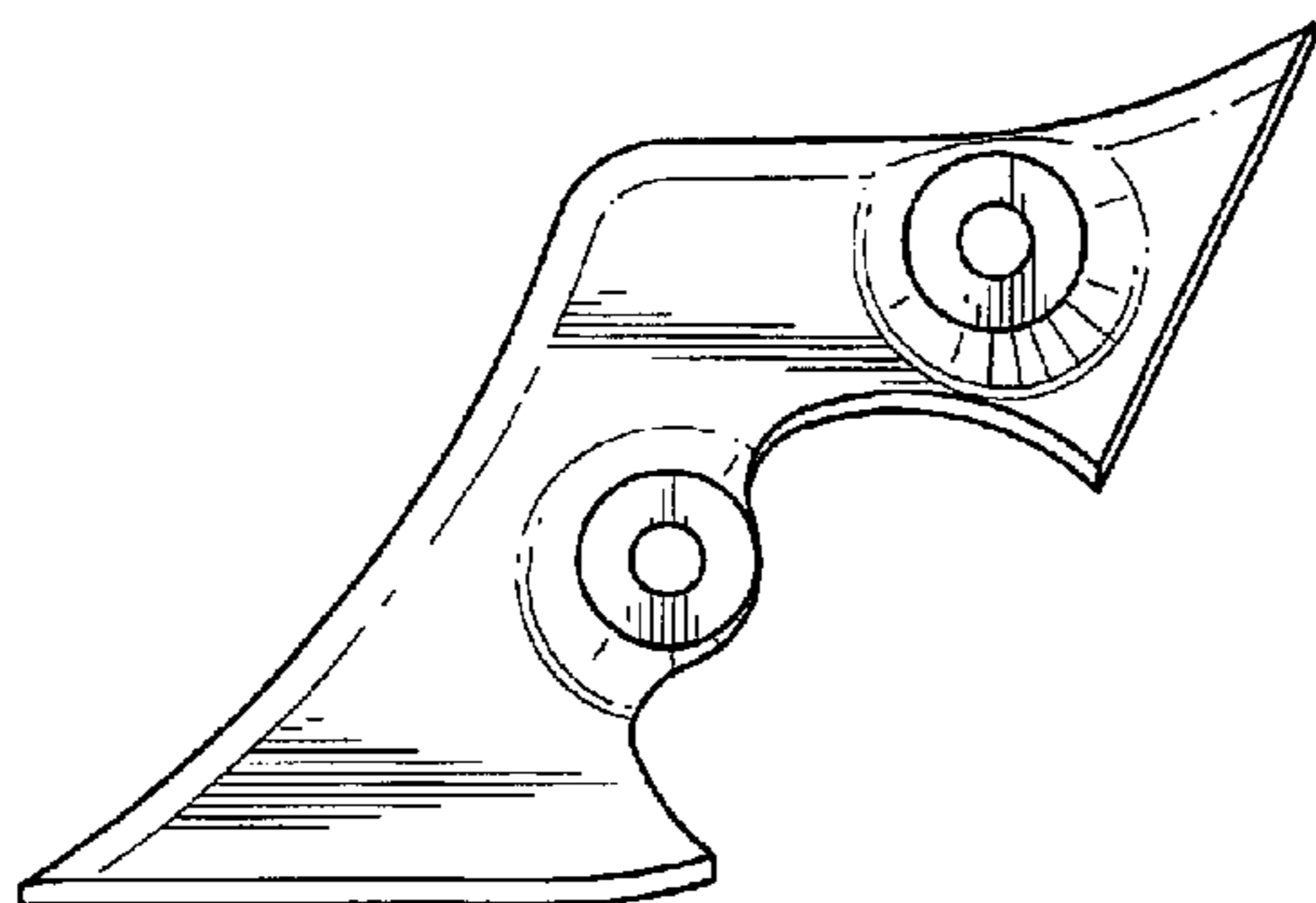

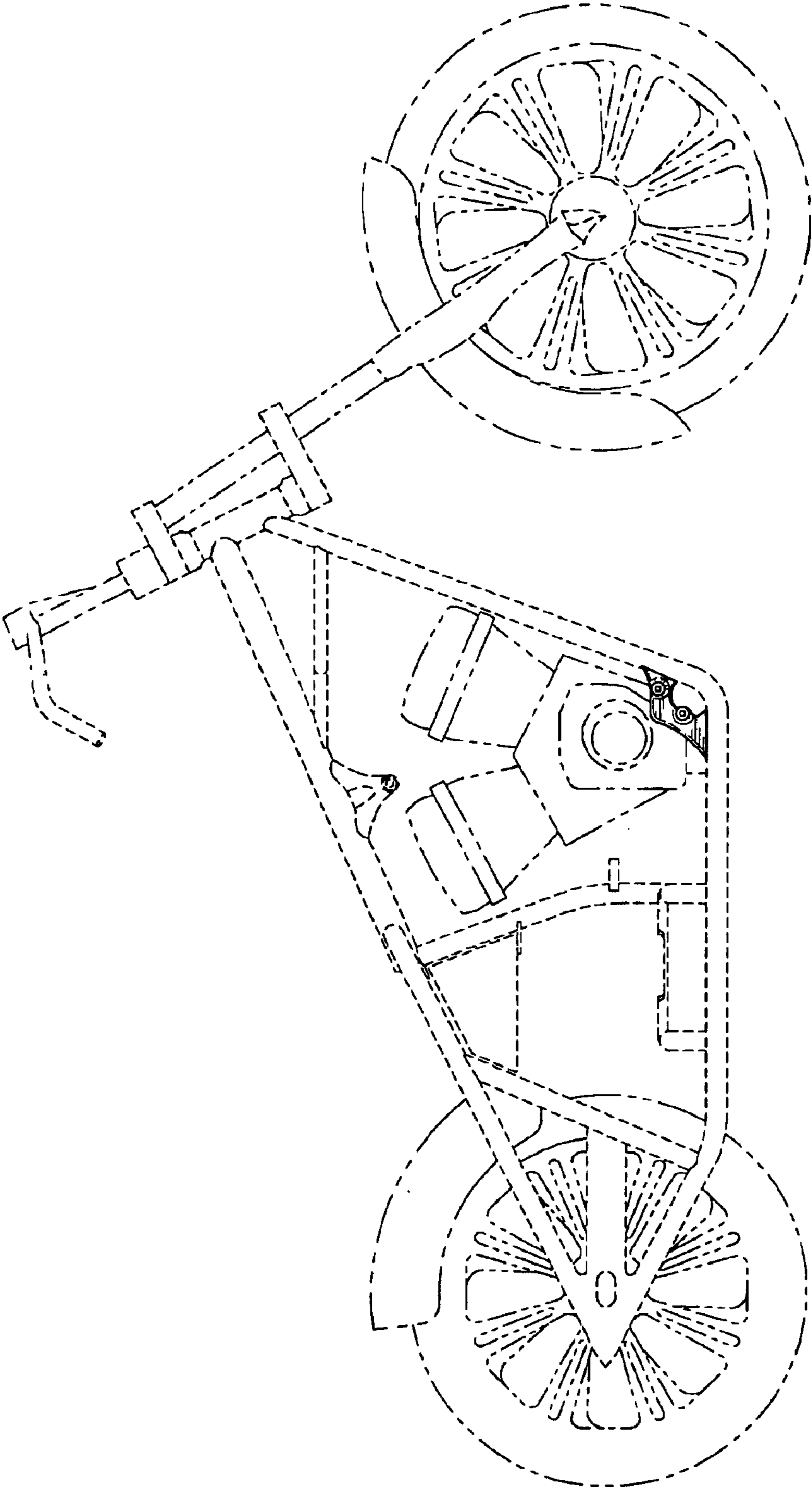

FIG. 1

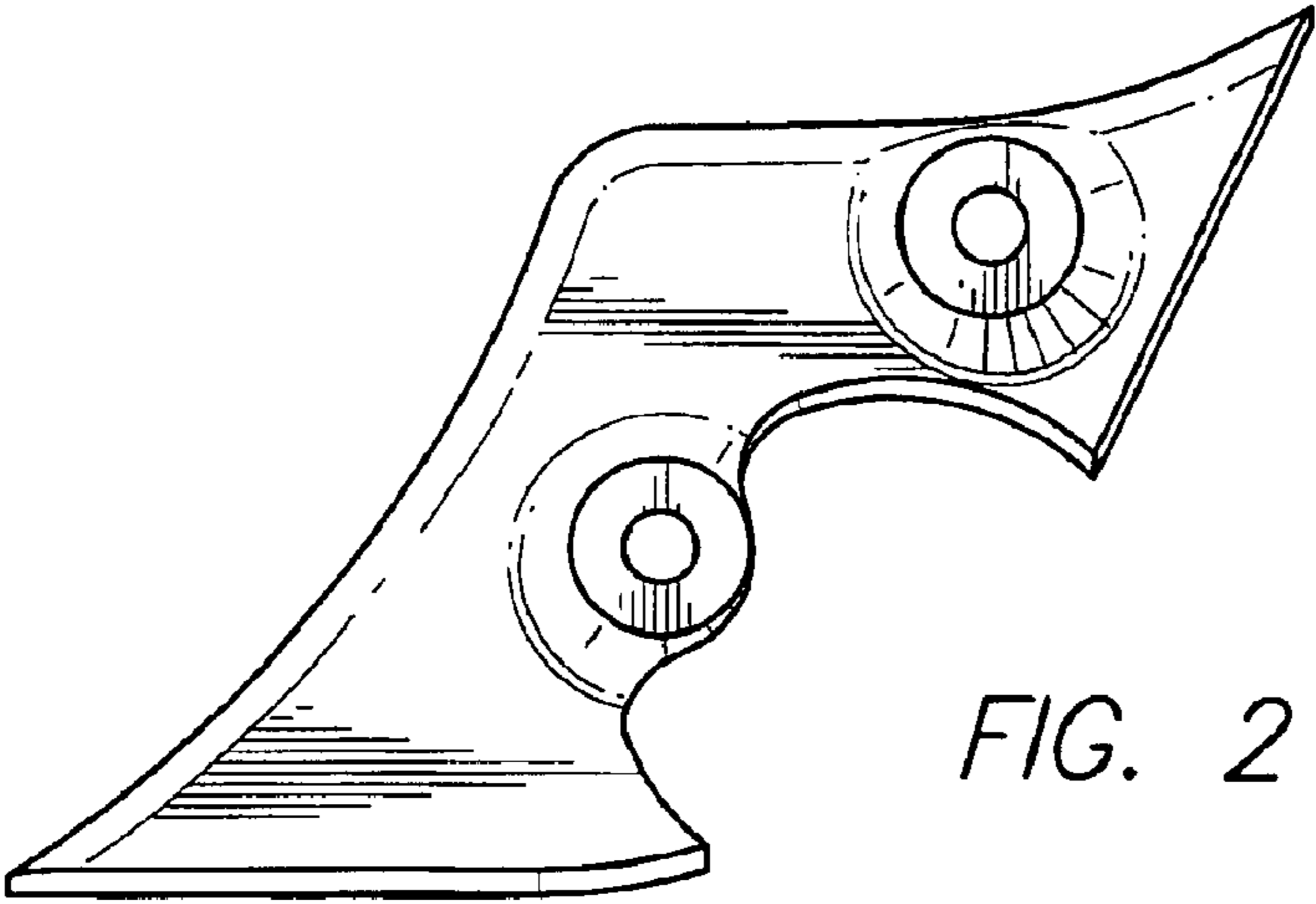

FIG. 2

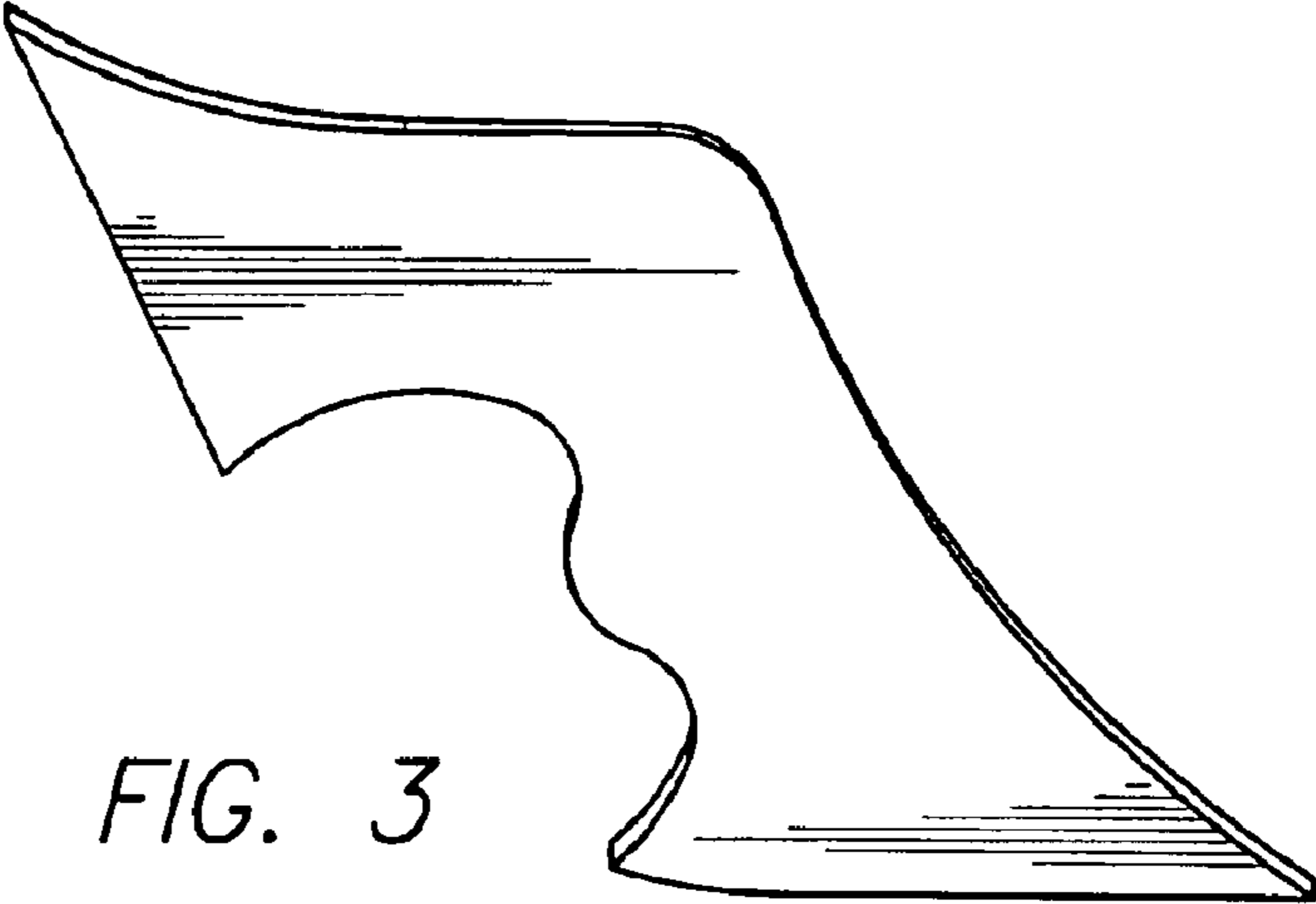

FIG. 3

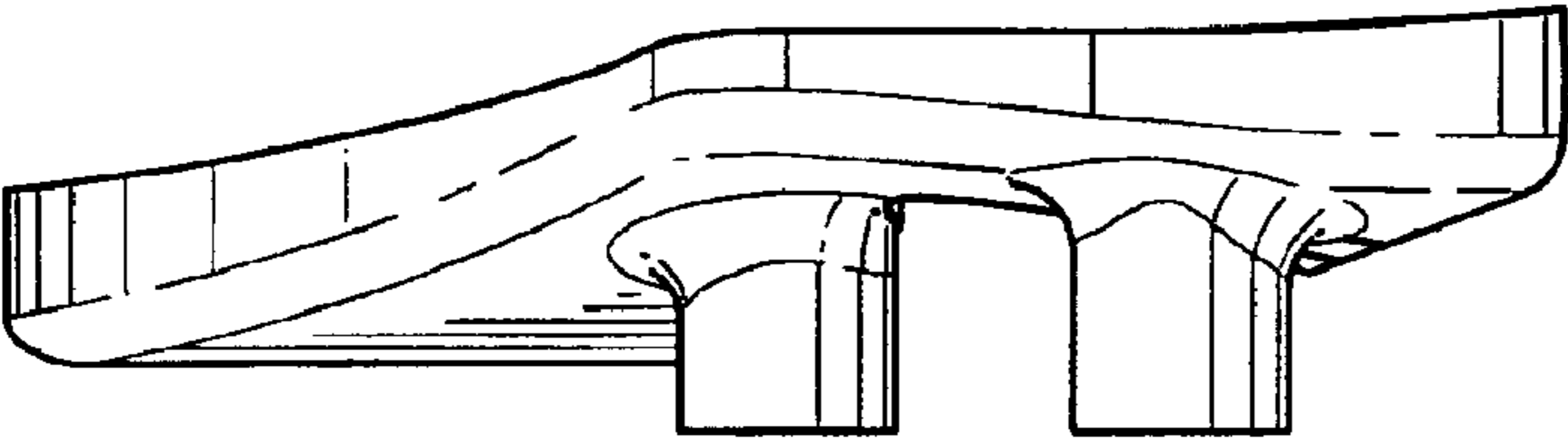

FIG. 4

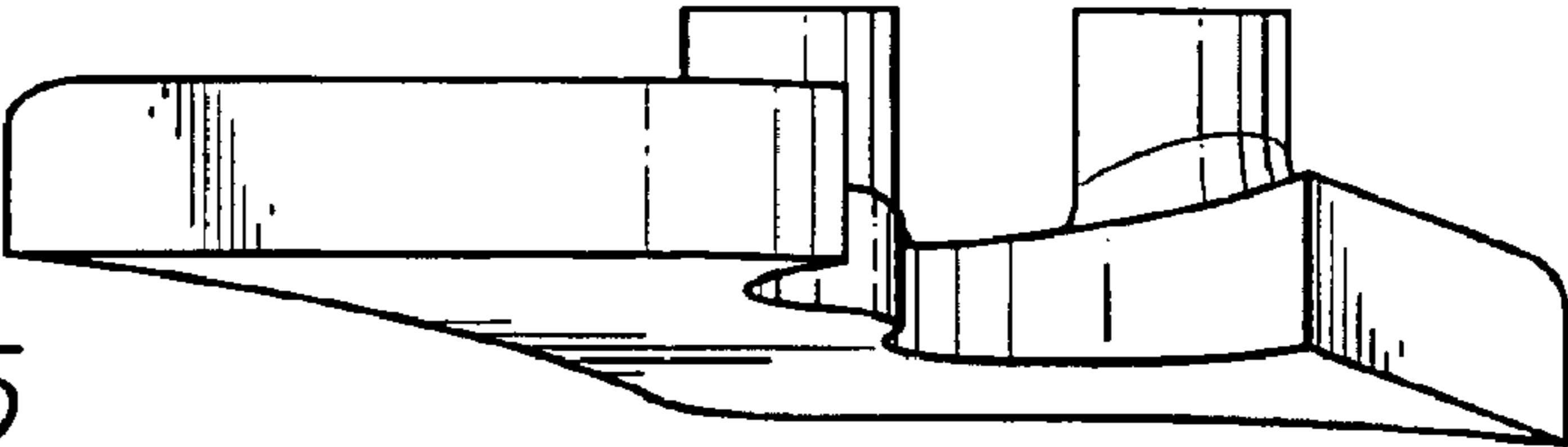

FIG. 5

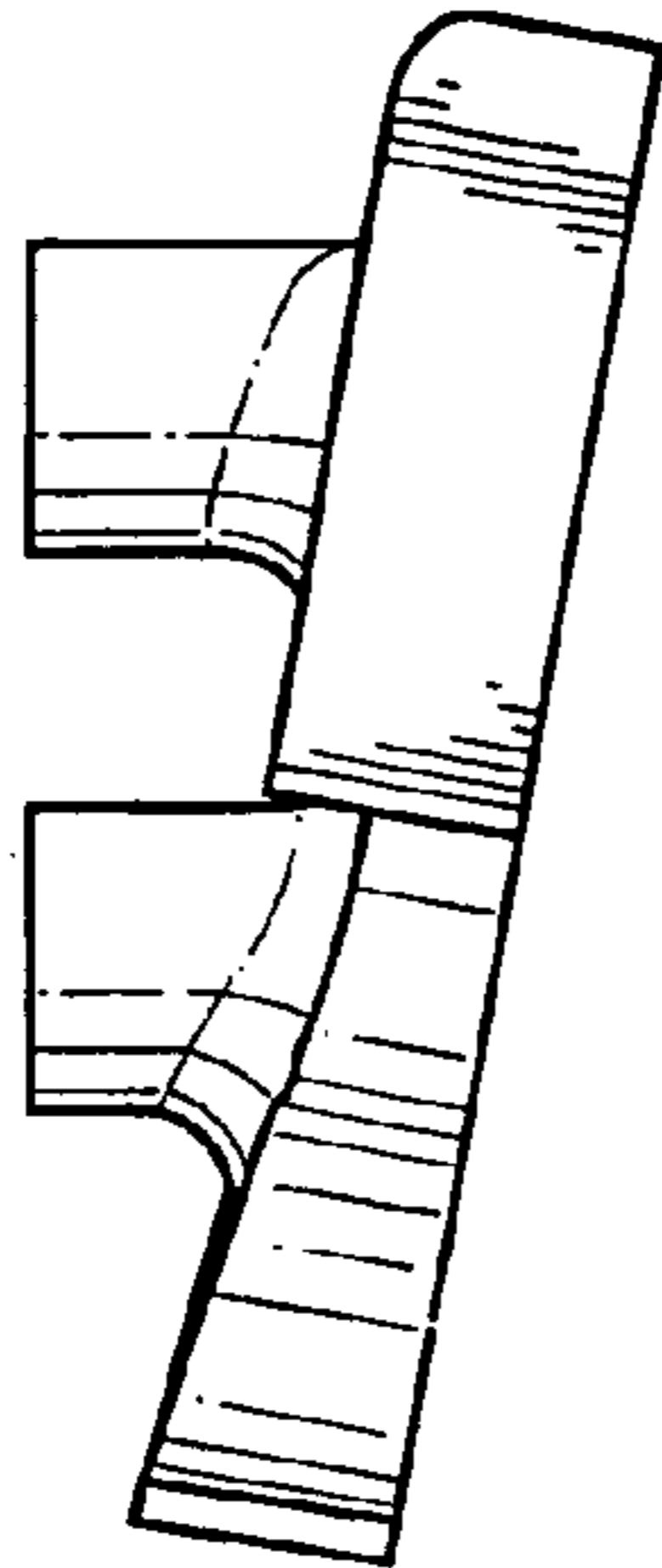

FIG. 6

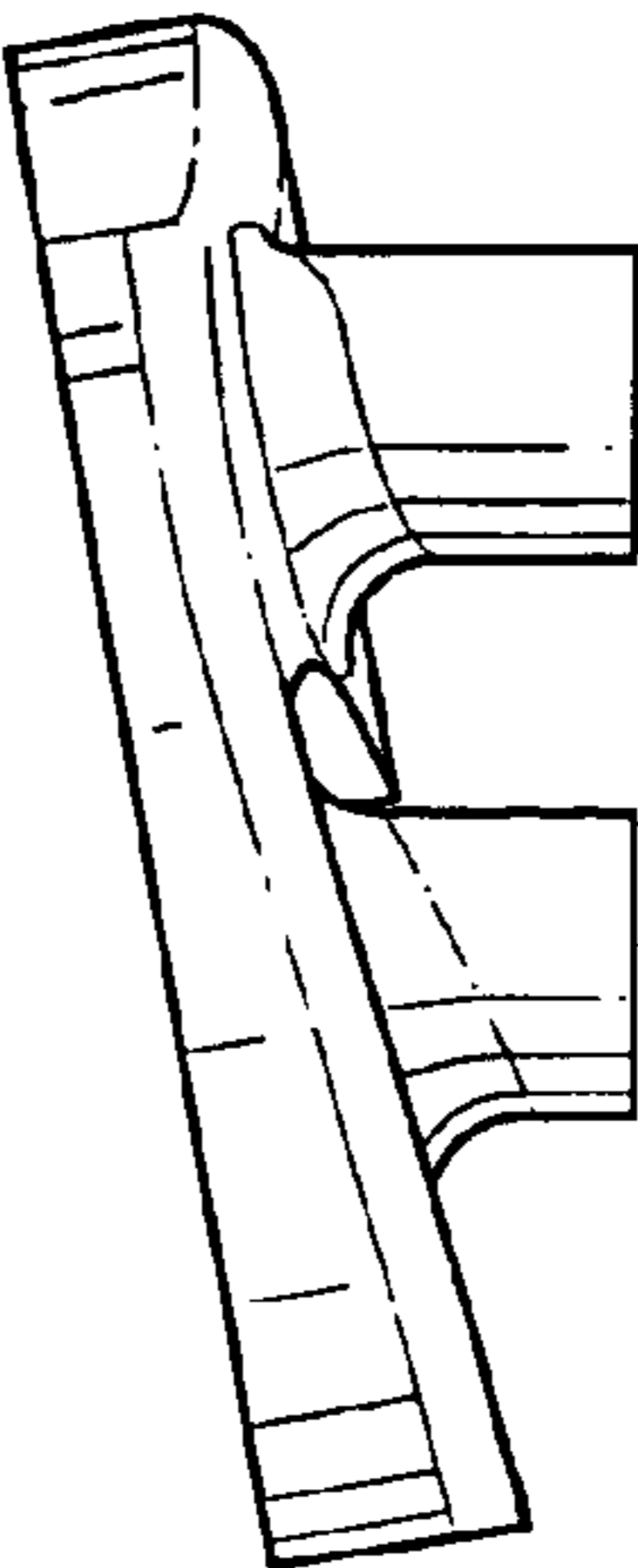

FIG. 7

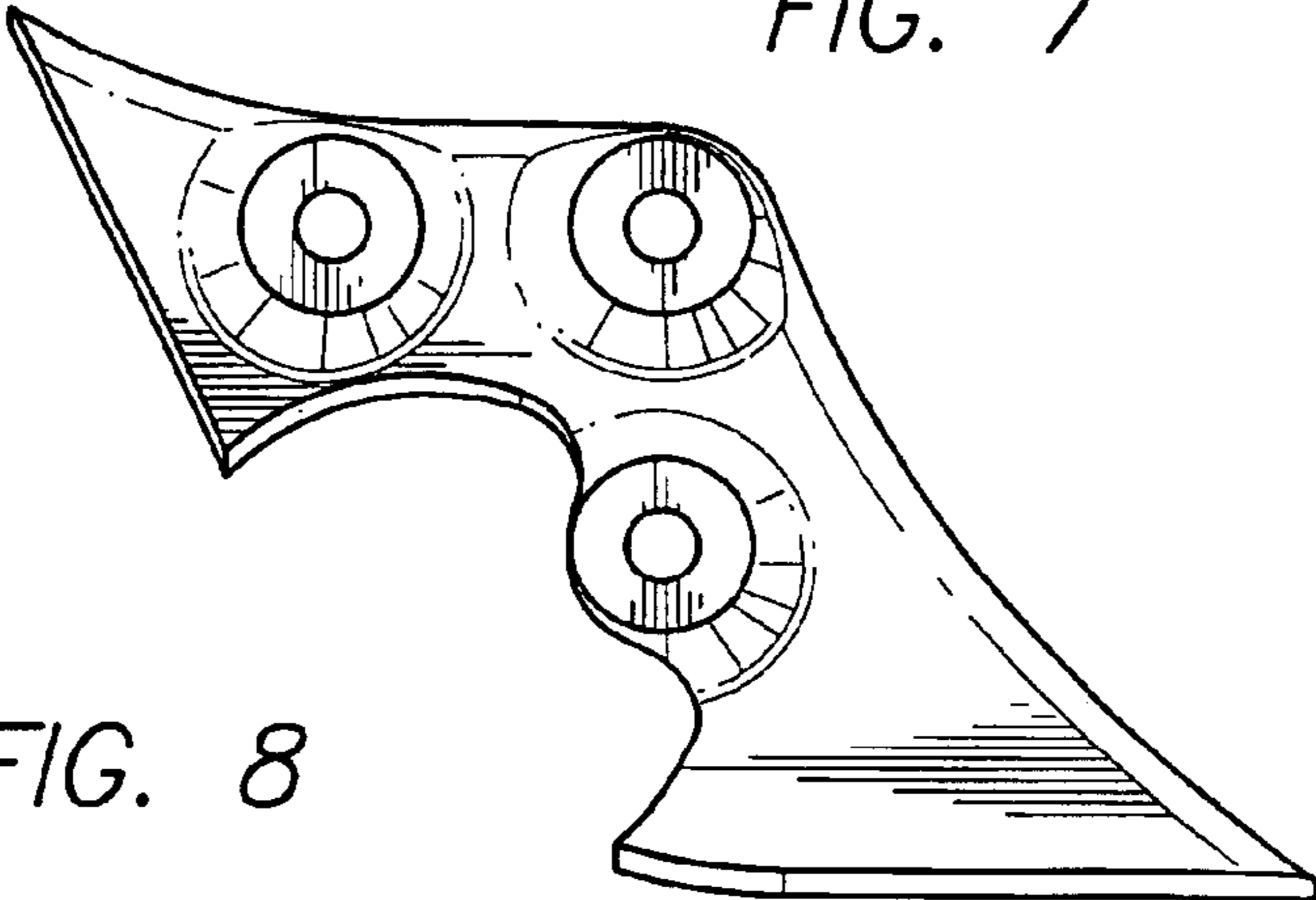

FIG. 8

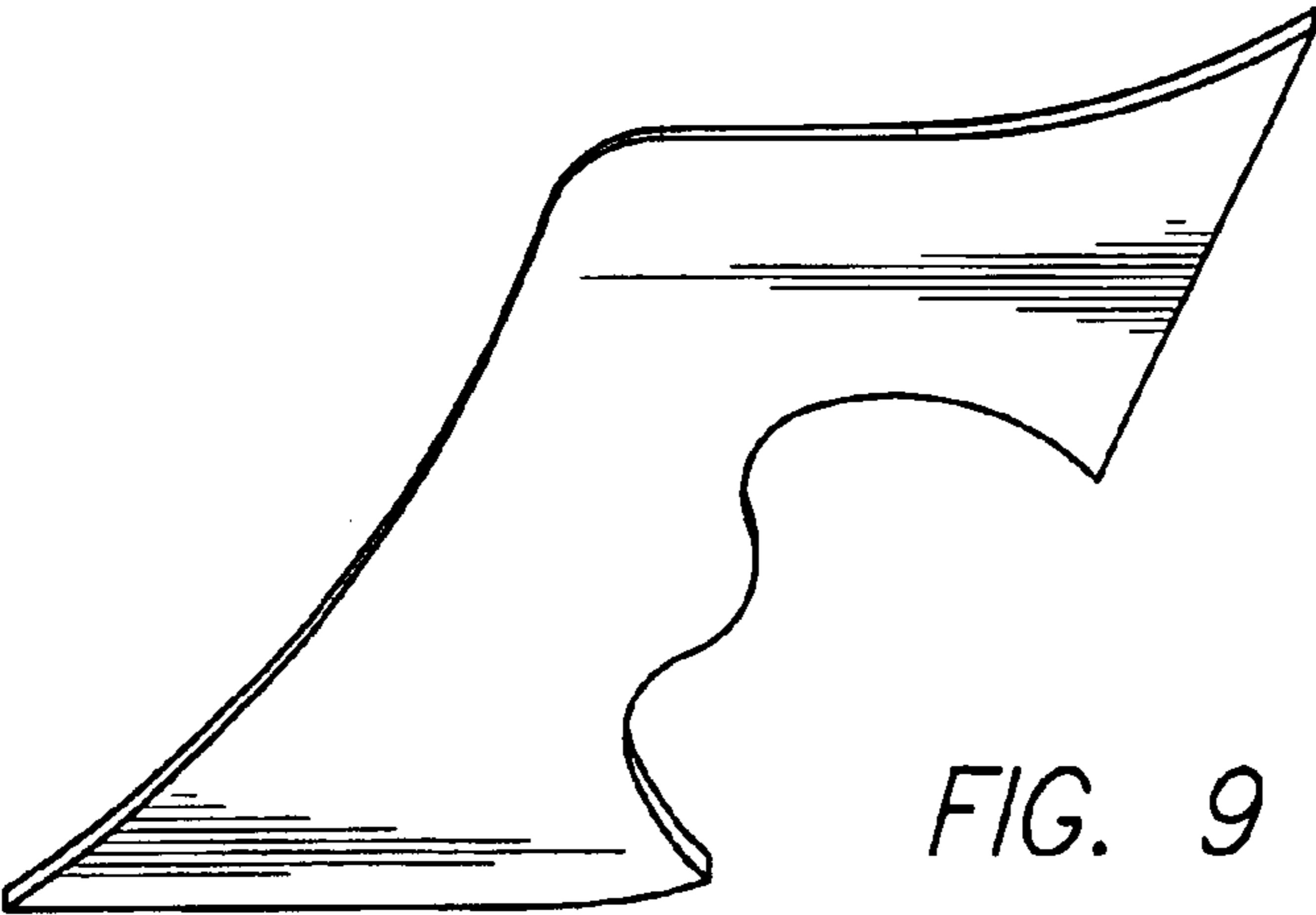

FIG. 9

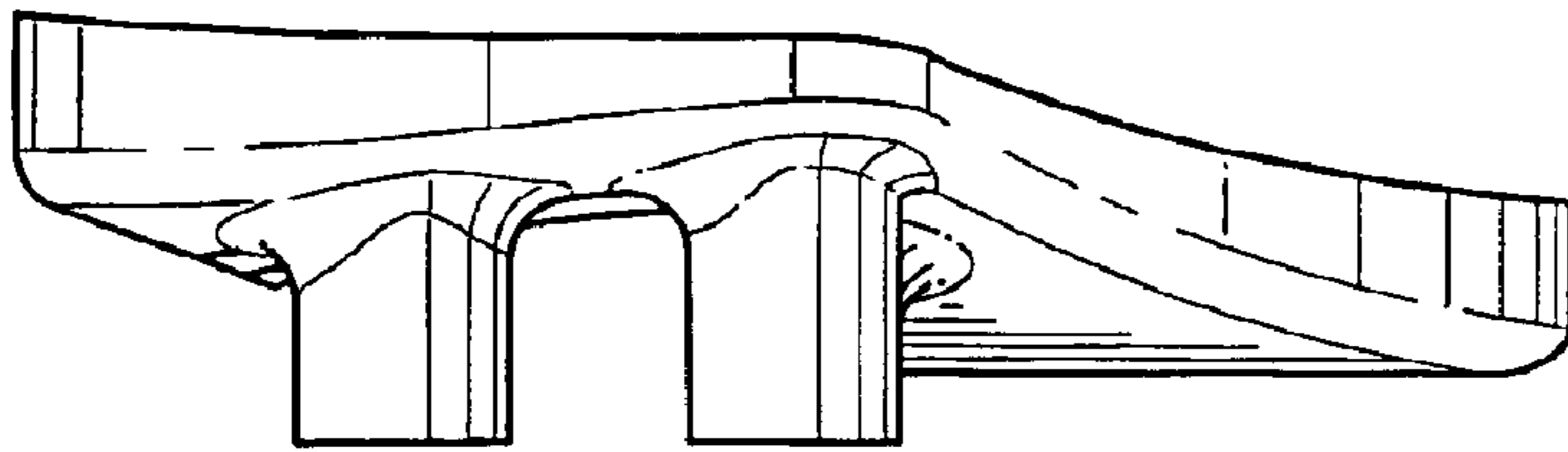

FIG. 10

FIG. 11

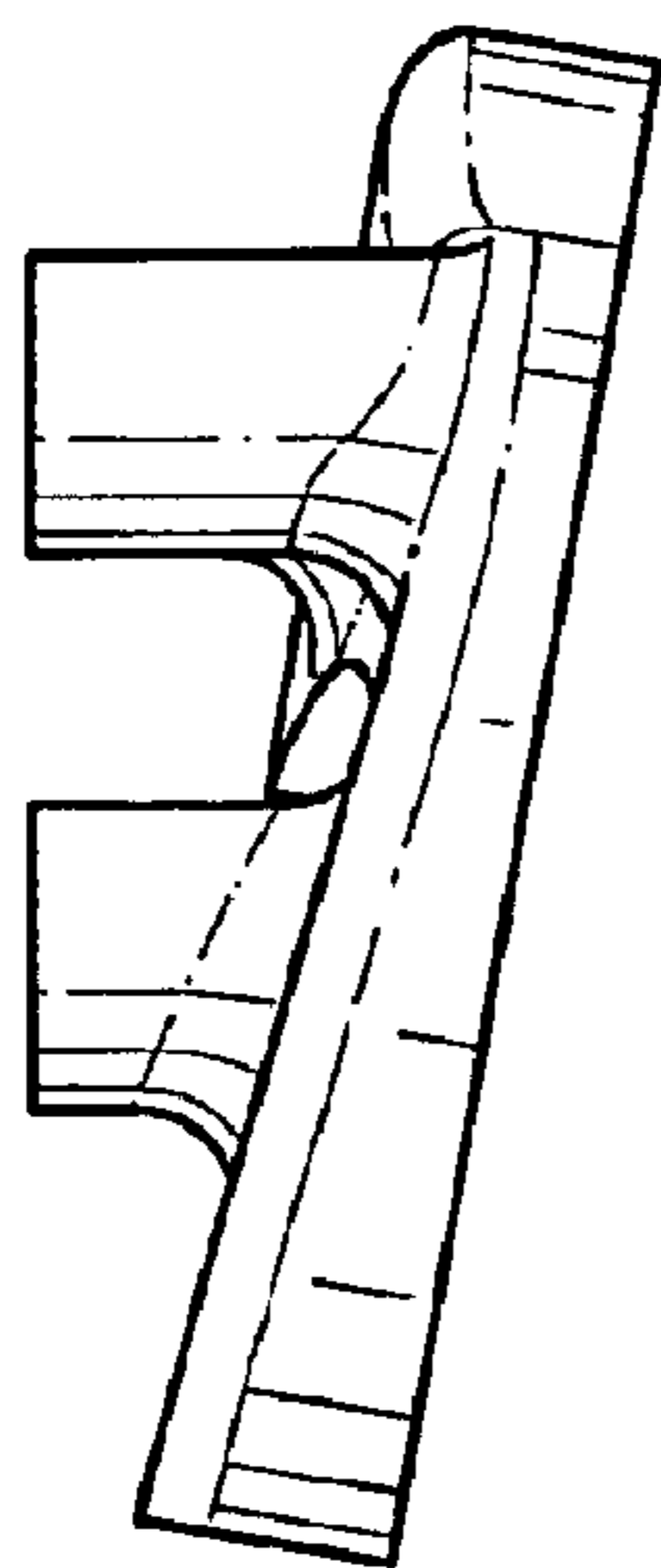
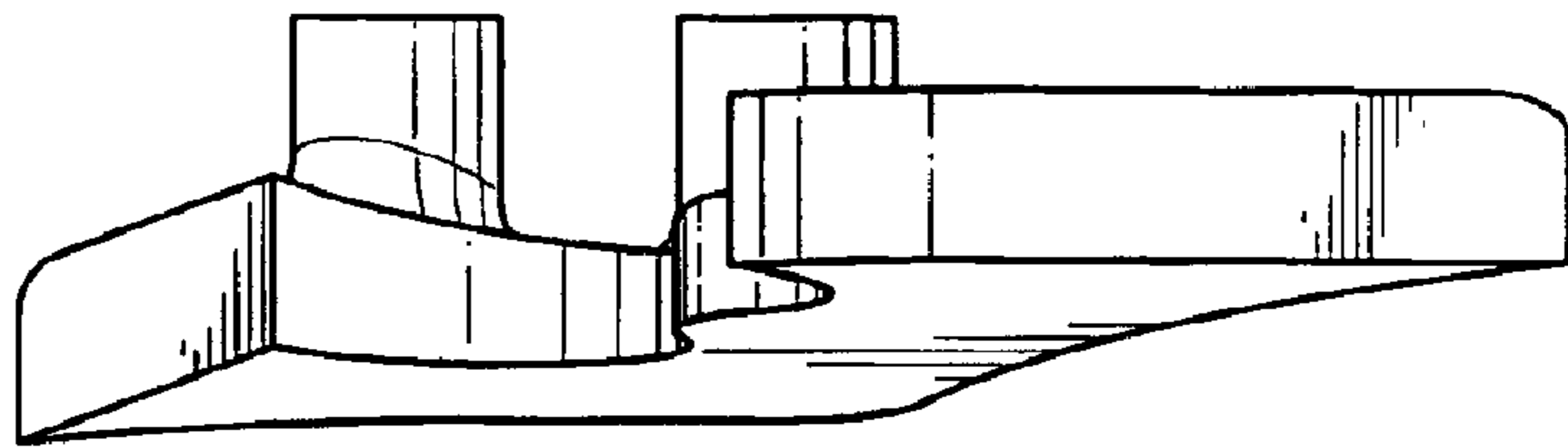

FIG. 12

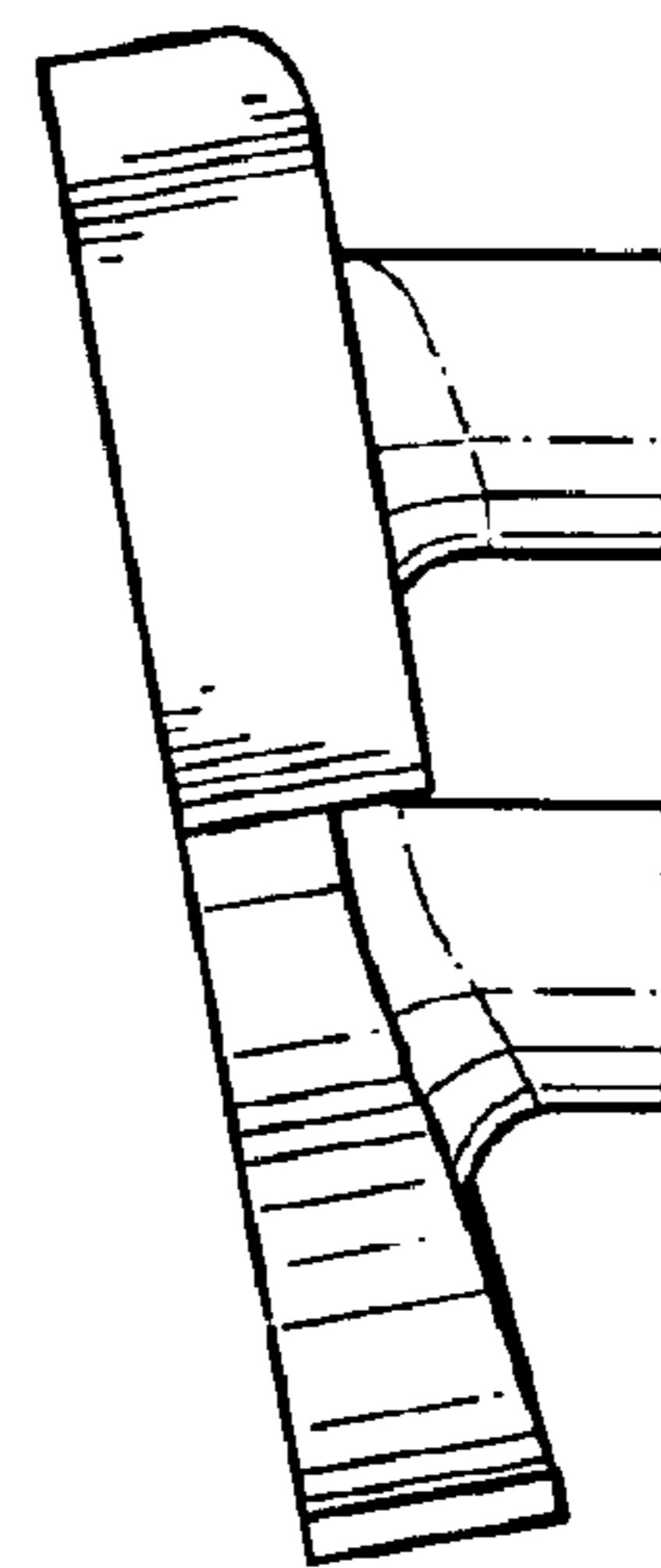

FIG. 13