



US00D511123S

(12) **United States Design Patent**  
**Lin**

(10) **Patent No.:** **US D511,123 S**

(45) **Date of Patent:** **\*\* Nov. 1, 2005**

(54) **ALL-TERRAIN VEHICLE**

D452,835 S \* 1/2002 Aoki et al. .... D12/107

(75) **Inventor:** **Ching-Hua Lin, Ta-Li (TW)**

\* cited by examiner

(73) **Assignee:** **CPI Motor Co., Ta-Li (TW)**

*Primary Examiner*—Alan P. Douglas

*Assistant Examiner*—Linda Brooks

(\*\*) **Term:** **14 Years**

(74) *Attorney, Agent, or Firm*—Alan D. Kamrath; Nikolai & Mersereau, P.A.

(21) **Appl. No.:** **29/210,079**

(57) **CLAIM**

(22) **Filed:** **Jul. 26, 2004**

The ornamental design for an all-terrain vehicle, as shown.

(51) **LOC (8) Cl.** ..... **12-11**

**DESCRIPTION**

(52) **U.S. Cl.** ..... **D12/107**

(58) **Field of Search** ..... D12/107, 87, 104;  
1080/229, 233, 311, 312, 225, 315

FIG. 1 is a perspective view of an all-terrain vehicle, showing my new design;

FIG. 2 is a front view thereof;

FIG. 3 is a rear view thereof;

FIG. 4 is a left view thereof;

FIG. 5 is a right view thereof;

FIG. 6 is top view thereof; and,

FIG. 7 is a bottom view thereof.

(56) **References Cited**

**U.S. PATENT DOCUMENTS**

D297,132 S \* 8/1988 Ryuzoji et al. .... D12/107

D327,457 S \* 6/1992 Saito ..... D12/107

D412,464 S \* 8/1999 Ichihara et al. .... D12/107

D446,475 S \* 8/2001 Luh ..... D12/107

**1 Claim, 4 Drawing Sheets**

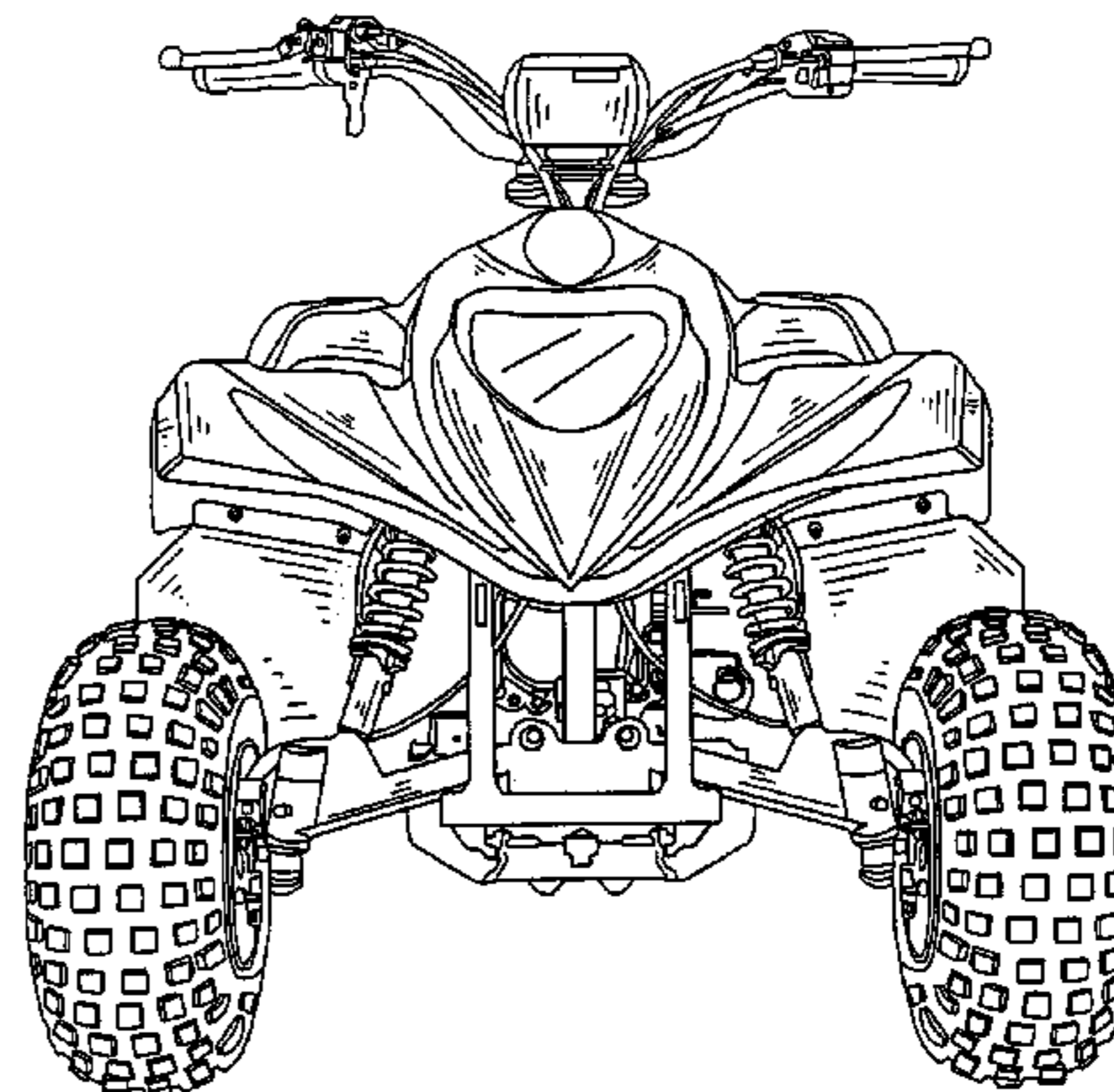
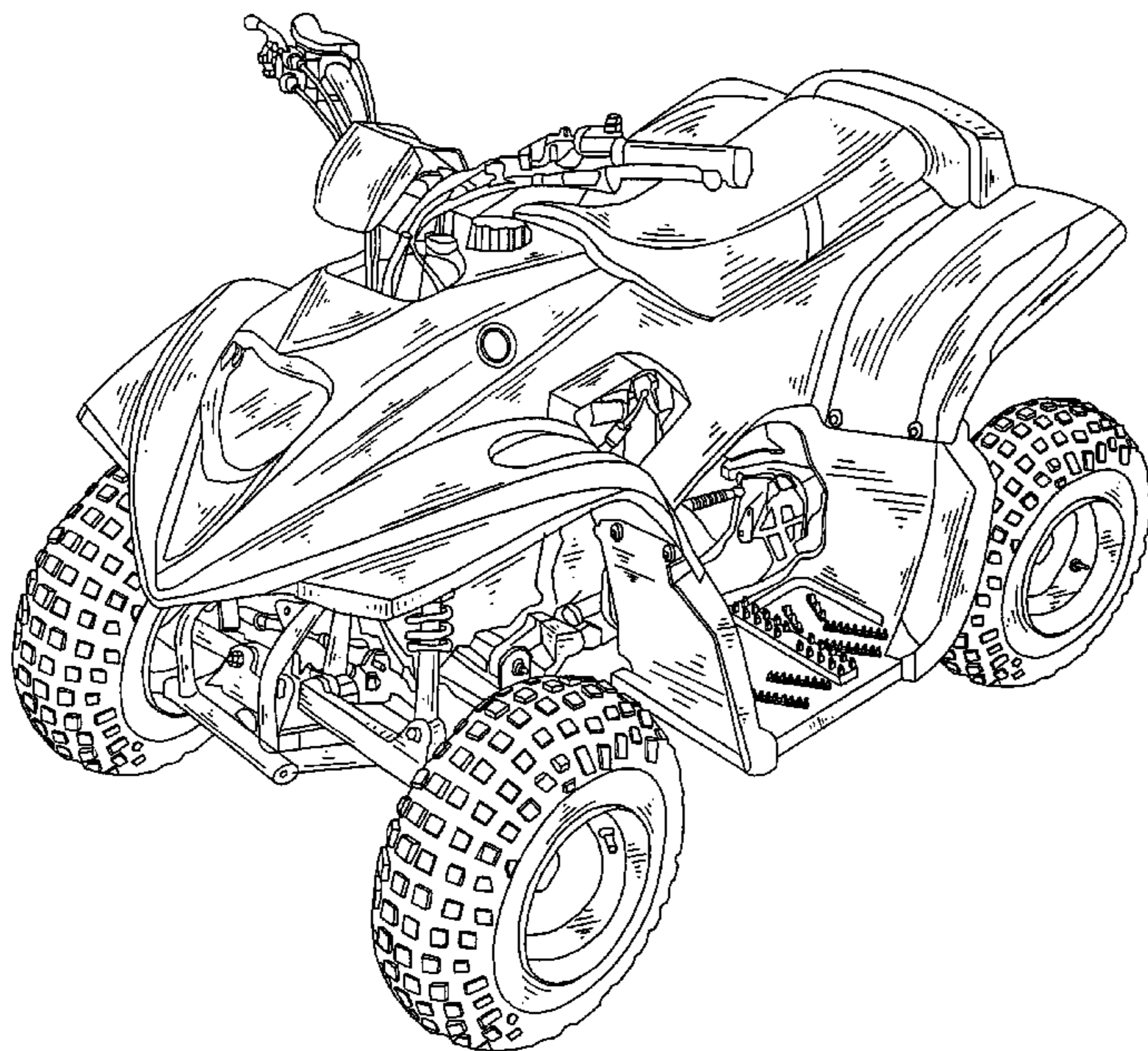



FIG. 1

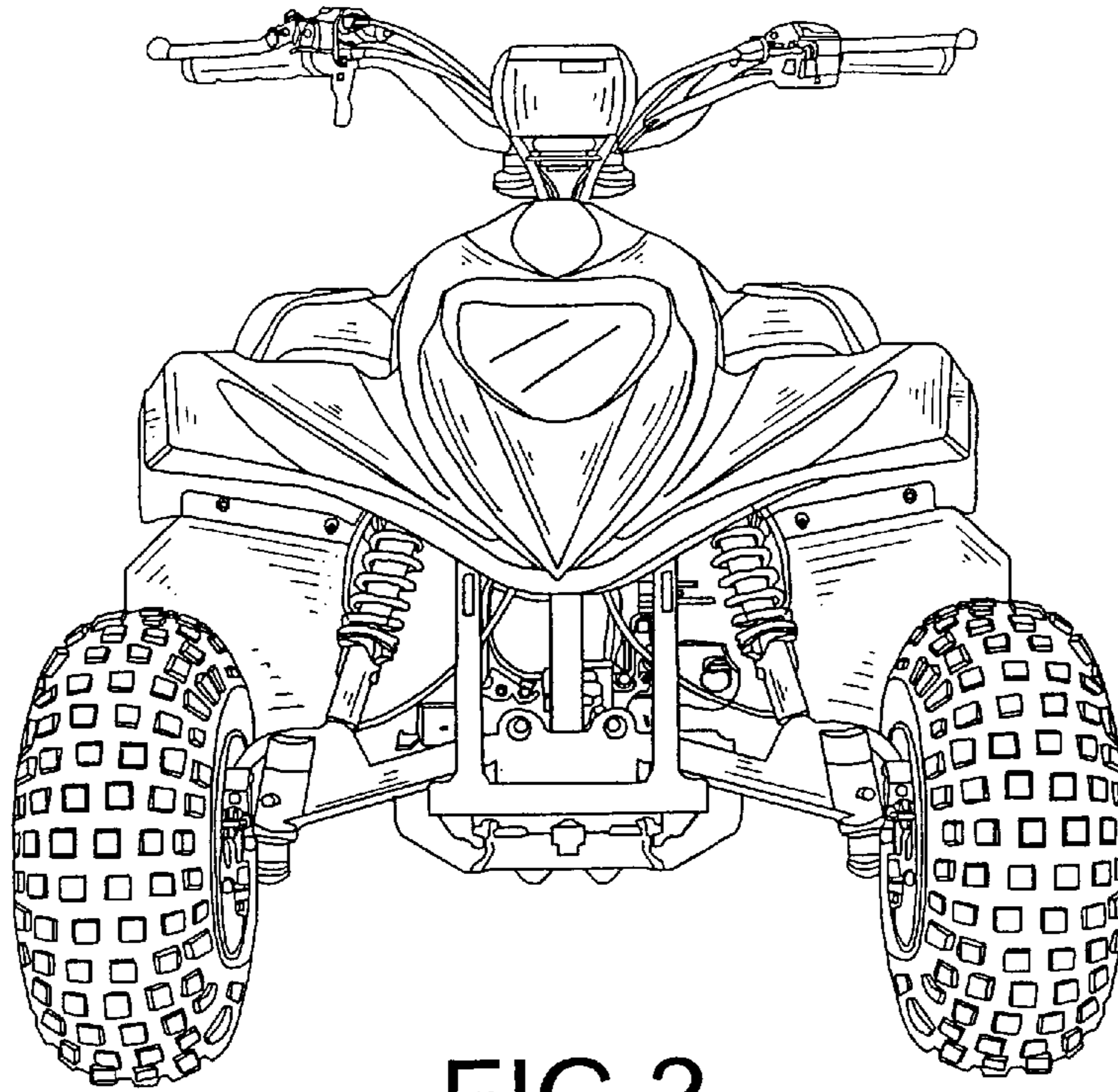

FIG.2

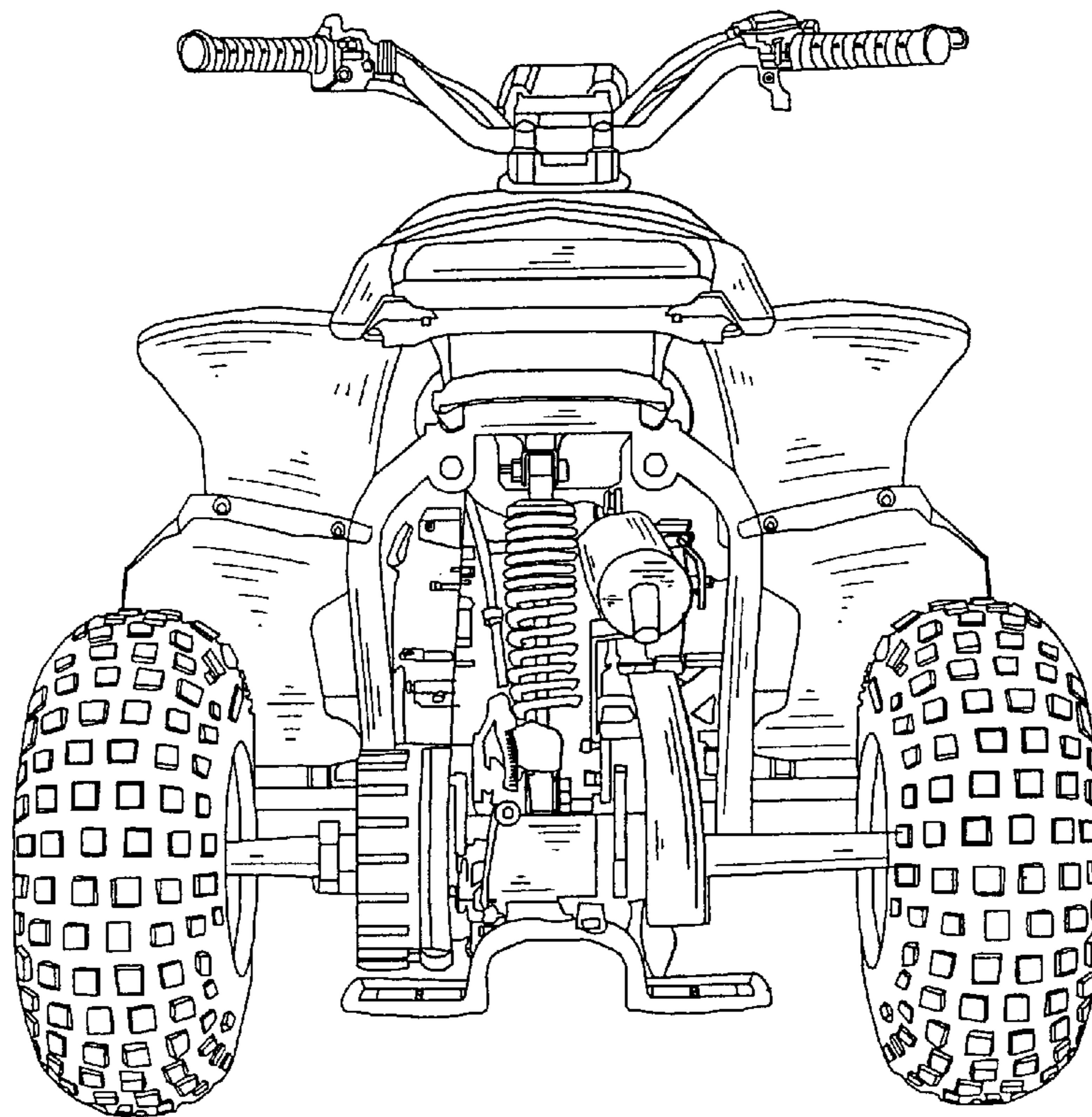

FIG.3

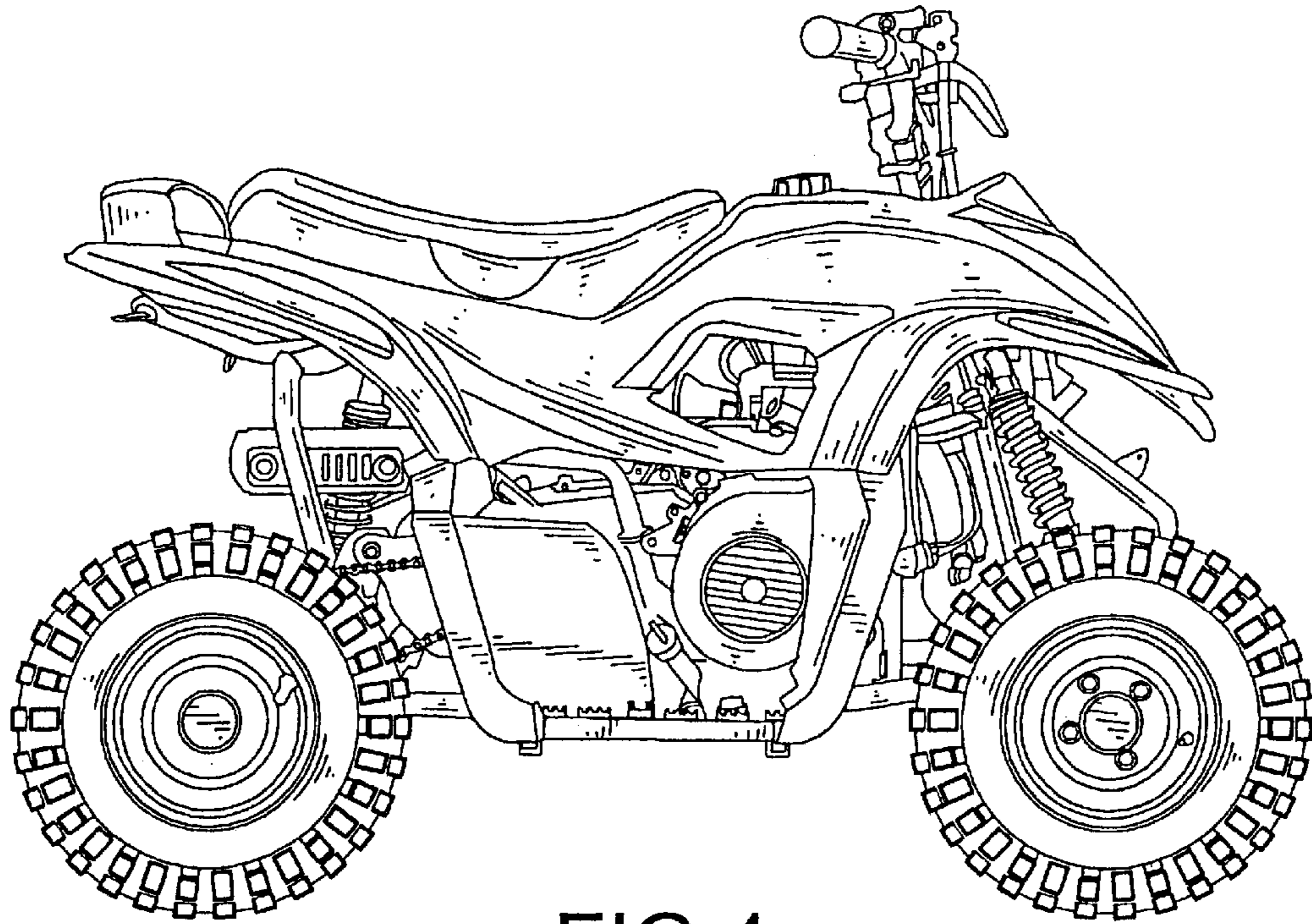

FIG.4

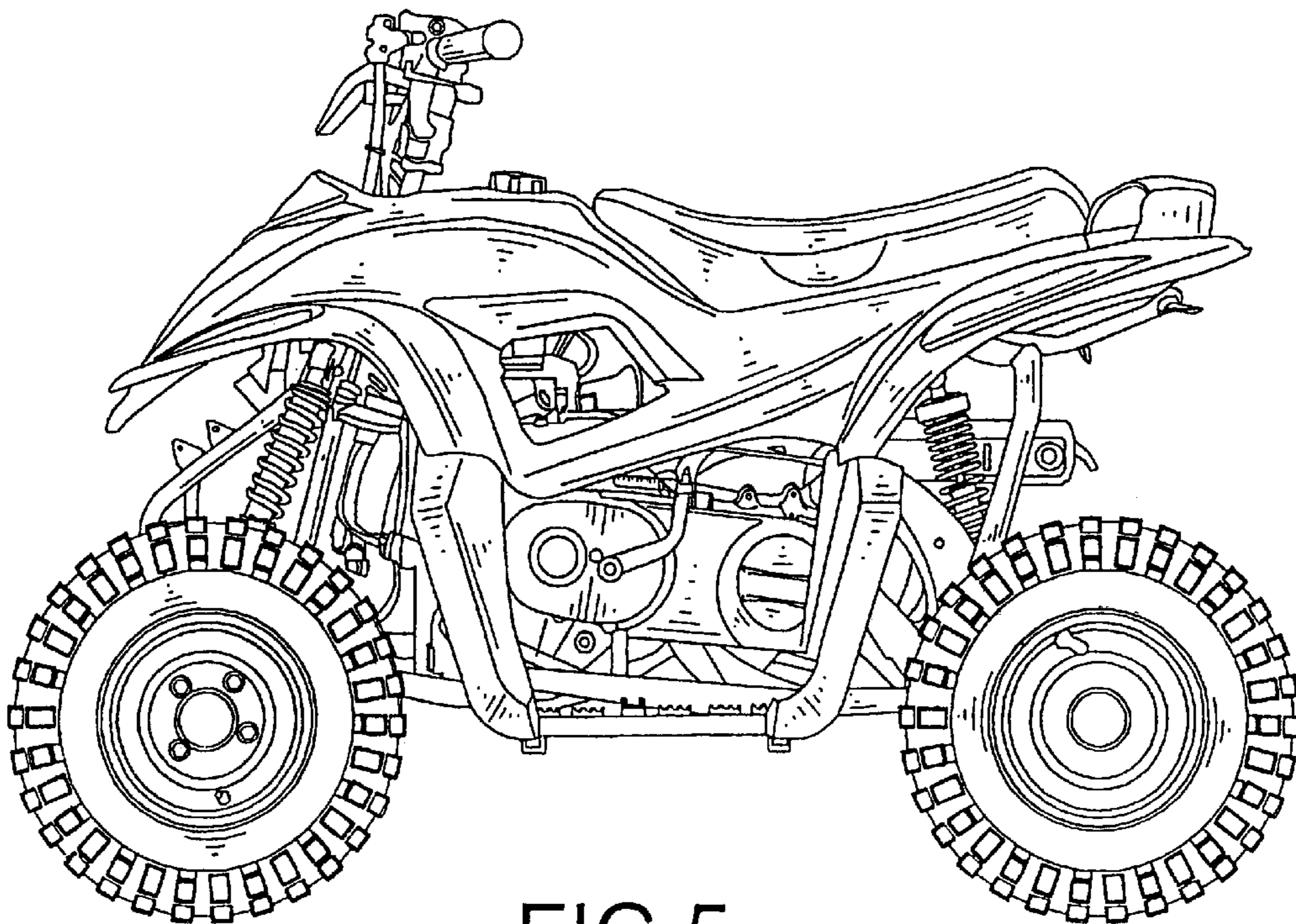

FIG.5

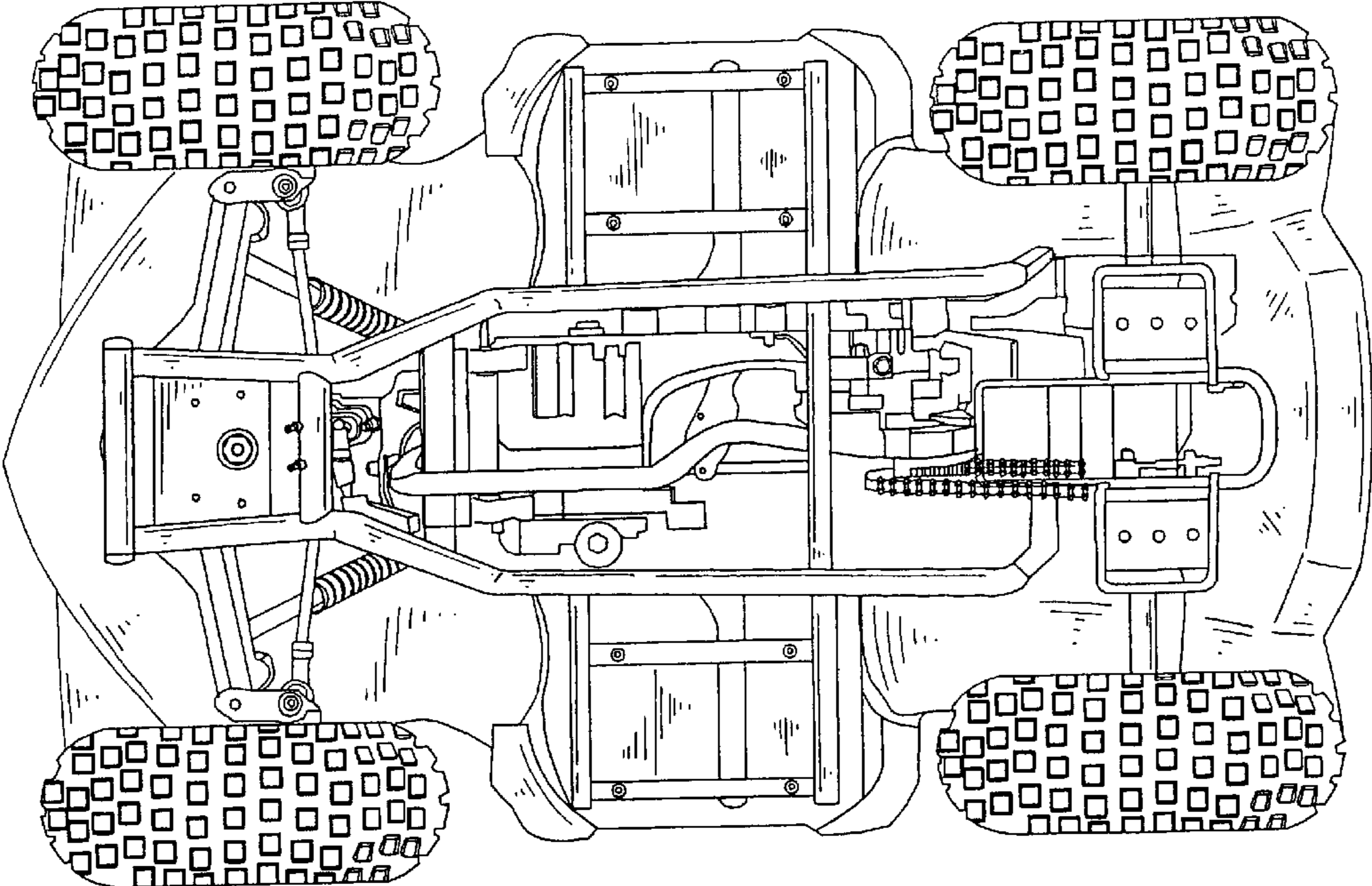

FIG. 7

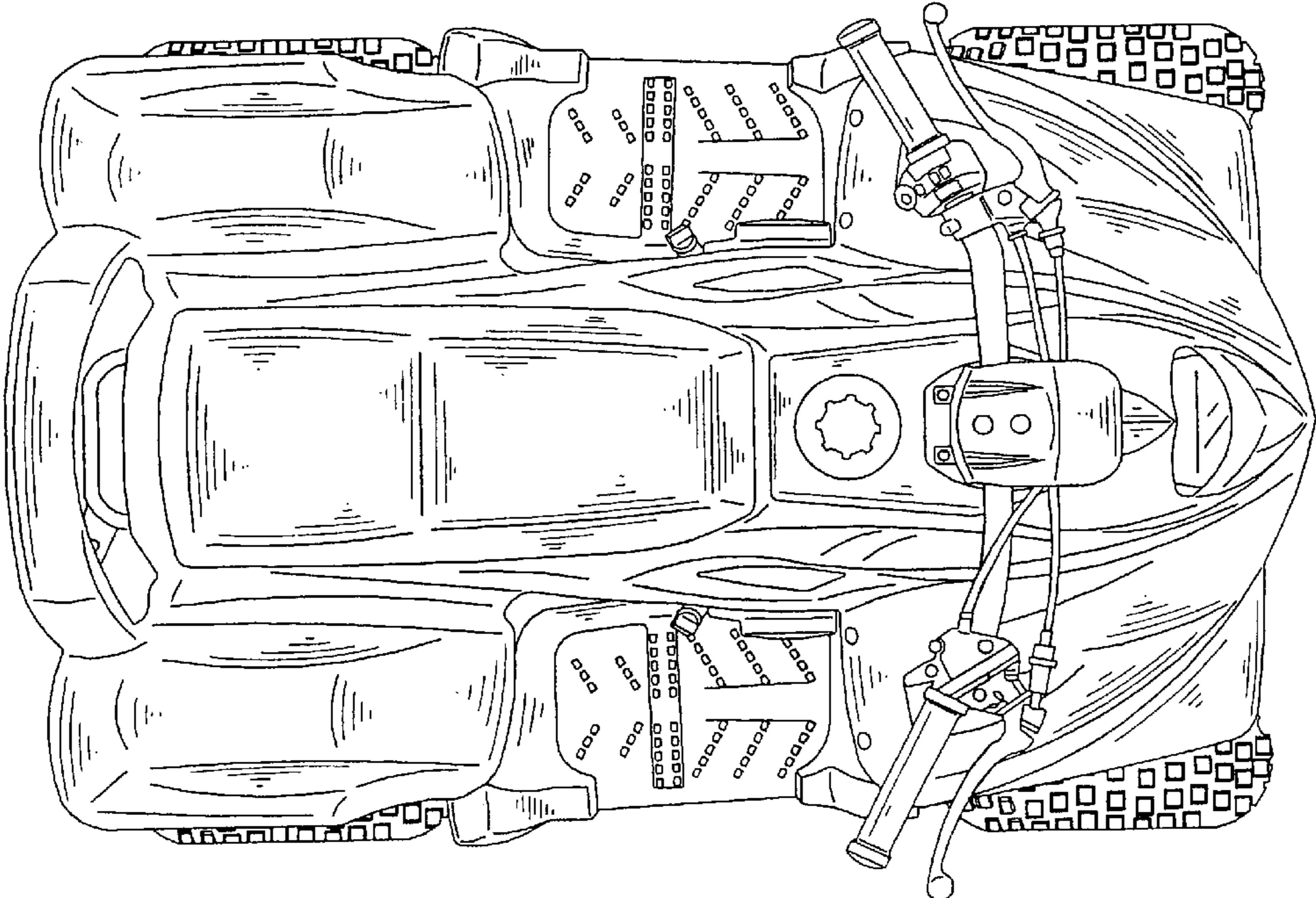

FIG. 6