



US00D511065S

(12) **United States Design Patent**  
**Pininfarina**

(10) **Patent No.:** **US D511,065 S**

(45) **Date of Patent:** **\*\* Nov. 1, 2005**

(54) **COFFEE MAKER MACHINE**

(75) **Inventor:** **Paolo Pininfarina, Cambiano (IT)**

(73) **Assignee:** **Pininfarina Extra S.r.l., Turin (IT)**

(\*\*) **Term:** **14 Years**

(21) **Appl. No.:** **29/191,834**

(22) **Filed:** **Oct. 16, 2003**

(30) **Foreign Application Priority Data**

Apr. 16, 2003 (EM) ..... 24435

(51) **LOC (8) Cl.** ..... **07-01**

(52) **U.S. Cl.** ..... **D7/309; D7/310; D7/311**

(58) **Field of Search** ..... D7/300, 309, 310,  
D7/311, 312, 306, 307, 308, 305; 99/293,  
295, 280, 281, 285, 299; 222/82, 180, 325,  
83; 392/444; 219/214, 441

(56) **References Cited**

**U.S. PATENT DOCUMENTS**

D173,909 S	*	1/1955	Munk	.....	D7/309
D185,833 S	*	8/1959	Bruntjen	.....	D7/311
D242,084 S	*	10/1976	Moreton	.....	D7/311
4,323,171 A	*	4/1982	Whirton, III et al.	.....	222/83
D442,417 S	*	5/2001	Jones et al.	.....	D7/307
D445,292 S	*	7/2001	Sowden	.....	D7/309
D473,745 S	*	4/2003	Mulle et al.	.....	D7/309

D474,366 S	*	5/2003	Hodges et al.	.....	D7/309
D477,175 S	*	7/2003	Smith	.....	D7/309
D484,734 S	*	1/2004	Drobeck	.....	D7/309
D486,346 S	*	2/2004	Jonsson	.....	D7/309
D492,878 S	*	7/2004	Nakato et al.	.....	D7/306
D495,189 S	*	8/2004	Cahen	.....	D7/309
D498,112 S	*	11/2004	Lassota et al.	.....	D7/309
D501,623 S	*	2/2005	Lin	.....	D7/309
D502,628 S	*	3/2005	Ledingham	.....	D7/309

\* cited by examiner

*Primary Examiner*—M. N. Pandozzi

(74) *Attorney, Agent, or Firm*—Sughrue Mion, PLLC

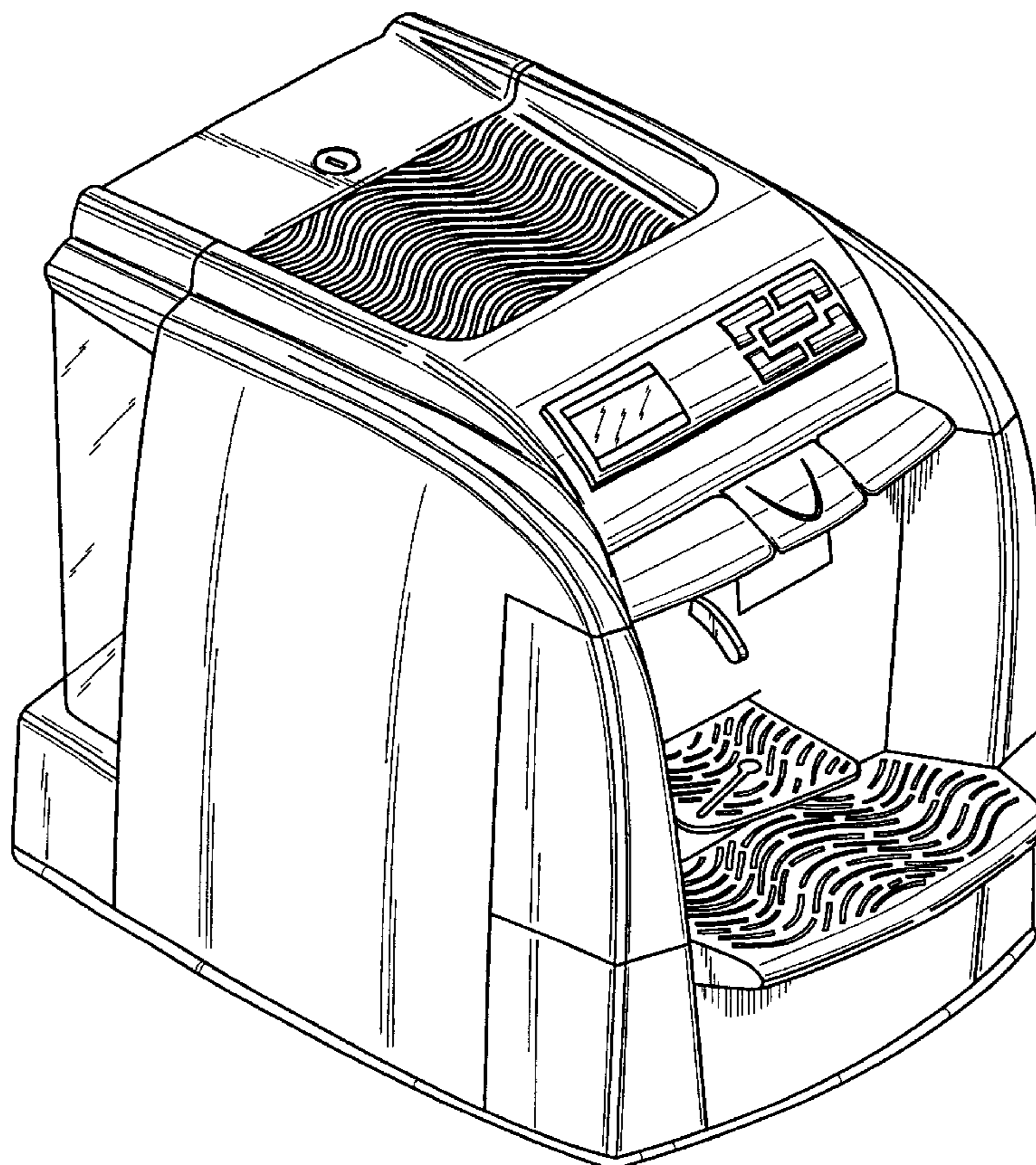
(57) **CLAIM**

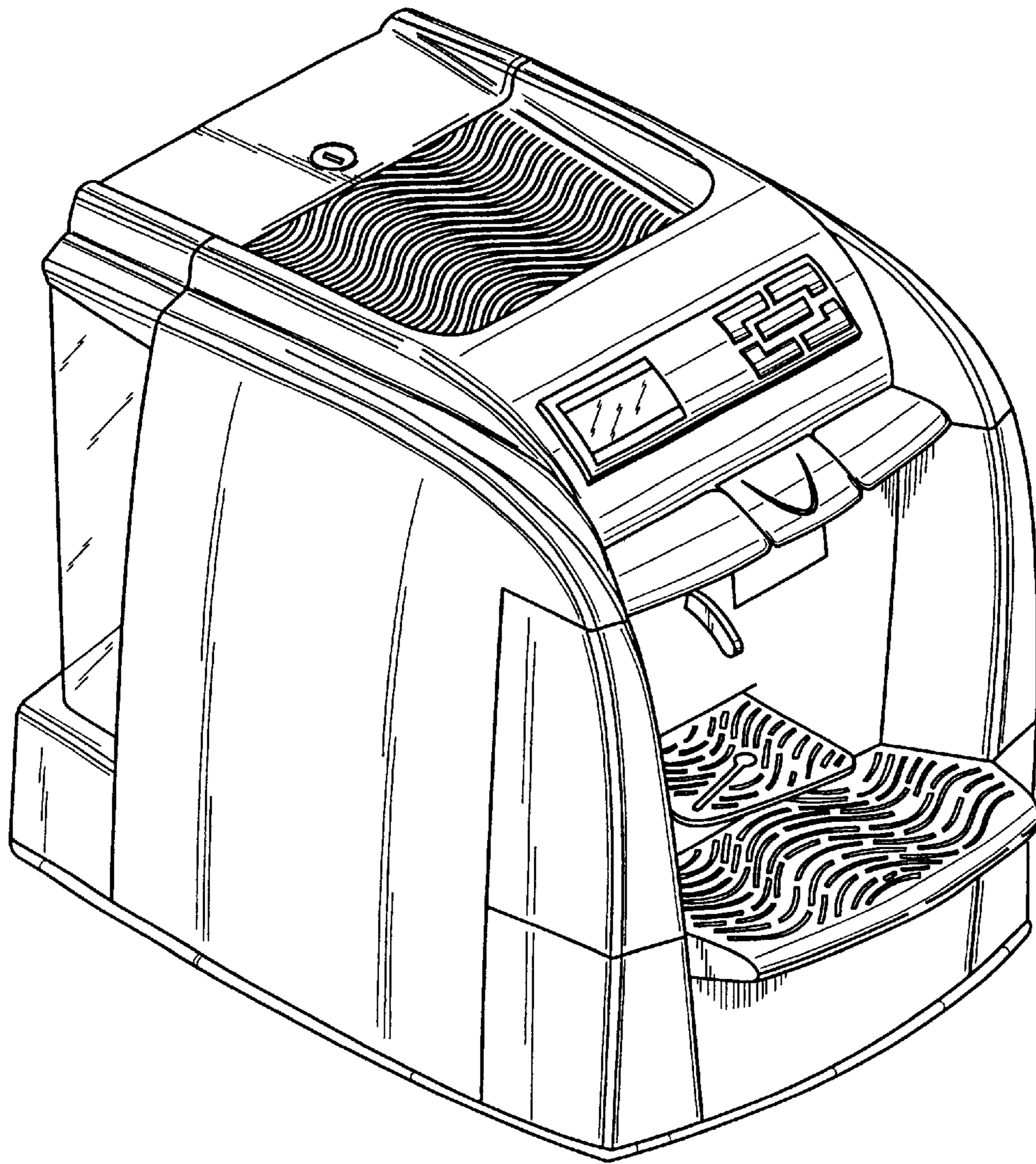
The ornamental design for a coffee maker machine, as shown and described.

**DESCRIPTION**

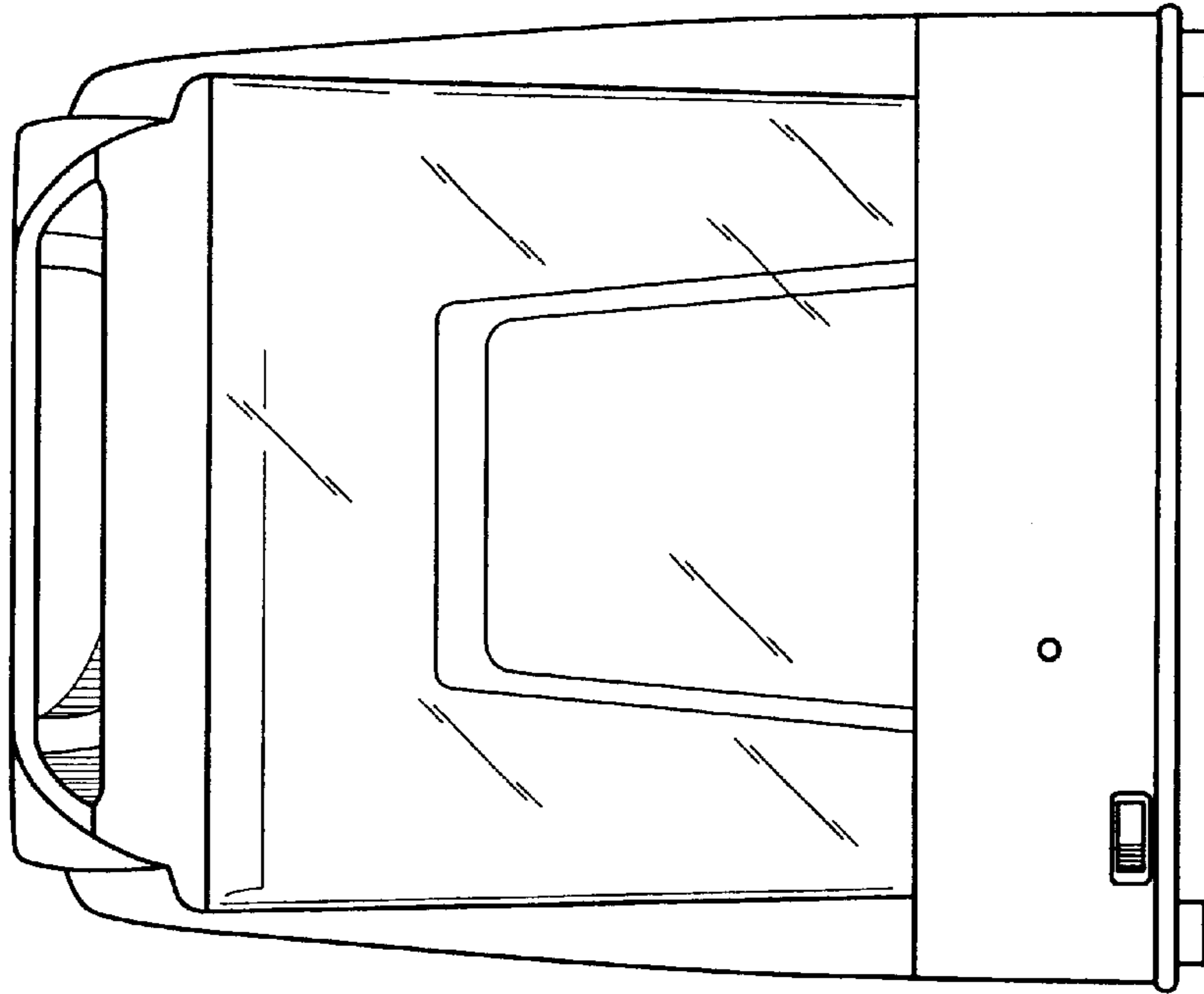
FIG. 1 is a perspective view of the top, front and left side of a coffee maker machine showing my new design; FIG. 2 is a front elevational view thereof; FIG. 3 is a rear elevational view thereof; FIG. 4 is a left side elevational view thereof; FIG. 5 is a right side elevational view thereof; FIG. 6 is a top plan view thereof; and, FIG. 7 is a bottom plan view thereof.

**1 Claim, 4 Drawing Sheets**

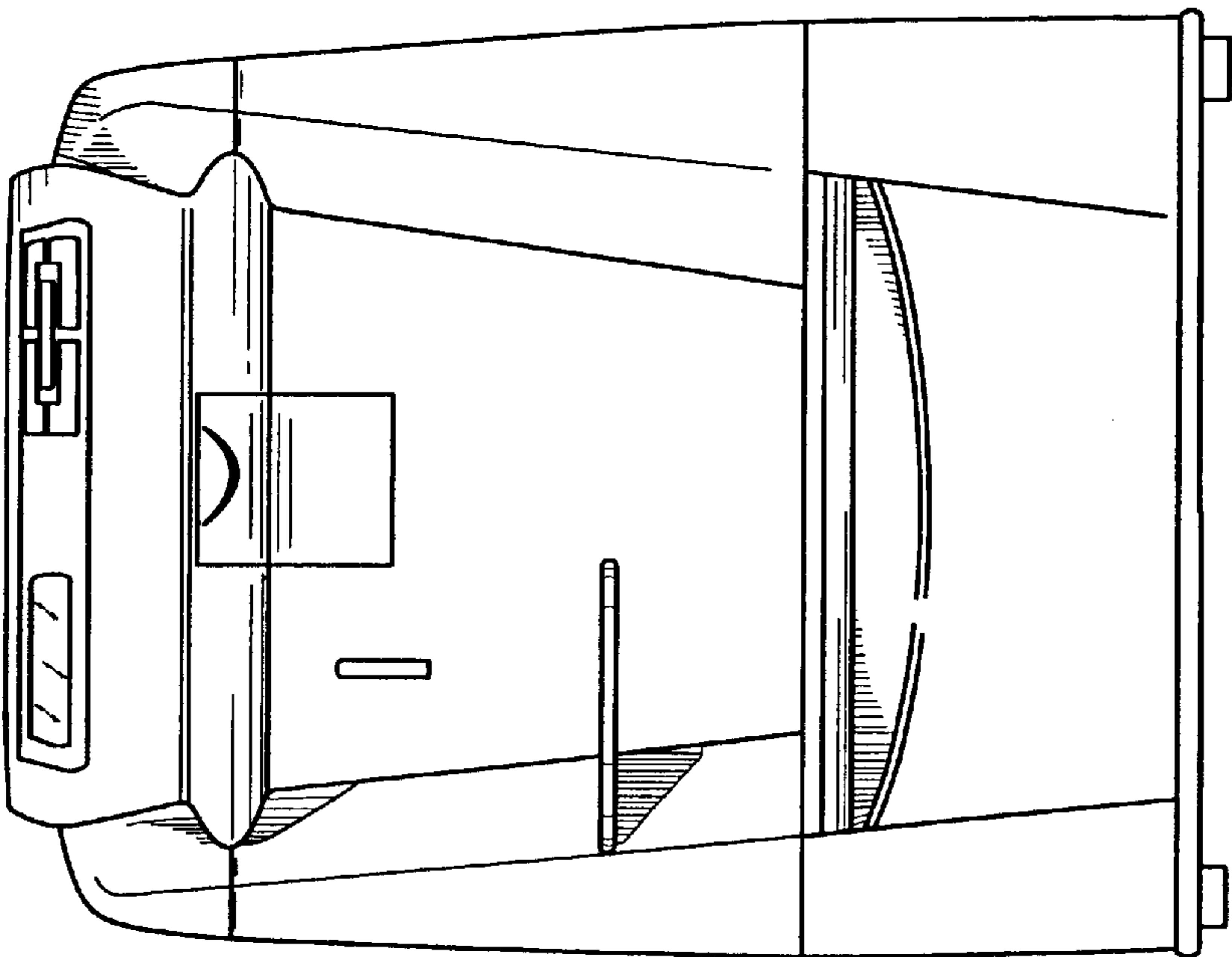




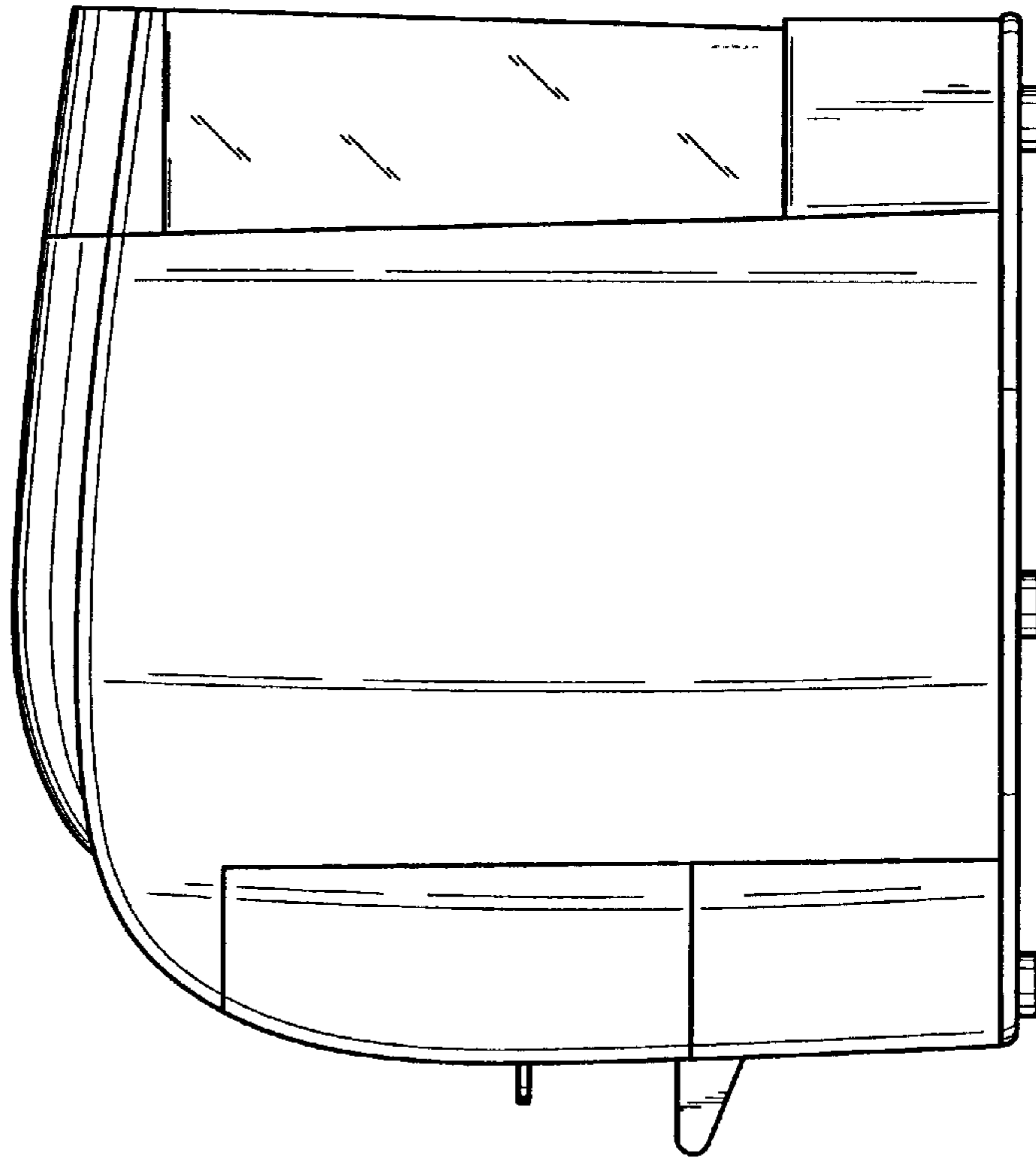
*Fig. 1*



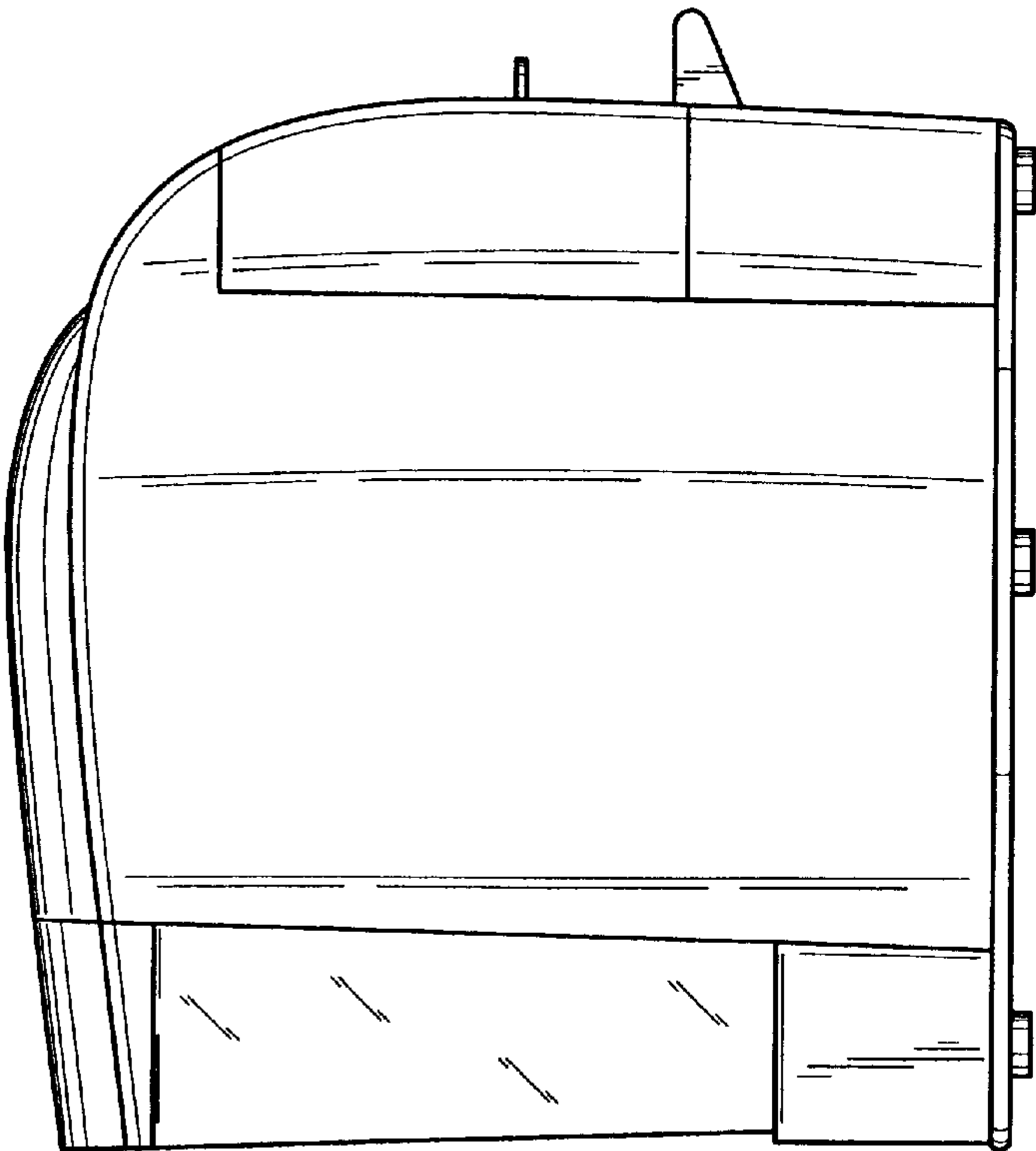
*Fig. 3*



*Fig. 2*



*Fig. 5*



*Fig. 4*

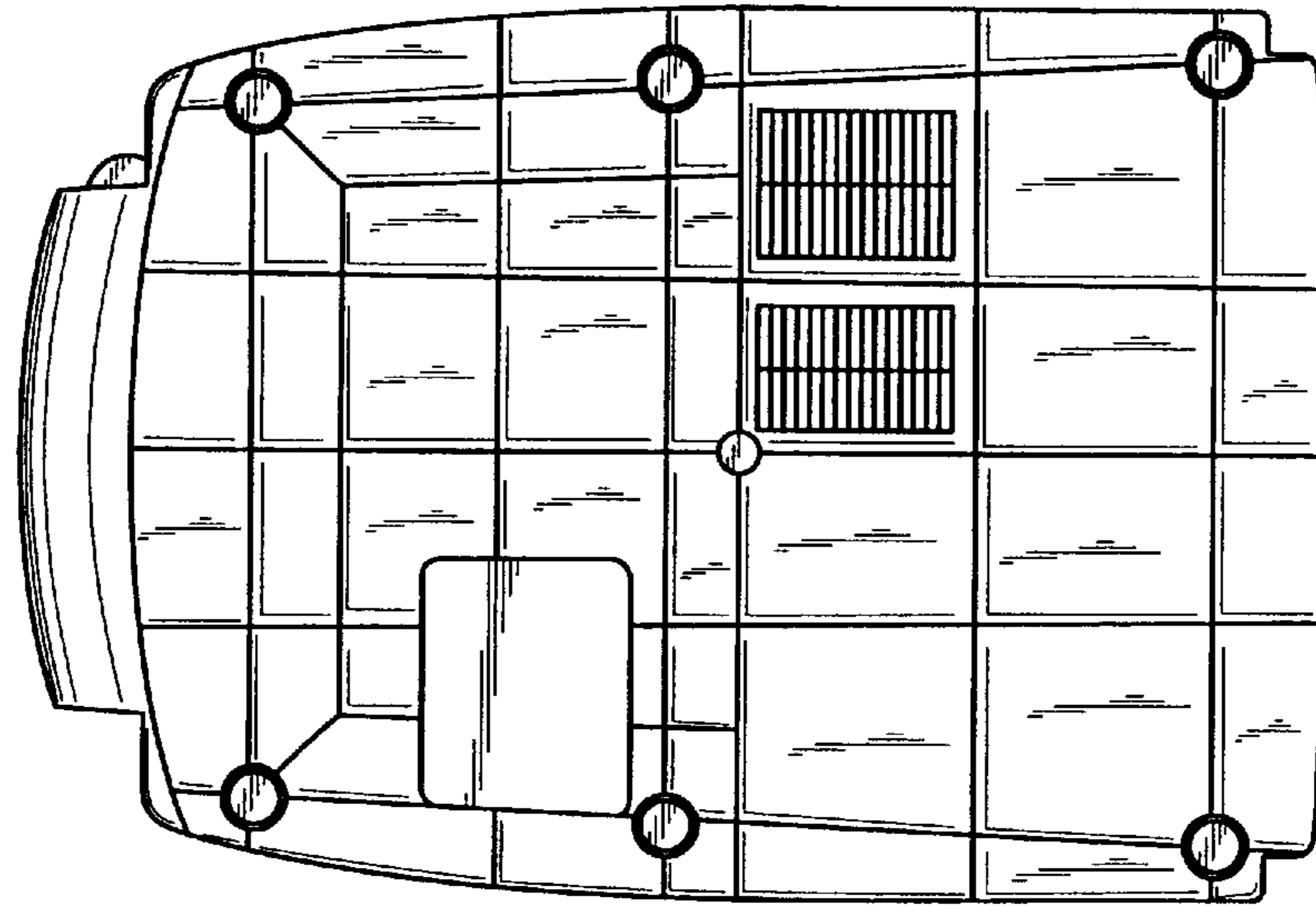


Fig. 6

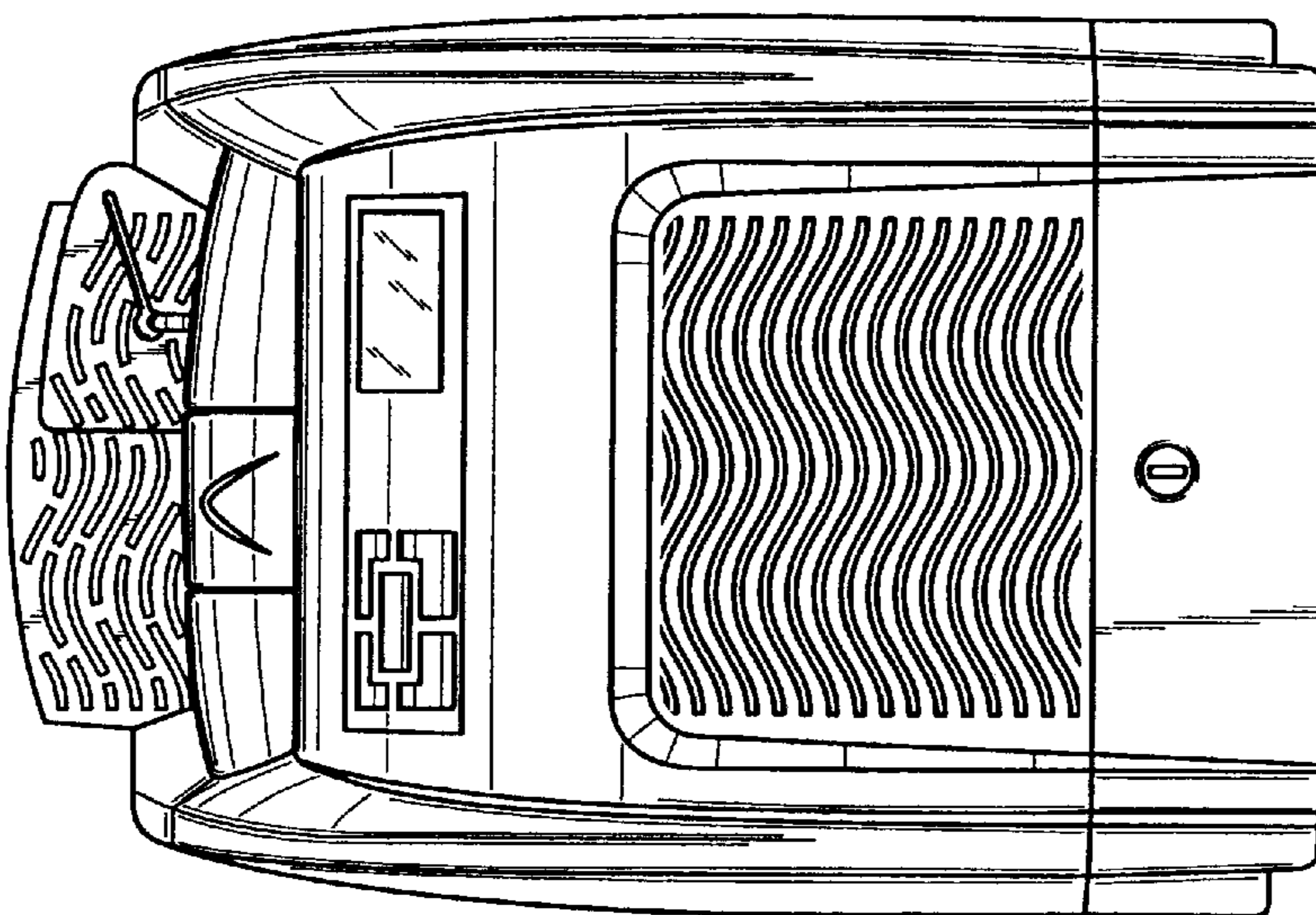


Fig. 7