



US00D510901S

(12) **United States Design Patent**
Beal et al.

(10) **Patent No.: US D510,901 S**
(45) **Date of Patent: ** Oct. 25, 2005**

(54) **MARINE VESSEL DROP-IN MODULE**

(76) Inventors: **Robert Wayne Beal**, 9600 SW. Iowa Dr., Tualatin, OR (US) 97062; **Ronald William Bosch**, 20387 Nathan La., Fairview, OR (US) 97062; **Roy Joseph Firestone**, 12682 SE. Opal Way, Clackamas, OR (US) 97015

(**) Term: **14 Years**

(21) Appl. No.: **29/206,422**

(22) Filed: **May 28, 2004**

(51) **LOC (8) Cl.** **12-06**

(52) **U.S. Cl.** **D12/317**

(58) **Field of Search** D12/300-318;
124/3, 4; D22/100, 108, 112, 113; 89/1.8,
1.801, 1.804, 1.806, 1.813, 1.814, 1.815,
1.816

(56) **References Cited**

U.S. PATENT DOCUMENTS

1,959,737 A * 5/1934 Rigsby 124/3

4,471,684 A * 9/1984 Johnson et al. 89/1.815
5,042,358 A * 8/1991 Kuriwa 89/1.8
5,194,688 A * 3/1993 Piesik 89/1.816
5,974,939 A * 11/1999 Deel 89/1.8

* cited by examiner

Primary Examiner—Holly Baynham
Assistant Examiner—Cynthia M. Chin
(74) *Attorney, Agent, or Firm*—Ingrid McTaggart

(57) **CLAIM**

The ornamental design for a marine vessel drop-in module, as shown and described.

DESCRIPTION

FIG. 1 is a front perspective view of the marine vessel drop-in module;
FIG. 2 is a left side elevational view thereof, wherein the right side elevational view is a mirror image thereof;
FIG. 3 is a top plan view thereof;
FIG. 4 is a bottom plan view thereof;
FIG. 5 is a rear elevational view thereof; and,
FIG. 6 is a front elevational view thereof.

1 Claim, 4 Drawing Sheets

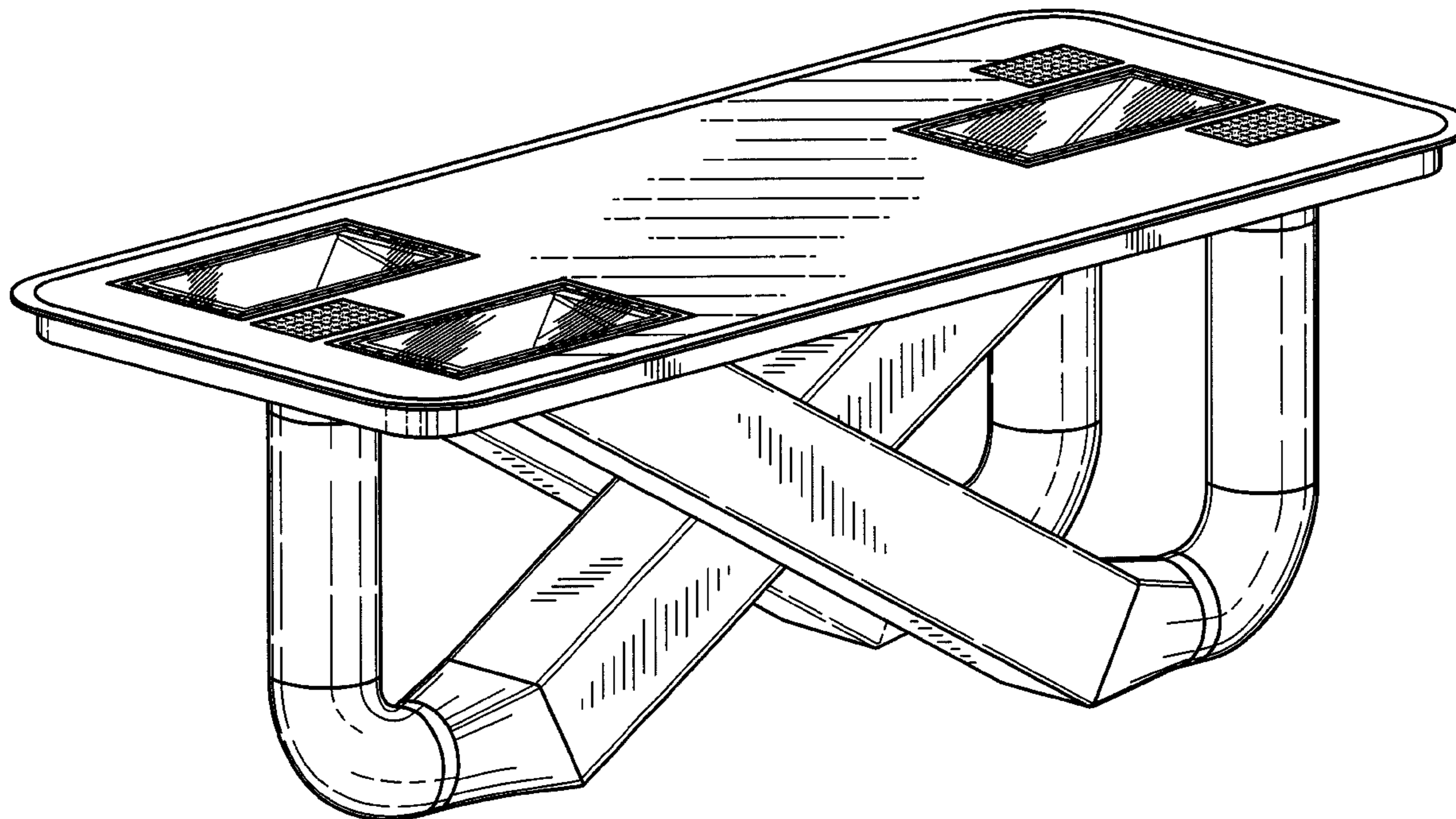

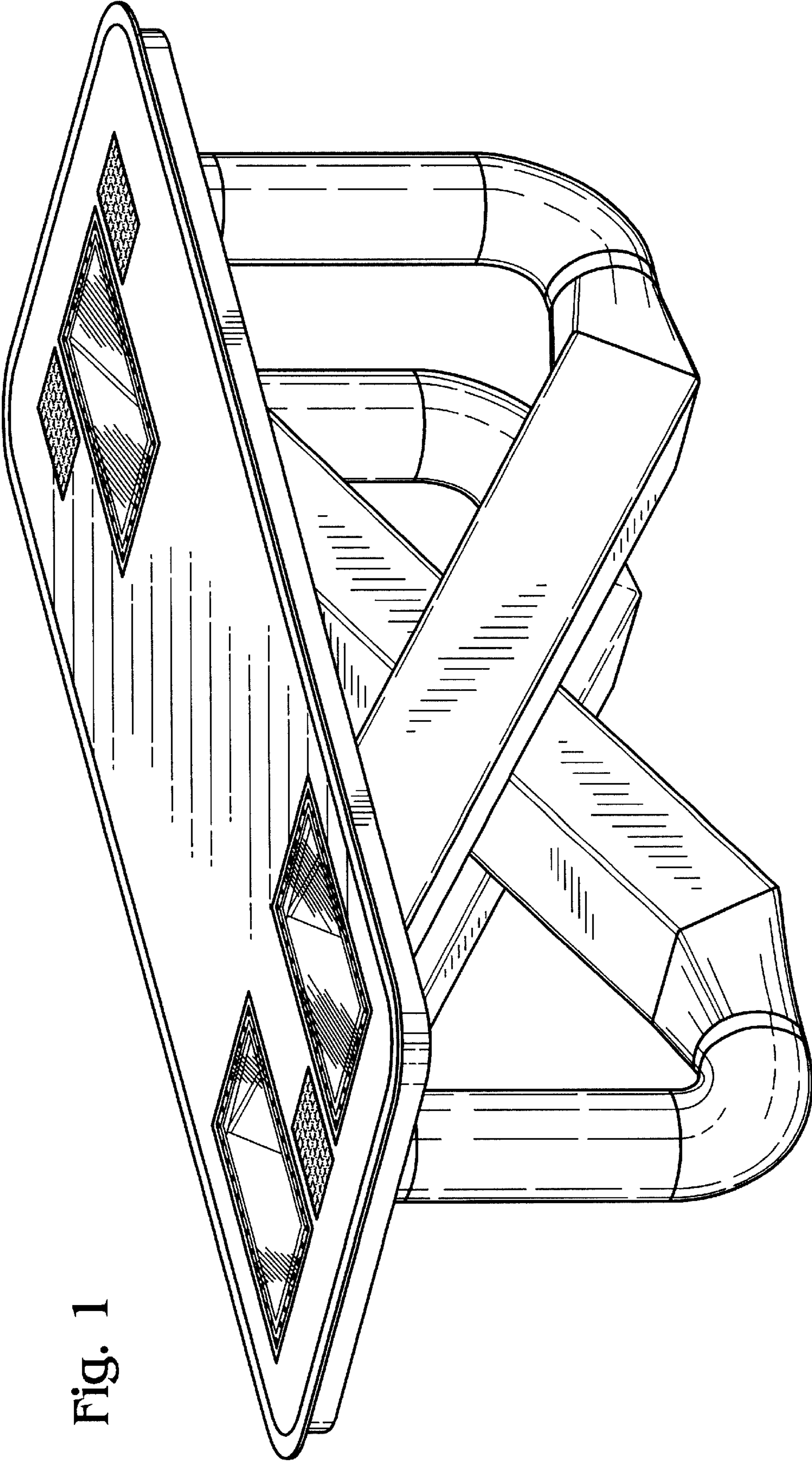
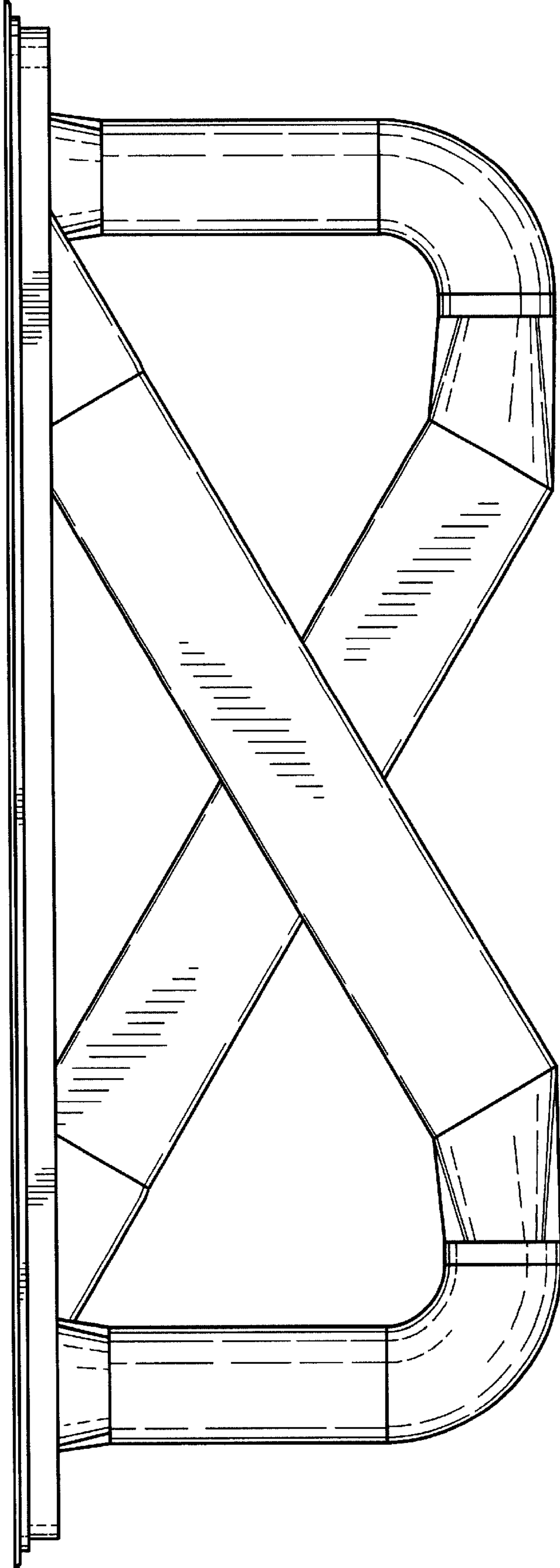

Fig. 1

Fig. 2



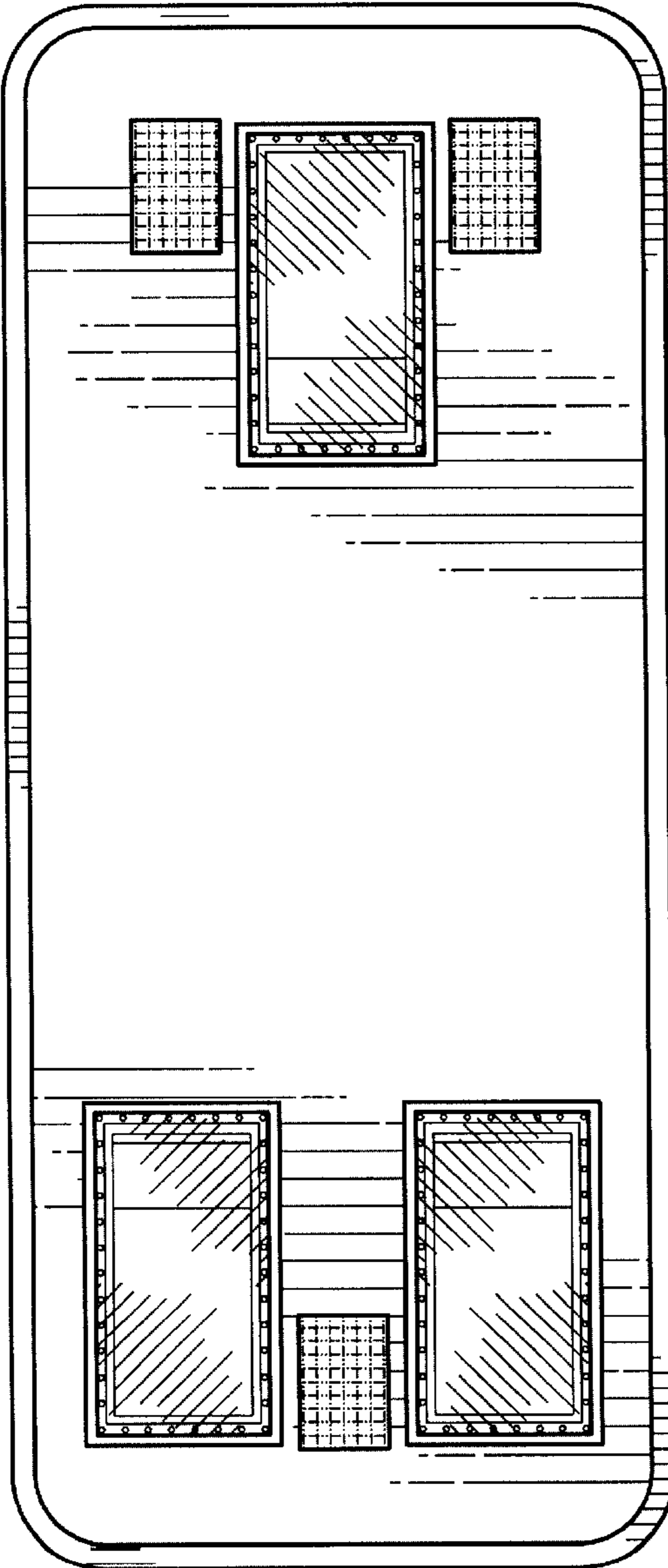

Fig. 3

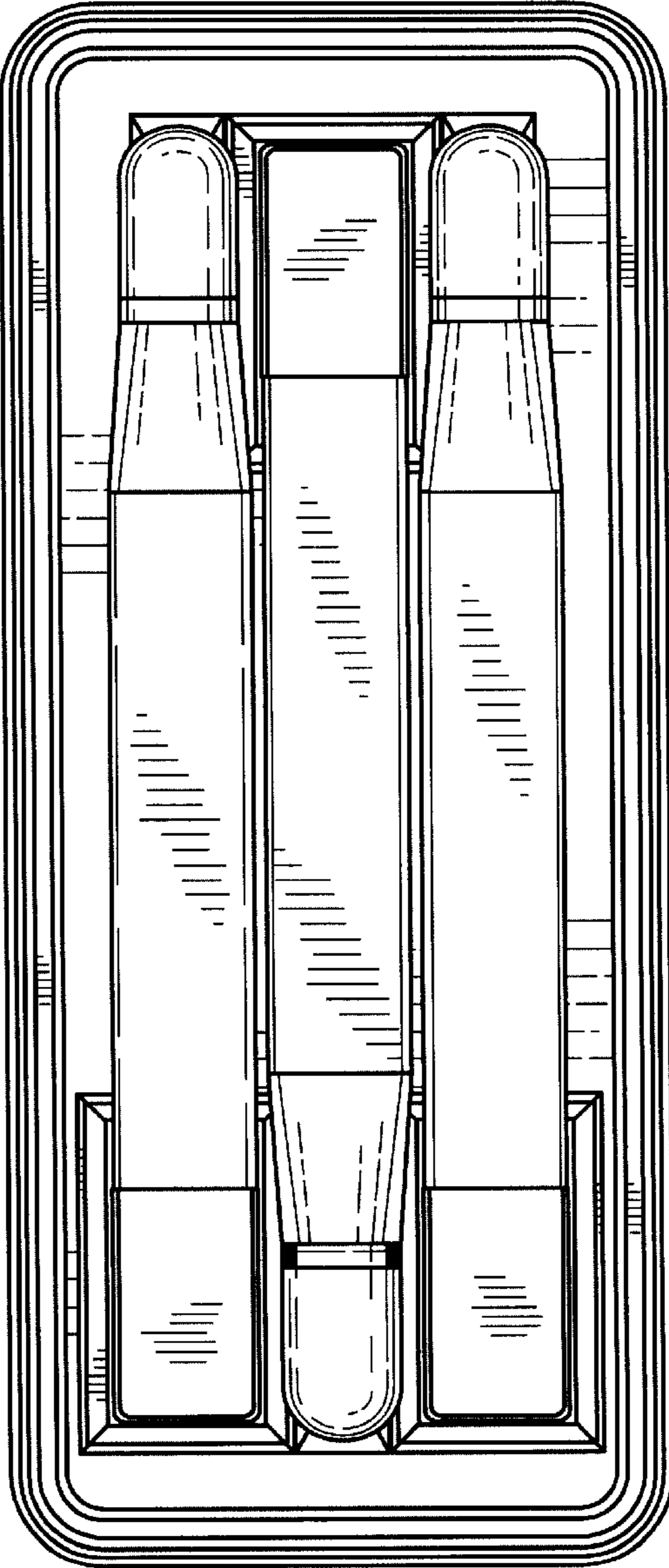

Fig. 4

Fig. 5

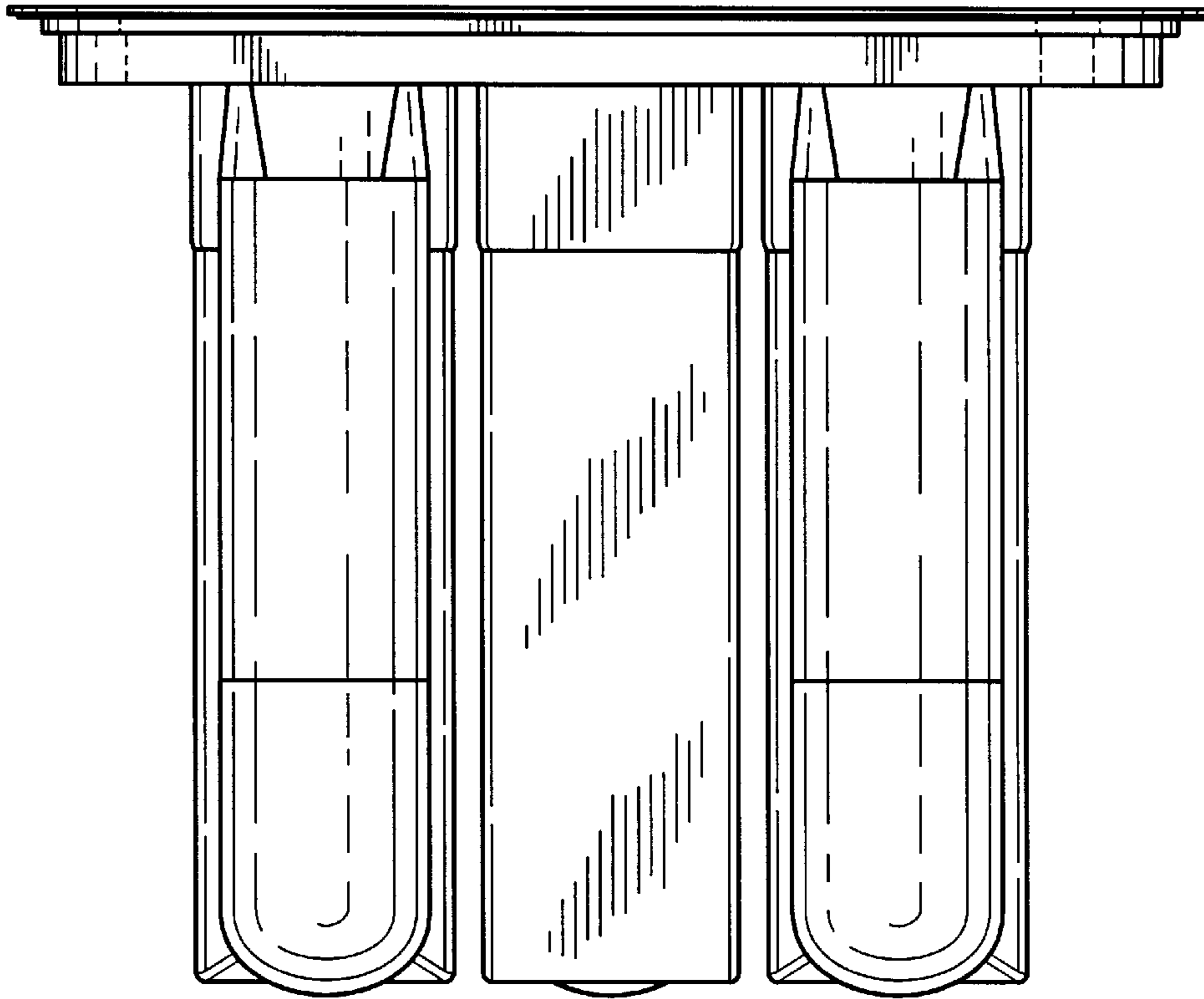

Fig. 6

