



US00D510875S

(12) **United States Design Patent** (10) **Patent No.:** **US D510,875 S**
Shurman (45) **Date of Patent:** **** Oct. 25, 2005**

- (54) **DISPENSING CONTAINER**
- (75) Inventor: **Anthony Craig Shurman**, Westfield, NJ (US)
- (73) Assignee: **Yosha! Enterprises**, Westfield, NJ (US)
- (**) Term: **14 Years**
- (21) Appl. No.: **29/219,252**
- (22) Filed: **Dec. 14, 2004**

- 5,878,875 A 3/1999 Leong
- 5,918,734 A 7/1999 Devens et al.
- 6,119,852 A 9/2000 Focke et al.
- D432,263 S 10/2000 Issa
- 6,223,891 B1 5/2001 Devens et al.

OTHER PUBLICATIONS

- (front view) "Breath Savers Cool Blasts", Nabisco Inc., www.CANDYSTAND.com.
- (back view) "Breath Savers Cool Blasts", Nabisco Inc., www.CANDYSTAND.com.
- (side view) "Breath Savers Cool Blasts", Nabisco Inc., www.CANDYSTAND.com.
- (front view) "Certs Powerful Mints", 1996, Warner-Lambert Co., www.certs.com.
- (back view) "Certs Powerful Mints", 1996, Warner-Lambert Co., www.certs.com.
- (side view) "Certs Powerful Mints", 1996, Warner-Lambert Co., www.certs.com.
- (front view) "Café Select After Coffee Mints", 2002, Ovalette Brands LLC., www.7-Eleven.com.
- (back view) "Café Select After Cofee Mints", 2002, Ovalette Brands LLC., www.7-Eleven.com.

Related U.S. Application Data

- (62) Division of application No. 29/190,361, filed on Sep. 19, 2003, now Pat. No. Des. 501,136.
- (51) **LOC (8) Cl.** **09-03**
- (52) **U.S. Cl.** **D9/733**
- (58) **Field of Search** D9/730, 733, 735, D9/414, 417, 424, 430, 431, 432; D19/65, 67, 69; 206/37, 527; 221/282; 222/153.01, 173, 175, 323-324, 372, 465.1

(56) **References Cited**

U.S. PATENT DOCUMENTS

- 724,667 A 4/1903 Cornell
- 2,727,547 A 12/1955 Moon, 3rd
- 2,809,747 A 10/1957 Fowler, Jr.
- 3,472,362 A 10/1969 Shinoda
- 3,915,295 A 10/1975 Morrison
- 4,046,252 A 9/1977 Korby et al.
- 4,144,985 A 3/1979 Kinslow
- 4,517,994 A 5/1985 Endelson
- 4,538,731 A 9/1985 Cillario
- 4,804,113 A 2/1989 Ciaccio
- 4,852,729 A 8/1989 Conte
- 4,989,728 A 2/1991 Neyret et al.
- 5,088,684 A 2/1992 Torras et al.
- 5,096,057 A 3/1992 Yoo
- 5,353,956 A 10/1994 Wilson
- 5,482,157 A 1/1996 Kim
- 5,558,217 A 9/1996 Focke et al.
- 5,630,503 A 5/1997 Rhodes et al.
- 5,636,732 A 6/1997 Gilels et al.

(Continued)

Primary Examiner—Stella Reid
Assistant Examiner—Daniel Bui
(74) *Attorney, Agent, or Firm*—Baker & McKenzie LLP

(57) **CLAIM**

The ornamental design for a dispensing container, as shown.

DESCRIPTION

FIG. 1 is a top and rear perspective view of a dispensing container, showing my new design;
FIG. 2 is top and front perspective view thereof;
FIG. 3 is a right side elevation view thereof;
FIG. 4 is a rear elevation view thereof;
FIG. 5 is a left side elevation view thereof;
FIG. 6 is a front elevation view thereof;
FIG. 7 is a top elevation view thereof; and,
FIG. 8 is a bottom elevation view thereof.

1 Claim, 3 Drawing Sheets

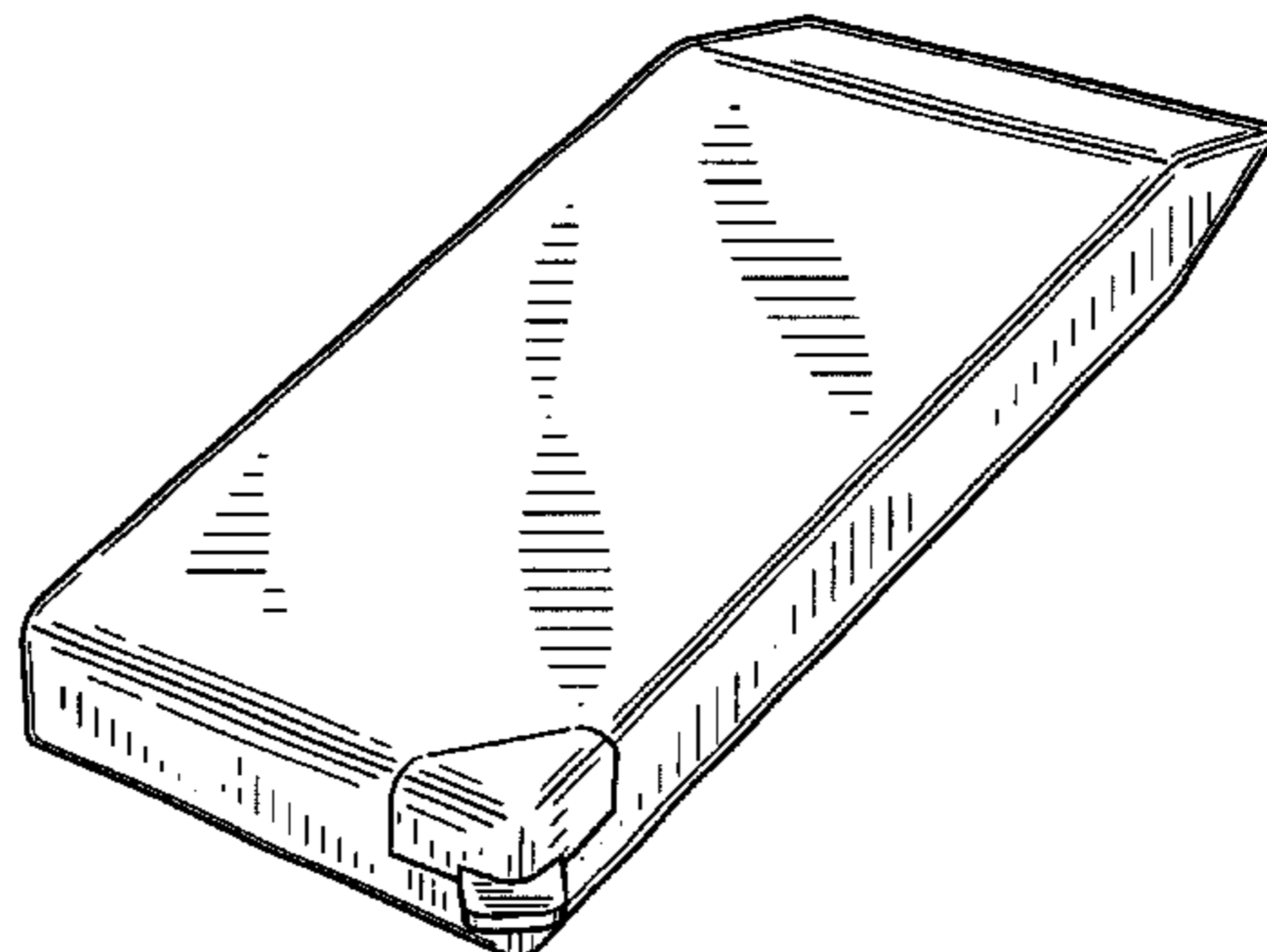

OTHER PUBLICATIONS

(side view) “Café Select After Coffee Mints”, 2002, Ovalette Brands LLC., www.7-Eleven.com.

(front view) “Winterfresh Thin Ice”, 2002, Wm. Wrigley Jr. Company.

(side view) “Winterfresh Thin Ice”, 2002, Wm. Wrigley Jr. Company.

(front view) “Cool Mint Listerine PocketPaks”, 2001, PFIZER, www.prodhelp.com.

(back view) “Cool Mint Listerine PocketPaks”, 2001, PFIZER, www.prodhelp.com.

(side view) “Cool Mint Listerine PocketPaks”, 2001, PFIZER, www.prodhelp.com.

(front view) “Myntz! Instastripz”, 2001, Myntz! Brands, www.myntz.com.

(back view) “Myntz! Instastripz”, Myntz! Brands, www.myntz.com.

(side view) “Myntz! Instastripz”, 2001, Myntz! Brands, www.myntz.com.

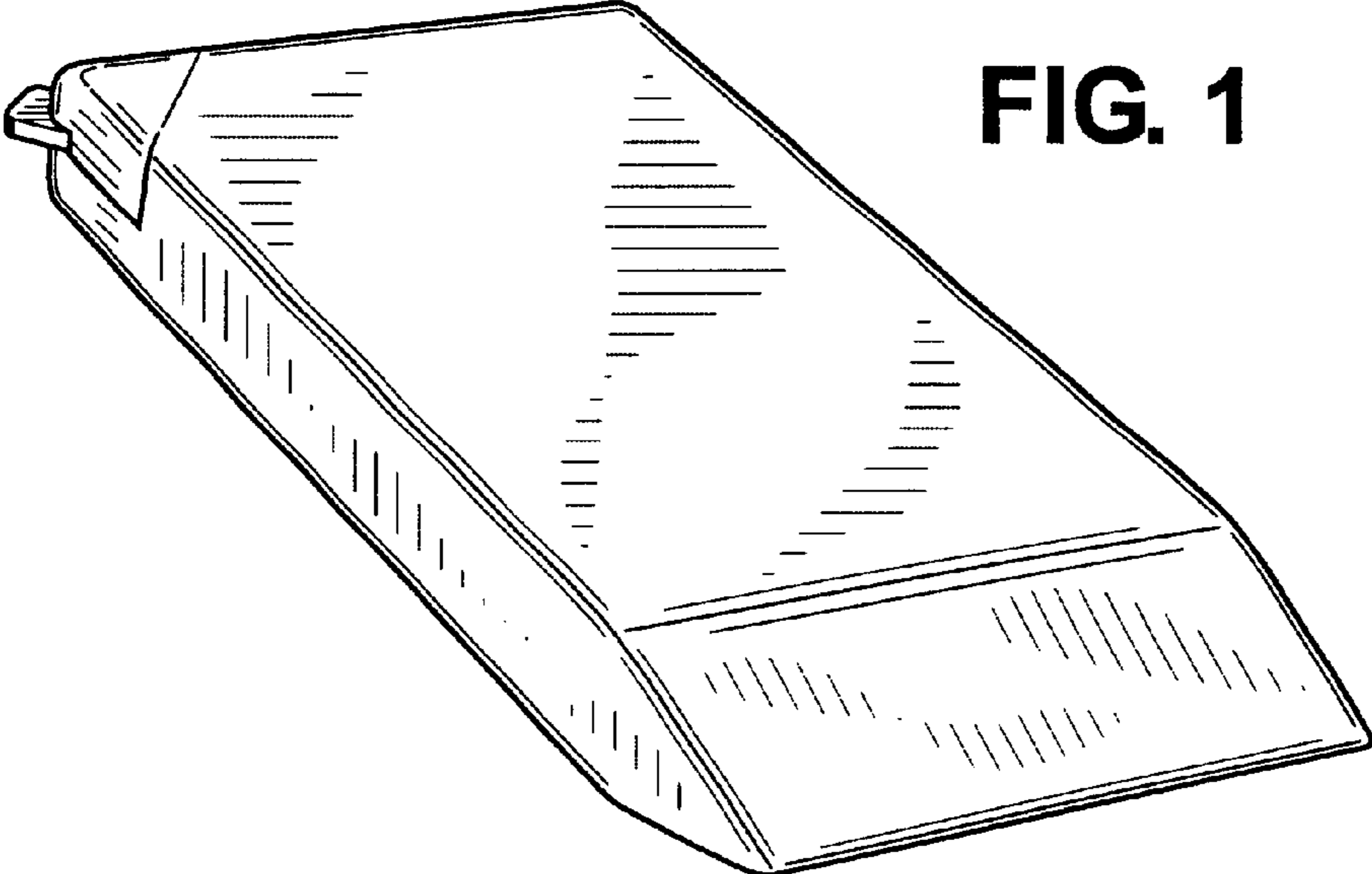

FIG. 1

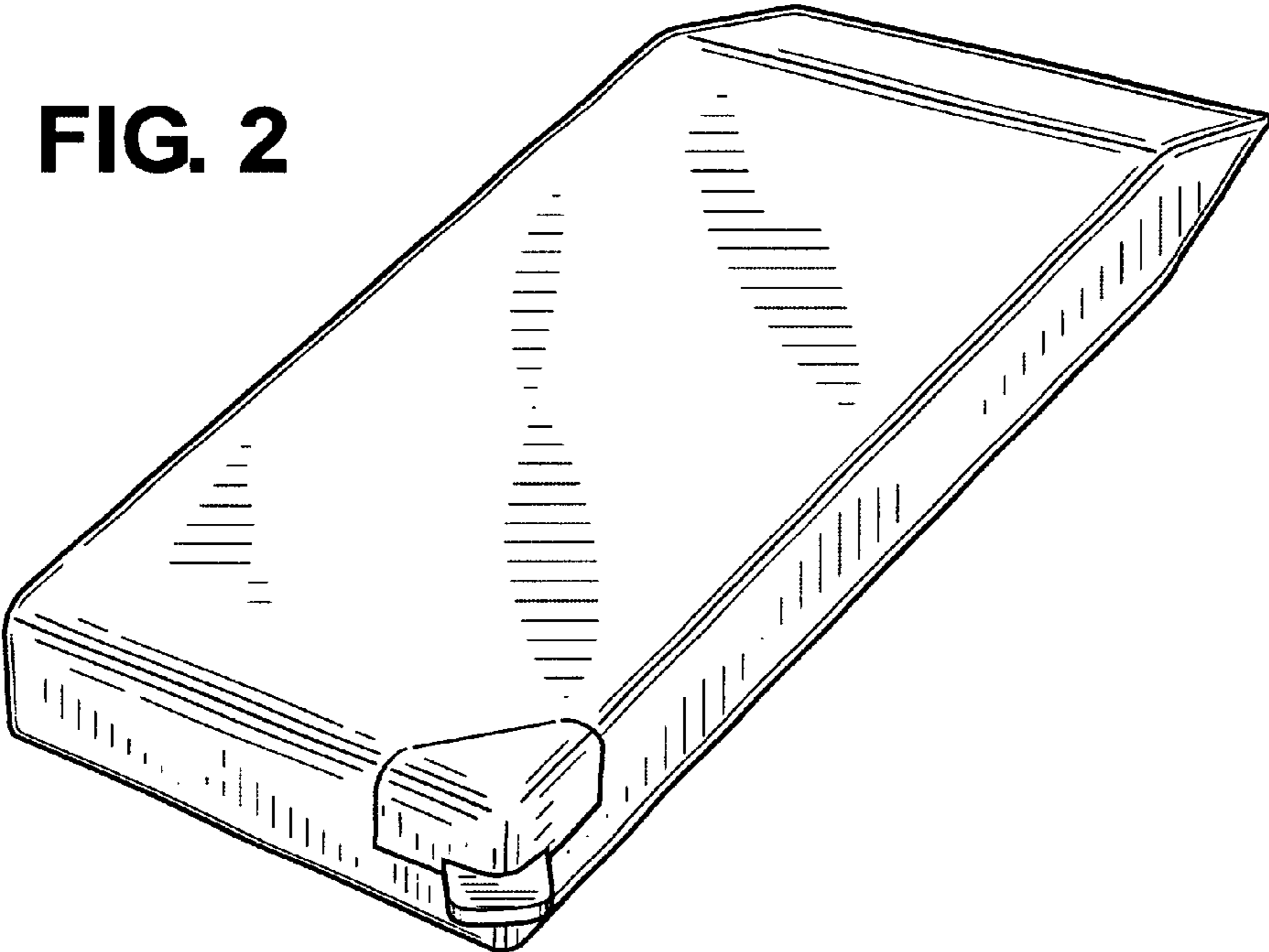

FIG. 2

FIG. 3



FIG. 4

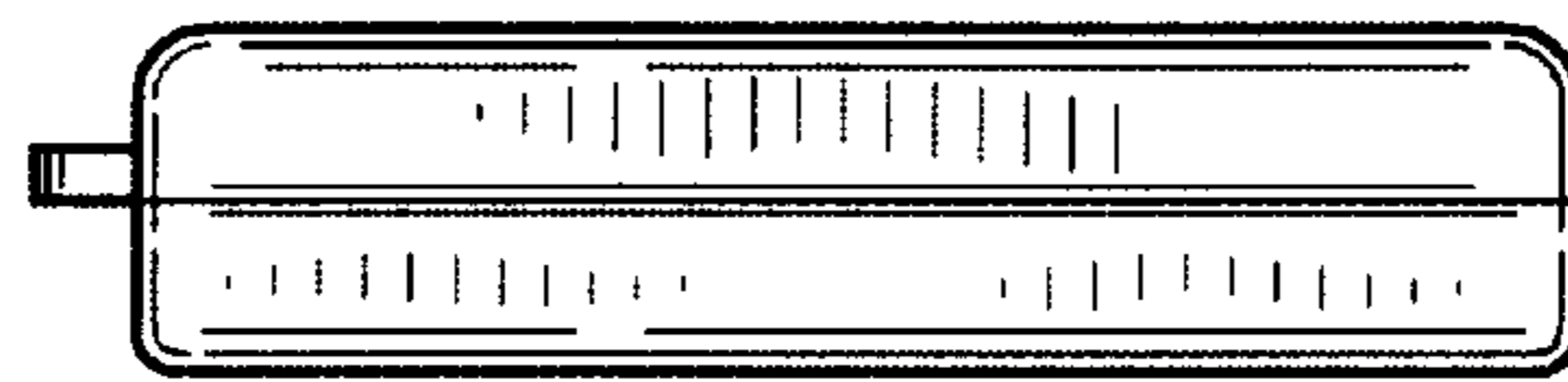

FIG. 5

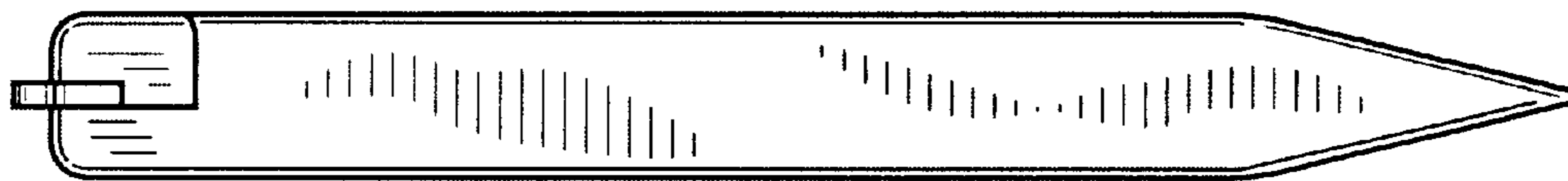

FIG. 6

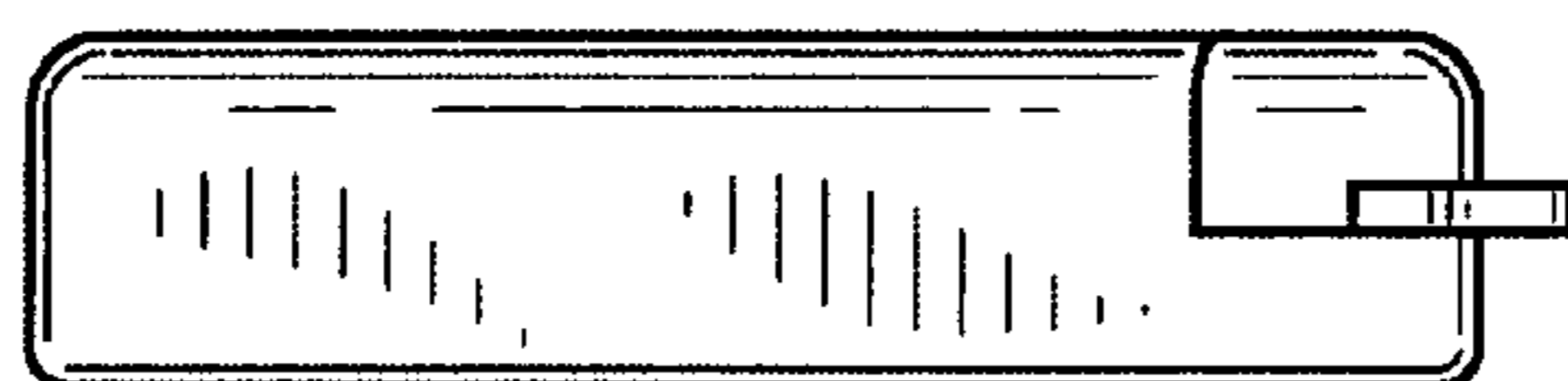

FIG. 7

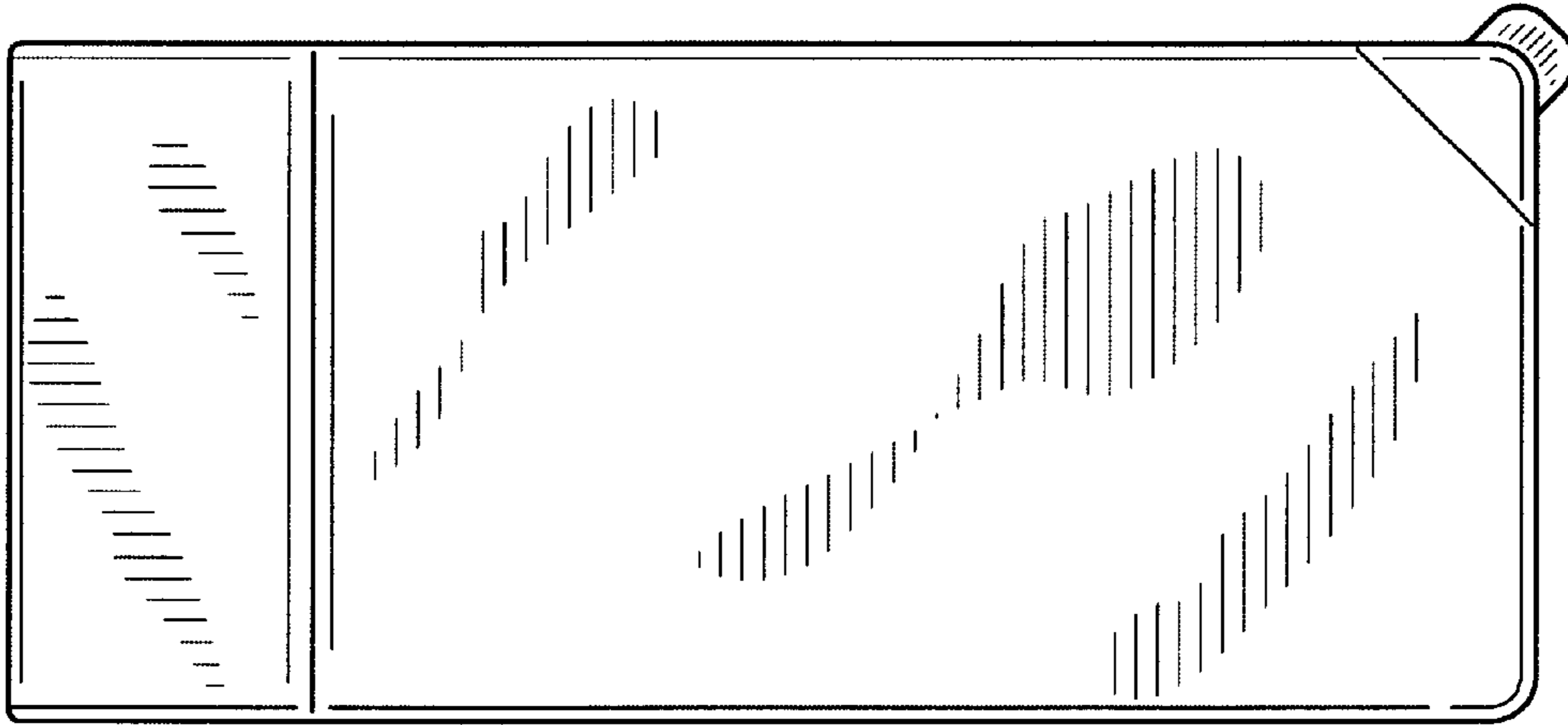

FIG. 8

