



US00D510697S

(12) **United States Design Patent**  
**Gaster**

(10) **Patent No.:** **US D510,697 S**

(45) **Date of Patent:** **\*\* Oct. 18, 2005**

(54) **PIVOTAL STRAP CLAMP FOR  
RESTRAINING A VEHICLE WHEEL**

(76) **Inventor:** **Ivan Gaster**, 201 Richard Ct., Union,  
OH (US) 45322

(\*\*) **Term:** **14 Years**

(21) **Appl. No.:** **29/188,923**

(22) **Filed:** **Aug. 27, 2003**

(51) **LOC (8) Cl.** ..... **08-08**

(52) **U.S. Cl.** ..... **D8/383; D8/395**

(58) **Field of Search** ..... D8/44, 52, 54,  
D8/383, 394, 395; D12/51; 24/327, 331,  
338, 350, 459; 248/49, 62, 74.1-74.4

(56) **References Cited**

**U.S. PATENT DOCUMENTS**

697,127 A *	4/1902	Bogendoerfer	431/35
900,034 A *	9/1908	Newton	24/507
3,126,600 A *	3/1964	De Marre	24/301
3,705,442 A *	12/1972	Sygnator	24/573.09
4,960,353 A	10/1990	Thorndyke	
D319,958 S *	9/1991	Fletcher	D8/52

D328,840 S *	8/1992	Jensen	D8/44
5,619,177 A *	4/1997	Johnson et al.	337/140
6,171,037 B1	1/2001	Andre	
D491,434 S *	6/2004	Noniewicz	D8/58

\* cited by examiner

*Primary Examiner*—Louis S. Zarfaz

*Assistant Examiner*—John Windmuller

(74) *Attorney, Agent, or Firm*—Jacox, Meckstroth & Jenkins

(57) **CLAIM**

The ornamental design of a pivotal strap clamp for restraining a vehicle wheel, as shown and described.

**DESCRIPTION**

FIG. 1 is a perspective view of a pivotal strap clamp for restraining a vehicle wheel showing my new design; FIG. 2 is a front elevational view thereof, the rear elevational view being a mirror image; FIG. 3 is a top plan view thereof; FIG. 4 is a bottom plan view thereof; FIG. 5 is a right side elevational view thereof; and, FIG. 6 is a left side elevational view thereof.

**1 Claim, 2 Drawing Sheets**

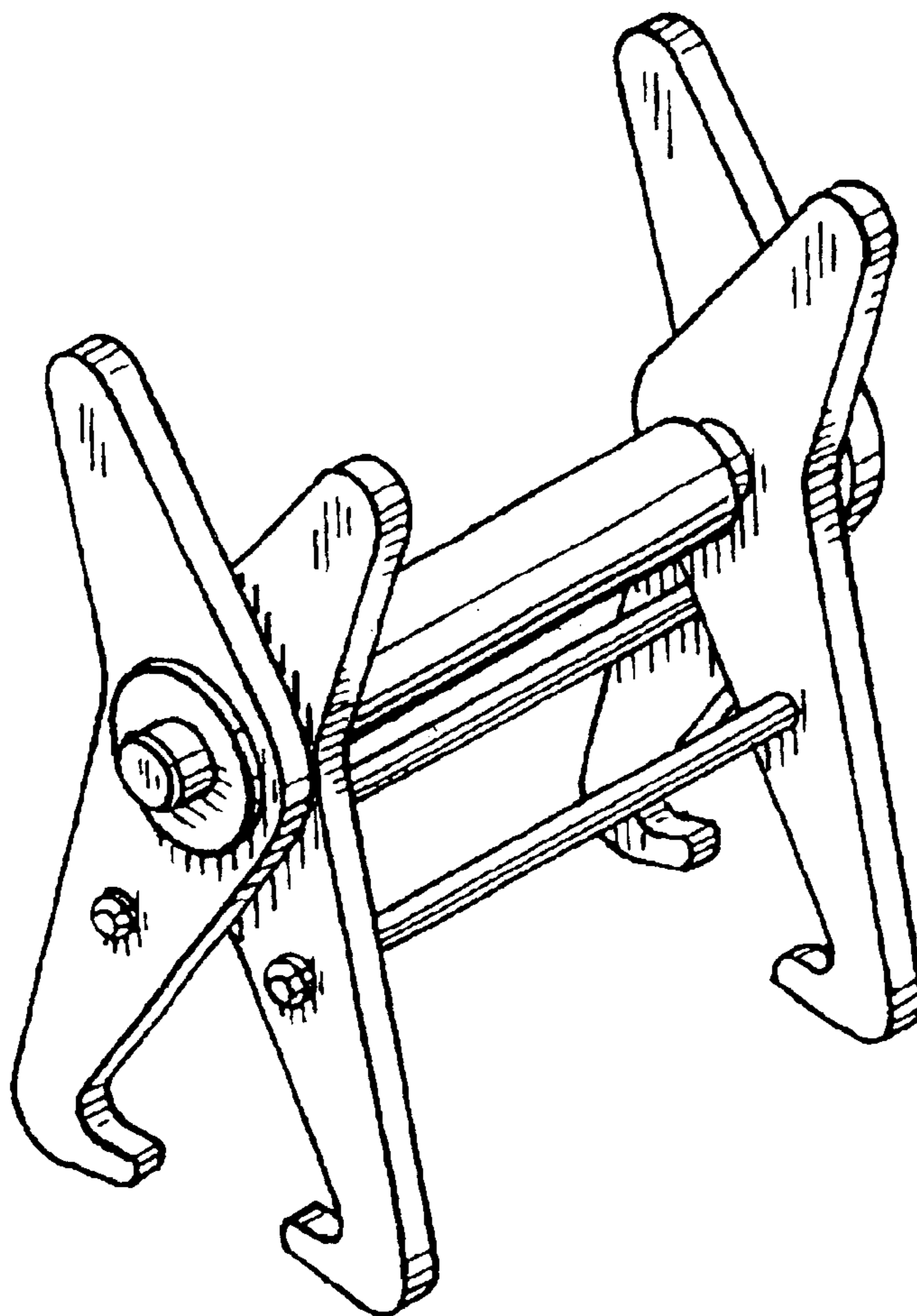

FIG-1

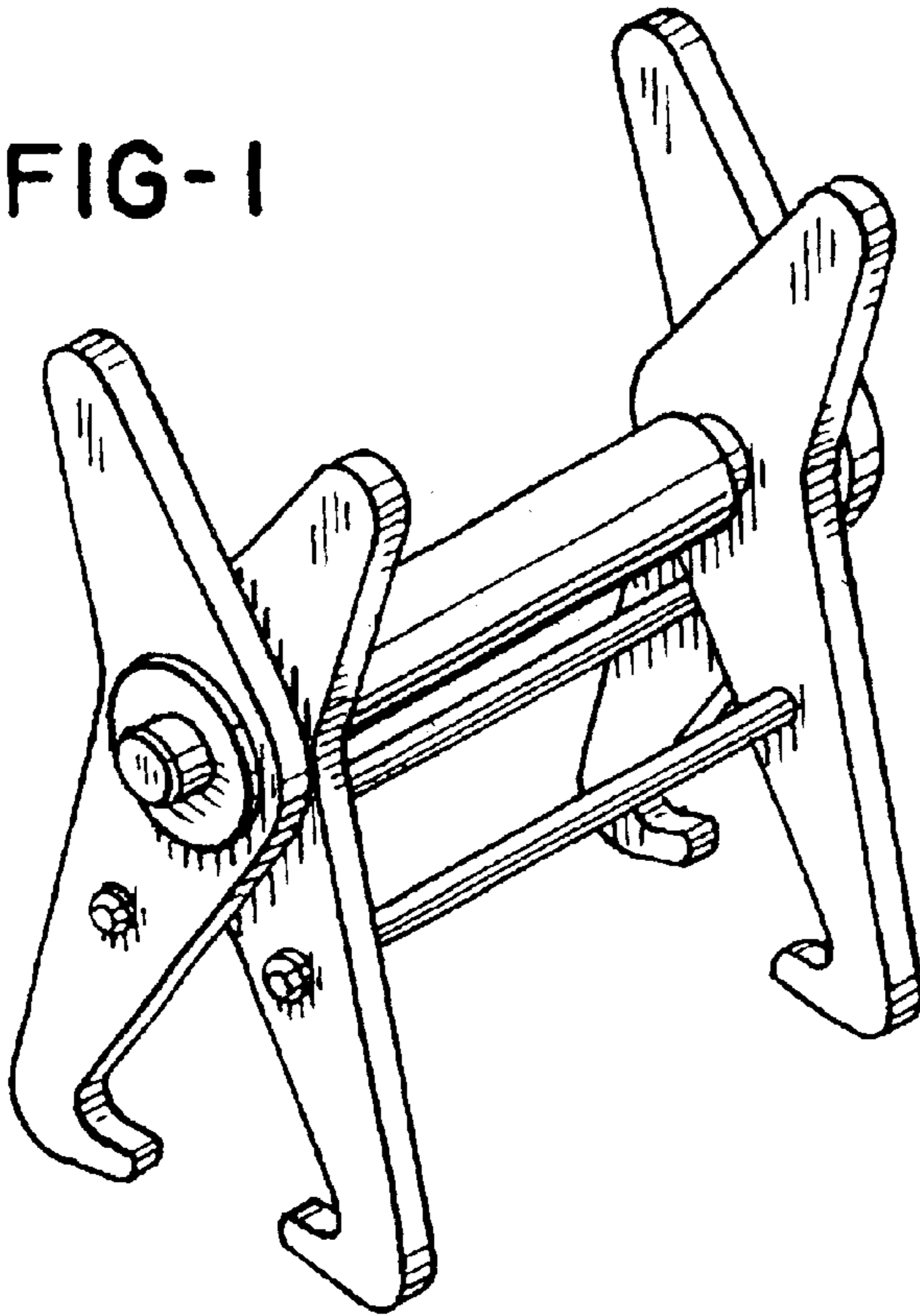

FIG-2

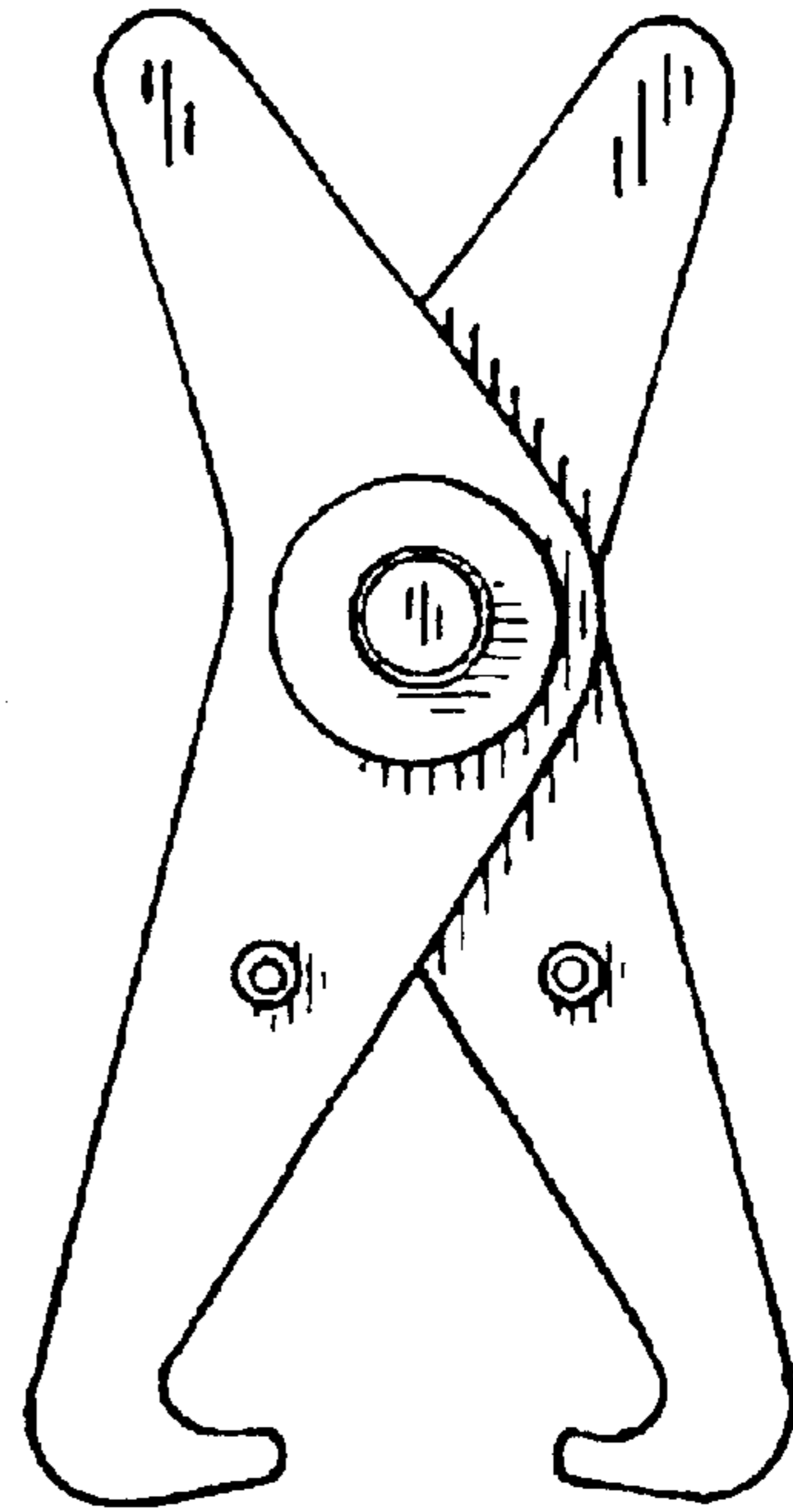

FIG-3

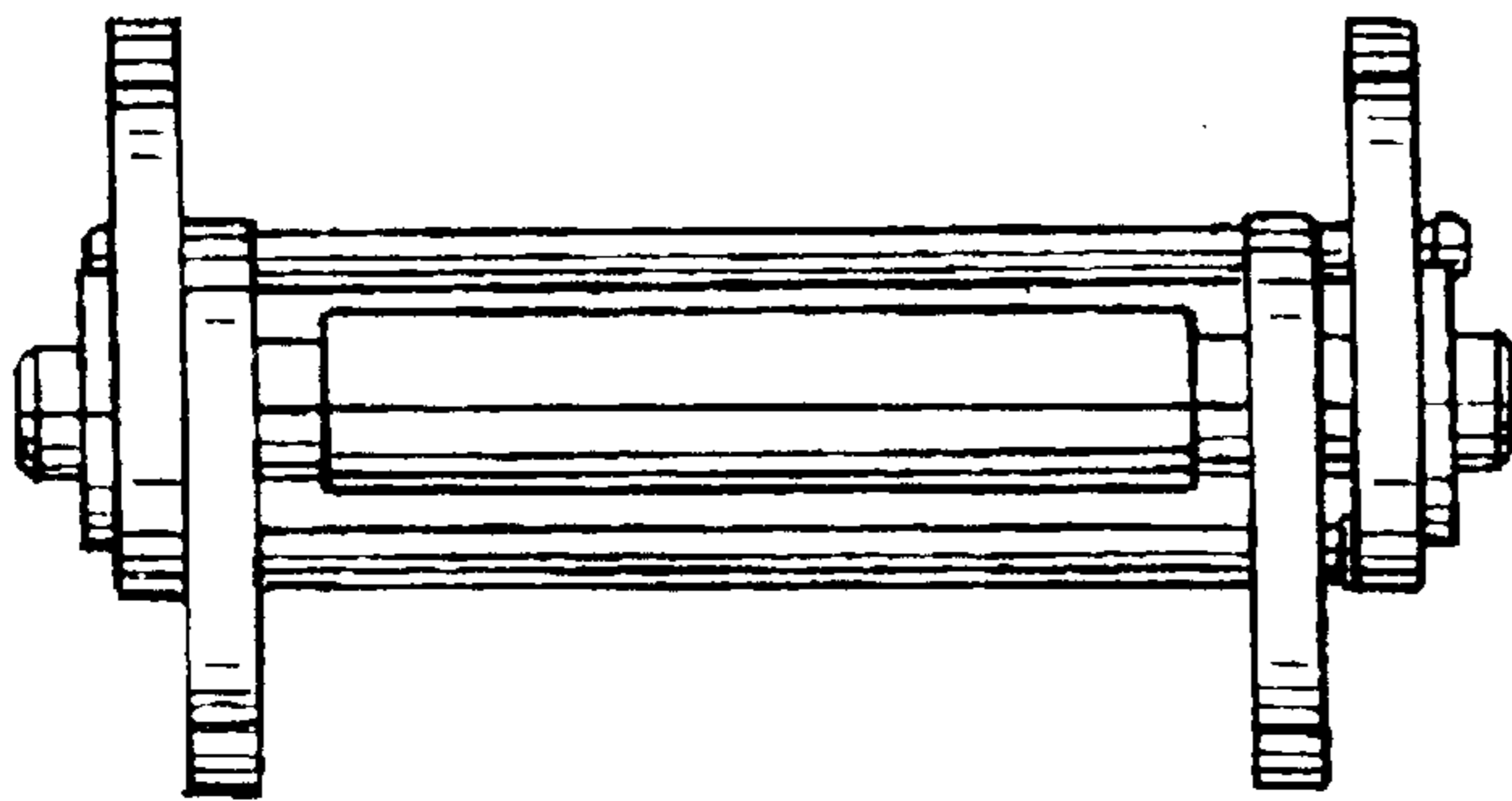
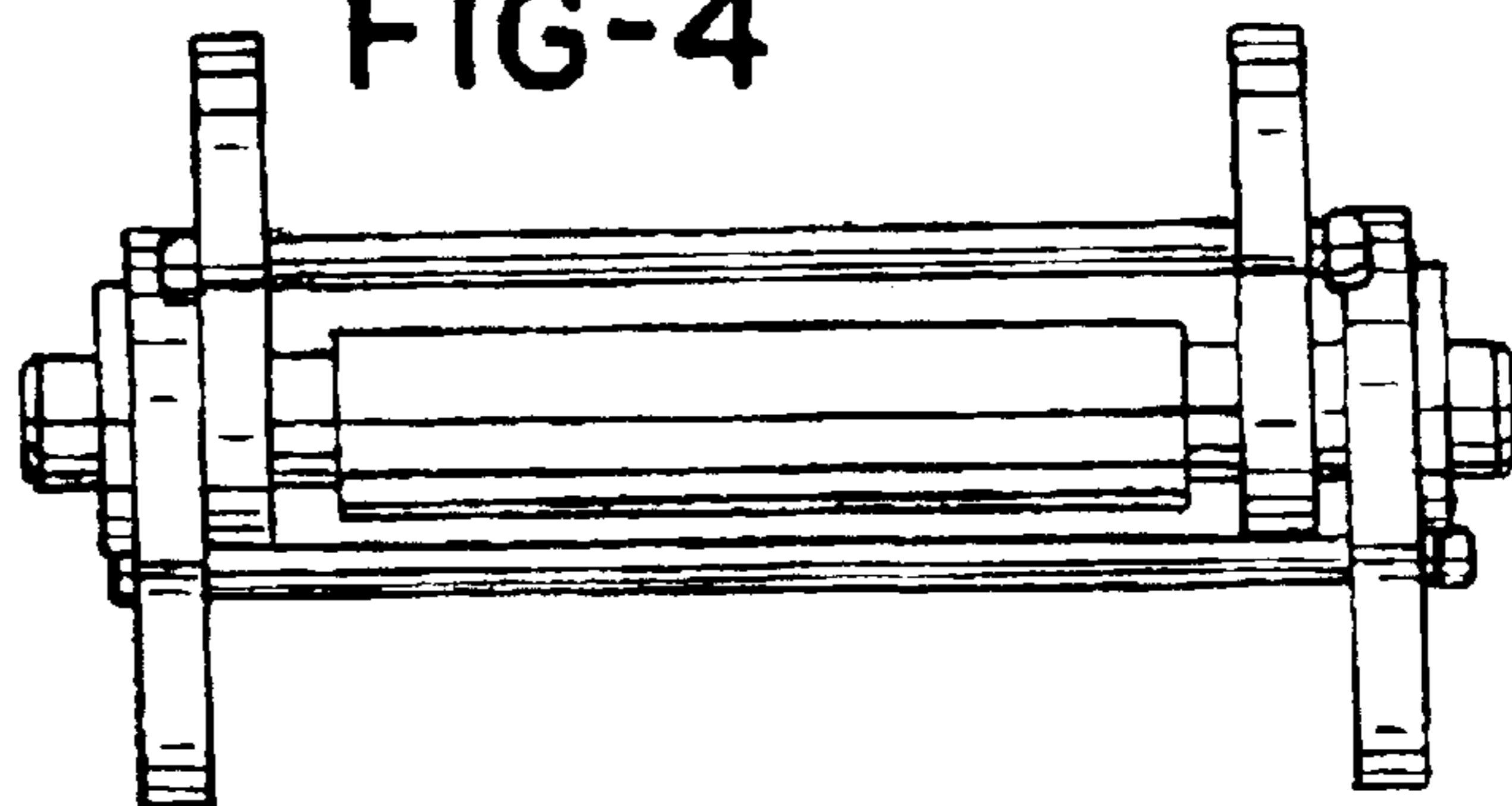
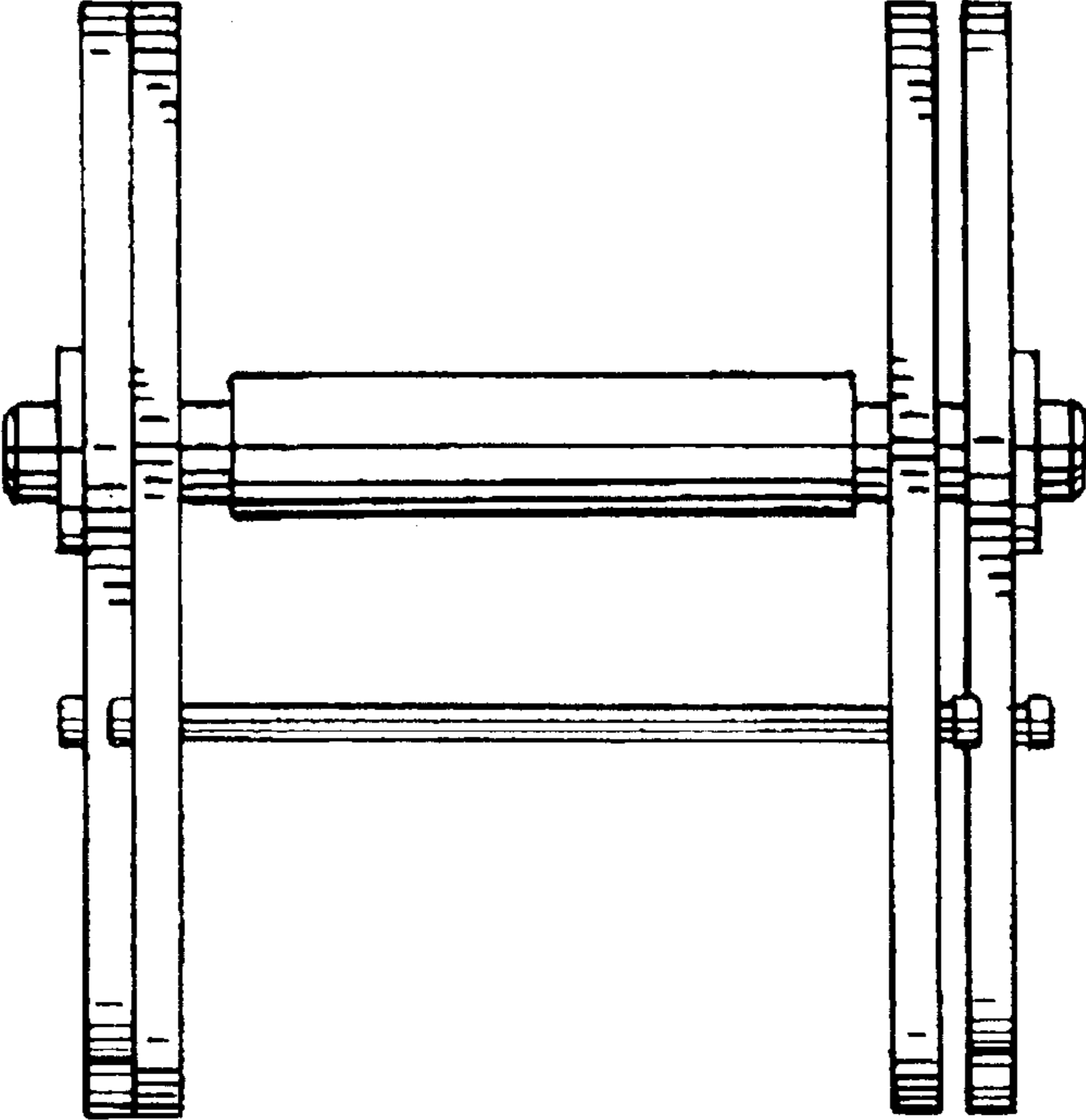

FIG-4



**FIG-5**



**FIG-6**

