



US00D510635S

(12) **United States Design Patent** (10) **Patent No.:** **US D510,635 S**
Rogers et al. (45) **Date of Patent:** **** Oct. 11, 2005**

(54) **VEHICLE LIGHT LENS**
(75) Inventors: **Thomas Walter Rogers**, Weston, WI (US); **Edgar Clarence Paffrath**, North Manchester, IN (US)
(73) Assignee: **Cequent Trailer Products, Inc.**, Mosinee, WI (US)
(**) Term: **14 Years**

(21) Appl. No.: **29/175,330**
(22) Filed: **Feb. 3, 2003**
(51) **LOC (8) Cl.** **26-06**
(52) **U.S. Cl.** **D26/28**
(58) **Field of Search** D26/28-36; 362/61, 362/80, 81, 82, 83, 83.4, 267, 269, 275, 330-340

(56) **References Cited**

U.S. PATENT DOCUMENTS

D417,298 S 11/1999 Paffrath et al.
D439,687 S * 3/2001 Iacovelli et al. D26/28
D439,994 S * 4/2001 Huang D26/28
D448,872 S * 10/2001 Clarke et al. D26/28
D500,153 S * 12/2004 Stephens et al. D26/28

OTHER PUBLICATIONS

Sierra Products, Inc., Aftermarket Lighting Products Catalog, Livermore, California, USA prior to Feb. 3, 2003.
Dry Launch, Boat Trailer Replacement and New User Lighting Catalog, Livermore, California, USA prior to Feb. 3, 2003.
Boaters World, Boaters World 2004 Catalog, Livermore, California, USA.

Wesbar, Trailer Products Catalog, Mosinee, Wisconsin, USA prior to Feb. 3, 2003.

* cited by examiner

Primary Examiner—Marcus A. Jackson
(74) *Attorney, Agent, or Firm*—Robert H. Earp, III; McDonald Hopkins Co., LPA

(57) **CLAIM**

The ornamental design for a vehicle light lens, as shown and described.

DESCRIPTION

FIG. 1 is a perspective view as seen from the top, front, and right side of a first embodiment of a vehicle light lens showing our new design;
FIG. 2 is a front elevational view thereof;
FIG. 3 is a rear elevational view thereof;
FIG. 4 is a bottom plan view thereof;
FIG. 5 is a top plan view thereof;
FIG. 6 is a left side elevational view thereof; and
FIG. 7 is a right side elevational view thereof.
FIG. 8 is a perspective view as seen from the top, front, and left side of a second embodiment of a vehicle light lens showing our new design;
FIG. 9 is a left side elevational view thereof; and
FIG. 10 is a right side elevational view thereof.

I should be appreciated that the second embodiment of the vehicle light lens is identical to the first embodiment but as a mirror image thereof. Particularly, the second embodiment includes right and left sides that are reversed from the right and left sides in the first embodiment. Therefore, the second embodiment of the vehicle light lens is fully shown as the mirror image of each of the Figures of the first embodiment. For the sake of simplicity, only the perspective, right and left side views of the second embodiment are shown. The broken lines in FIGS. 2, 3, 4, 6, 7, 9 and 10 showing the lens opening lip are used for illustrative purposes only and forms no part of the claimed design.

1 Claim, 4 Drawing Sheets

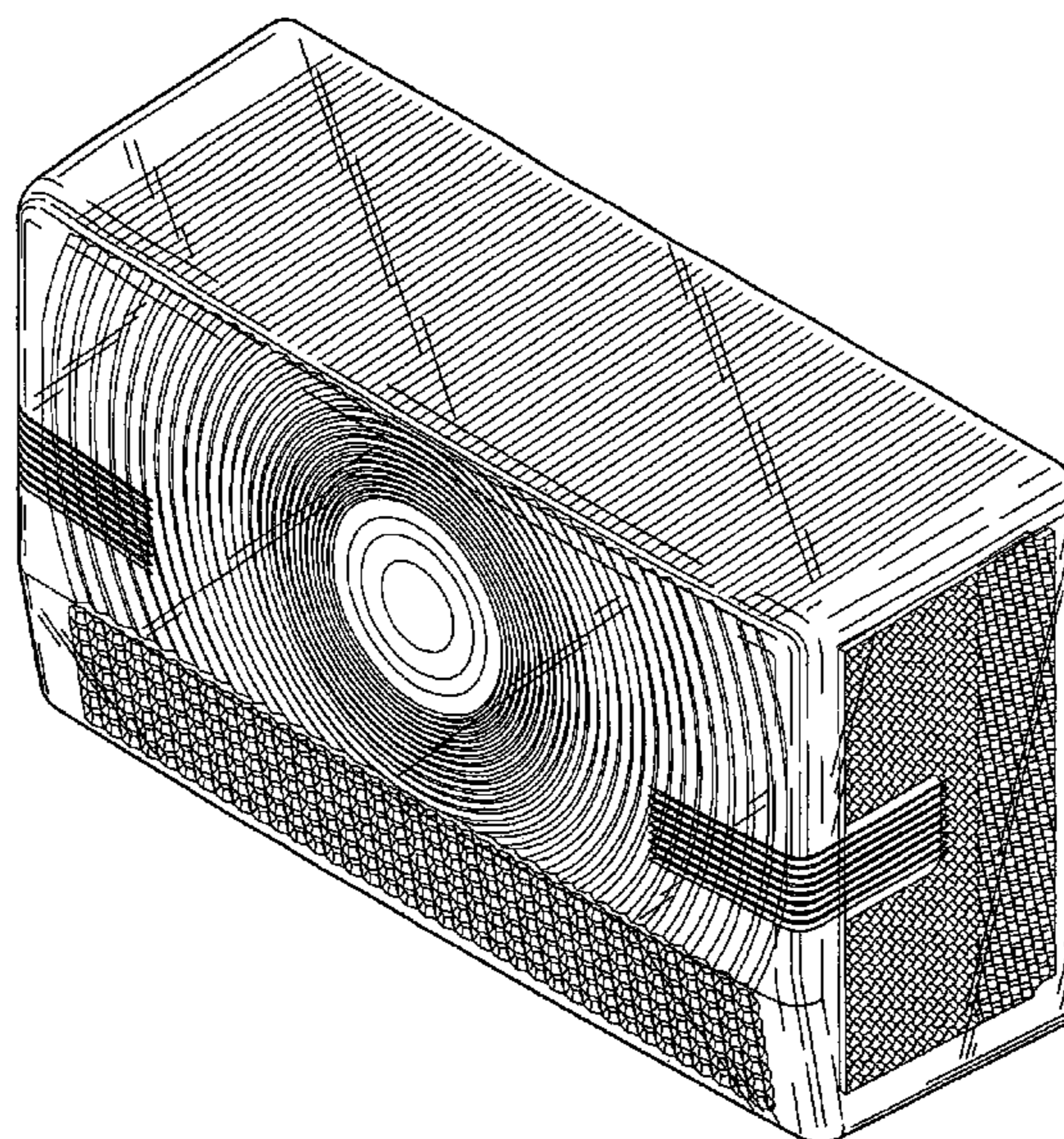

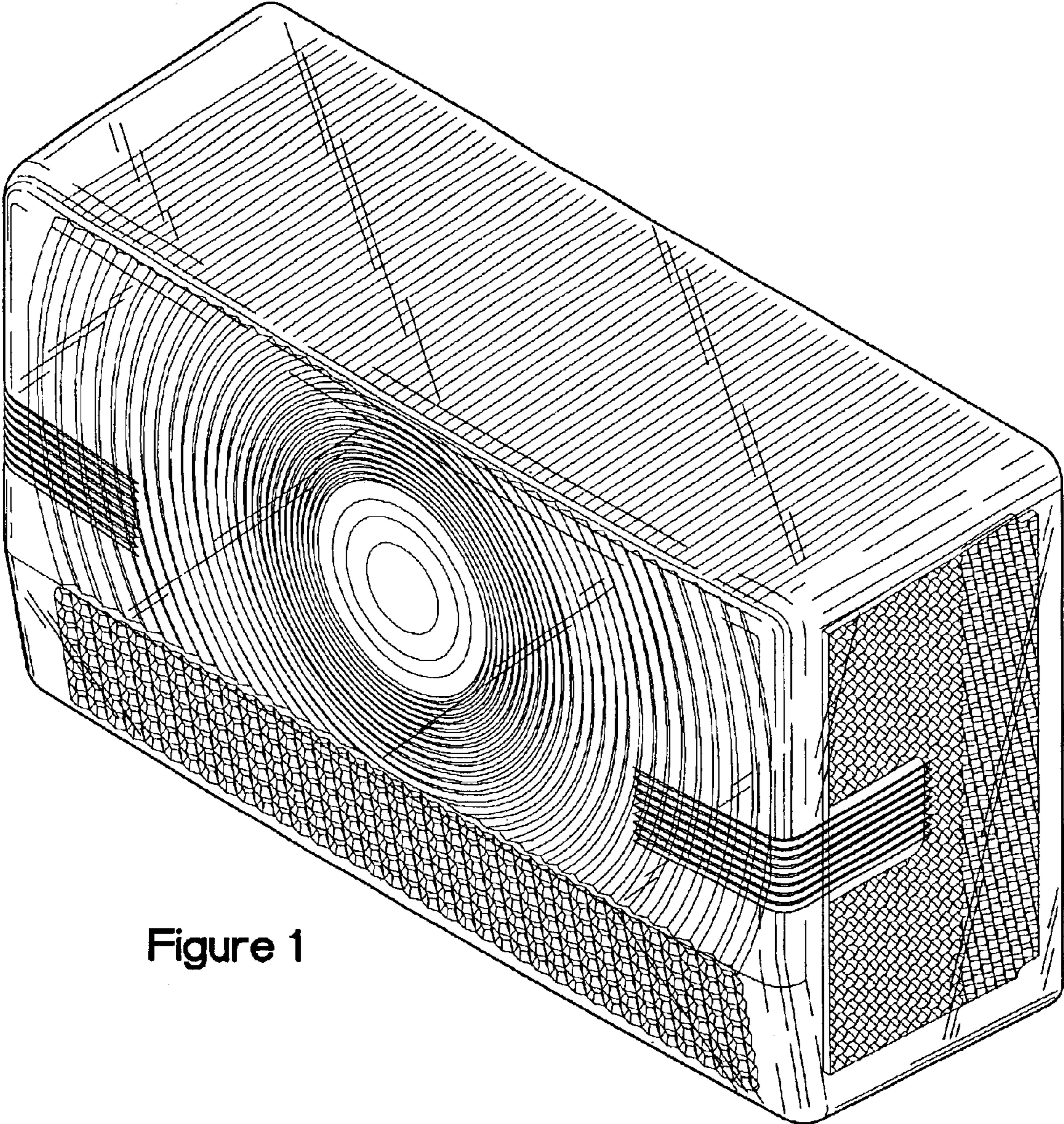

Figure 1

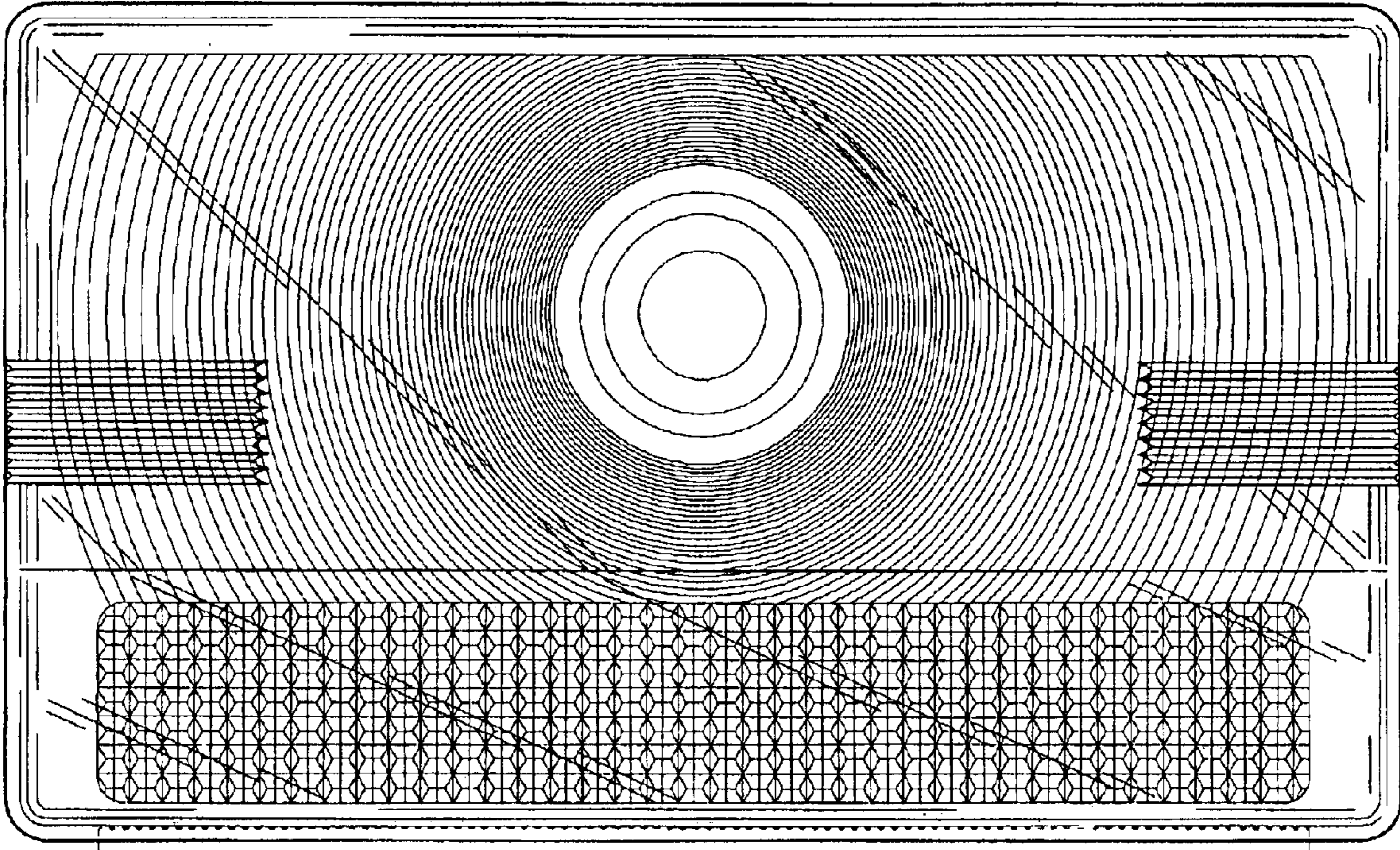

Figure 2

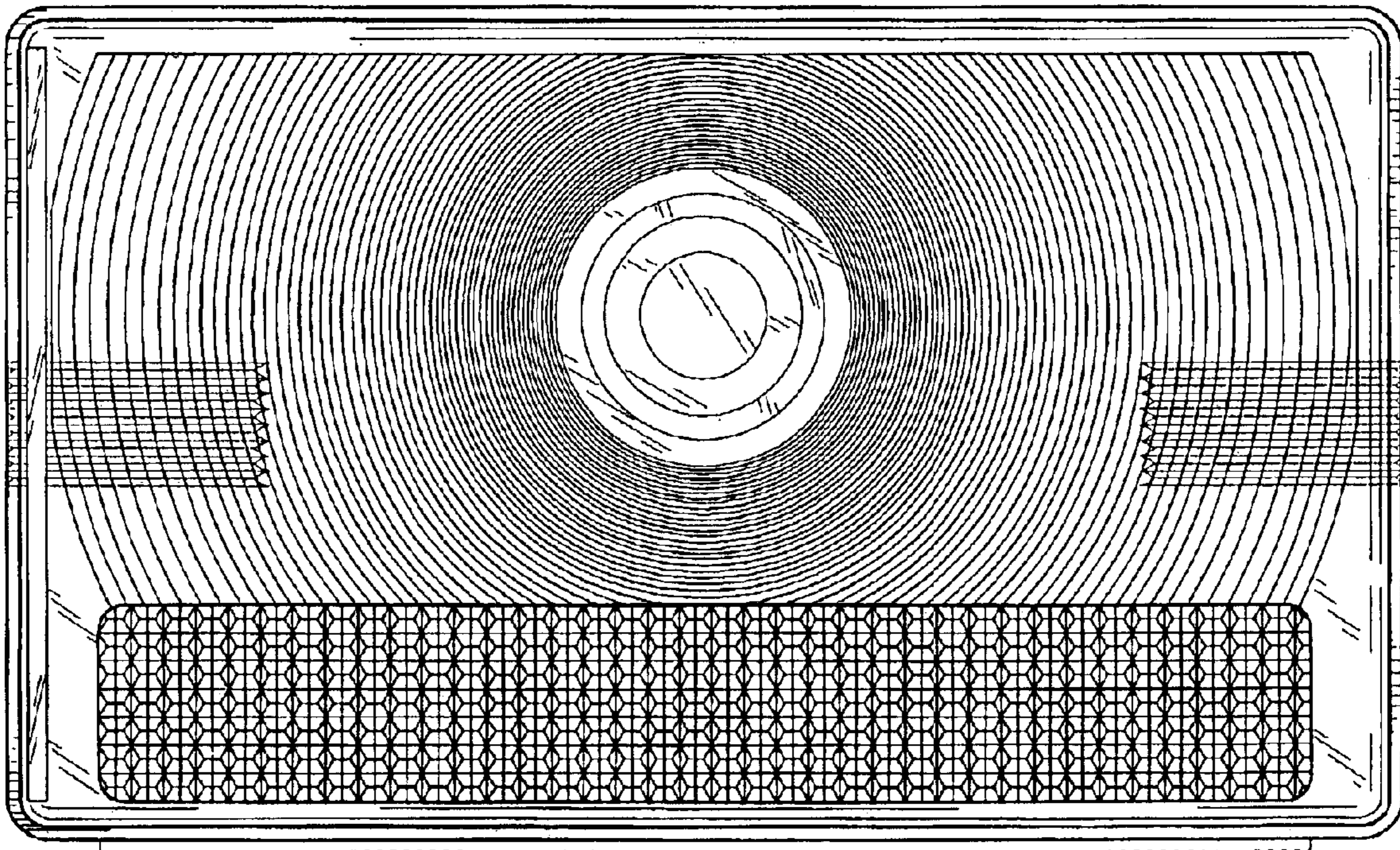

Figure 3

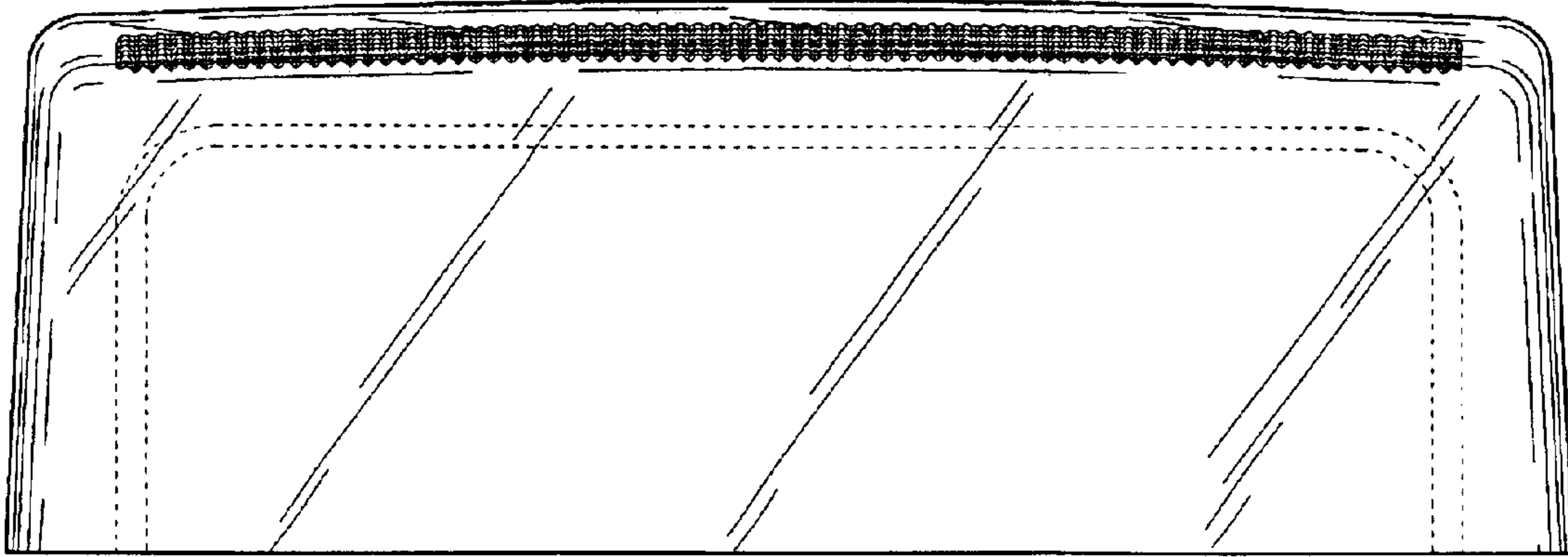

Figure 4

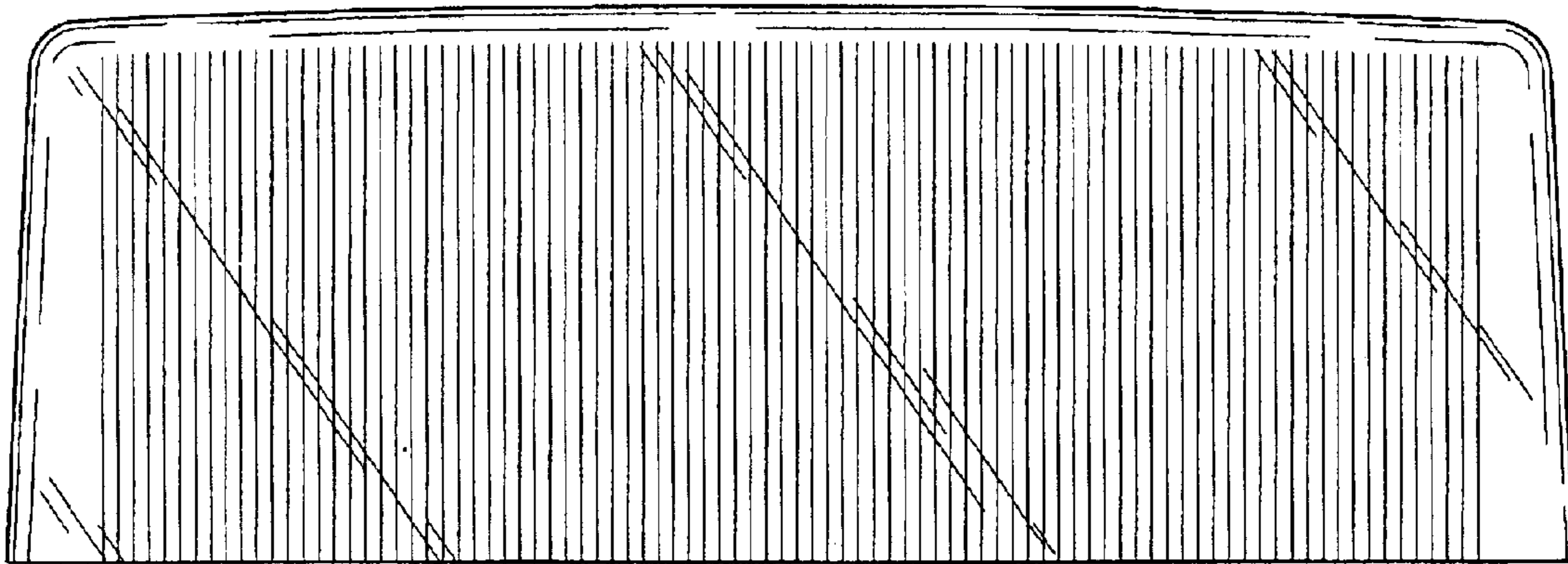

Figure 5

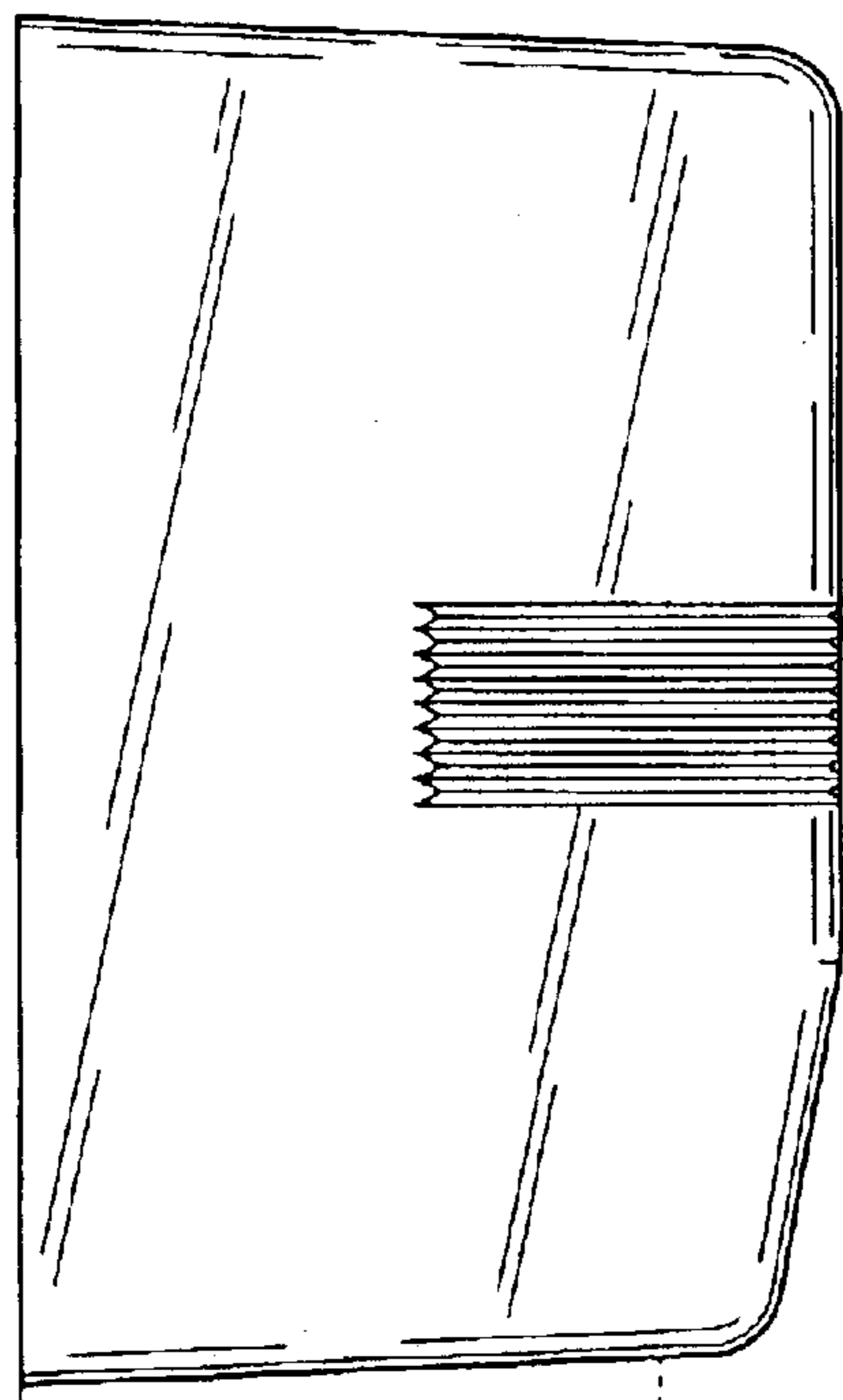

Figure 6

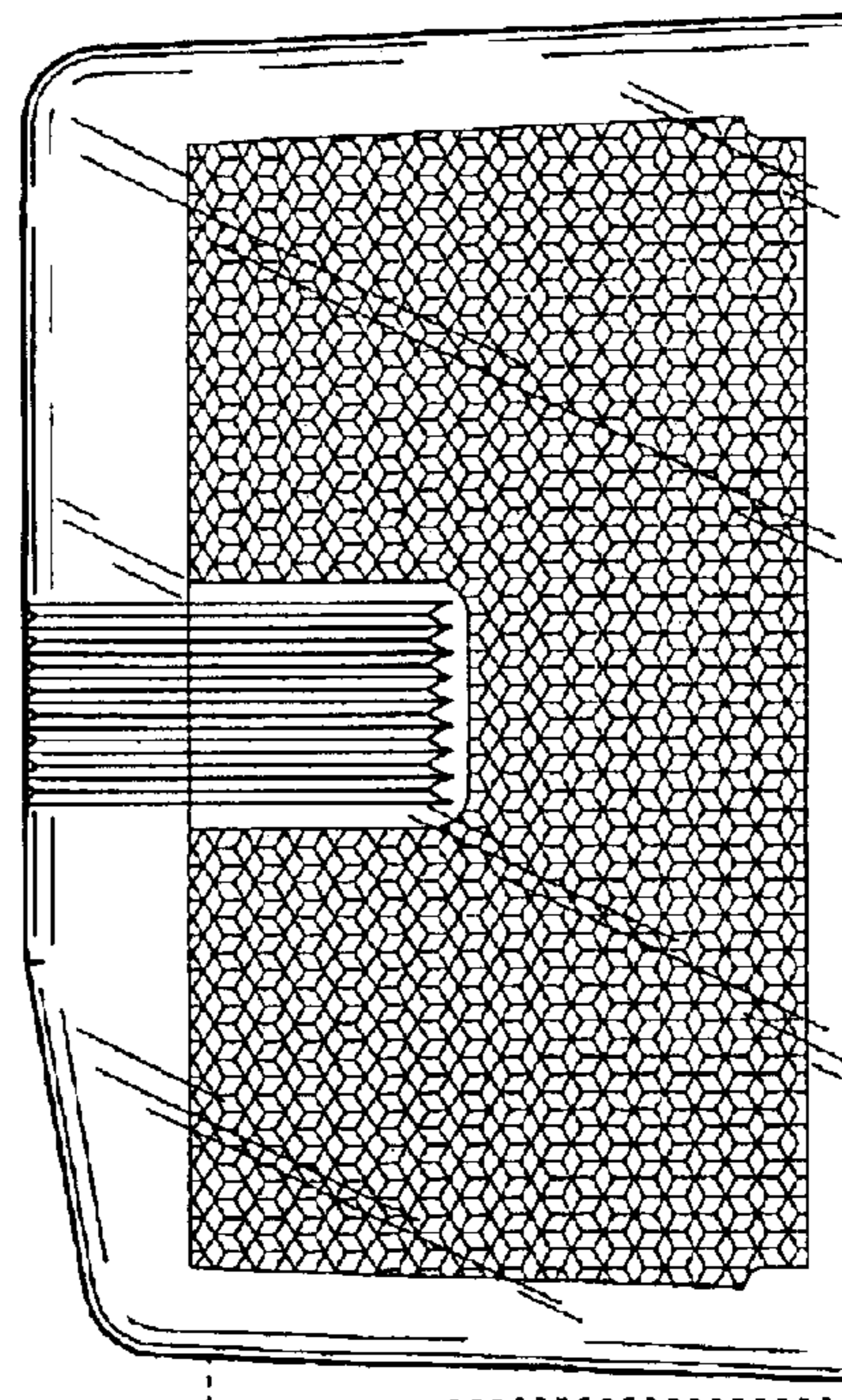

Figure 7

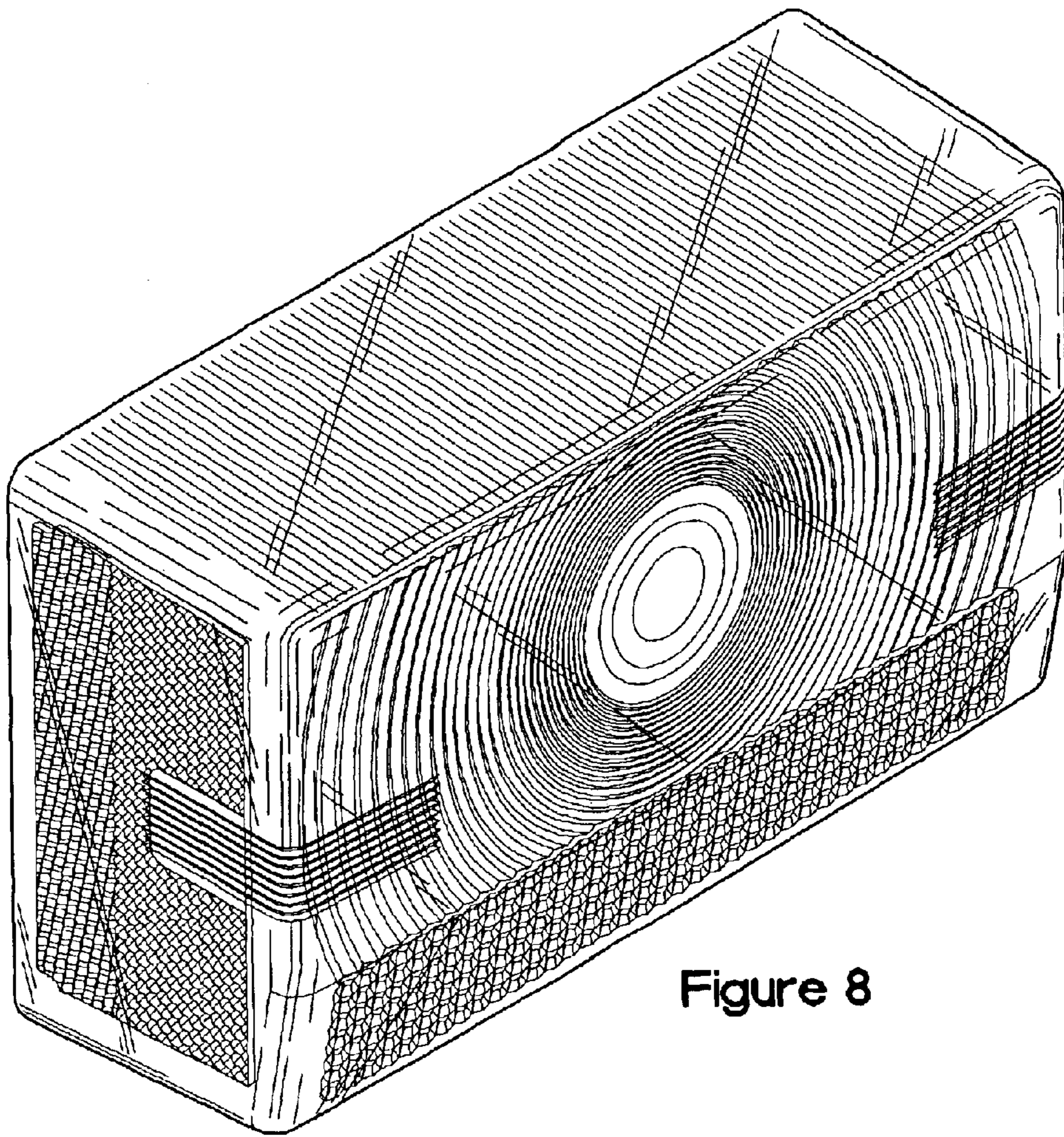

Figure 8

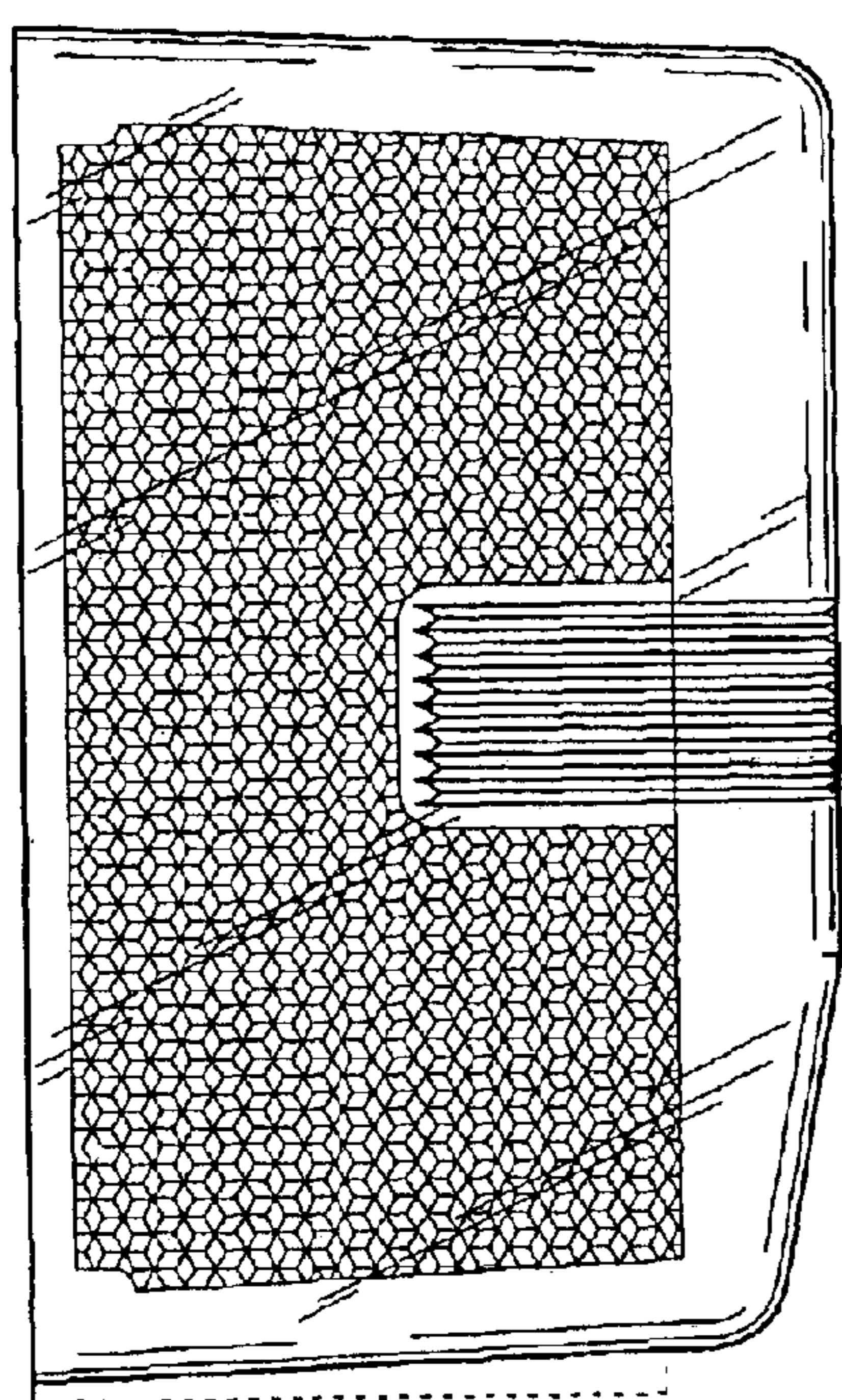

Figure 9

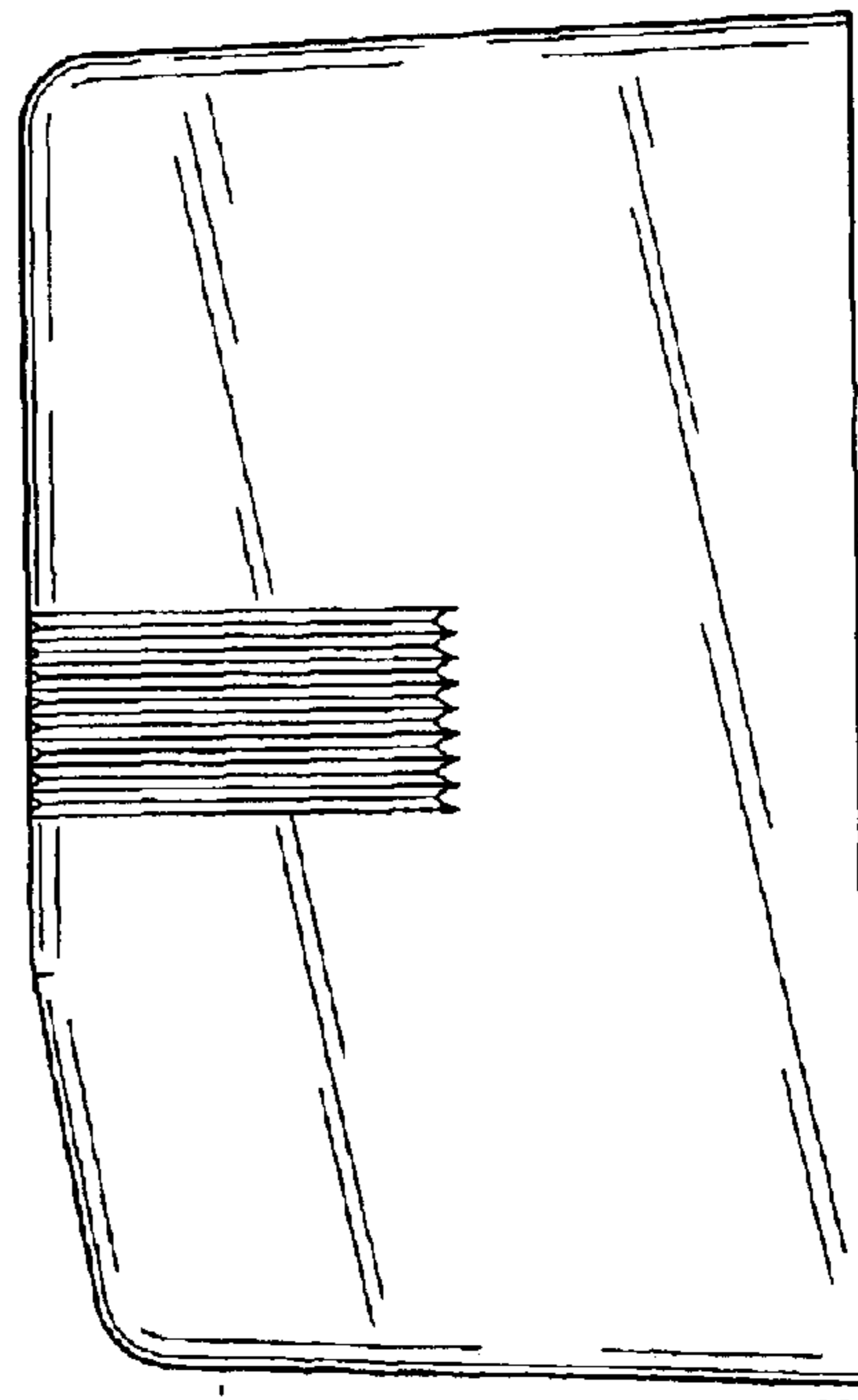

Figure 10