



US00D510546S

(12) **United States Design Patent** (10) **Patent No.:** **US D510,546 S**
Doll (45) **Date of Patent:** **** Oct. 11, 2005**

(54) **MOTORCYCLE FRAME**
(75) Inventor: **Vincent K. Doll**, Liberty, SC (US)
(73) Assignee: **Rednex, Inc.**, Liberty, SC (US)
(**) Term: **14 Years**
(21) Appl. No.: **29/209,246**
(22) Filed: **Jul. 13, 2004**
(51) **LOC (8) Cl.** **12-11**
(52) **U.S. Cl.** **D12/110**
(58) **Field of Search** **D12/110, 117;**
180/219, 311, 312; 280/274, 278, 281.1,
287, 288.1-288.3

Web pages showing motorcycle frames from <www.daytec-center.com/>.
Web pages showing motorcycle frames from <www.big-bearchoppers.com/>.
Web pages showing motorcycle frames from <www.rollingthunderframes.com/>.
Web pages showing motorcycle frames from <www.shop-pcc.com/>.
J. Deasey, "Chunky Thunder: Mean, but Definitely Not Lean," from <www.hotrodbikes.com/features/0307hrb_exilecycles/>.

Primary Examiner—Alan P. Douglas
Assistant Examiner—Linda Brooks
(74) *Attorney, Agent, or Firm*—Nelson Mullins Riley & Scarborough

(56) **References Cited**
U.S. PATENT DOCUMENTS
6,142,498 A 11/2000 Smith
D494,106 S 8/2004 Doll

(57) **CLAIM**
The ornamental design for a motorcycle frame, substantially as shown and described.

OTHER PUBLICATIONS
H. Kelly, "Vision Quest: An Original Idea," *Street Chopper* (Jun. 2003).
G. Friend, "Long and Lean: Keepin' It Clean," *Street Chopper* (Jun. 2003).
S. Bohn, "South Dakota Springer: A Car Builder Tries his Hand at a Chopper," *Street Chopper* (Jun. 2003).
Web pages showing motorcycle frames from <www.foghol-low.com/>.
Web pages showing motorcycle frames from <www.red-neckengineering.com/>.
Web pages showing motorcycle frames from <www.redneckengineering.com/>.
Web page showing motorcycle frames from <www.xtremecyclesdesign.com/>.
Web pages showing motorcycle frames from <www.war-eaglecustoms.com/>.
Web pages showing motorcycle frames from <www.chicagochopperworks.com/>.

DESCRIPTION
FIG. 1 is a perspective view of a motorcycle frame embodying the design of the present invention.
FIG. 2 is a right side elevational view of the motorcycle frame illustrated in FIG. 1.
FIG. 3 is a left side elevational view of the motorcycle frame illustrated in FIG. 1.
FIG. 4 is a front elevational view of the motorcycle frame illustrated in FIG. 1.
FIG. 5 is a back elevational view of the motorcycle frame illustrated in FIG. 1.
FIG. 6 is a top view of the motorcycle frame illustrated in FIG. 1; and,
FIG. 7 is a bottom view of the motorcycle frame illustrated in FIG. 1.
The portions shown in broken lines form no part of the claimed design.

1 Claim, 3 Drawing Sheets

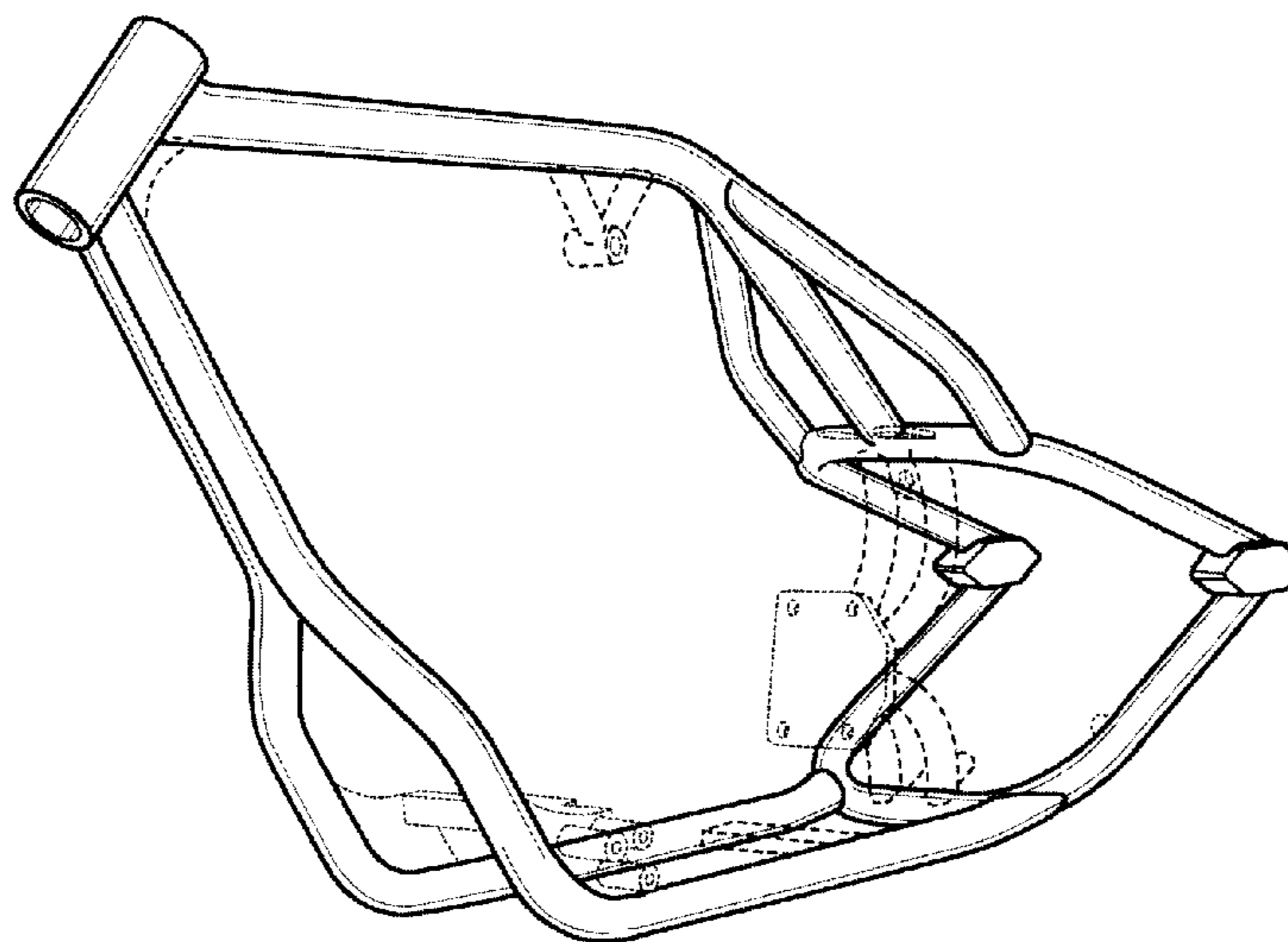

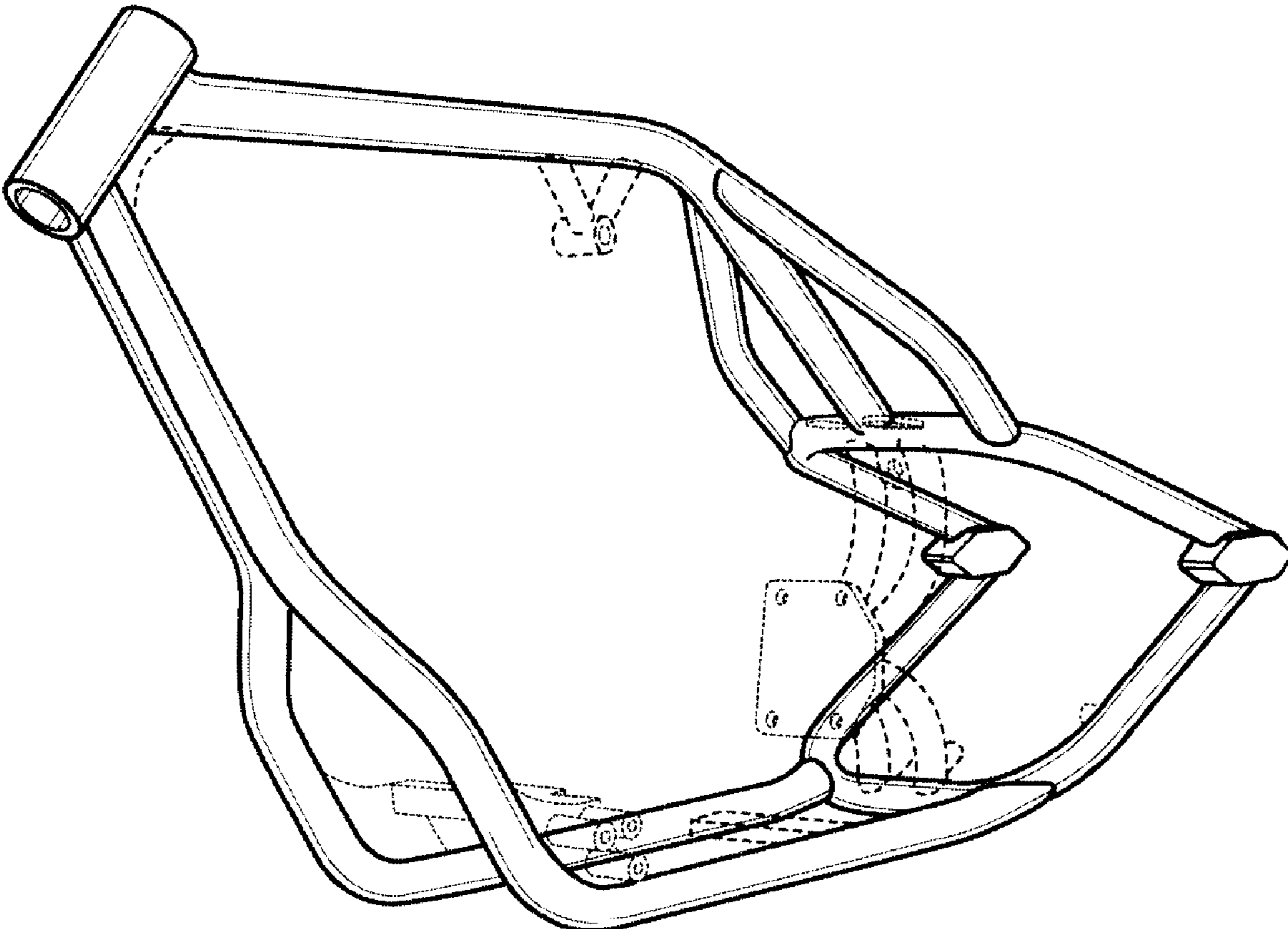

FIG. 1

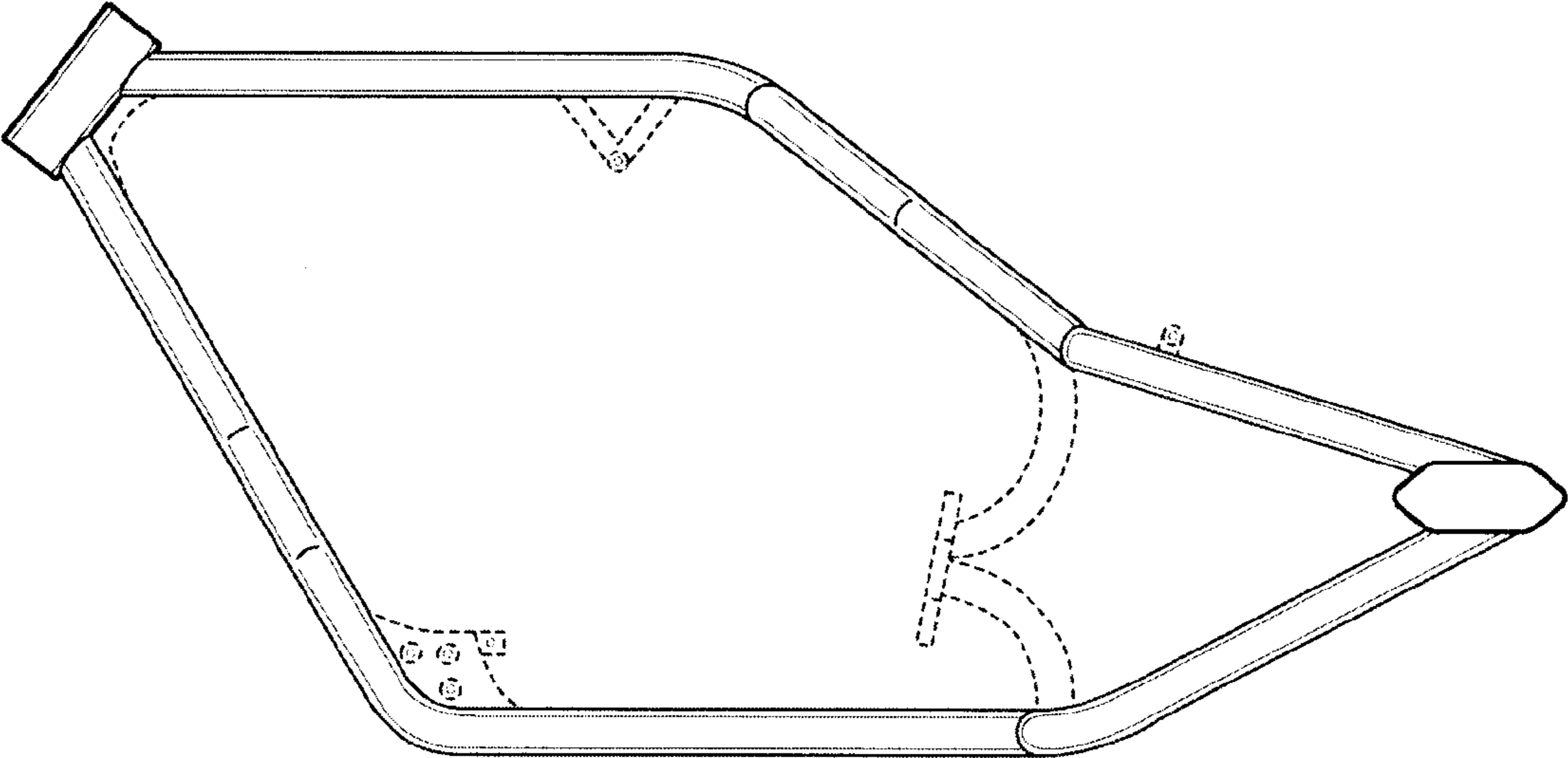

FIG. 2

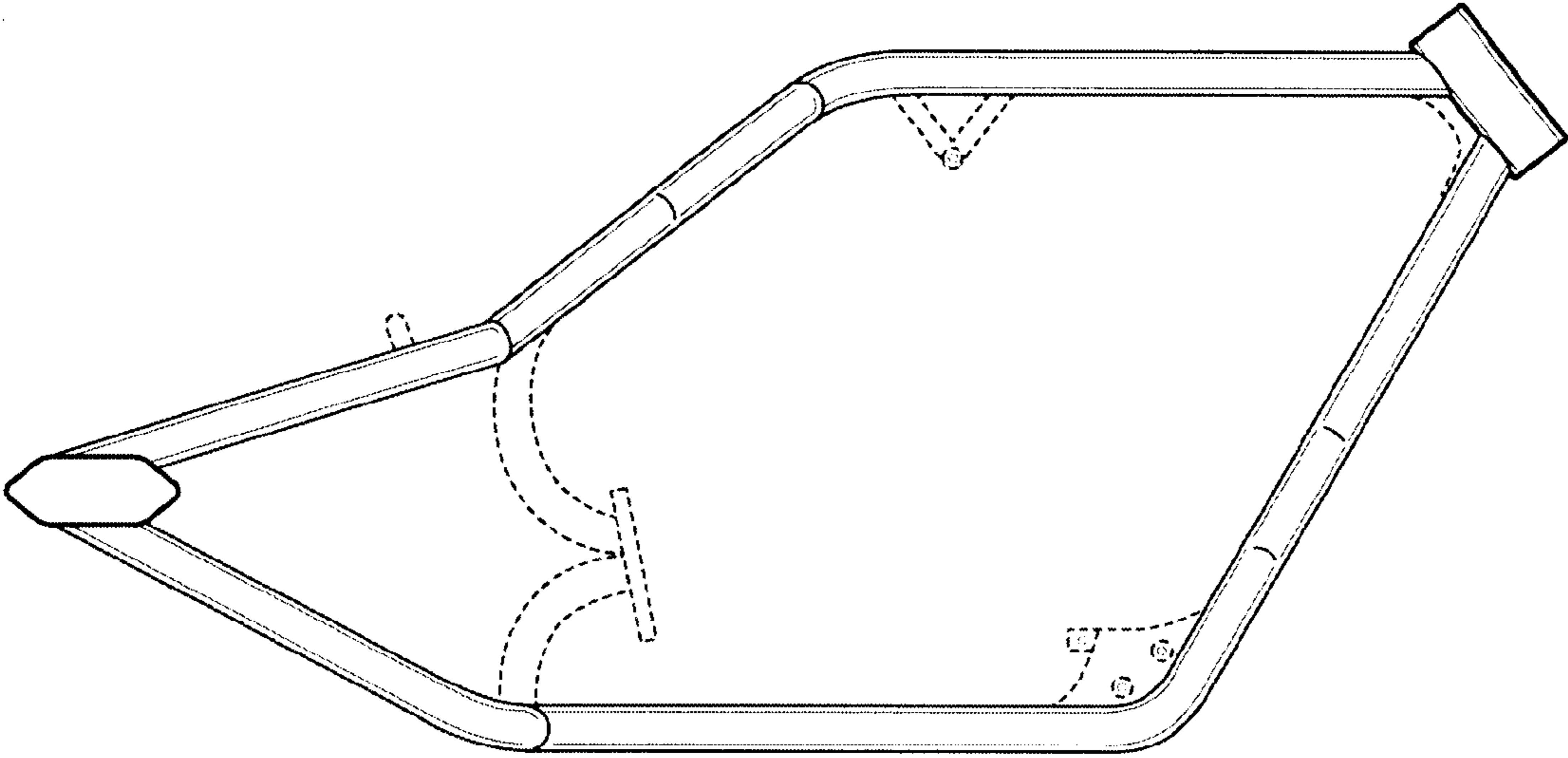

FIG. 3

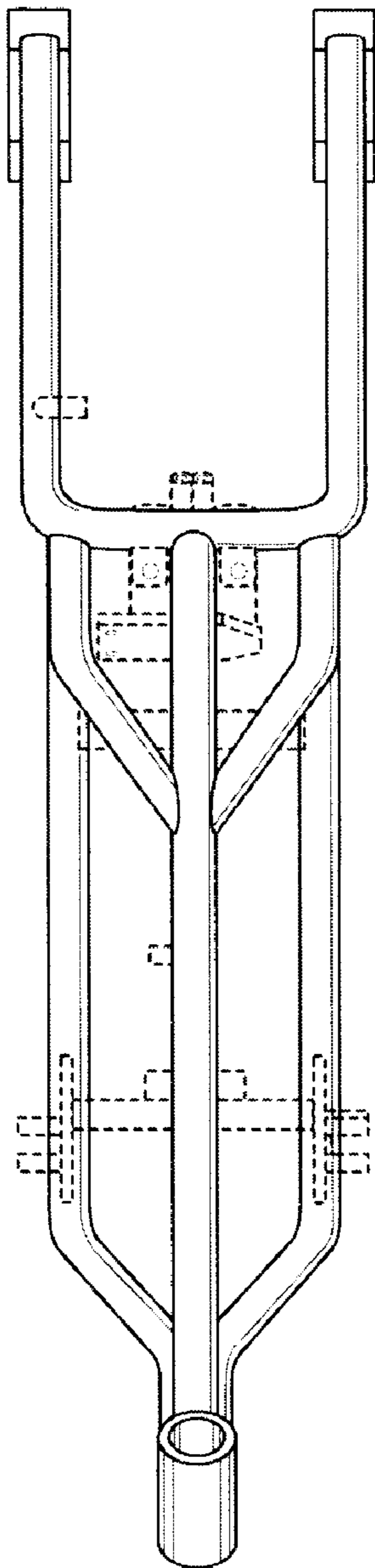

FIG. 6

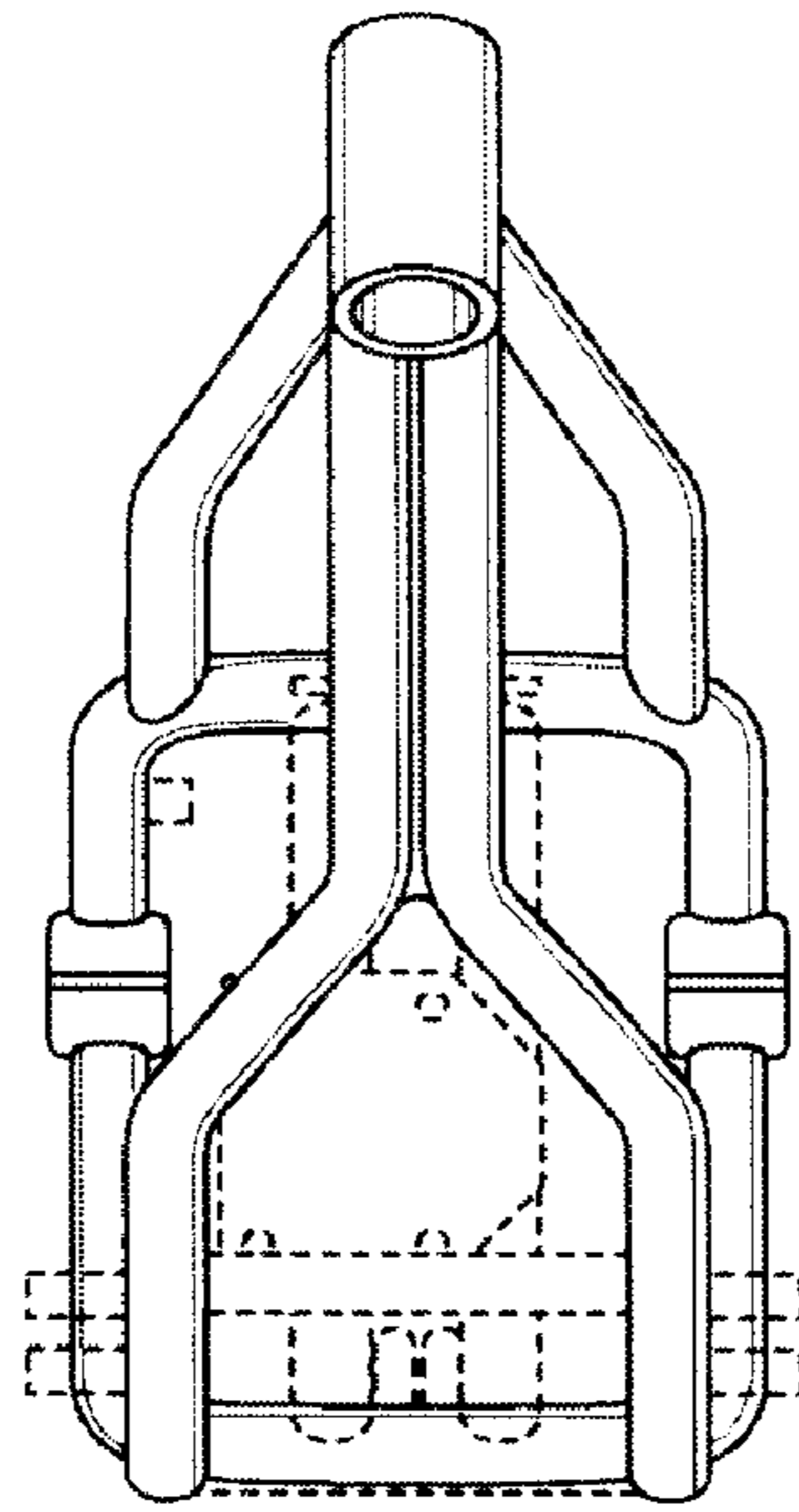

FIG. 4

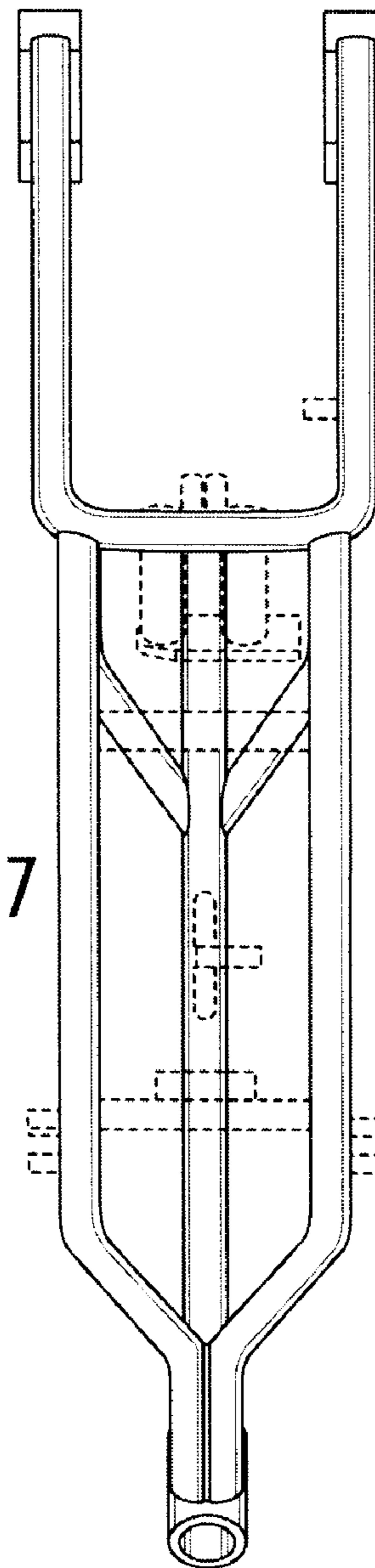

FIG. 7

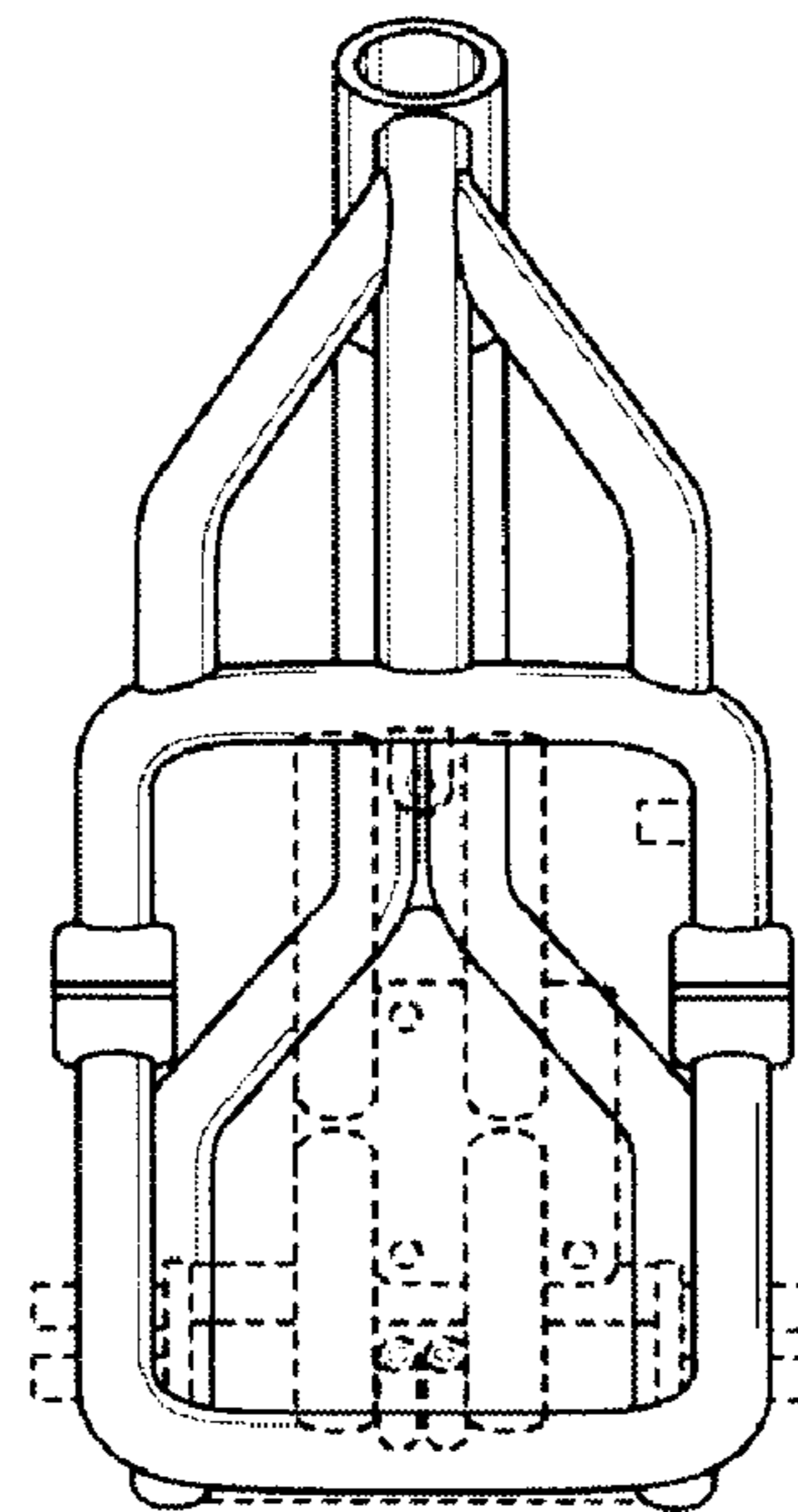

FIG. 5