



US00D510148S

(12) **United States Design Patent**
Huang

(10) **Patent No.:** **US D510,148 S**
(45) **Date of Patent:** **** Sep. 27, 2005**

(54) **RIGHT-ANGLE LED MARKER LIGHTS FOR VEHICLE**

(75) Inventor: **Nan Huang Huang**, Rancho Palos Verdes, CA (US)

(73) Assignee: **Grand General Accessories Manufacturing Inc.**, Compton, CA (US)

(**) Term: **14 Years**

(21) Appl. No.: **29/217,479**

(22) Filed: **Nov. 17, 2004**

(51) **LOC (8) Cl.** **26-06**

(52) **U.S. Cl.** **D26/28; D26/2**

(58) **Field of Search** **D26/28-36; 362/61, 362/80, 81, 82, 83, 83.4, 267, 269, 275, 330-340**

(56) **References Cited**

U.S. PATENT DOCUMENTS

| | | | | | |
|------------|---|---------|---------------|-------|--------|
| D402,772 S | * | 12/1998 | Lodhie | | D26/2 |
| D458,696 S | * | 6/2002 | Katogi et al. | | D26/2 |
| D474,848 S | * | 5/2003 | Lodhie | | D26/2 |
| D492,804 S | * | 7/2004 | Horowitz | | D26/28 |

* cited by examiner

Primary Examiner—Marcus A. Jackson

(74) *Attorney, Agent, or Firm*—Thomas I. Rozsa; Tony D. Chen

(57) **CLAIM**

The ornamental design for right-angle LED marker lights for vehicle, as shown and described.

DESCRIPTION

FIG. 1 is a perspective view of my invention of a new design of right-angle LED marker lights for vehicle, showing a preferred embodiment of the new design with four (4) light emitting diodes (LEDs);

FIG. 2 is a top view of the embodiment shown in FIG. 1; FIG. 3 is a bottom view of the embodiment shown in FIG. 1;

FIG. 4 is a front end elevation view of the embodiment shown in FIG. 1;

FIG. 5 is a rear end elevation view of the embodiment shown in FIG. 1;

FIG. 6 is a right side elevation view of the embodiment shown in FIG. 1;

FIG. 7 is a left side elevation view of the embodiment shown in FIG. 1;

FIG. 8 is a perspective view of my invention of a new design of right-angle LED marker lights for vehicle, showing a preferred alternative embodiment of the new design with six (6) LEDs;

FIG. 9 is a top view of the embodiment shown in FIG. 8; FIG. 10 is a bottom view of the embodiment shown in FIG. 8;

FIG. 11 is a front end elevation view of the embodiment shown in FIG. 8;

FIG. 12 is a rear end elevation view of the embodiment shown in FIG. 8;

FIG. 13 is a right side elevation view of the embodiment shown in FIG. 8;

FIG. 14 is a left side elevation view of the embodiment shown in FIG. 8;

FIG. 15 is a perspective view of my invention of a new design of right-angle LED marker lights for vehicle, showing another preferred alternative embodiment of the new design with eight (8) LEDs;

FIG. 16 is a top view of the embodiment shown in FIG. 15; FIG. 17 is a bottom view of the embodiment shown in FIG. 15;

FIG. 18 is a front end elevation view of the embodiment shown in FIG. 15;

FIG. 19 is a rear end elevation view of the embodiment shown in FIG. 15;

FIG. 20 is a right side elevation view of the embodiment shown in FIG. 15; and,

FIG. 21 is a left side elevation view of the embodiment shown in FIG. 15.

1 Claim, 3 Drawing Sheets

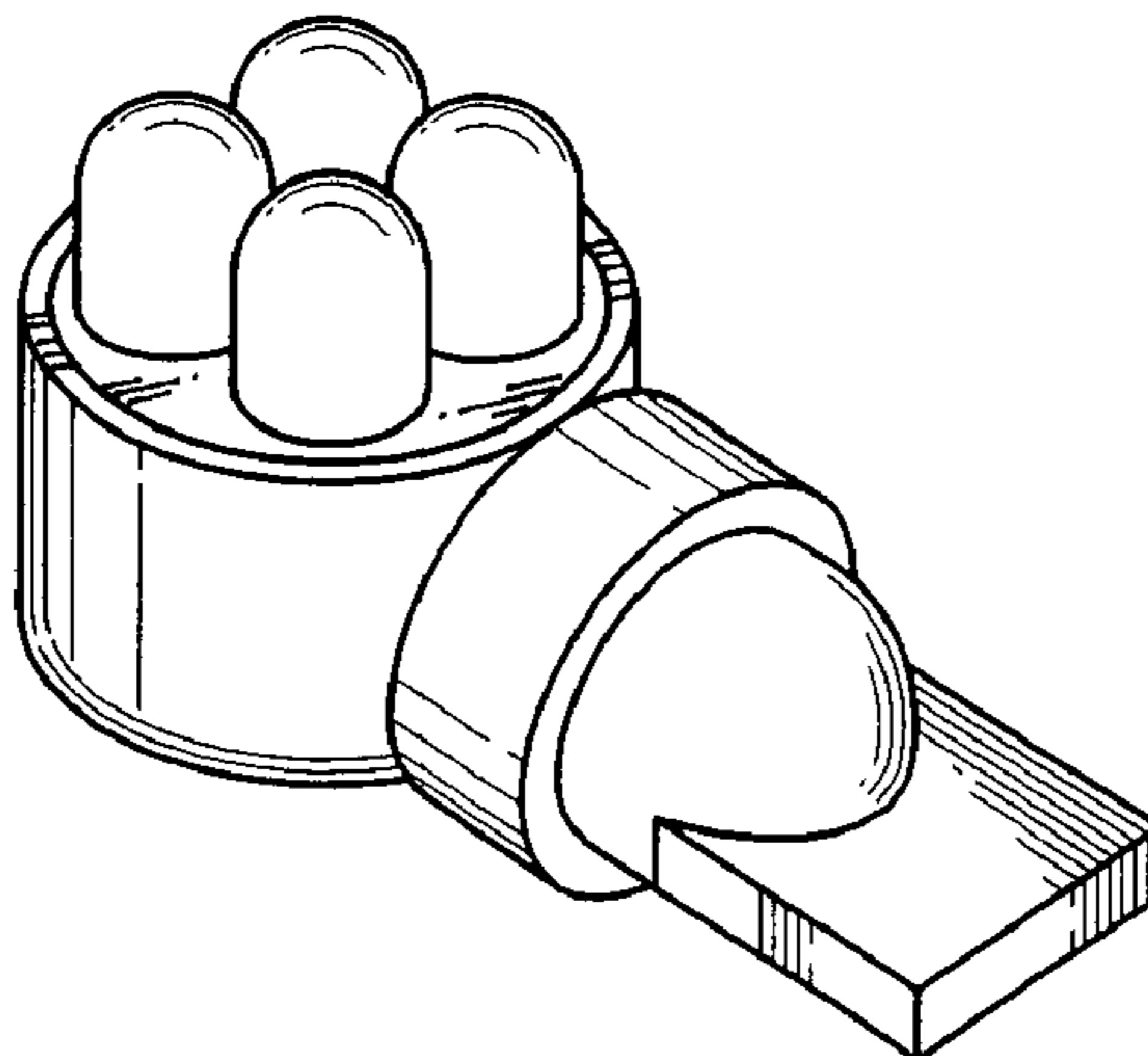

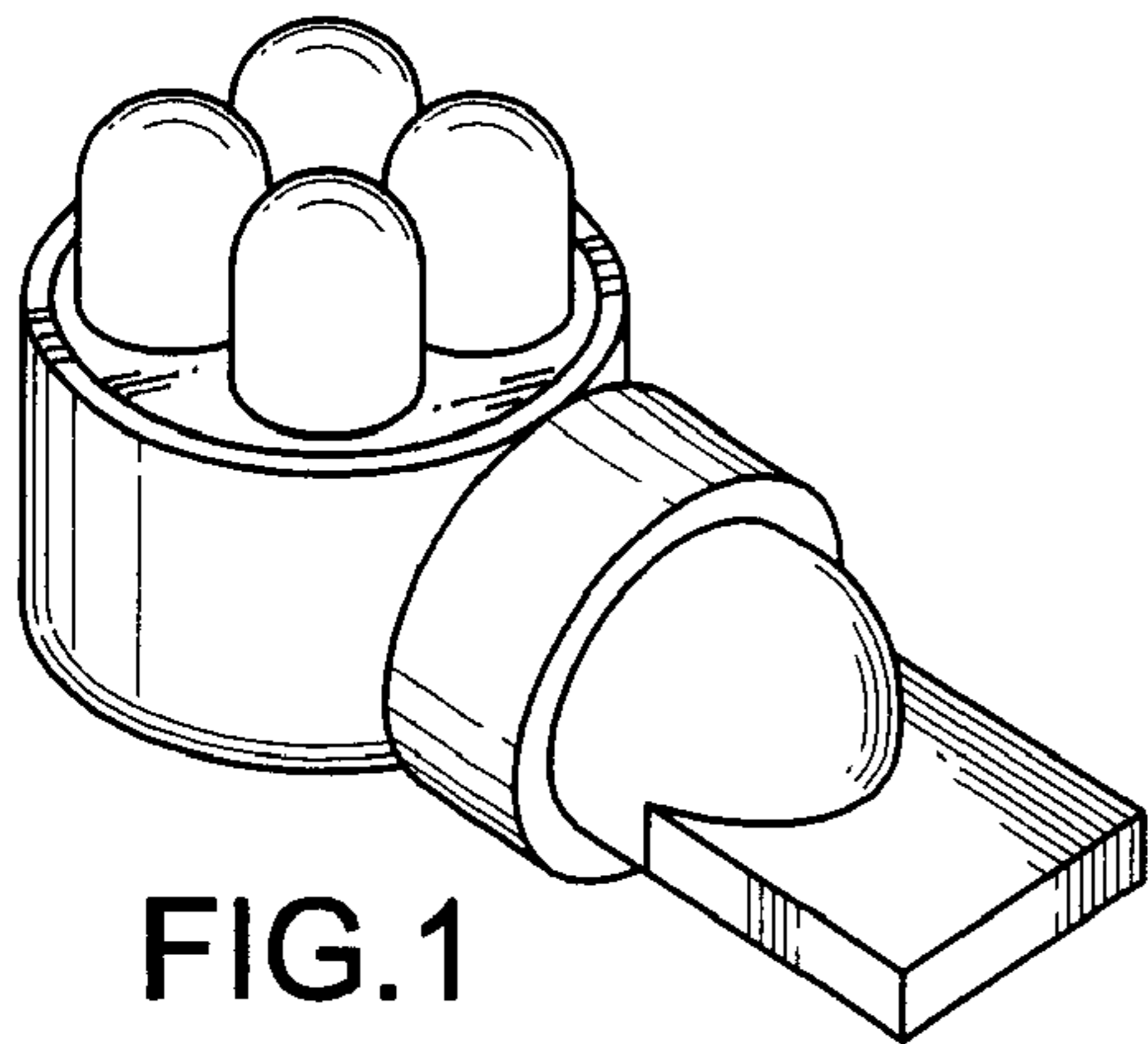

FIG. 1

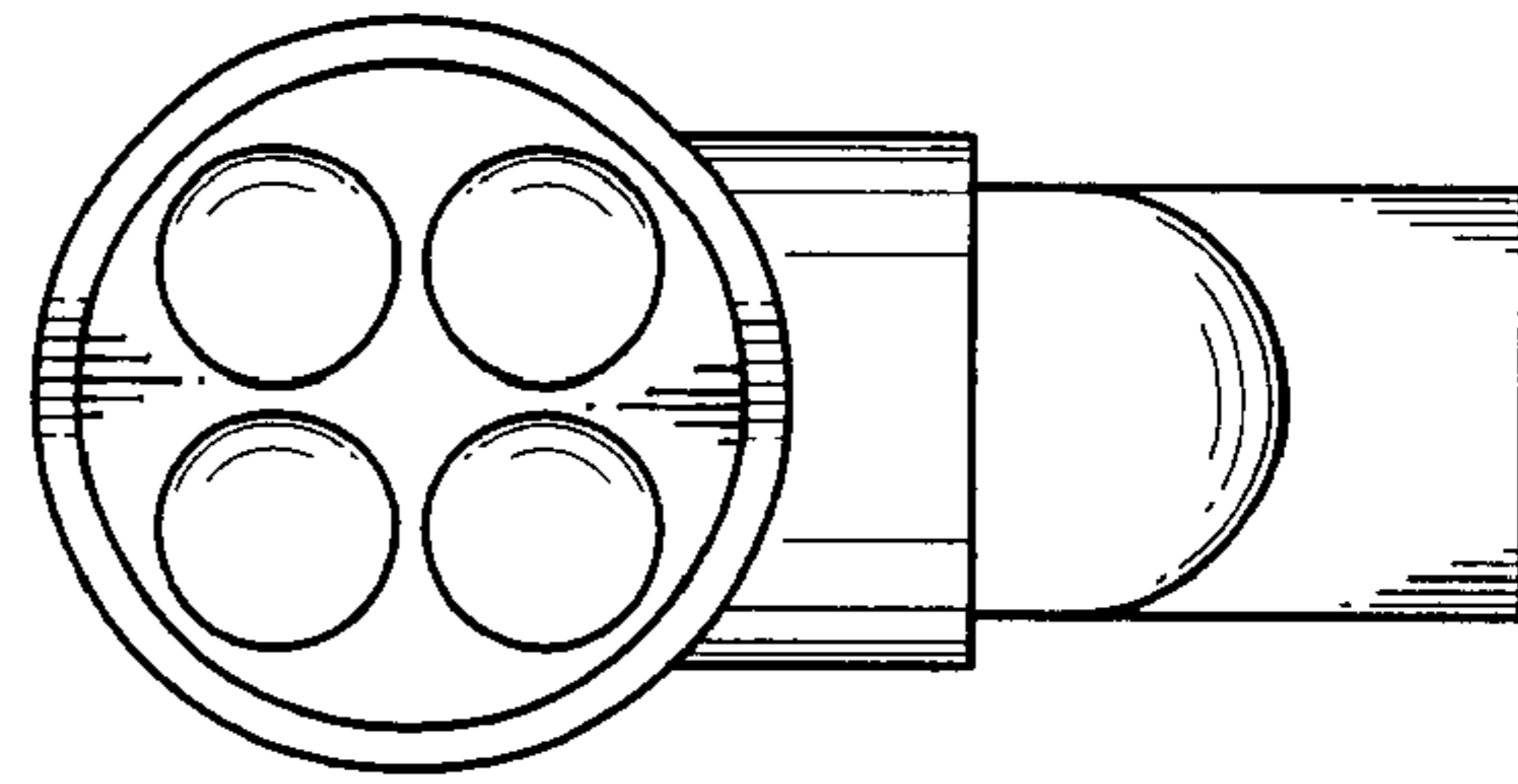

FIG. 2

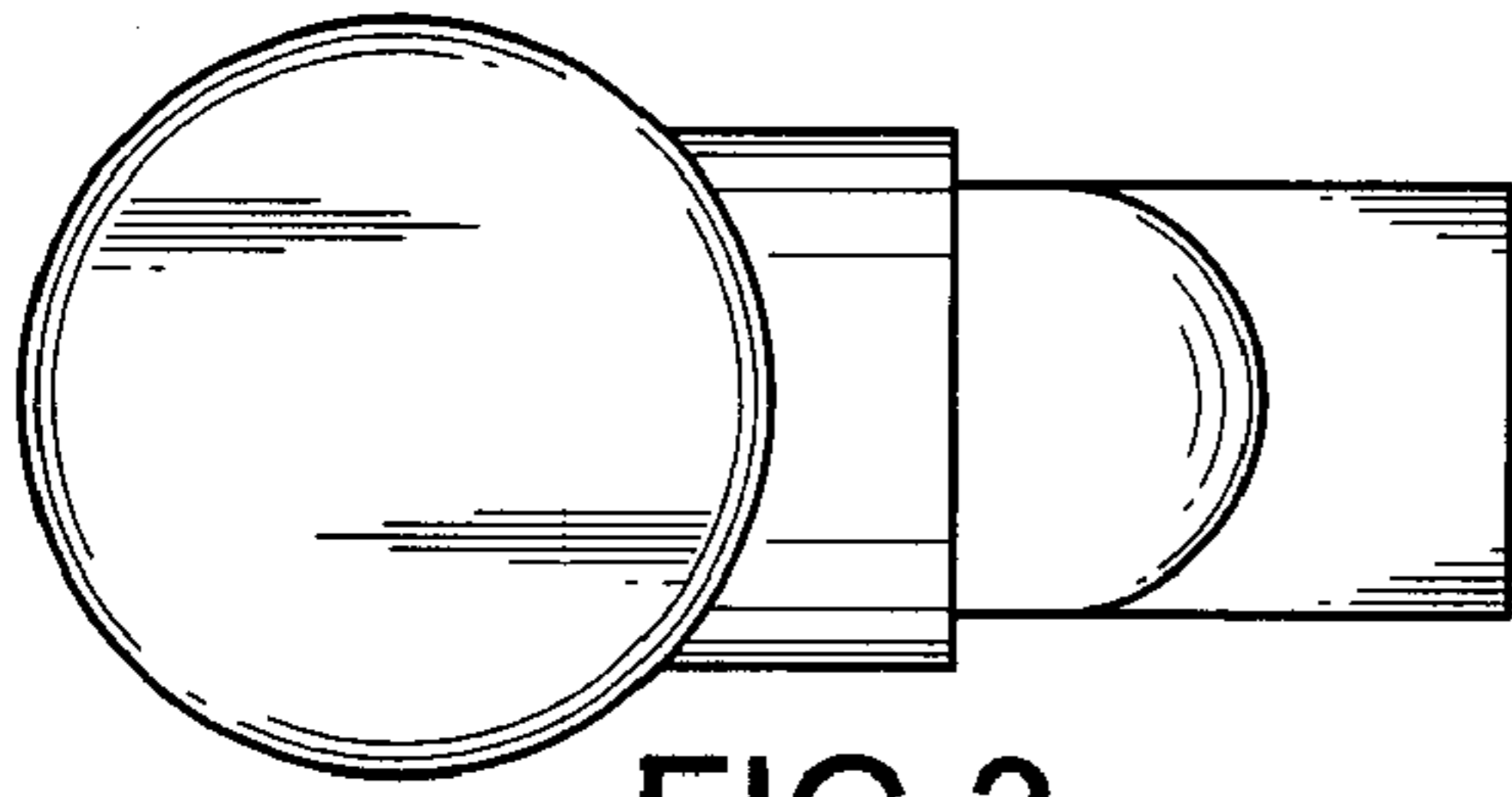

FIG. 3

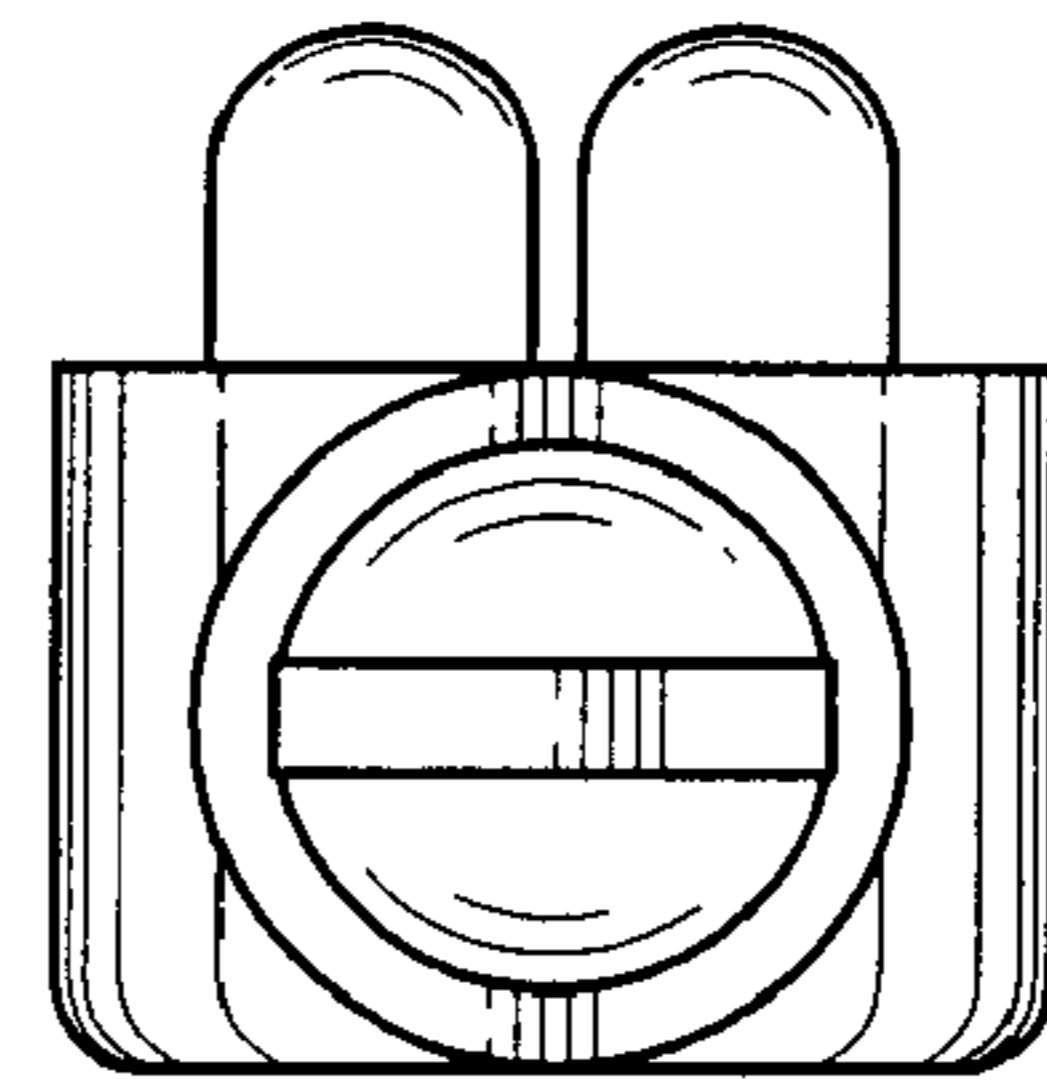

FIG. 4

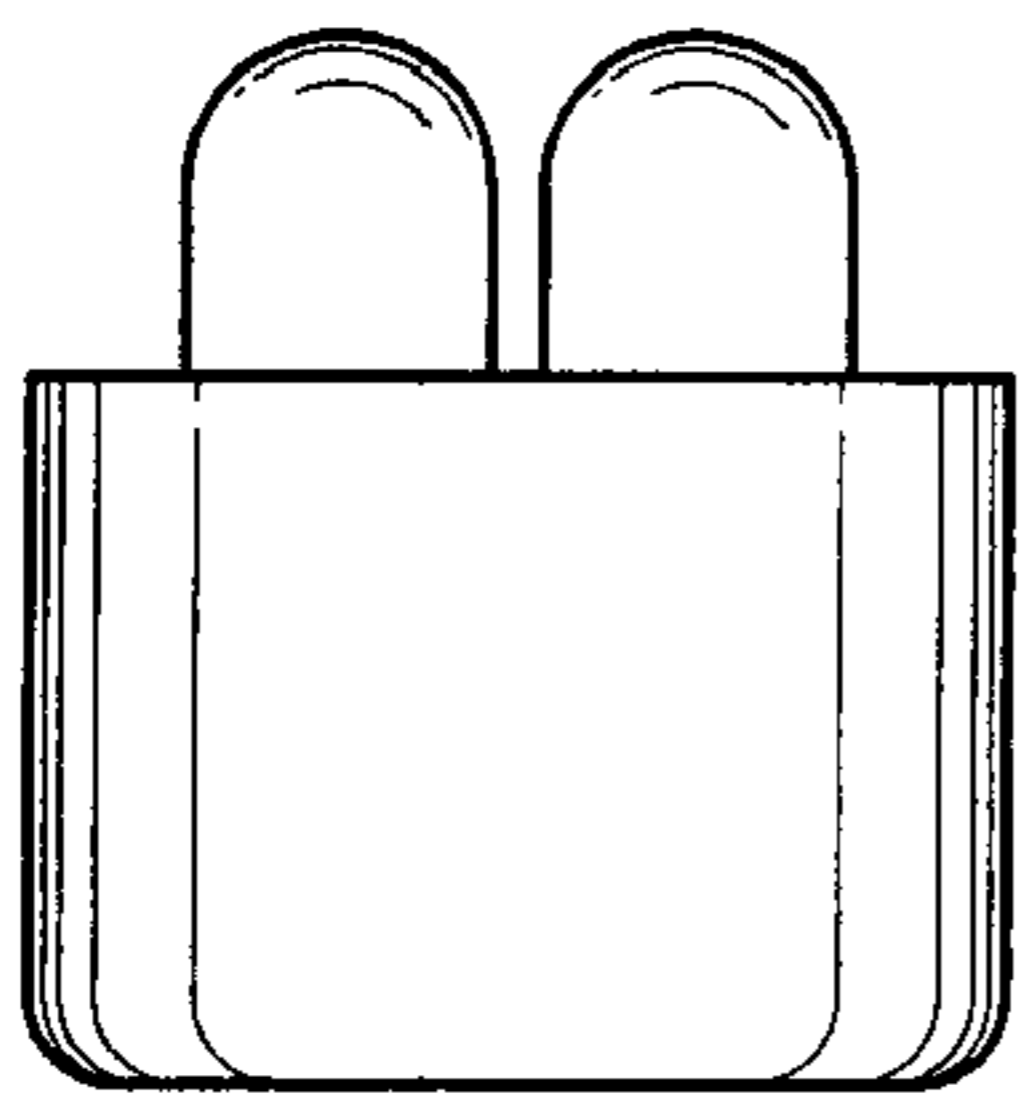

FIG. 5

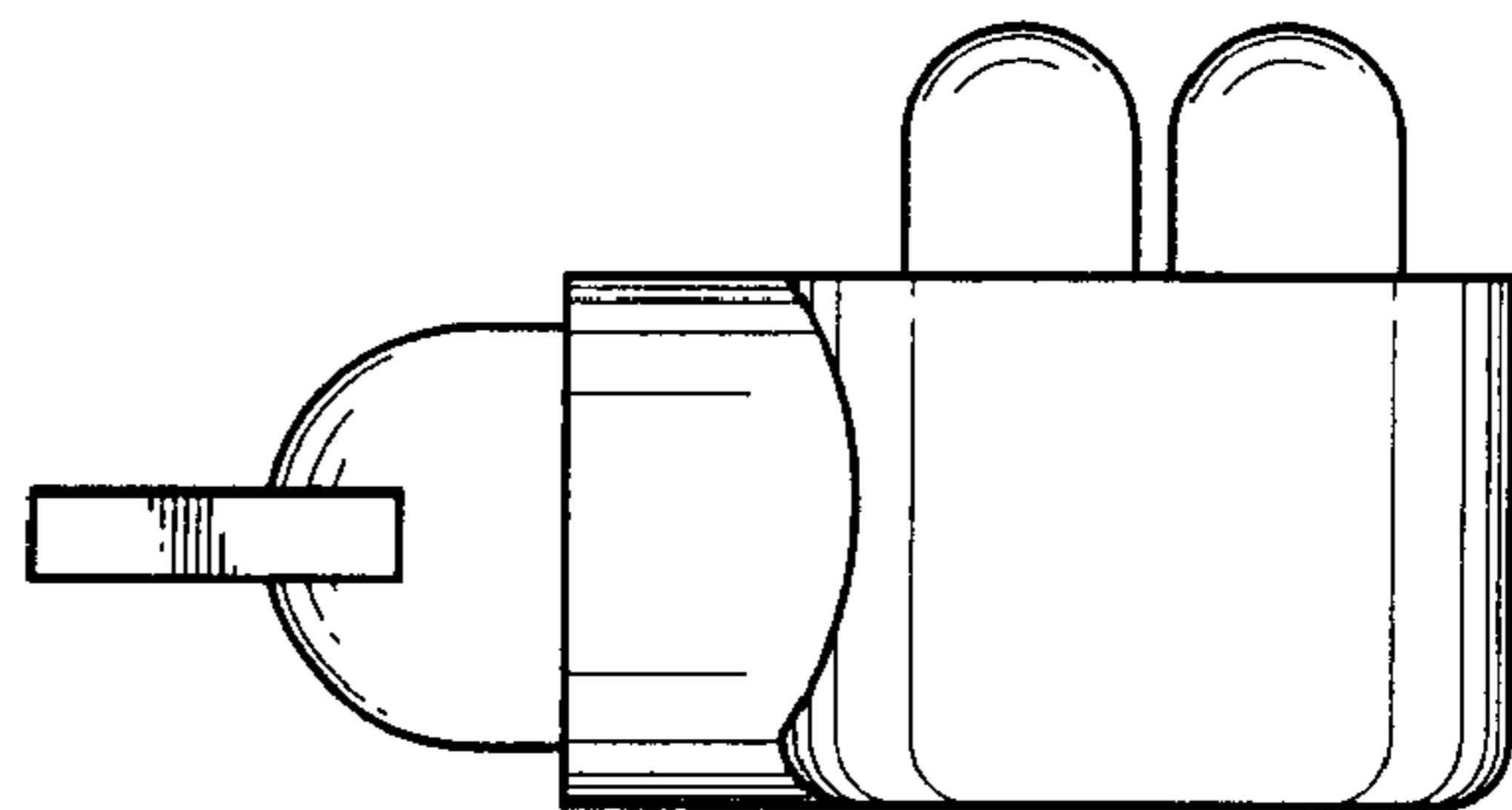

FIG. 6

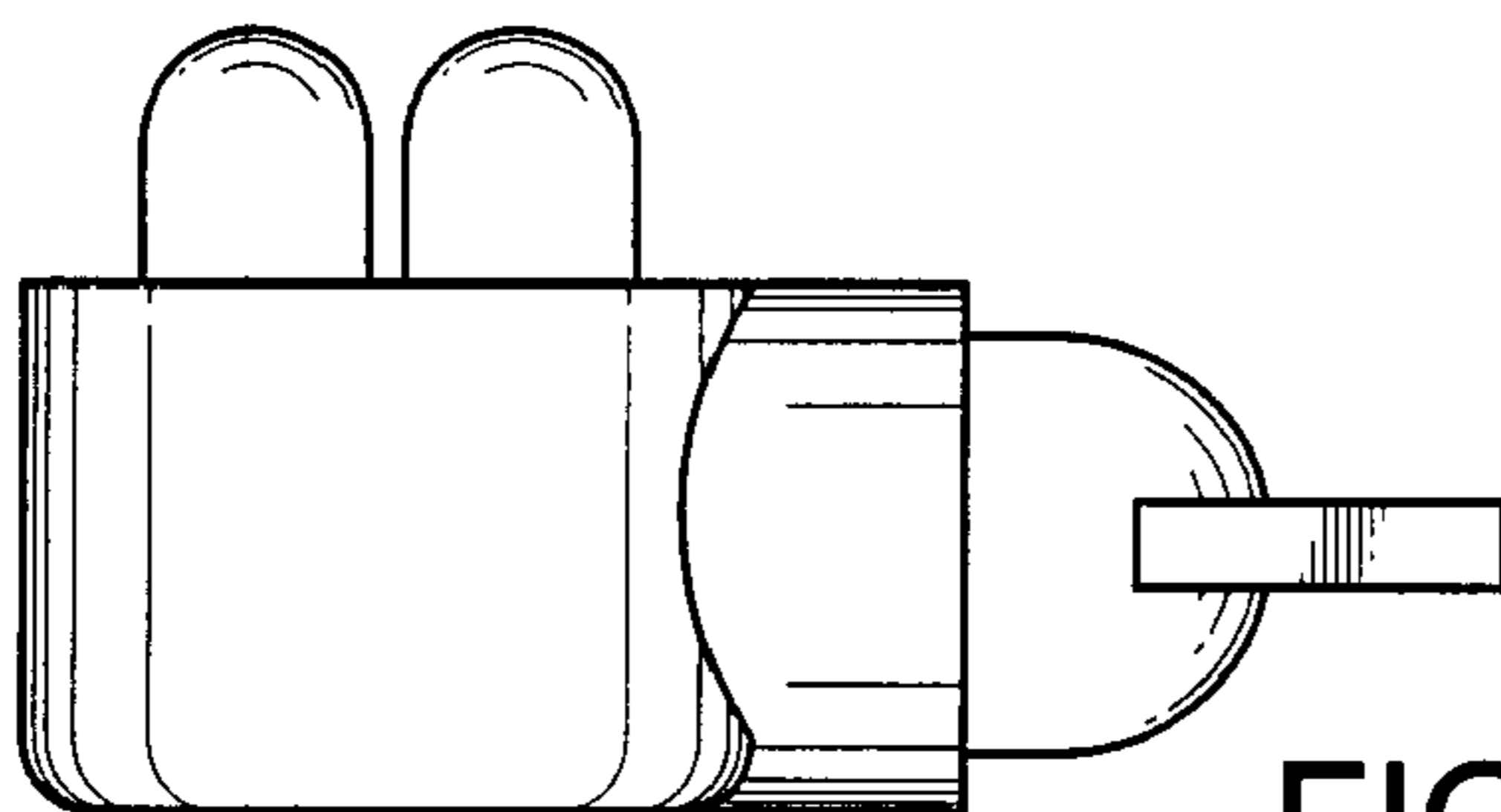

FIG. 7

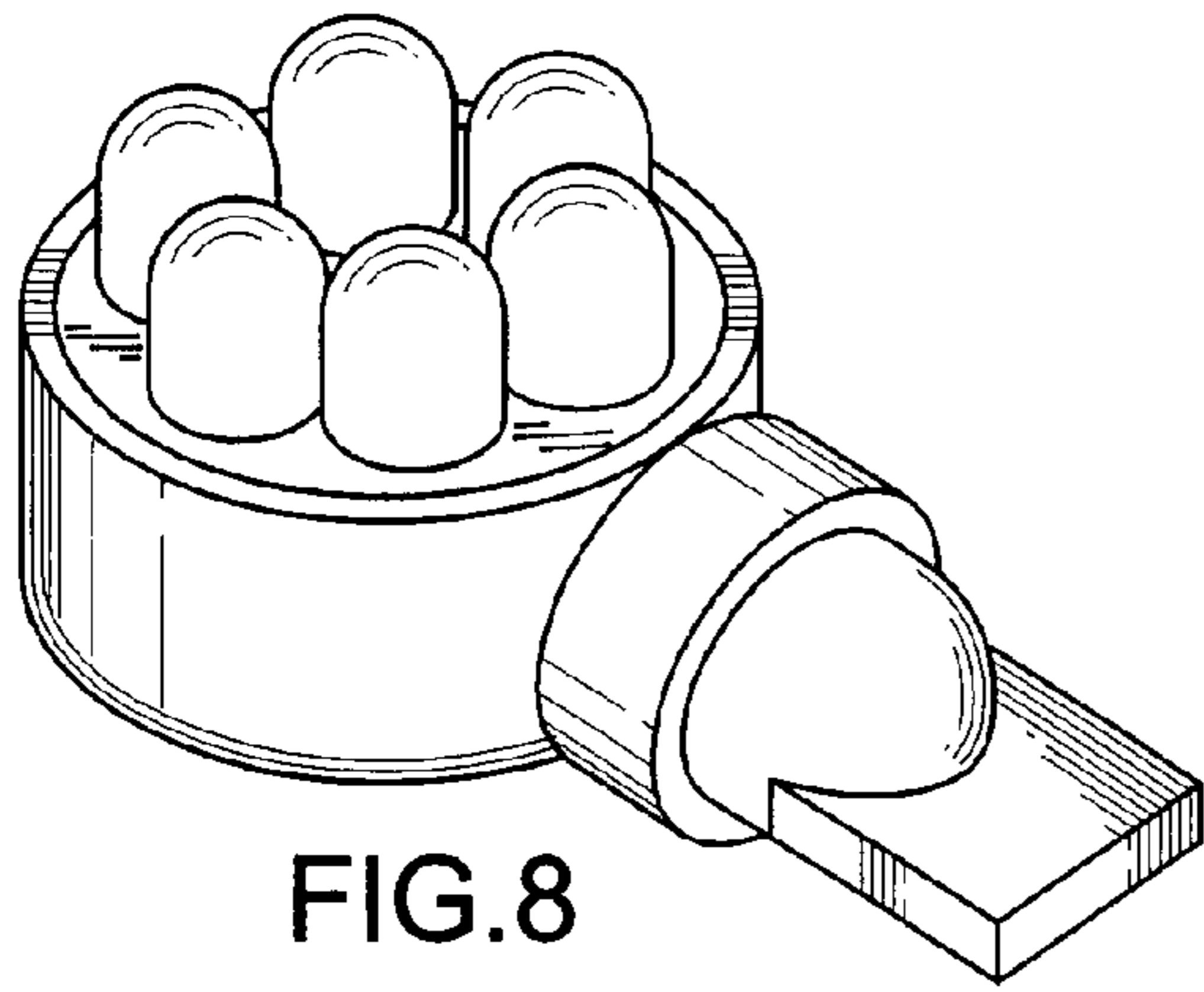

FIG. 8

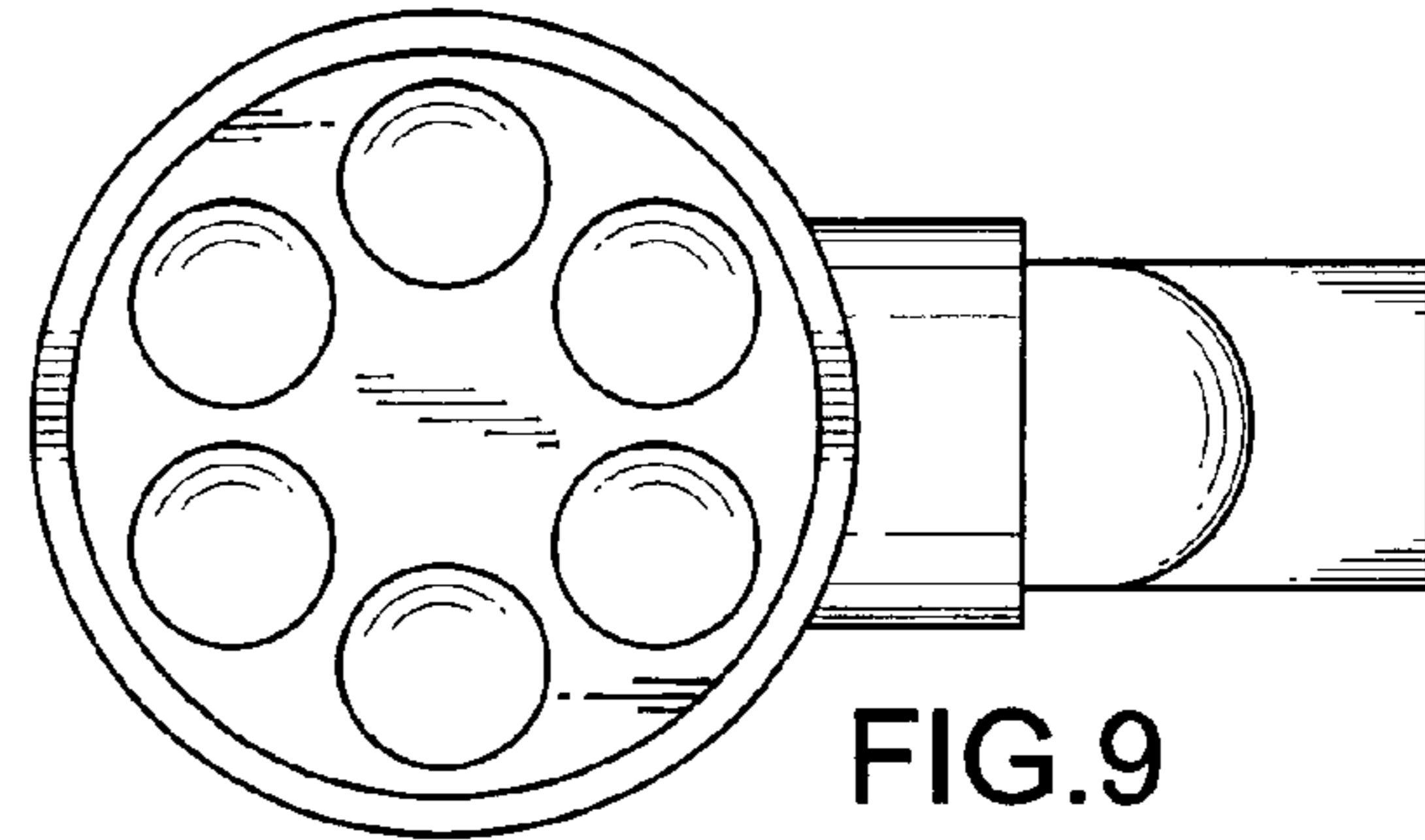

FIG. 9

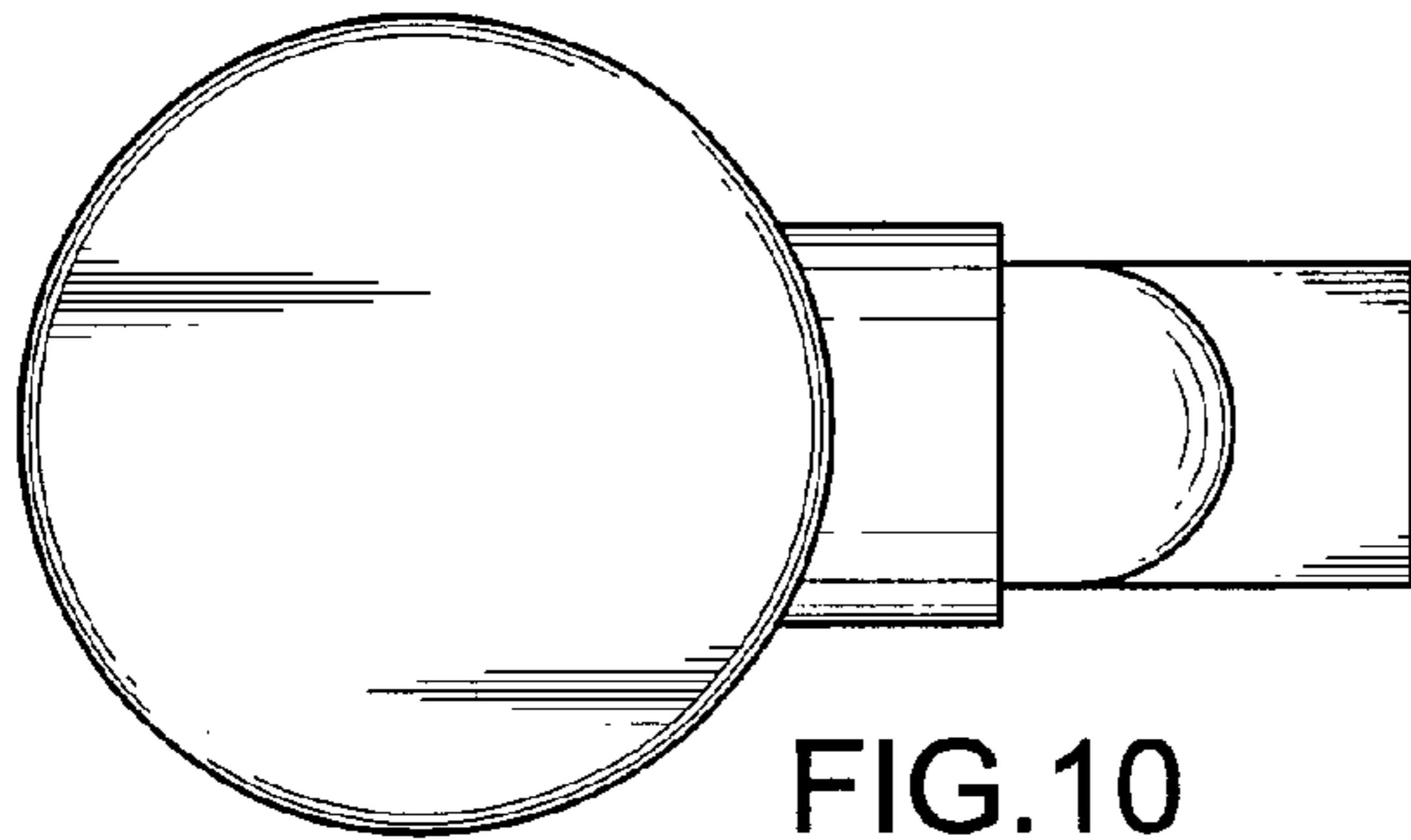

FIG. 10

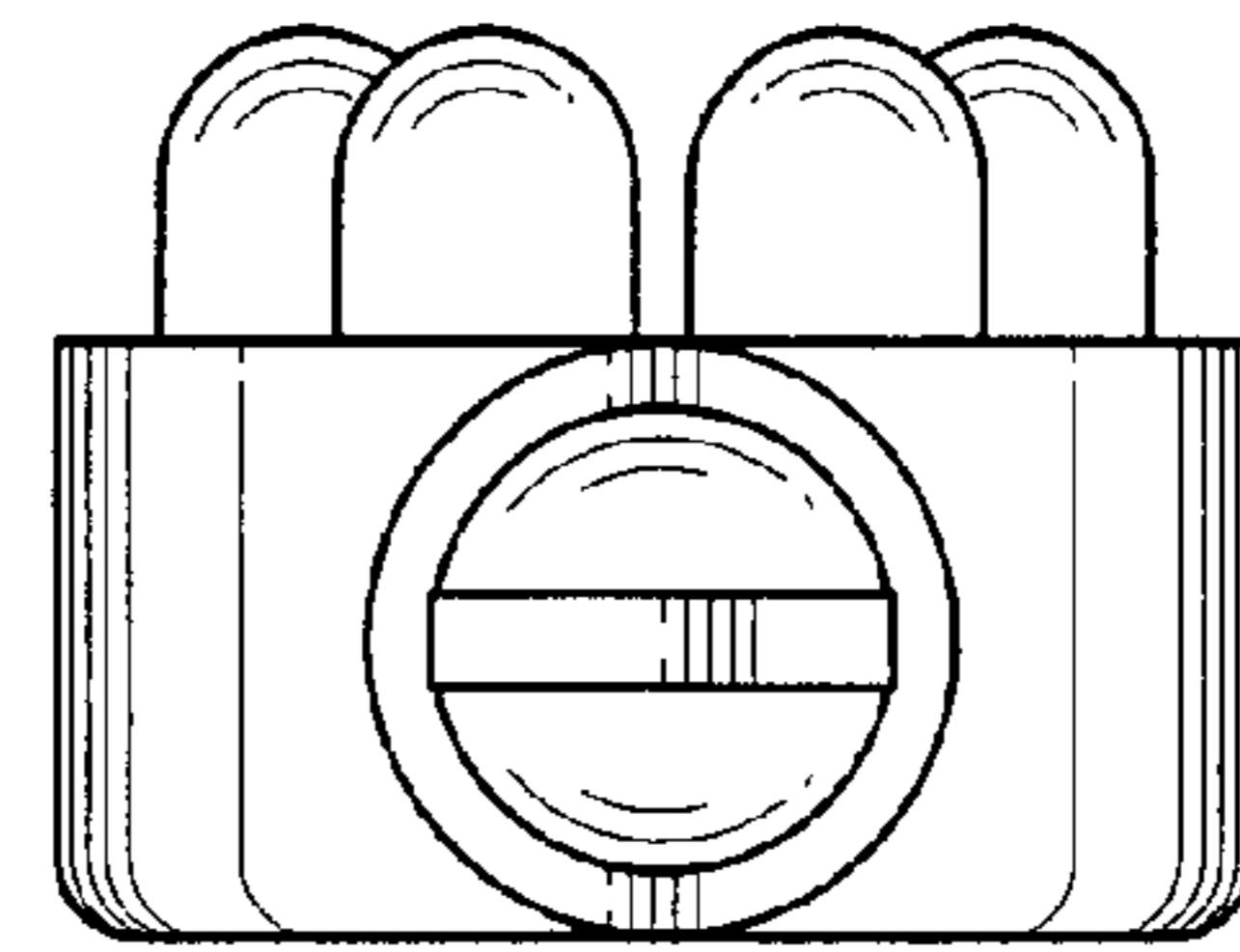

FIG. 11

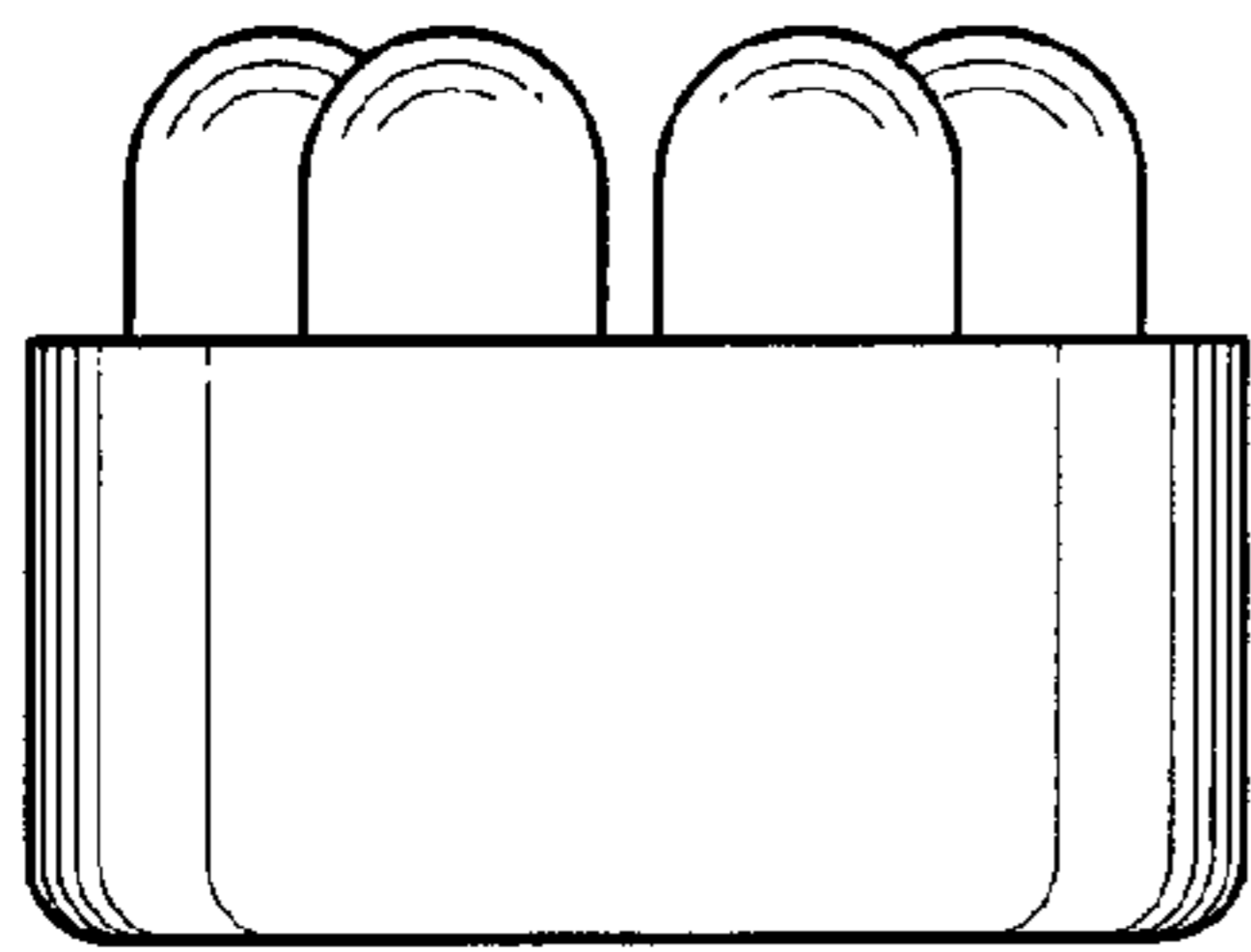

FIG. 12

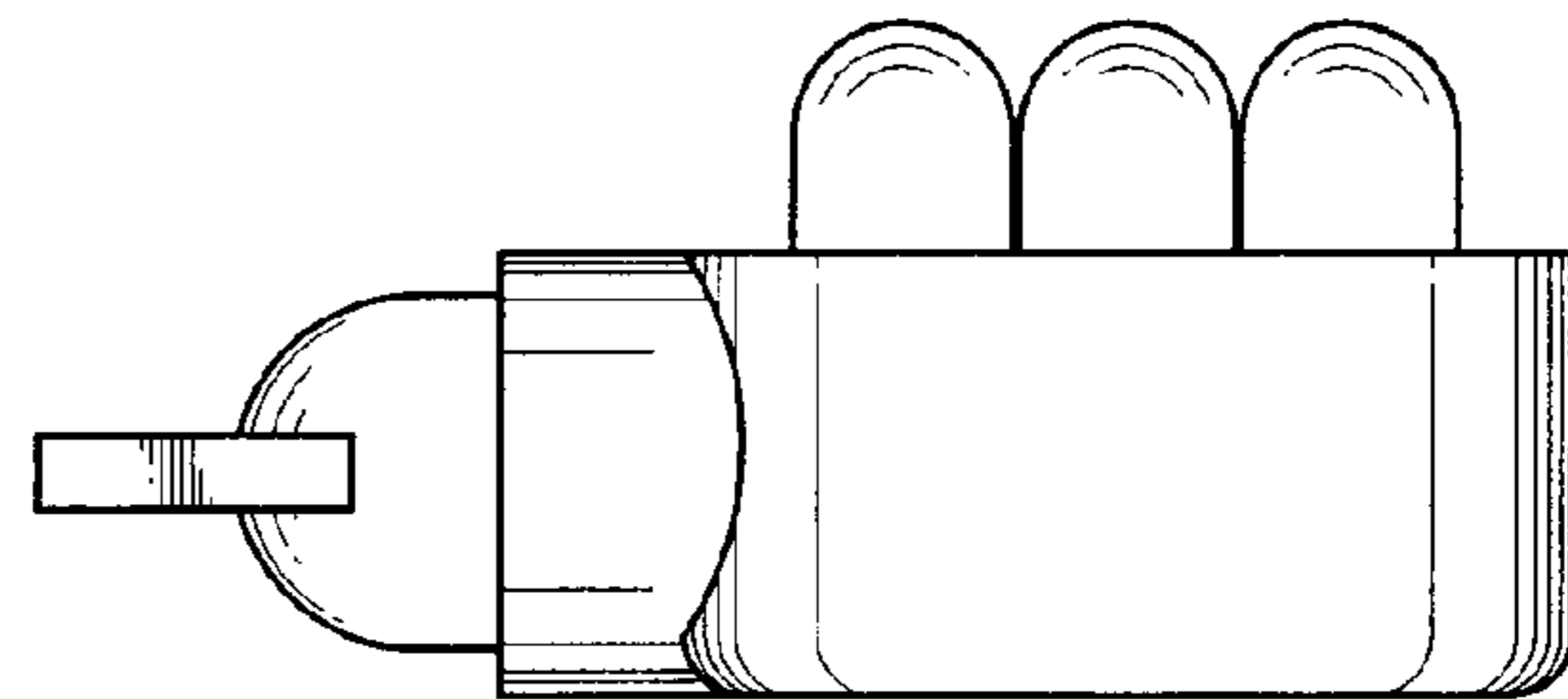

FIG. 13

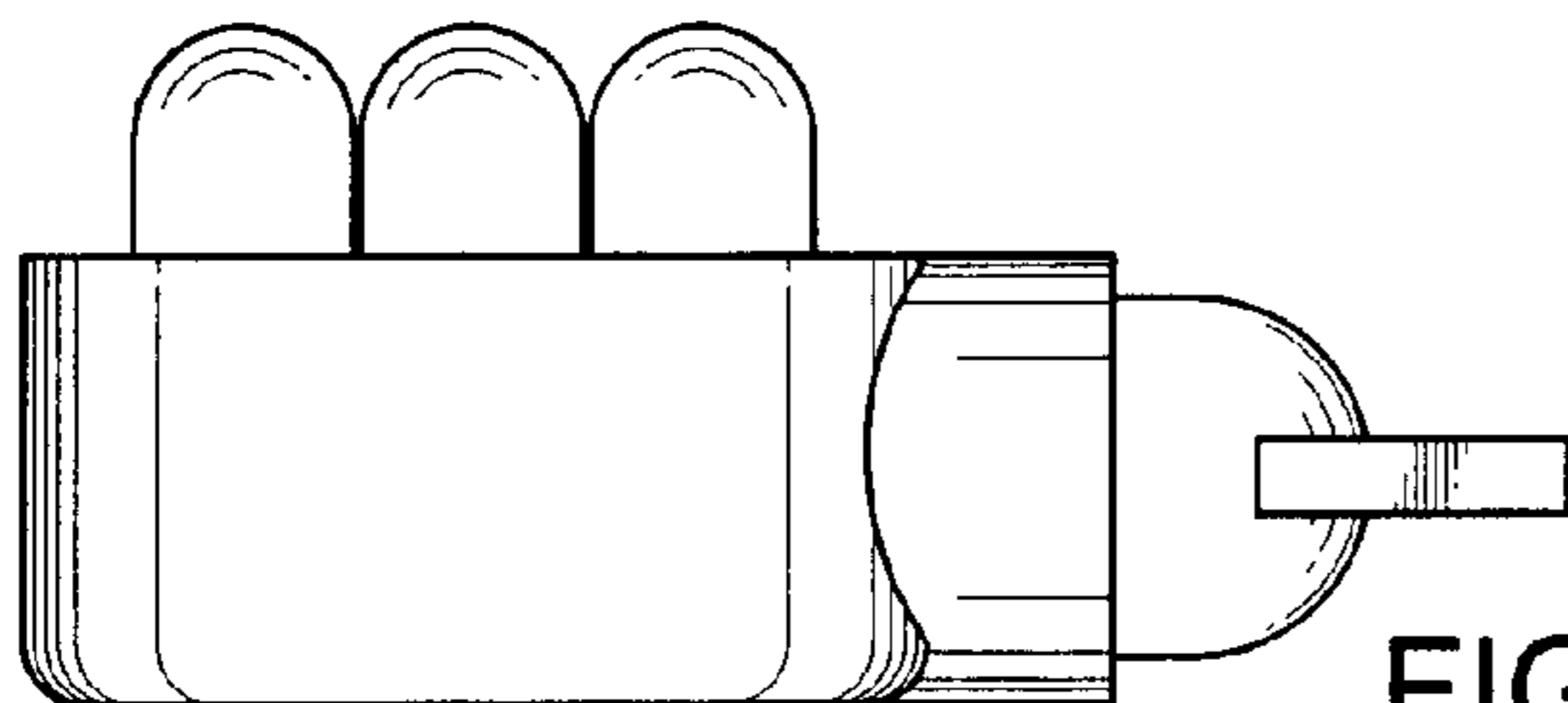

FIG. 14

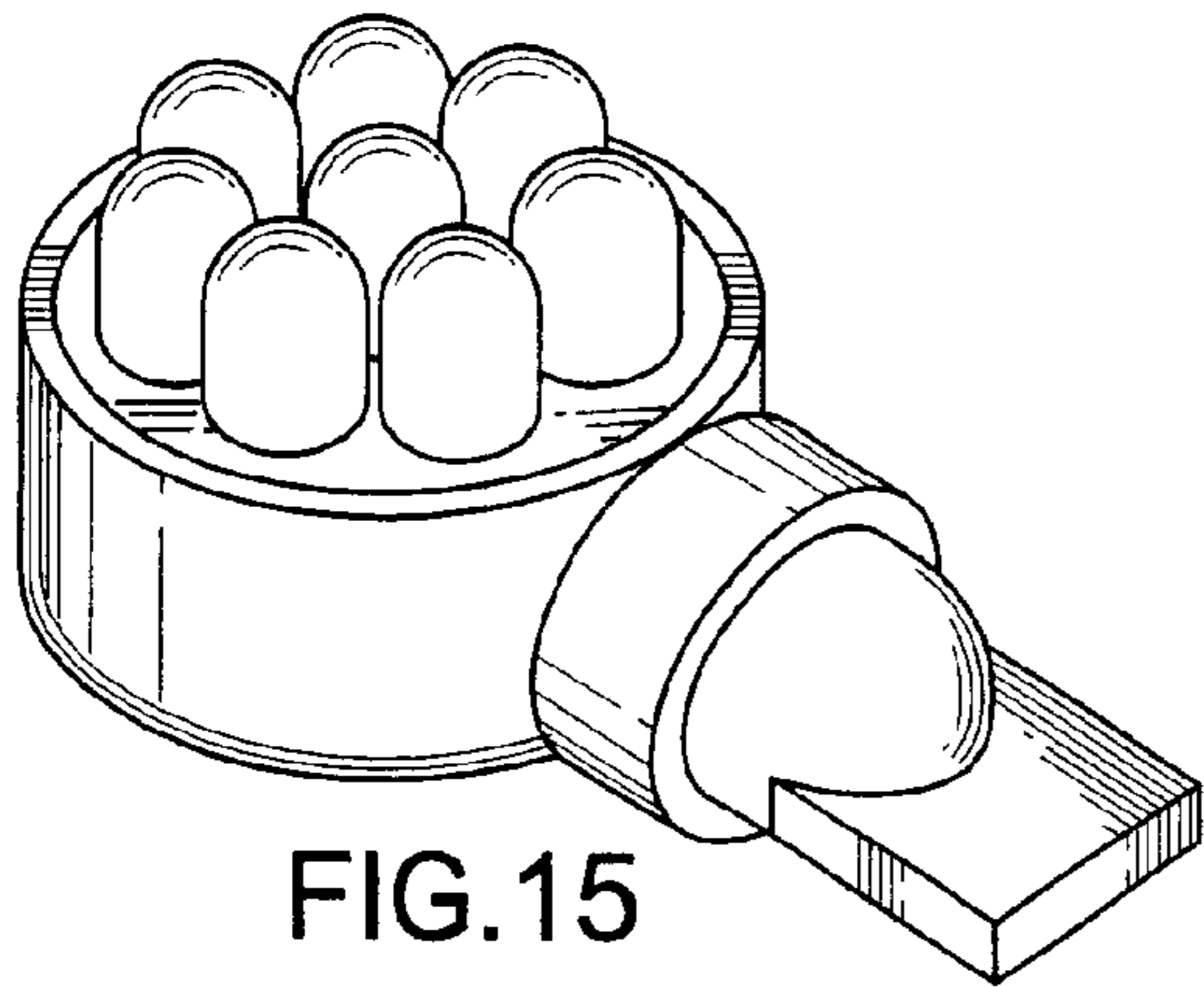

FIG. 15

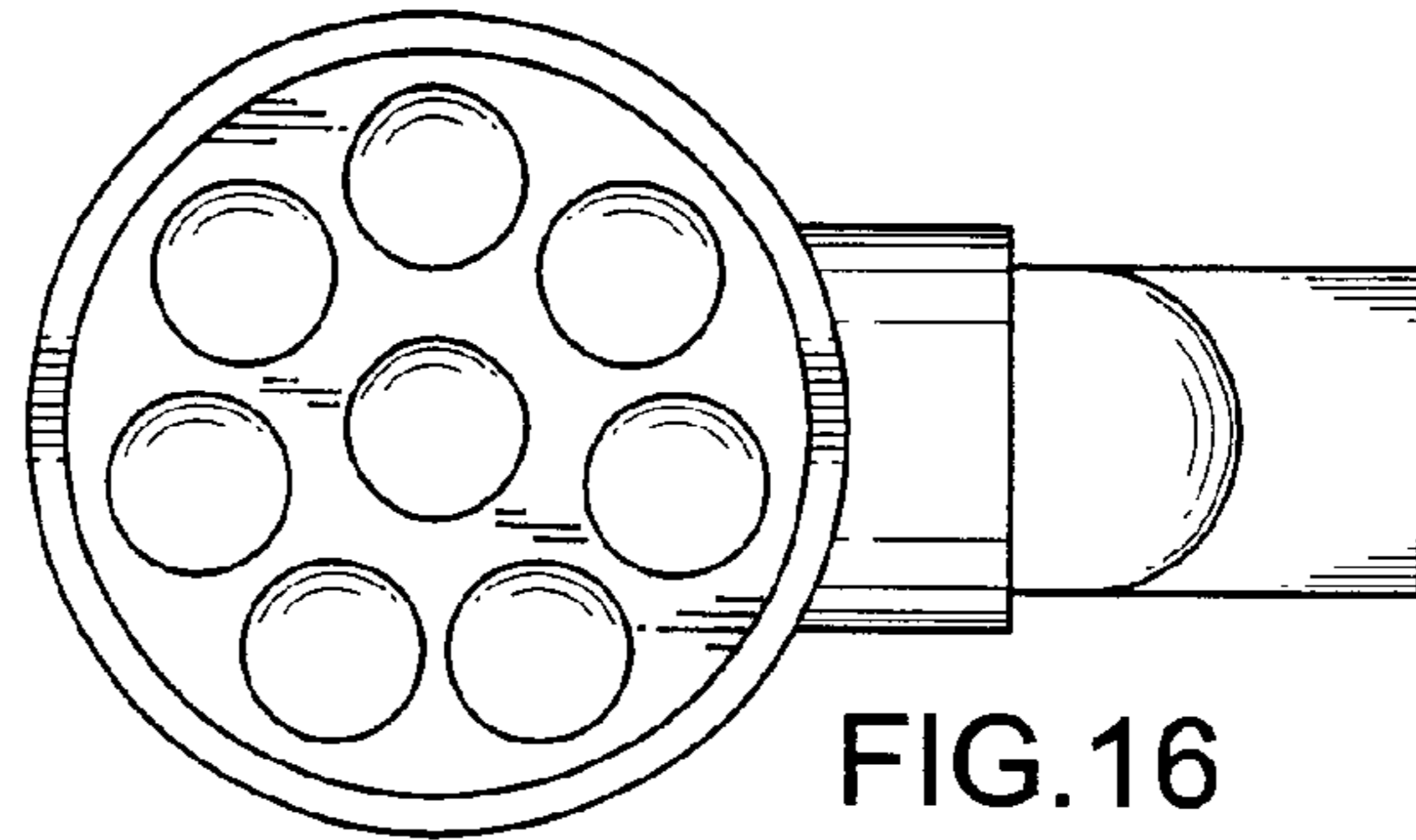

FIG. 16

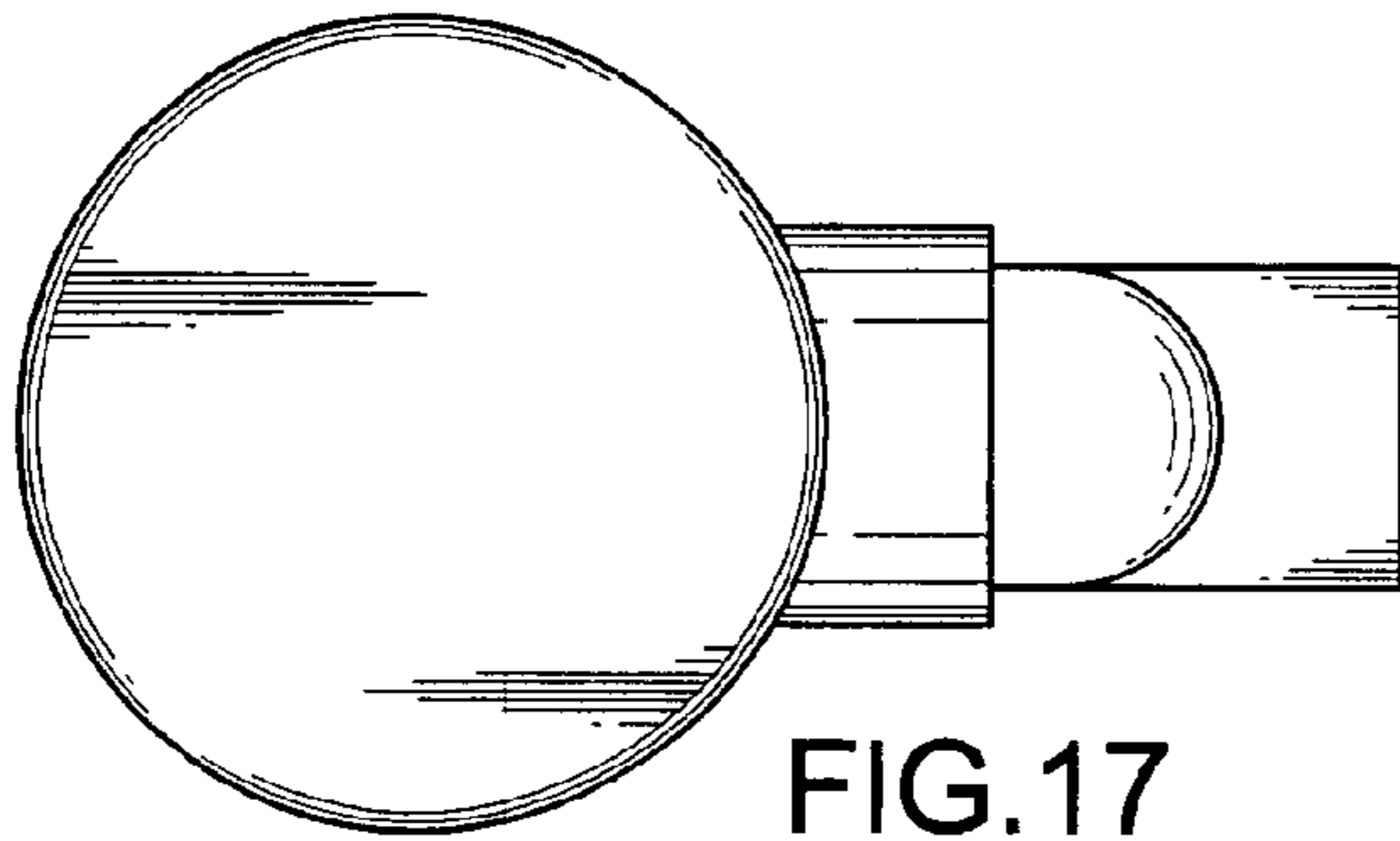

FIG. 17

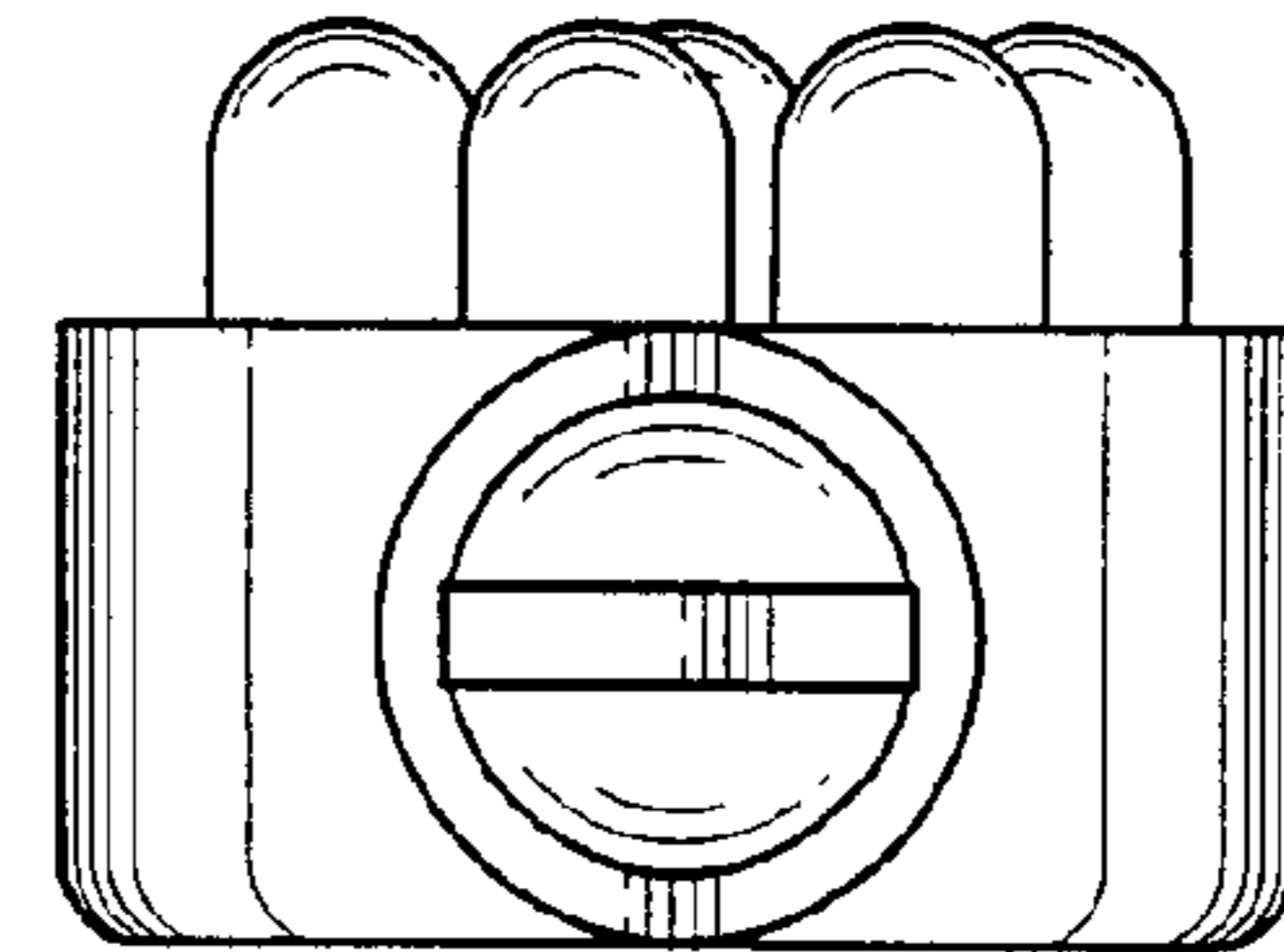

FIG. 18

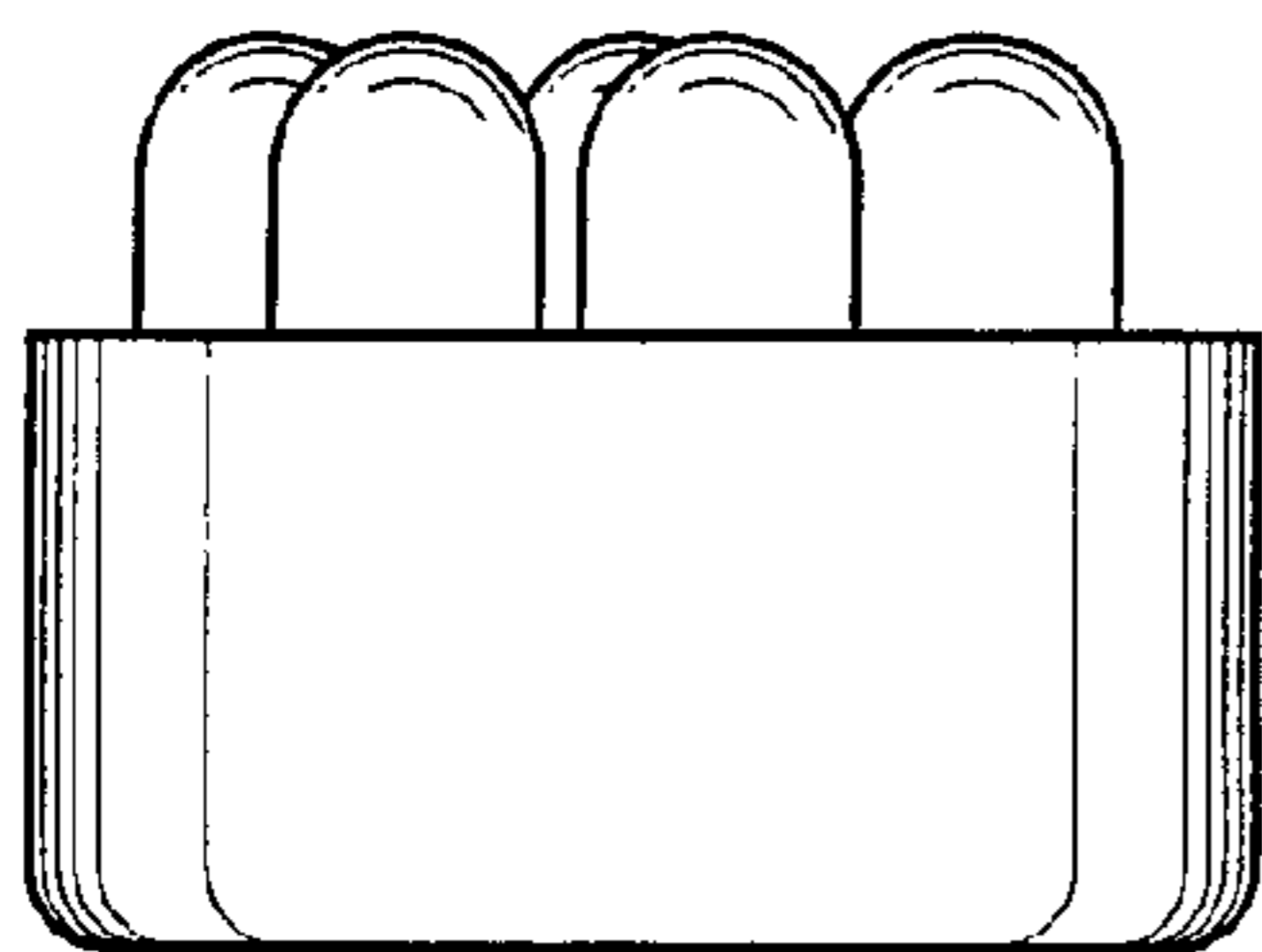

FIG. 19

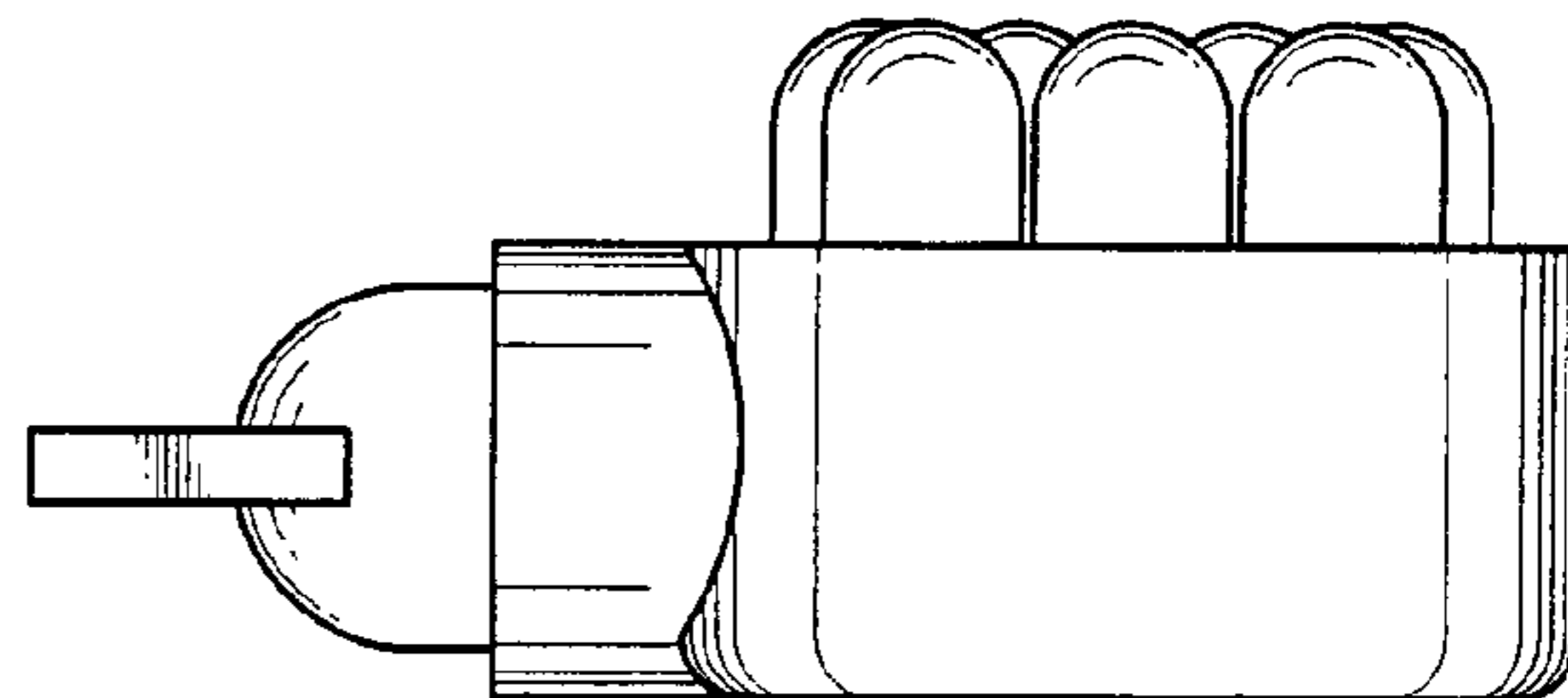

FIG. 20

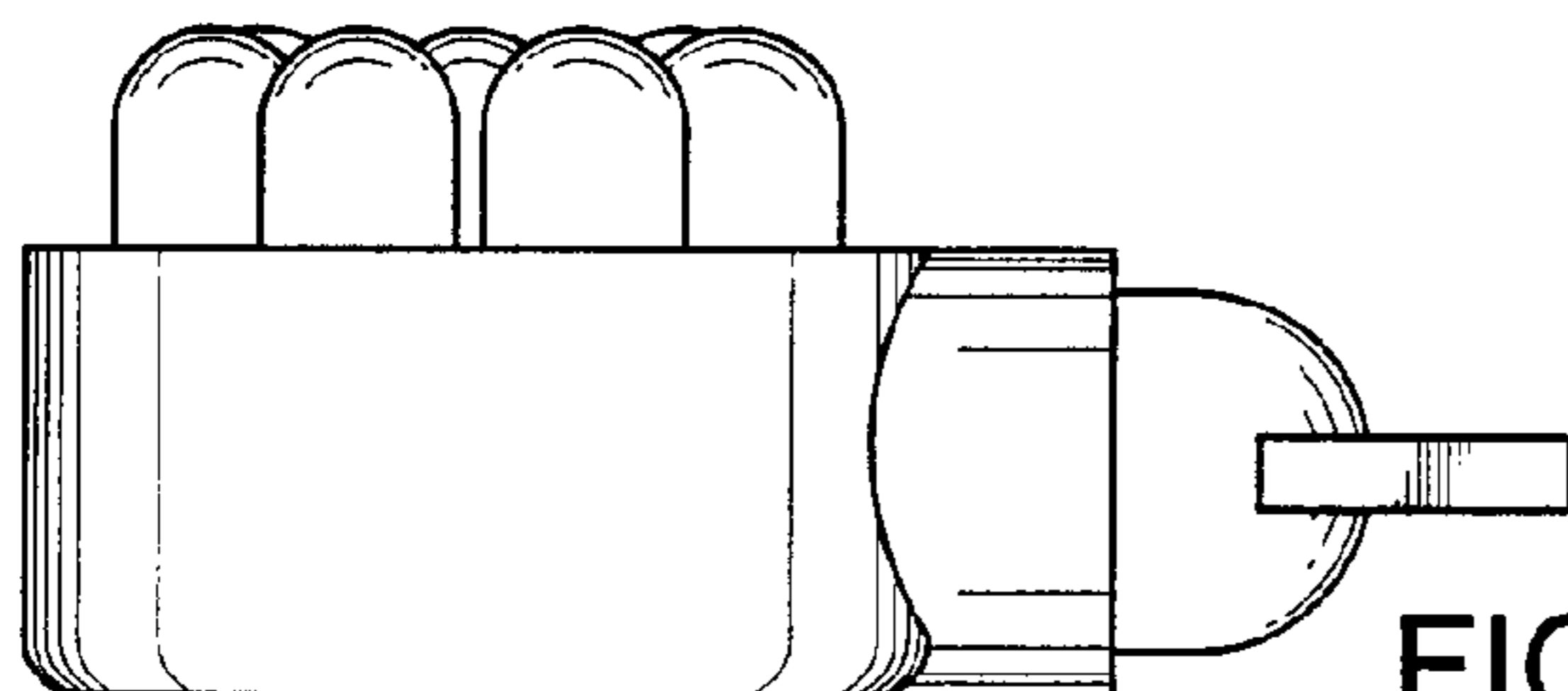

FIG. 21