

US00D509469S

(12) **United States Design Patent**
Longpré et al.

(10) **Patent No.: US D509,469 S**

(45) **Date of Patent: ** Sep. 13, 2005**

(54) **BOAT**

(75) Inventors: **Guillaume Longpré**, Brossard (CA);
Martin Aubé, St-Bruno-de-Montarville
(CA); **Stephane Sanschagrín**,
St-Hyacinthe (CA); **Luc Bourgeois**,
St-Hubert (CA); **Etienne Guay**,
St-Bruno (CA); **Joseph Ellice**,
St-Lambert (CA); **Richard E. Eck**,
Minneapolis, MN (US)

(73) Assignee: **Bombardier Recreational Products,**
Inc., Valcourt (CA)

(**) Term: **14 Years**

(21) Appl. No.: **29/185,555**

(22) Filed: **Jul. 1, 2003**

(51) **LOC (8) Cl.** **12-06**

(52) **U.S. Cl.** **D12/300**

(58) **Field of Search** D12/300, 317,
D12/318; 114/56.1, 57, 361, 363, 364,
343, 355

(56) **References Cited**

U.S. PATENT DOCUMENTS

D322,240 S * 12/1991 Carlson D12/300
D343,161 S 1/1994 Lapointe D12/307

D375,479 S 11/1996 Lapointe et al. D12/307
D400,844 S 11/1998 Lapointe et al. D12/300
D409,555 S 5/1999 Lapointe et al. D12/300
D453,955 S 2/2002 Aselton et al. D23/307
D462,931 S 9/2002 Aselton et al. D12/307
D482,648 S * 11/2003 Eck et al. D12/300

OTHER PUBLICATIONS

Bombardier Sea-Doo 2002 Boats Brochure, copyright 2001.

* cited by examiner

Primary Examiner—Holly Baynham

Assistant Examiner—Cynthia M. Chin

(74) *Attorney, Agent, or Firm*—BRP Legal Services

(57) **CLAIM**

The ornamental design for a boat, as shown and described.

DESCRIPTION

FIG. 1 is a perspective illustration, from the front and left side, of a boat according to our design;
FIG. 2 is a top plan view of the boat of FIG. 1;
FIG. 3 is a left side elevational view of the boat of FIG. 1;
FIG. 4 is a right side elevational view of the boat of FIG. 1;
FIG. 5 is a front elevational view of the boat of FIG. 1;
FIG. 6 is a rear elevational view of the boat of FIG. 1; and,
FIG. 7 is a bottom plan view of the boat of FIG. 1.

1 Claim, 6 Drawing Sheets

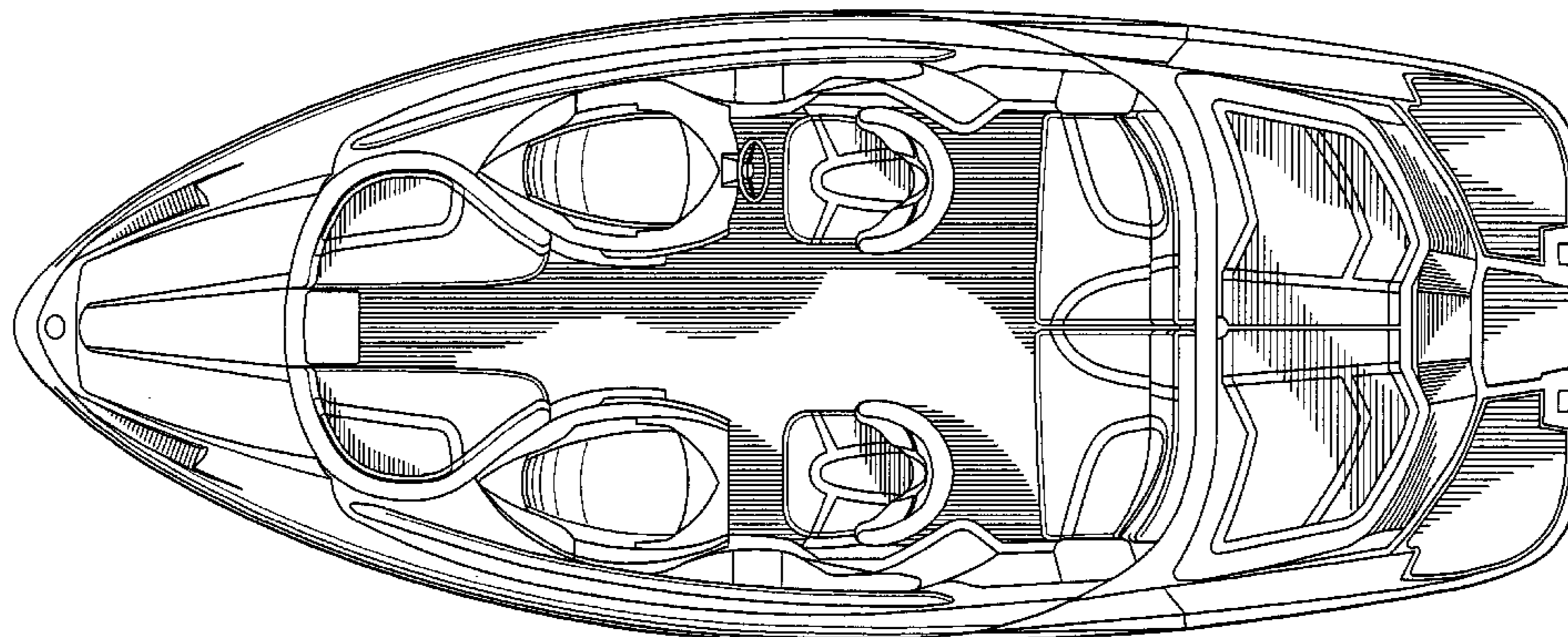
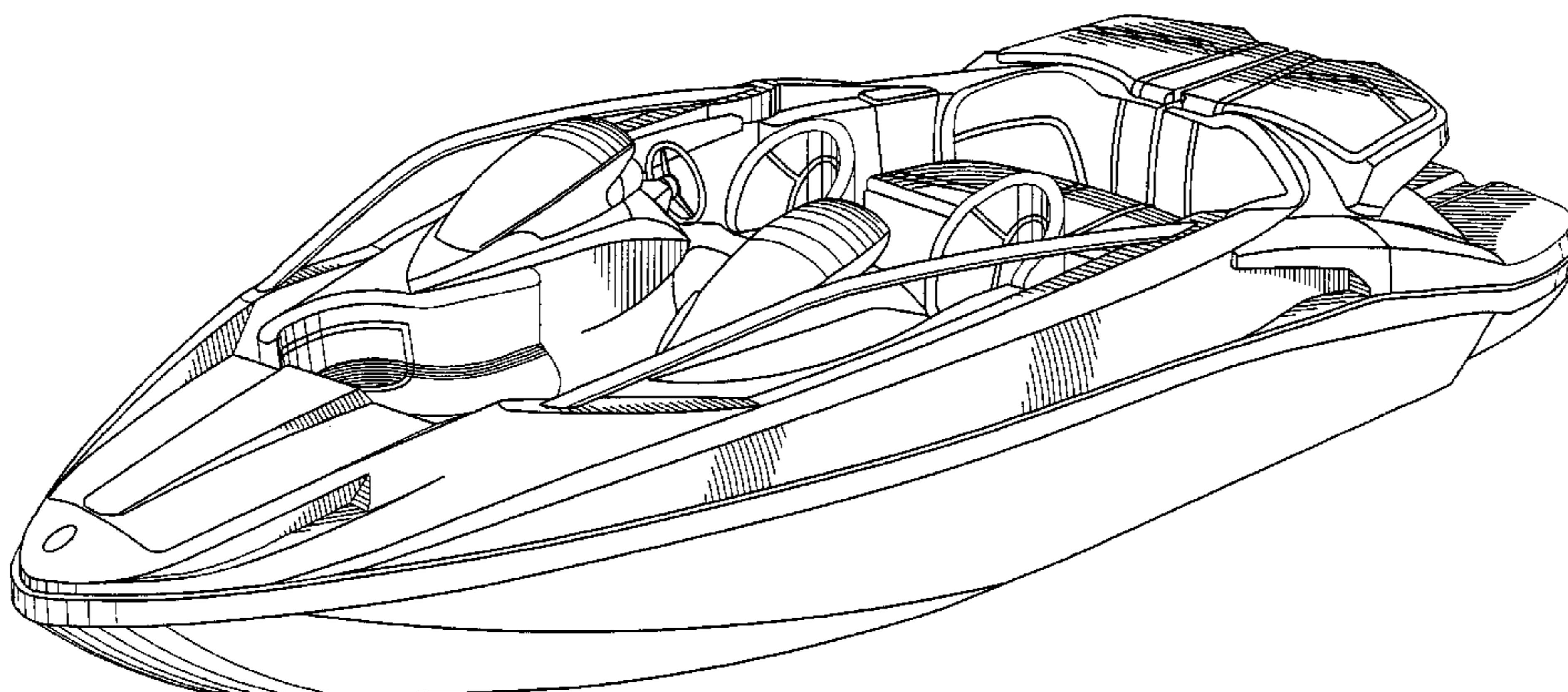

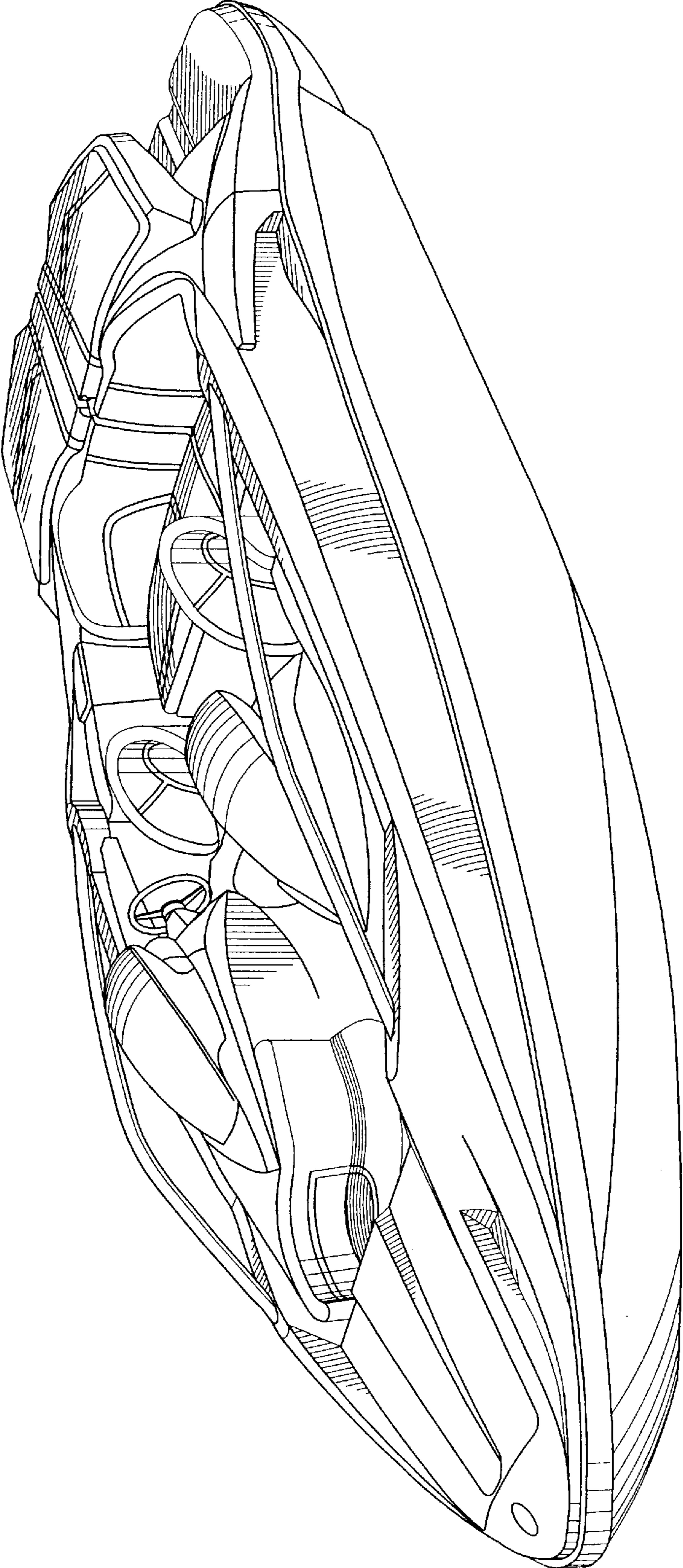

FIG. 1

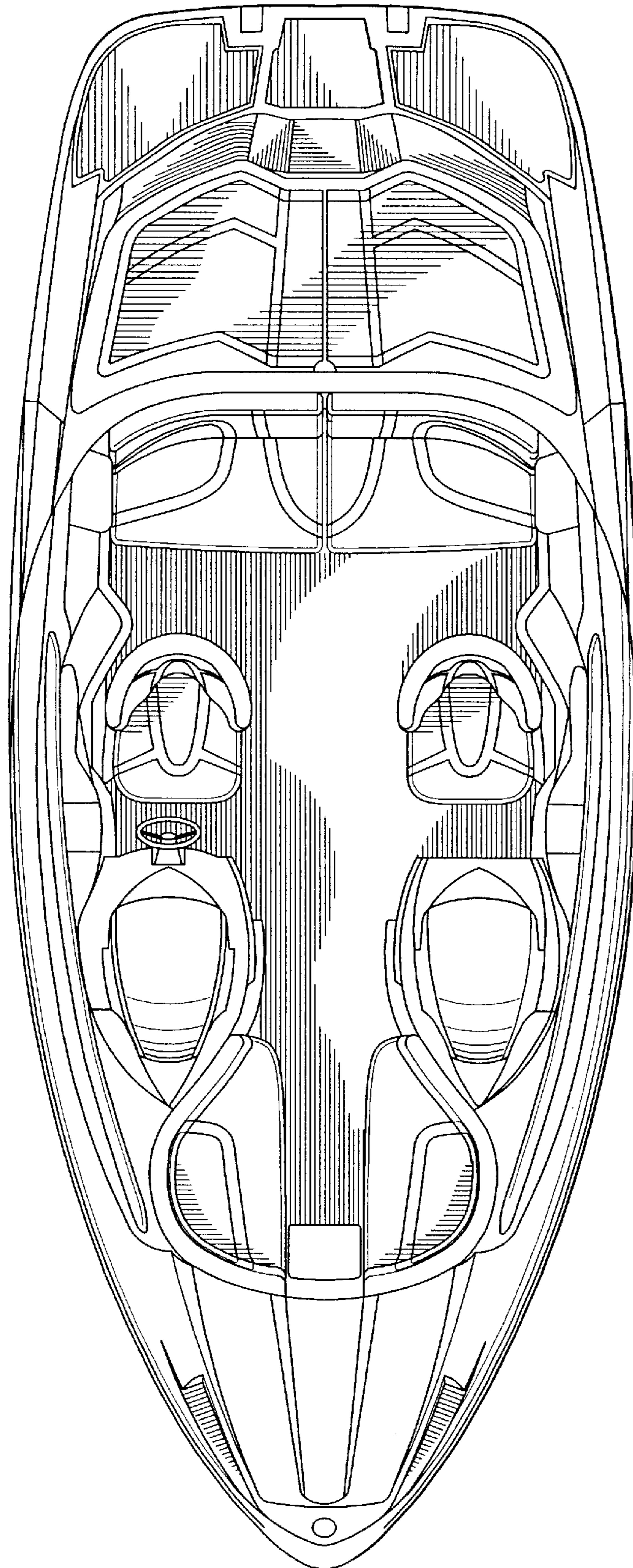

FIG. 2

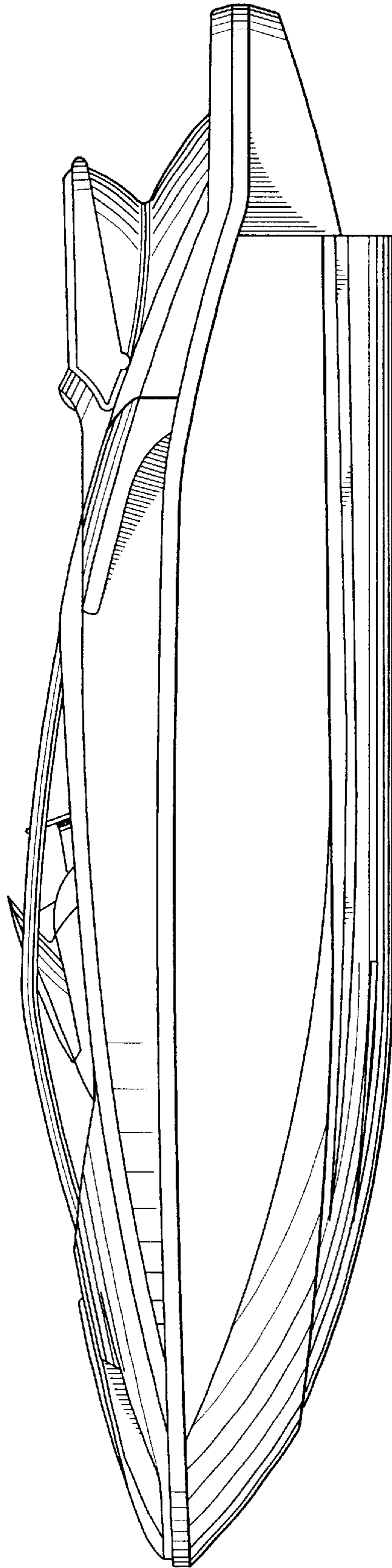

FIG. 3



FIG. 4

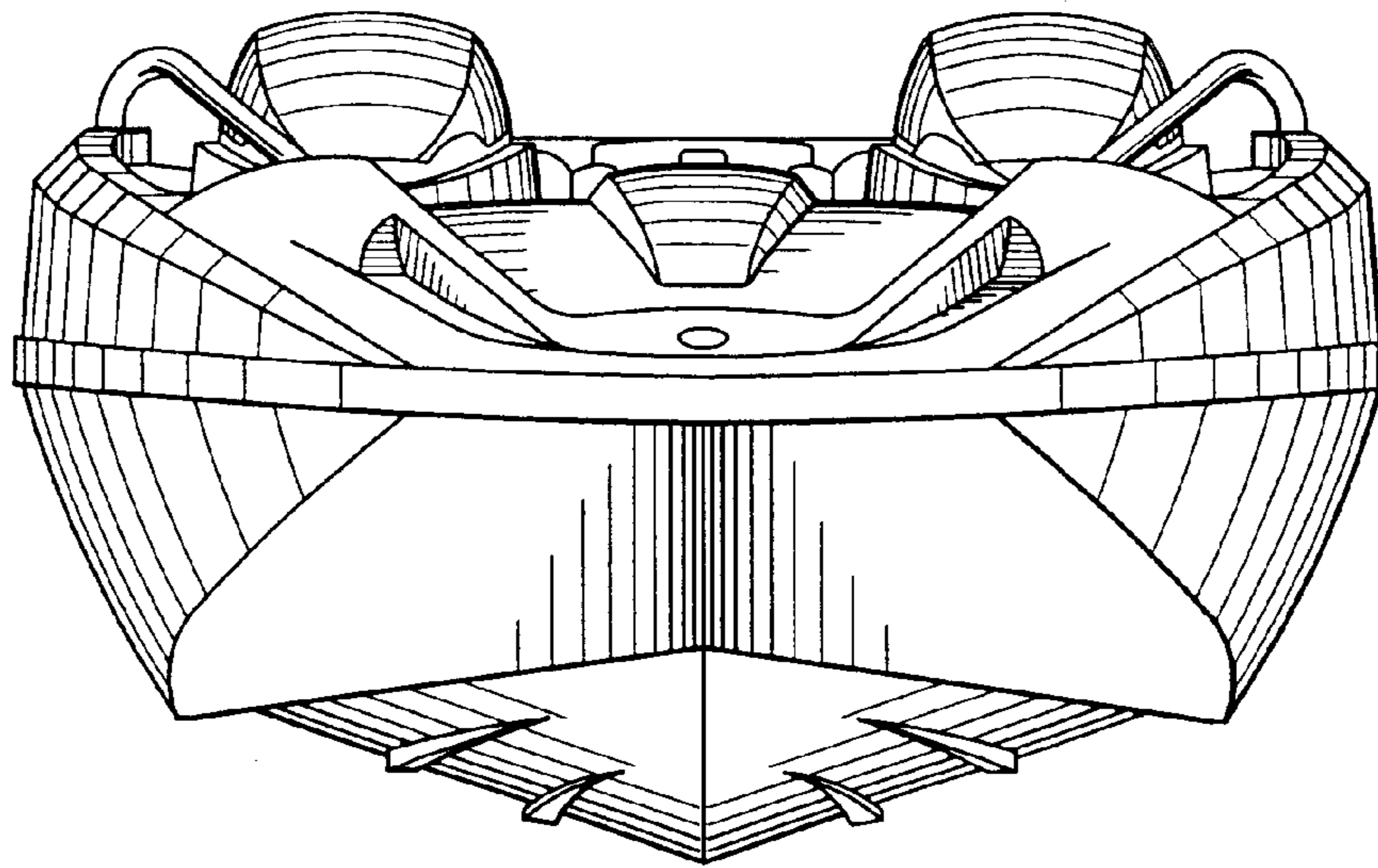

FIG. 5

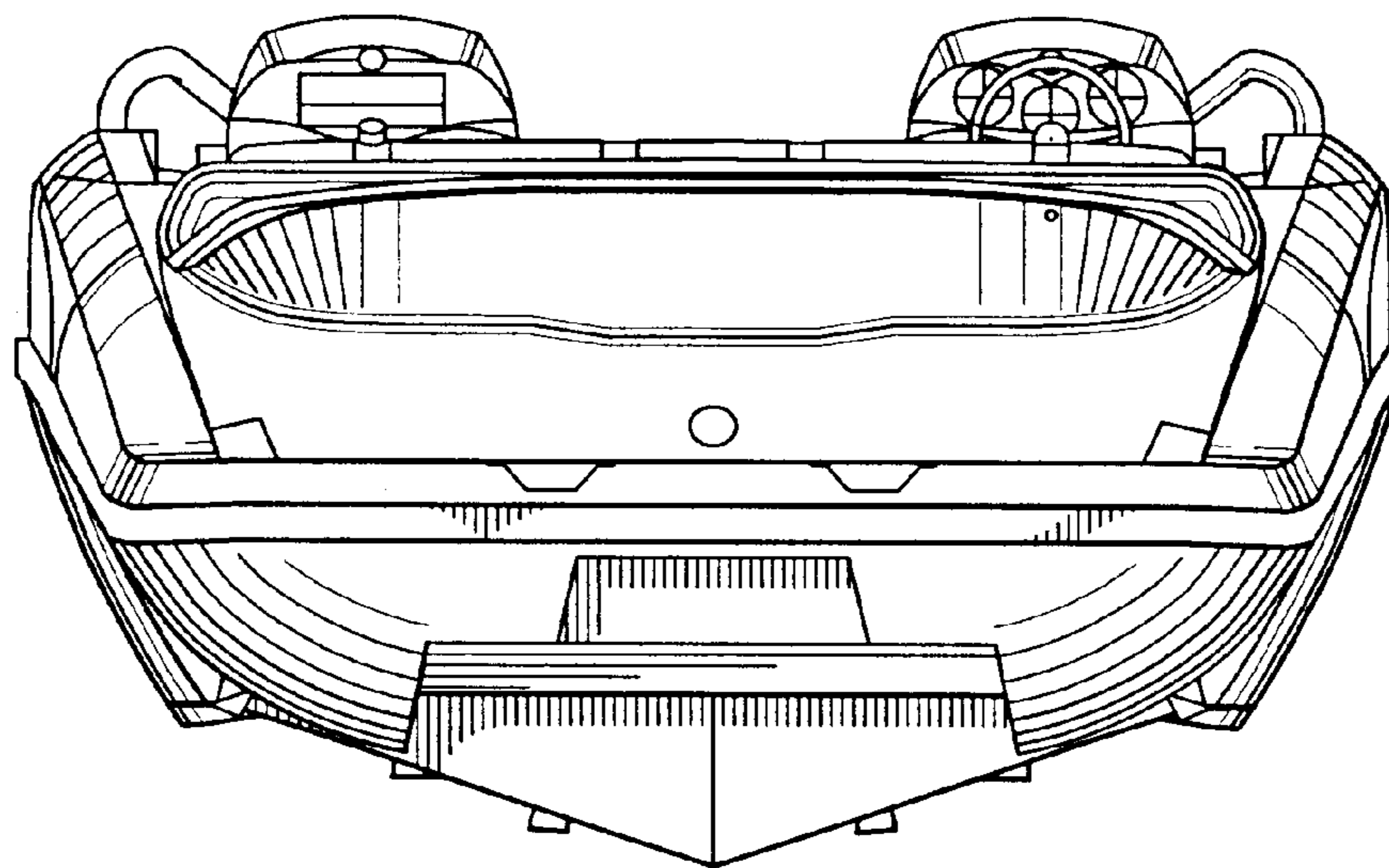

FIG. 6

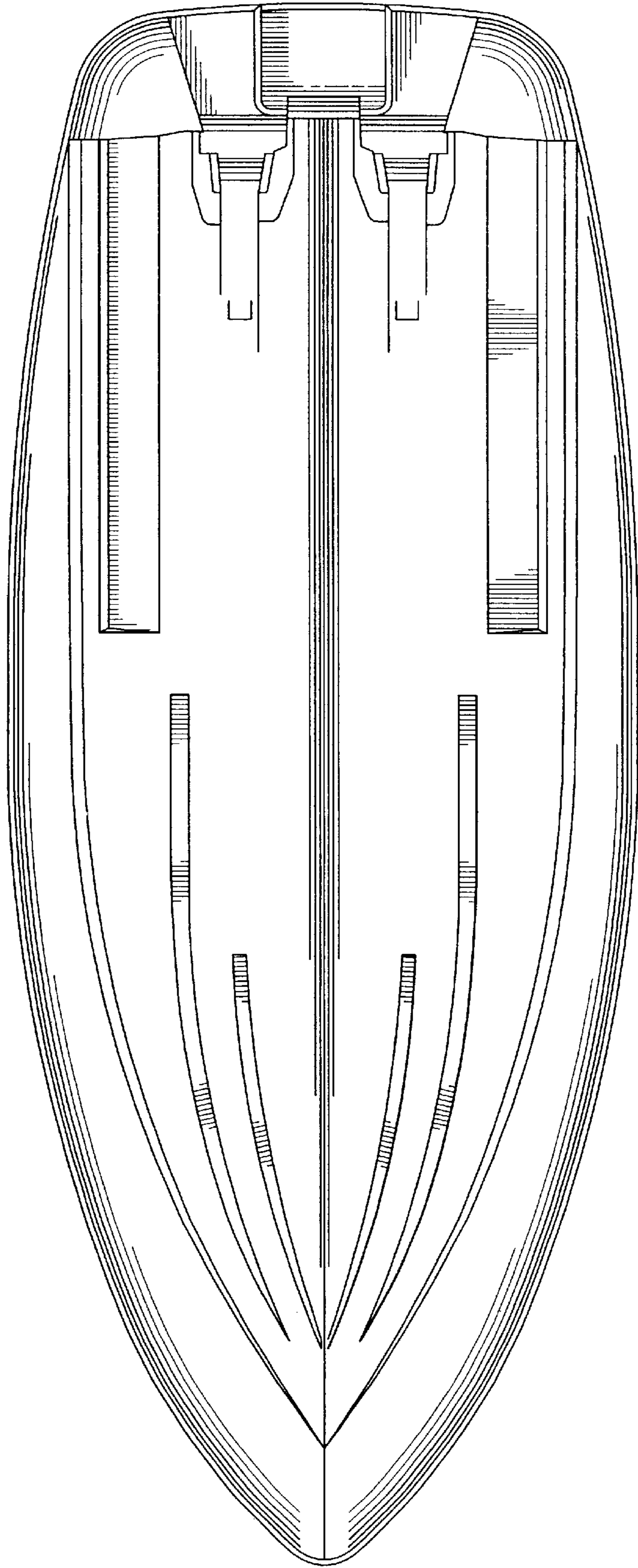

FIG. 7