

US00D509231S

(12) **United States Design Patent**
Hickenbottom

(10) **Patent No.:** **US D509,231 S**

(45) **Date of Patent:** **** Sep. 6, 2005**

(54) **HYDRAULIC SPLITTER**

(75) **Inventor:** **Ronald J. Hickenbottom**, Sullivan, IL (US)

(73) **Assignee:** **Agri-Fab, Inc.**, Sullivan, IL (US)

(**) **Term:** **14 Years**

(21) **Appl. No.:** **29/218,674**

(22) **Filed:** **Dec. 6, 2004**

(51) **LOC (8) Cl.** **15-09**

(52) **U.S. Cl.** **D15/127**

(58) **Field of Search** D15/127; 108/12,
108/19; 144/193.1-195.6, 366

(56) **References Cited**

U.S. PATENT DOCUMENTS

4,800,937	A	*	1/1989	Mangus, Sr.	144/195.1
5,373,877	A	*	12/1994	Chapman	144/195.1
5,526,855	A	*	6/1996	Graham	144/195.1
D381,994	S	*	8/1997	Weirick	D15/127

* cited by examiner

Primary Examiner—Antoine D. Davis

(74) *Attorney, Agent, or Firm*—Vedder Price Kaufman & Kammholz

(57) **CLAIM**

The ornamental design for a hydraulic splitter, as shown.

DESCRIPTION

FIG. 1 is a perspective view of the hydraulic splitter showing my new design;
 FIG. 2 is a front view of my design;
 FIG. 3 is a rear view of my design;
 FIG. 4 is a view of one side of my design;
 FIG. 5 is a view of the other side my design;
 FIG. 6 is a top view of my design;
 FIG. 7 is a bottom view of my design;
 FIG. 8 is perspective view of the second embodiment of my design;
 FIG. 9 is a front view of the second embodiment of my design;
 FIG. 10 is a rear view of the second embodiment of my design;
 FIG. 11 is a view of one side of the second embodiment of my design;
 FIG. 12 is view of the other side of the second embodiment of my design;
 FIG. 13 is a top view of the second embodiment of my design; and,
 FIG. 14 is a bottom view of the second embodiment of my design.

1 Claim, 6 Drawing Sheets

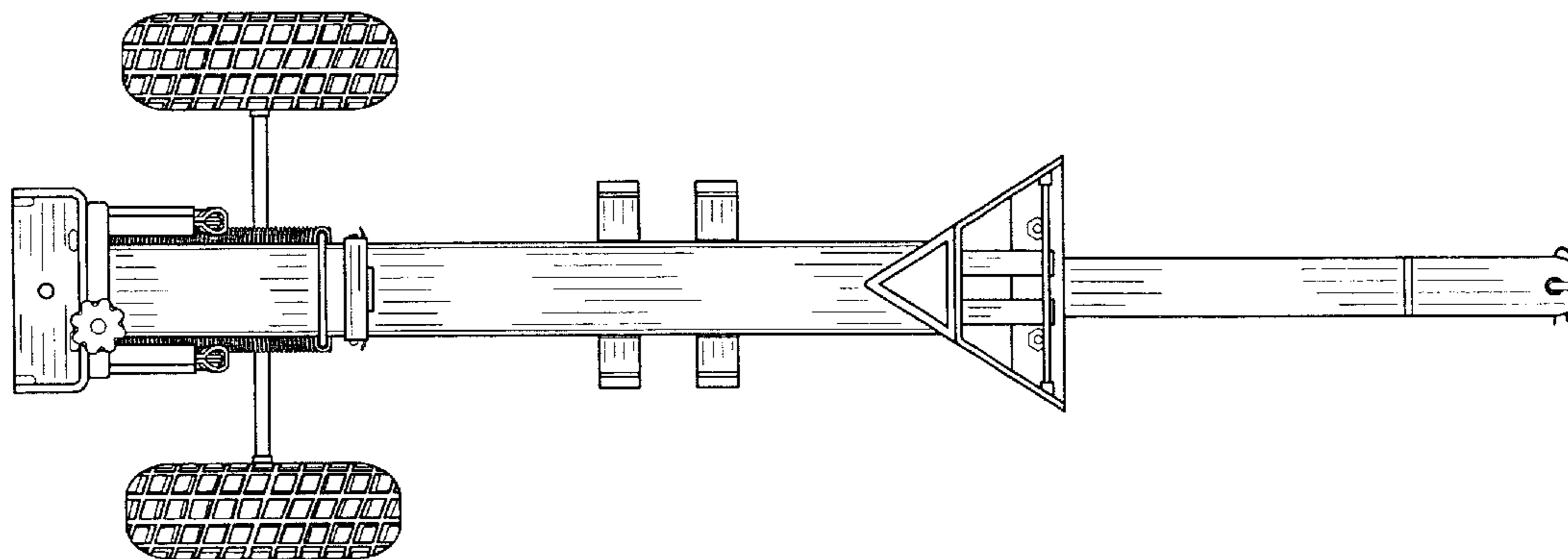

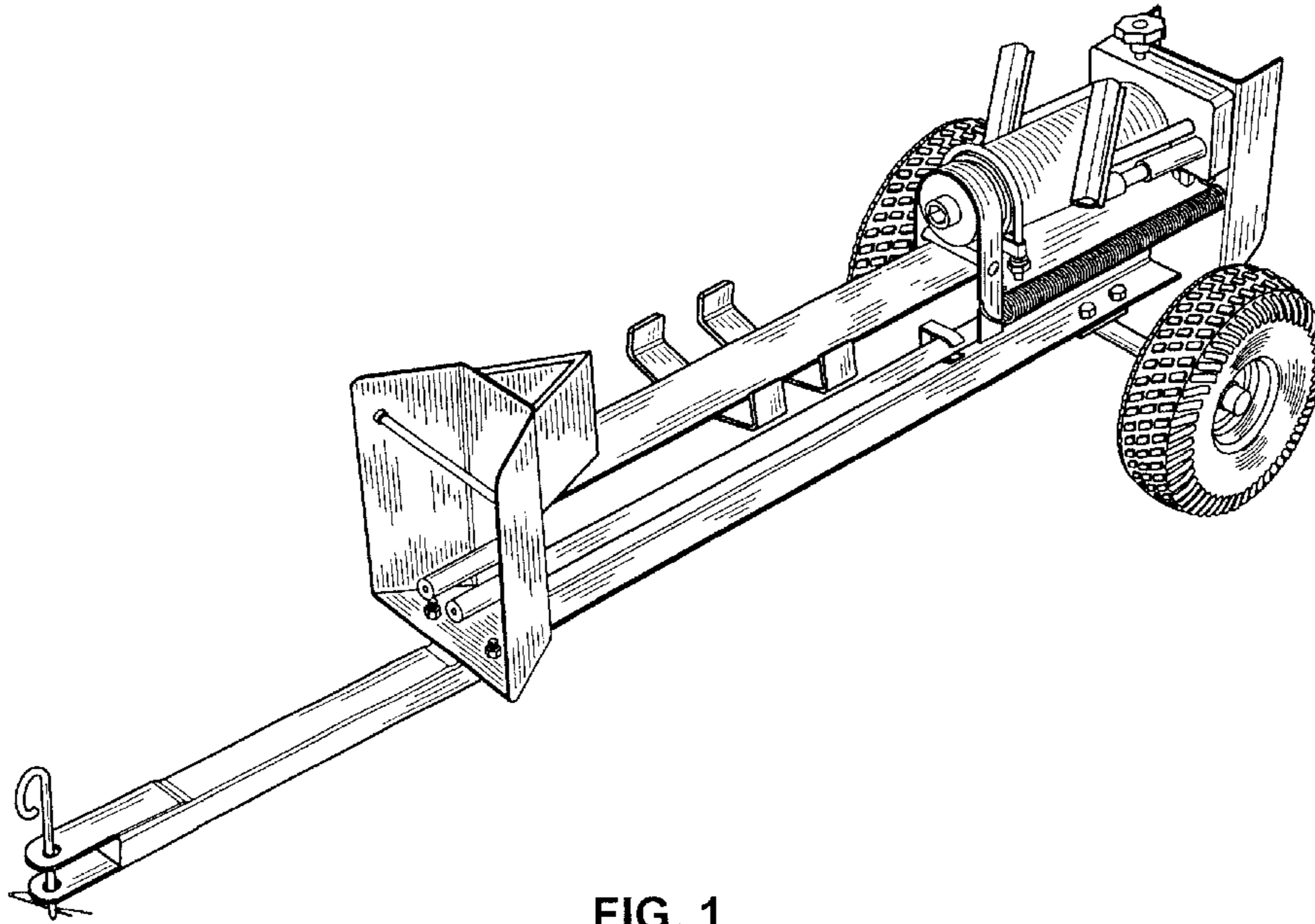

FIG. 1

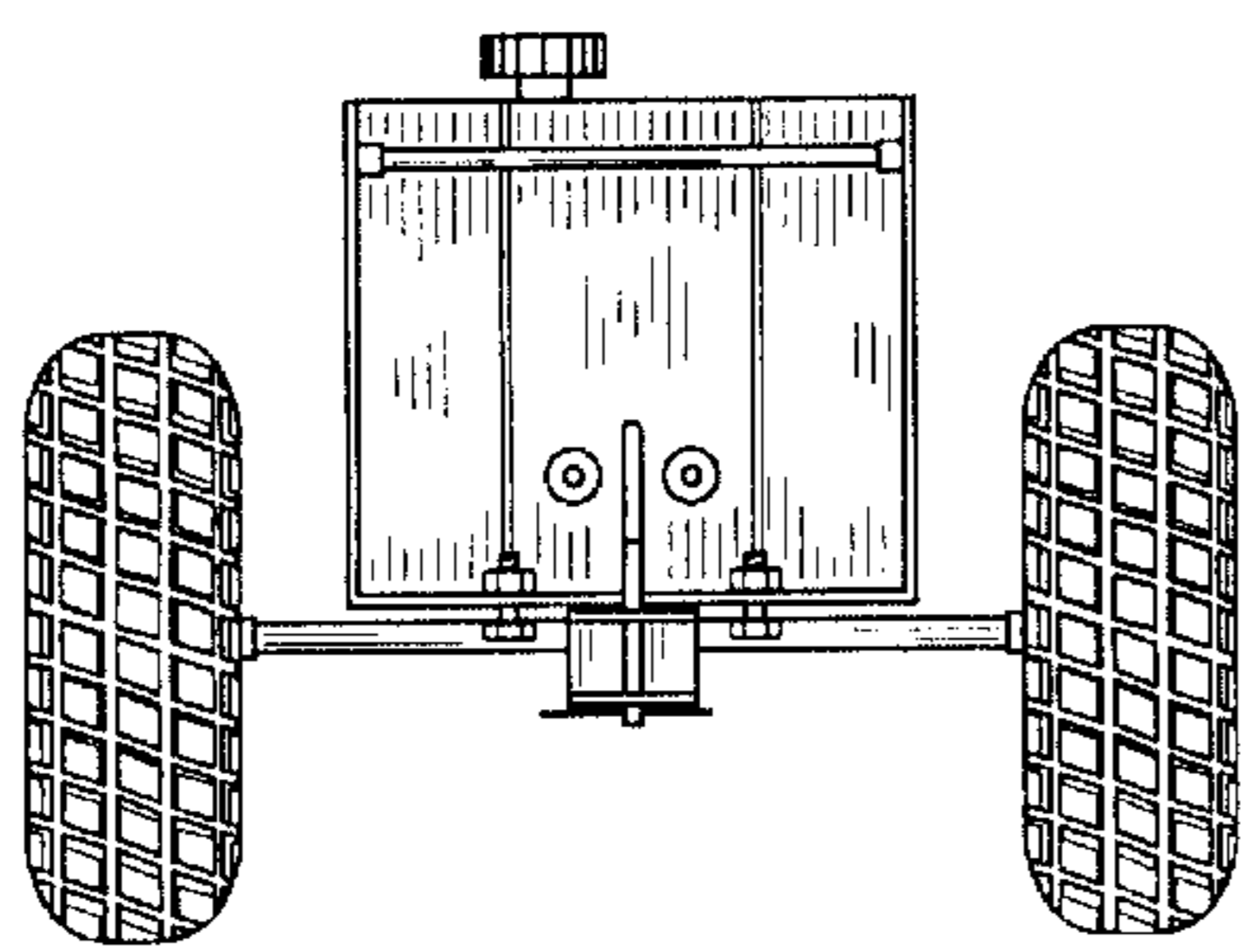

FIG. 2

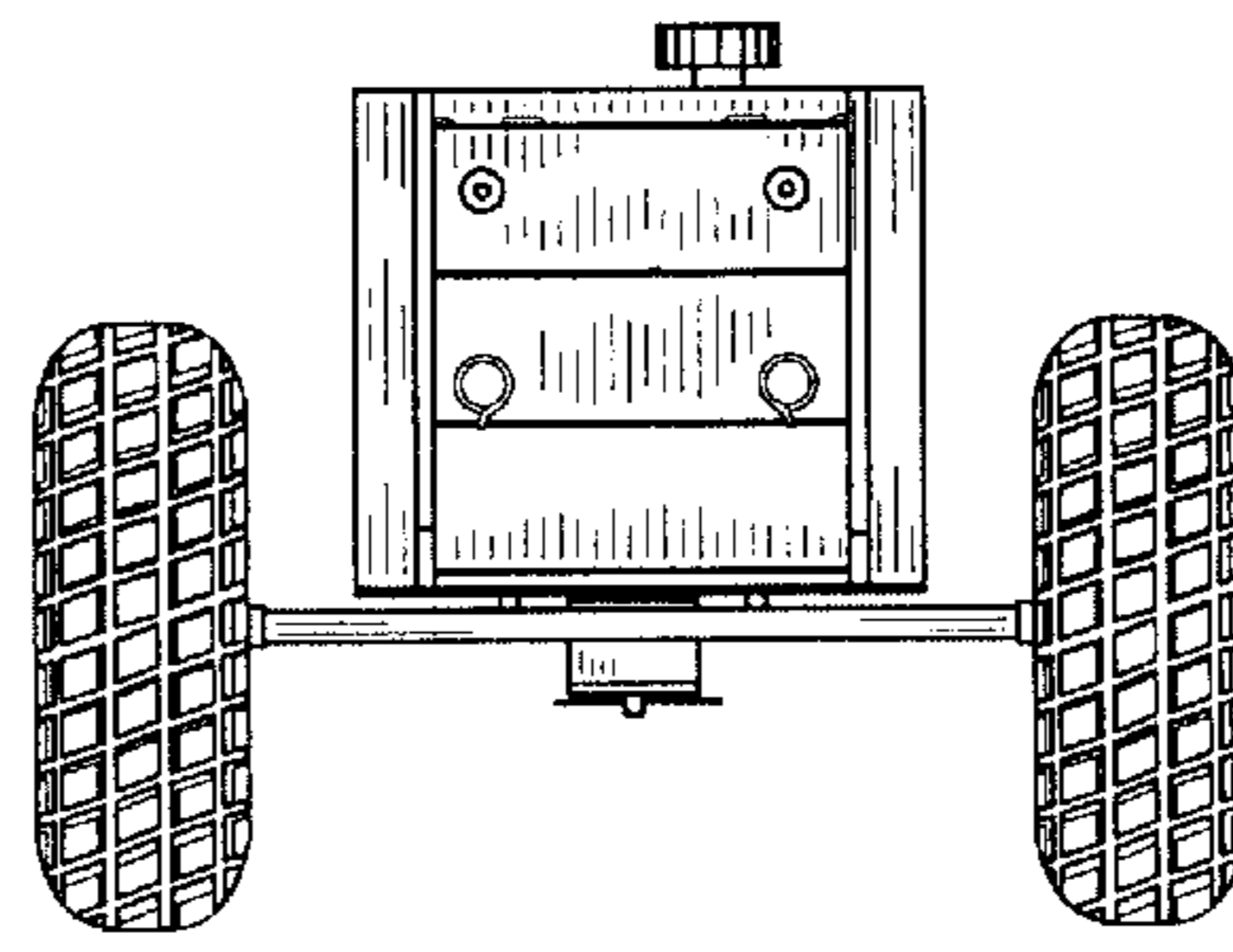

FIG. 3

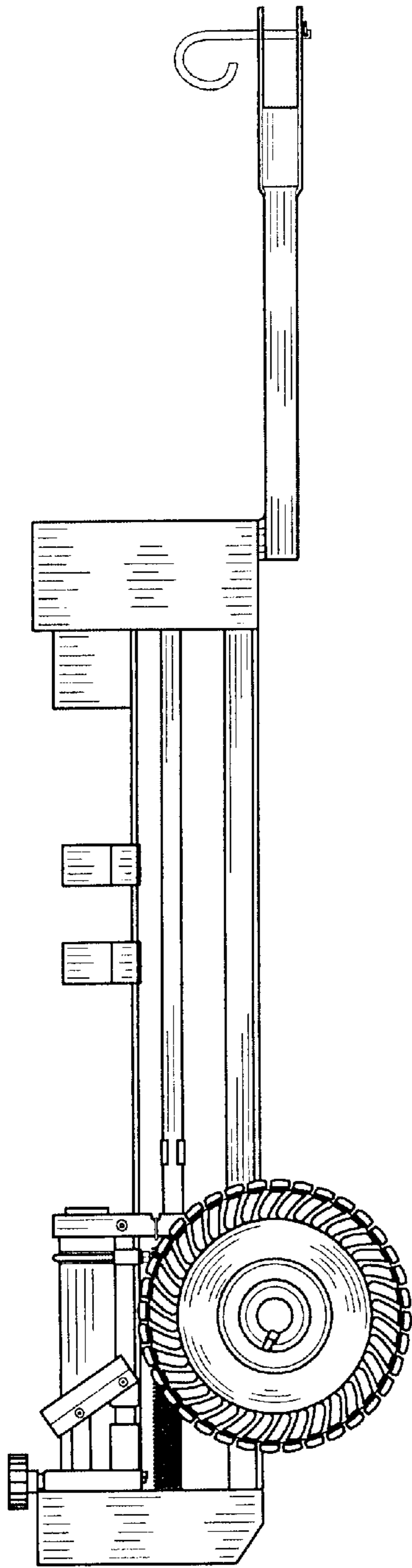

FIG. 4

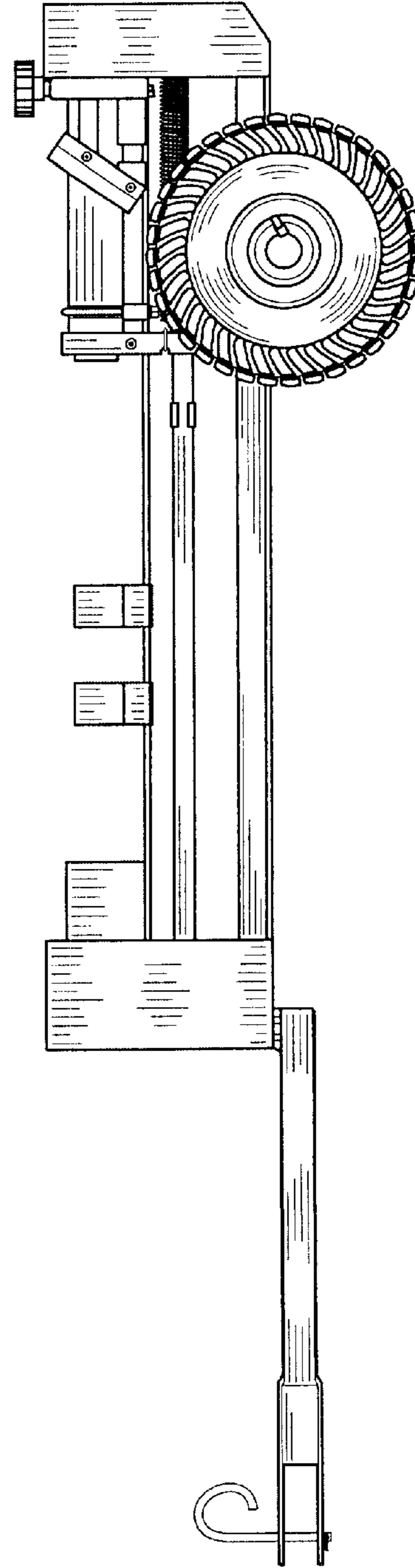

FIG. 5

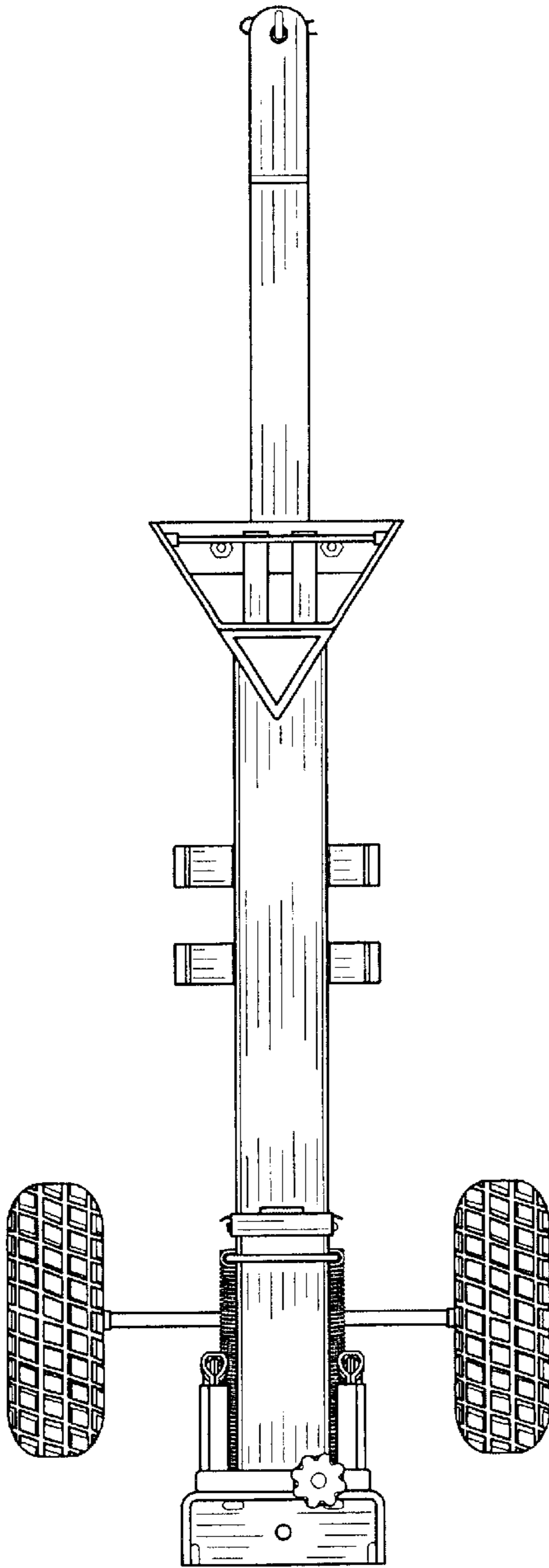

FIG. 6

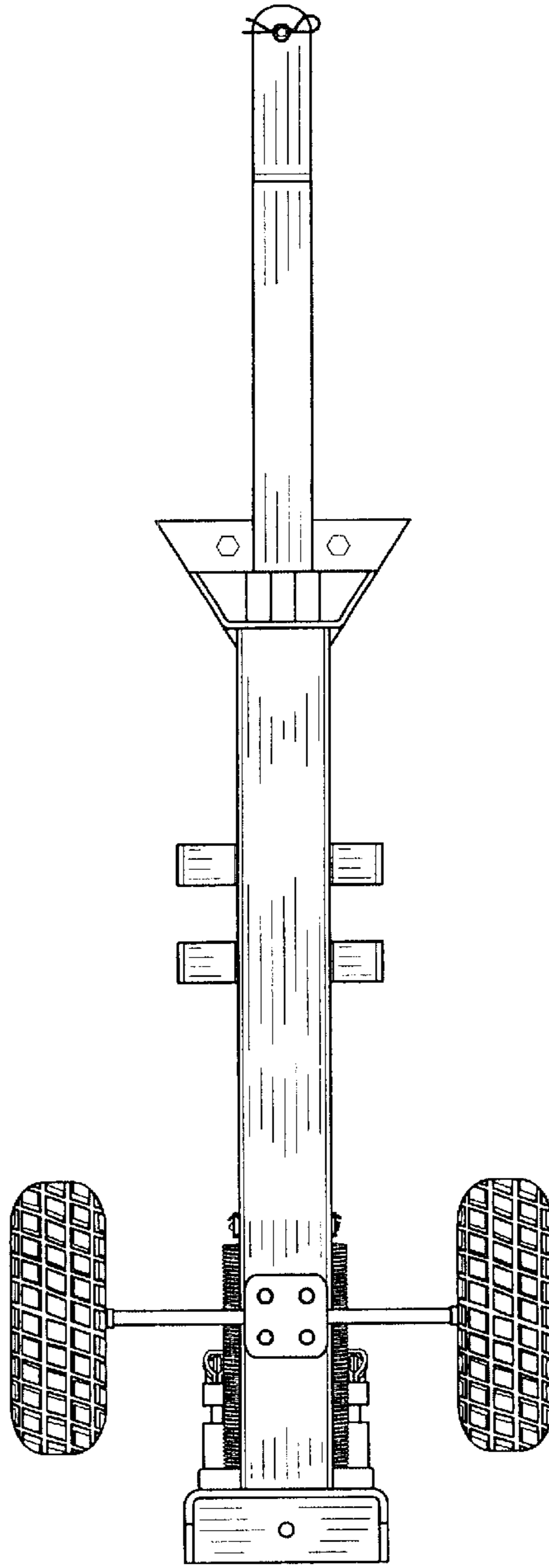

FIG. 7

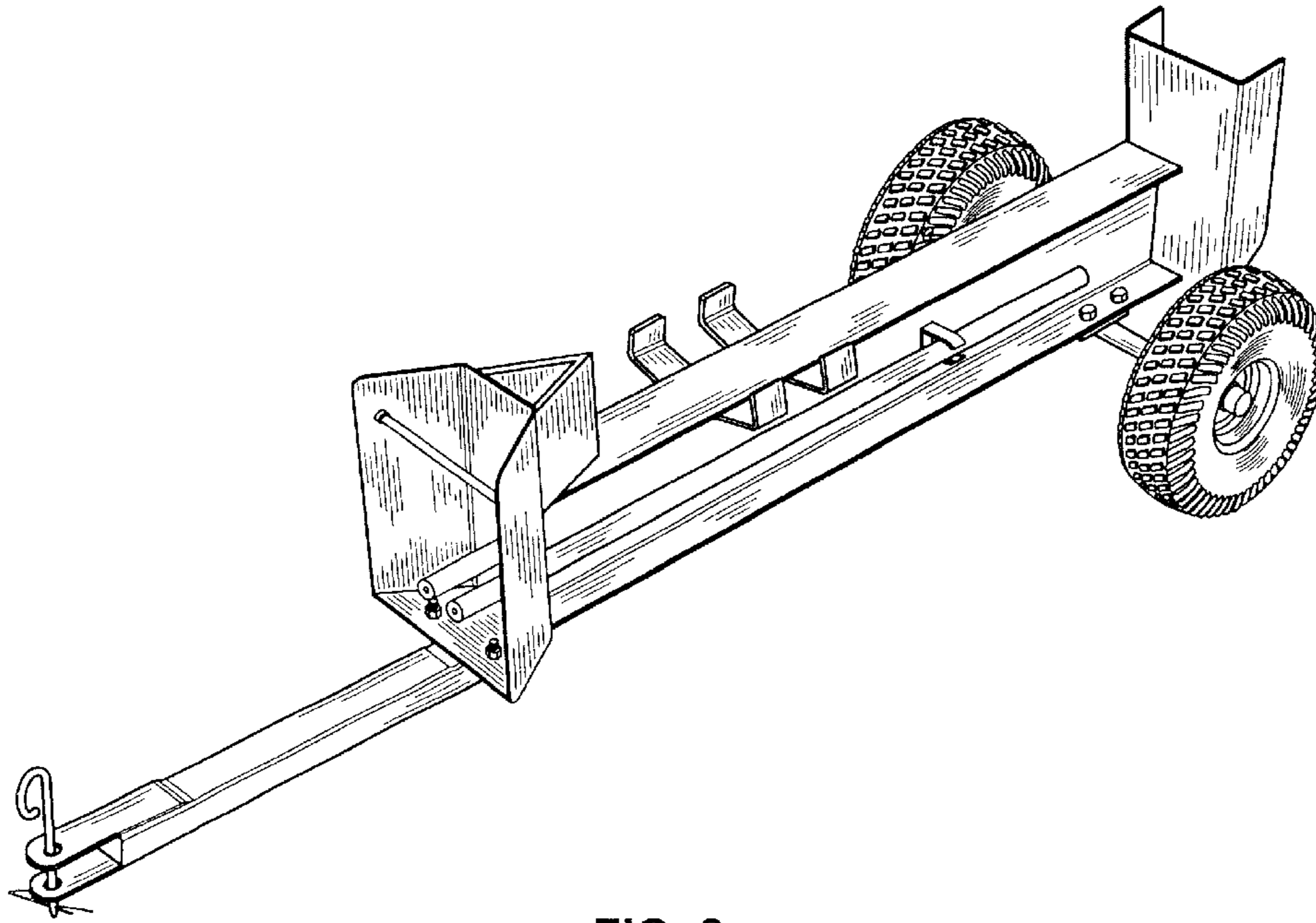

FIG. 8

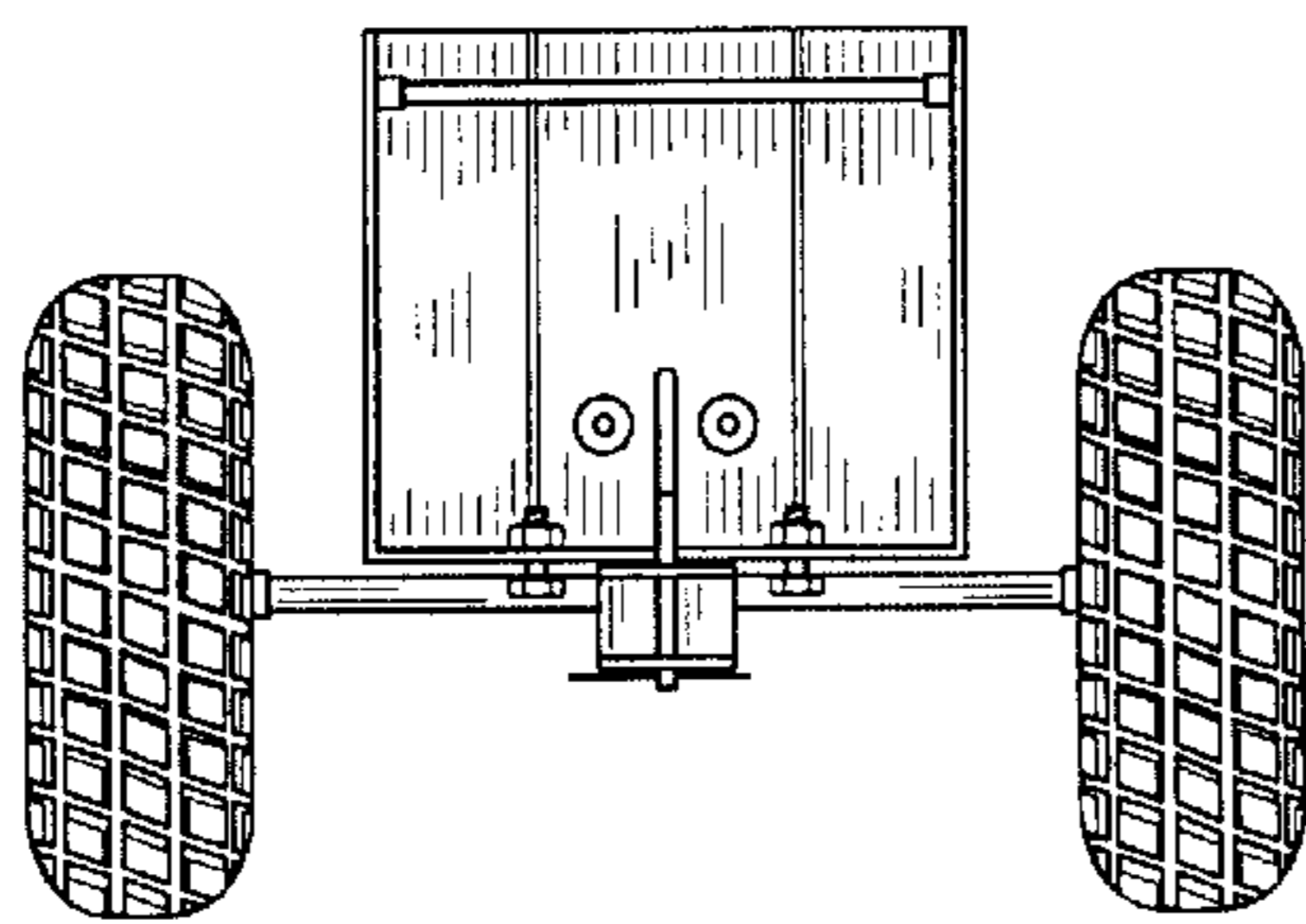

FIG. 9

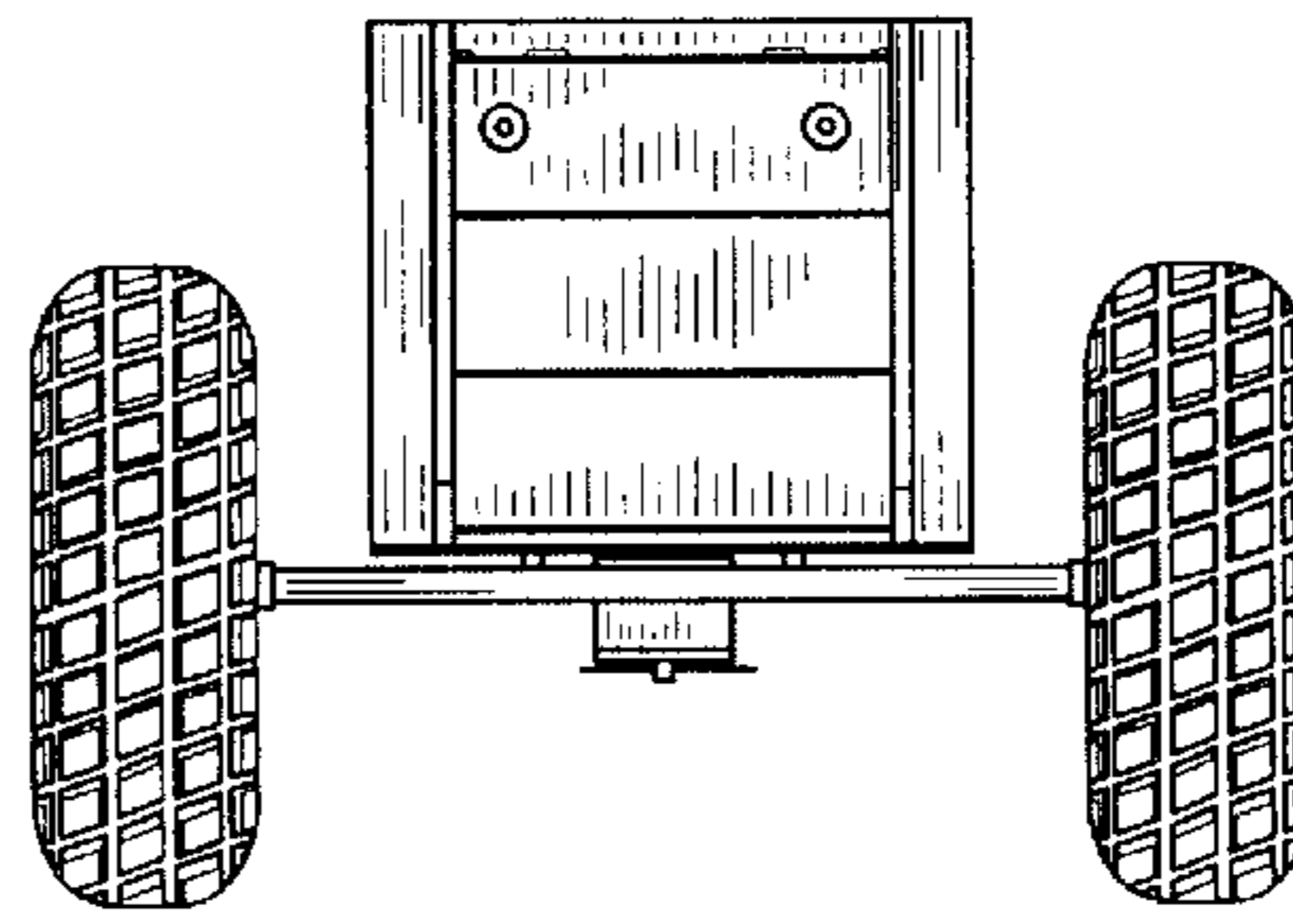

FIG. 10

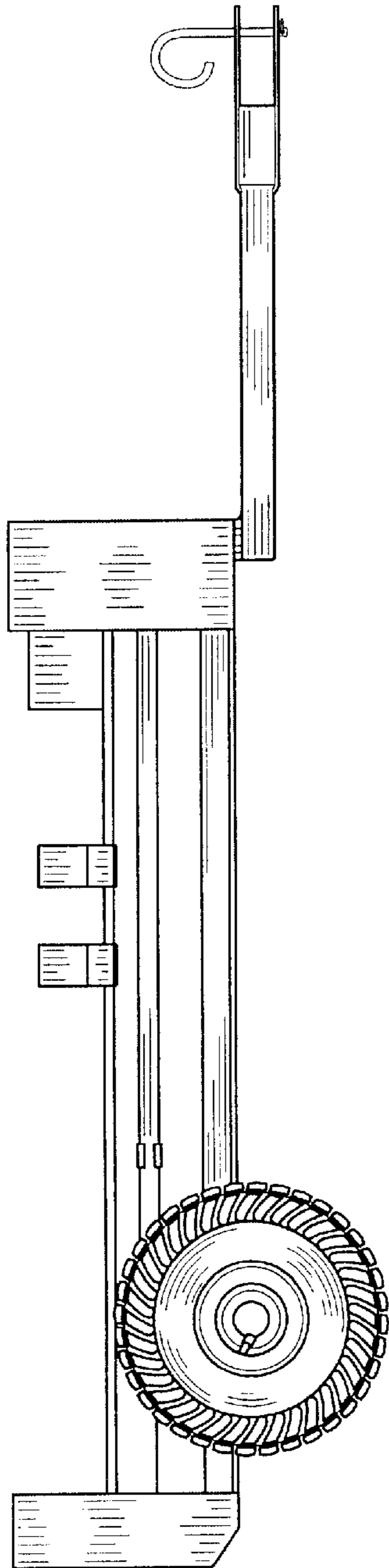

FIG. 11

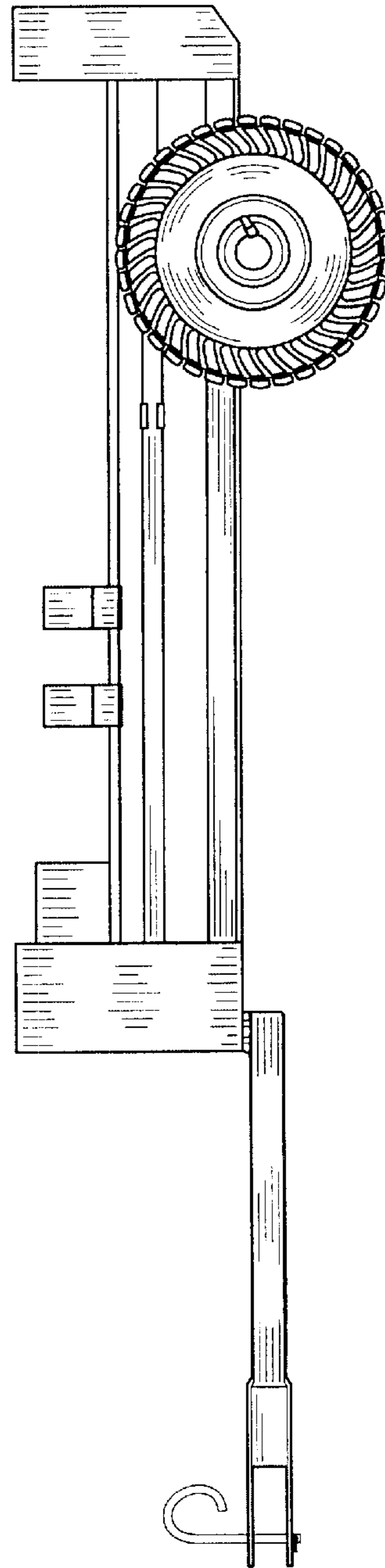

FIG. 12

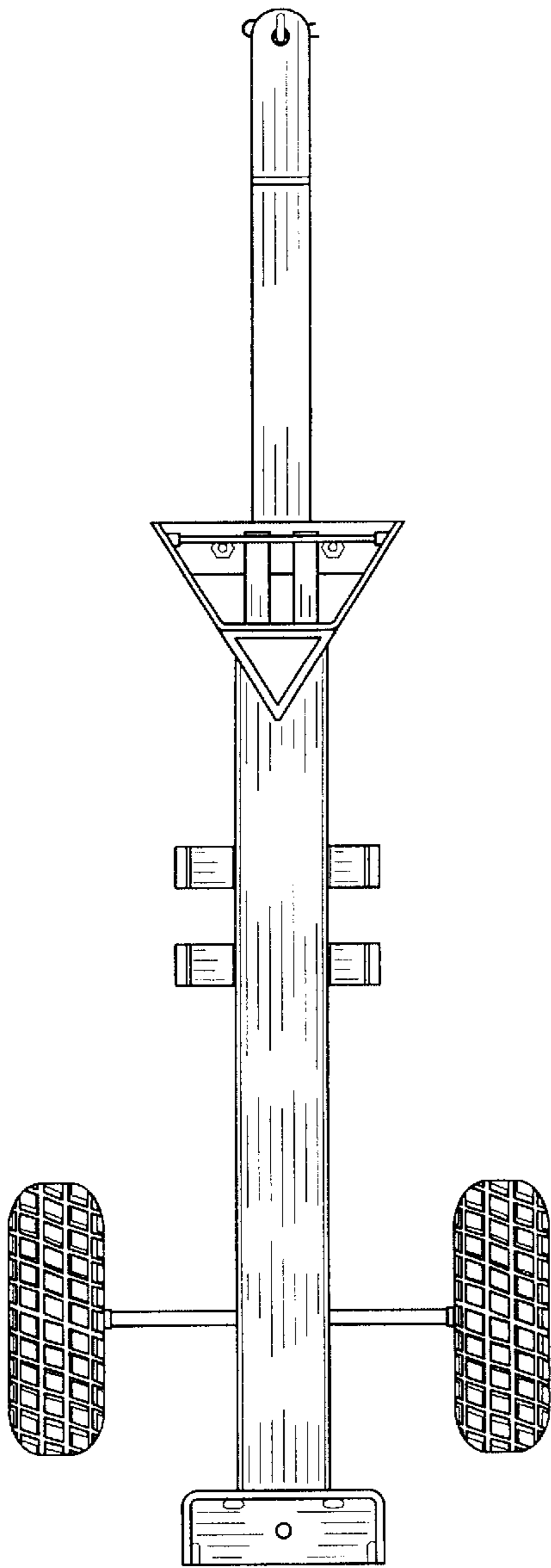

FIG. 13

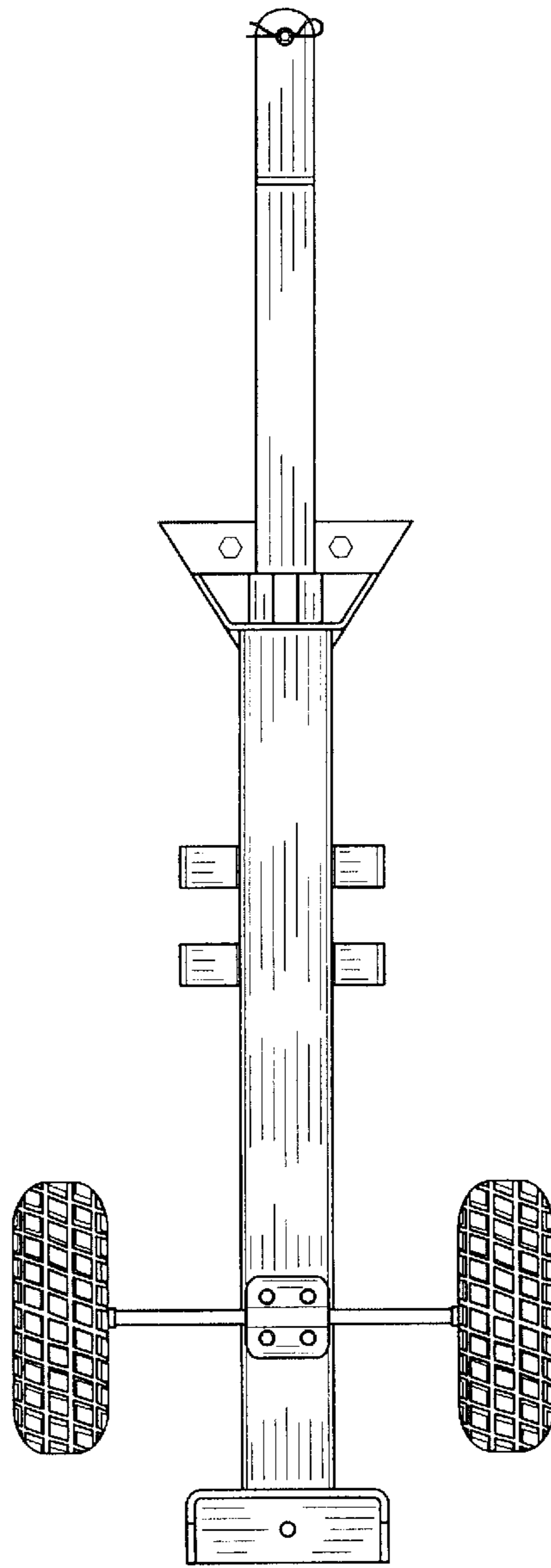

FIG. 14