

US00D509178S

(12) **United States Design Patent** (10) **Patent No.:** **US D509,178 S**  
**Panasewicz et al.** (45) **Date of Patent:** **\*\* Sep. 6, 2005**

(54) **TRUCK SHELVING SYSTEM**  
 (75) Inventors: **Dale A. Panasewicz**, Strongsville, OH (US); **Dennis M. Futo**, Strongsville, OH (US)  
 (73) Assignee: **America's Body Company**, Oakwood Village, OH (US)  
 (\*\*) Term: **14 Years**

D426,728 S \* 6/2000 Lara ..... D6/479  
 D429,095 S \* 8/2000 Grosfillex ..... D6/479  
 6,189,945 B1 2/2001 Rockett  
 6,203,087 B1 \* 3/2001 Lance et al. .... 296/37.6  
 6,386,412 B1 \* 5/2002 Konechne ..... 224/543  
 6,422,629 B2 7/2002 Lance et al.  
 6,561,601 B1 5/2003 Maffeo  
 6,641,236 B2 11/2003 Grudzien  
 6,644,712 B1 \* 11/2003 Rafi-Zadeh ..... 296/37.6  
 D485,227 S \* 1/2004 Graham ..... D12/426  
 D498,617 S \* 11/2004 Murphy et al. .... D6/479  
 6,824,184 B2 \* 11/2004 Leitner et al. .... 296/37.6

(21) Appl. No.: **29/203,150**  
 (22) Filed: **Apr. 9, 2004**

\* cited by examiner

(51) **LOC (8) Cl.** ..... **12-16**  
 (52) **U.S. Cl.** ..... **D12/425; D6/479**  
 (58) **Field of Search** ..... D12/415, 414.1, D12/414, 406, 423-425; 312/293, 311, 216; 224/275, 543, 403; D6/474, 477, 478-479, 436, 432, 414, 465, 514; 296/37.6

*Primary Examiner*—Stacia Cadmus  
 (74) *Attorney, Agent, or Firm*—Fay, Sharpe, Fagan, Minnich & McKee, LLP

(57) **CLAIM**

The ornamental design for an truck shelving system, as shown and described.

(56) **References Cited**  
**U.S. PATENT DOCUMENTS**

**DESCRIPTION**

4,191,436 A 3/1980 Cherry  
 5,398,987 A 3/1995 Sturgis  
 5,498,048 A 3/1996 Shelby, Jr.  
 5,590,939 A 1/1997 Piontek  
 5,743,584 A 4/1998 Lance et al.  
 6,007,129 A \* 12/1999 Kearney, Jr. .... 296/37.6  
 D420,970 S \* 2/2000 Sacco et al. .... D12/415  
 6,050,660 A 4/2000 Gurley  
 D426,512 S \* 6/2000 Ciuba ..... D12/425

FIG. 1 is a perspective view of a truck shelving system, showing our new design;  
 FIG. 2 is a front view thereof;  
 FIG. 3 is a right side view thereof, it being understood that the left side is a mirror image thereof;  
 FIG. 4 is a rear view thereof;  
 FIG. 5 is a top view thereof; and,  
 FIG. 6 is a bottom view thereof.

**1 Claim, 5 Drawing Sheets**

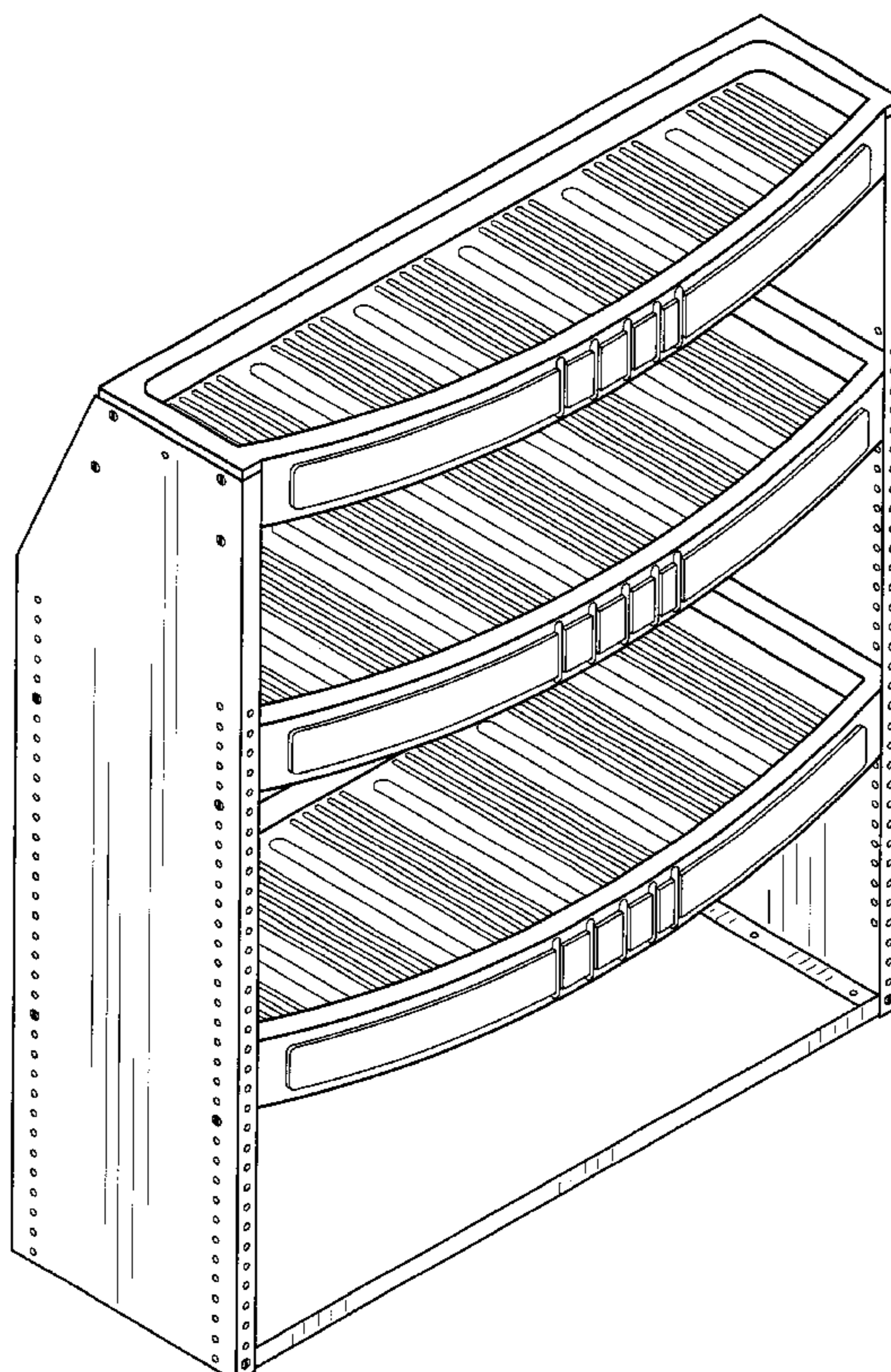

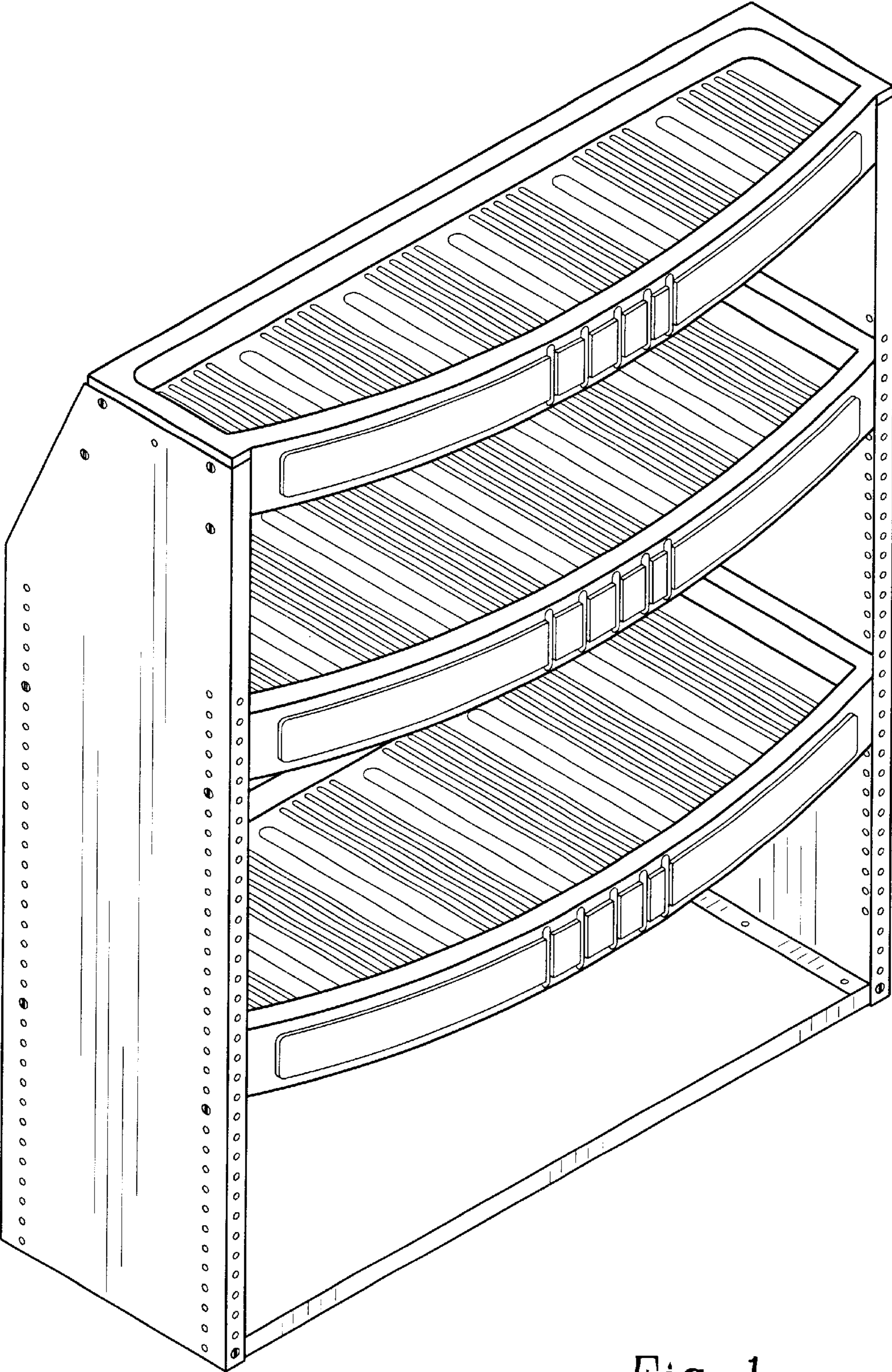

Fig. 1

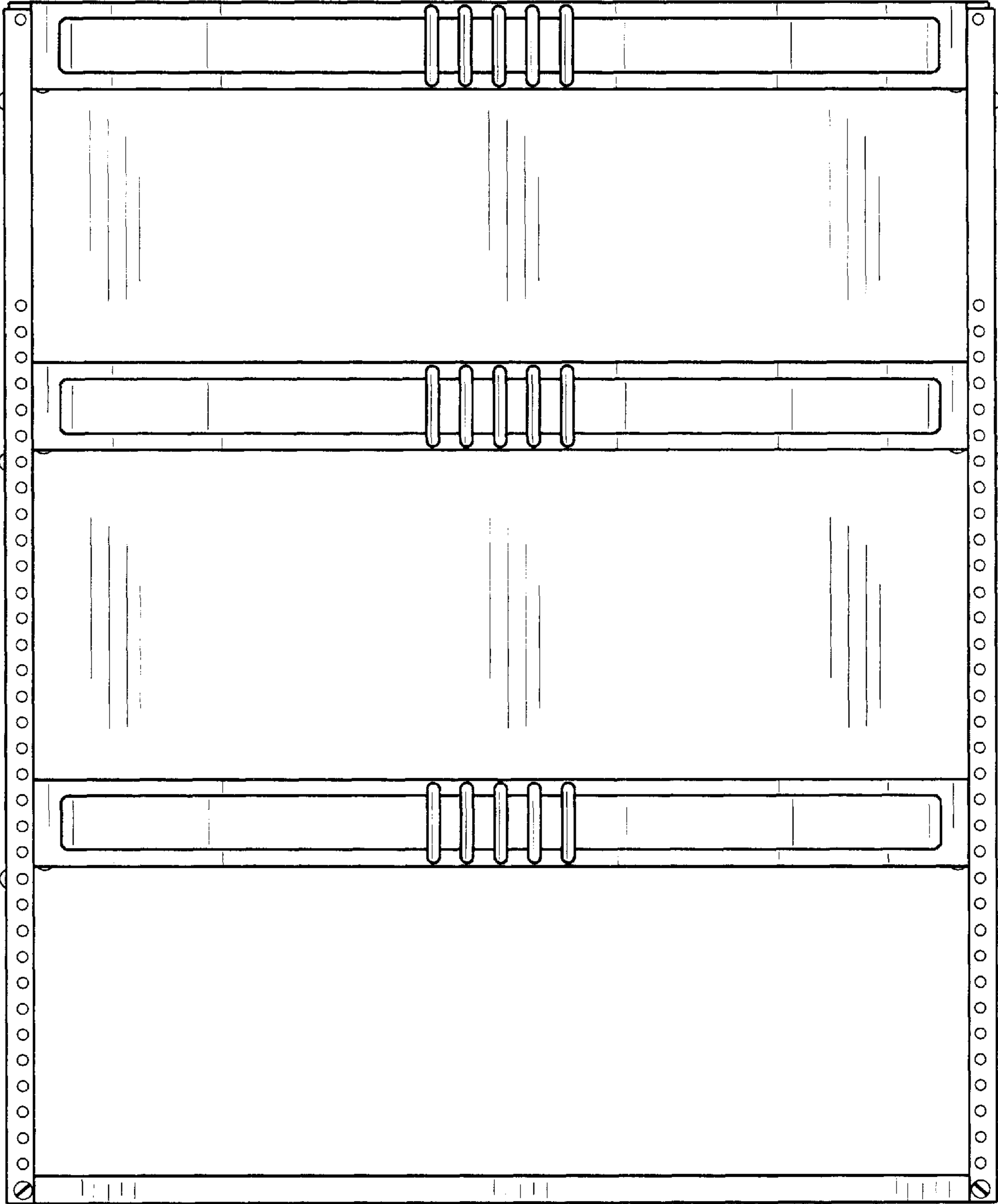
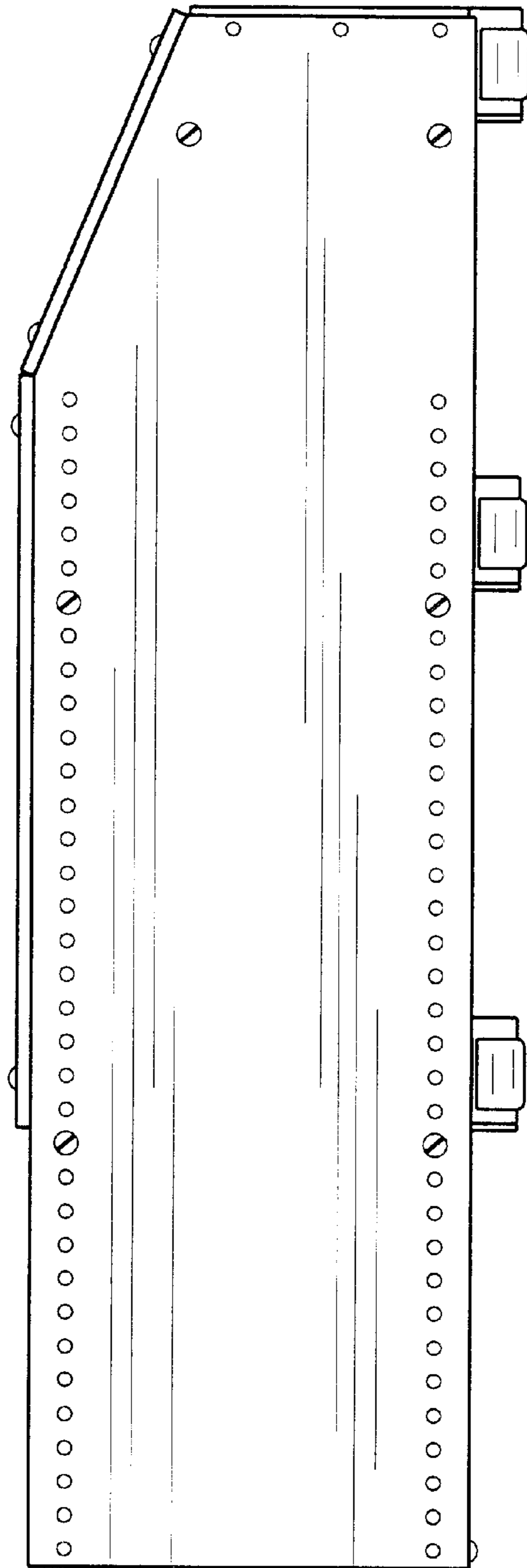
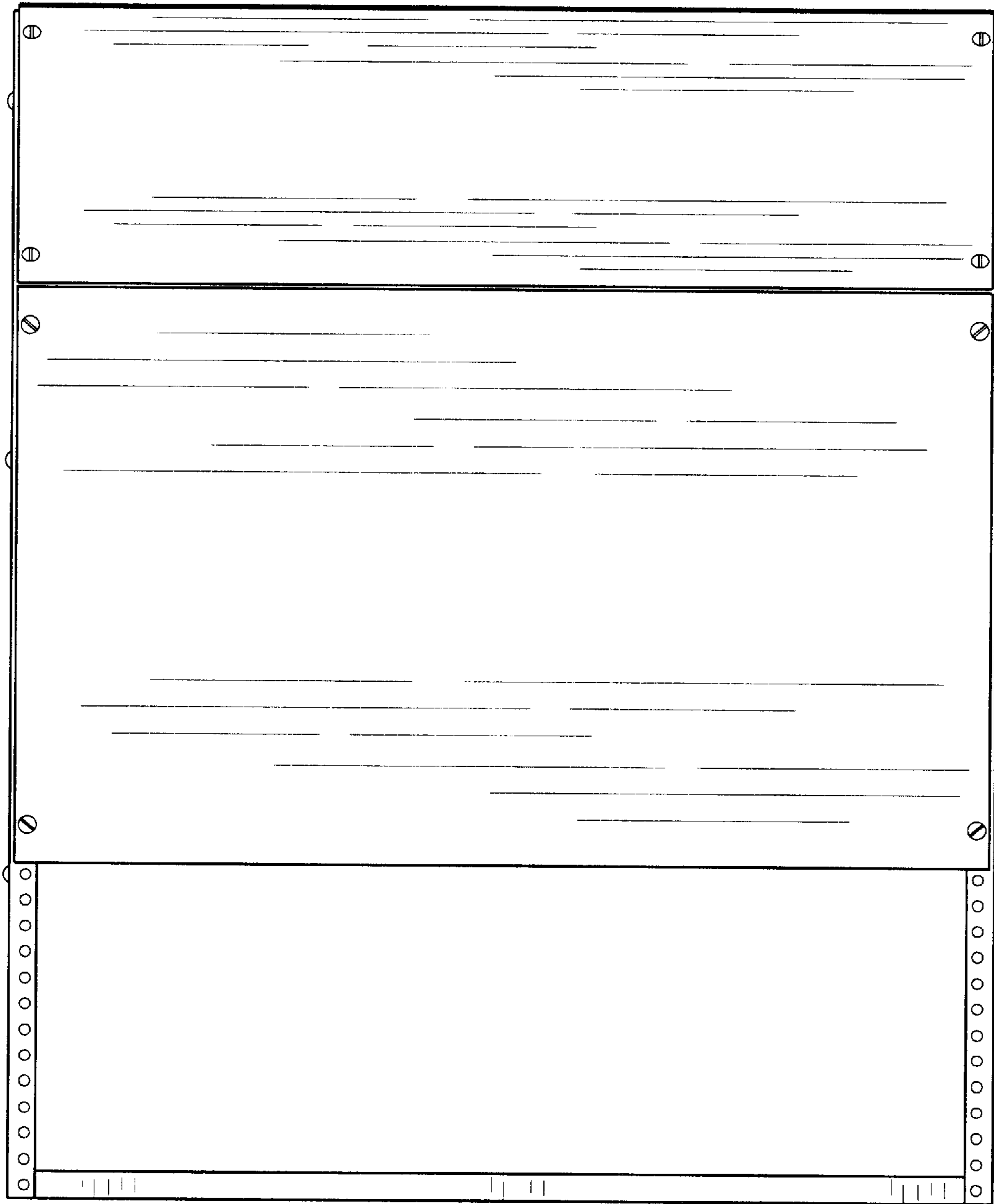

Fig. 2



*Fig. 3*



*Fig. 4*

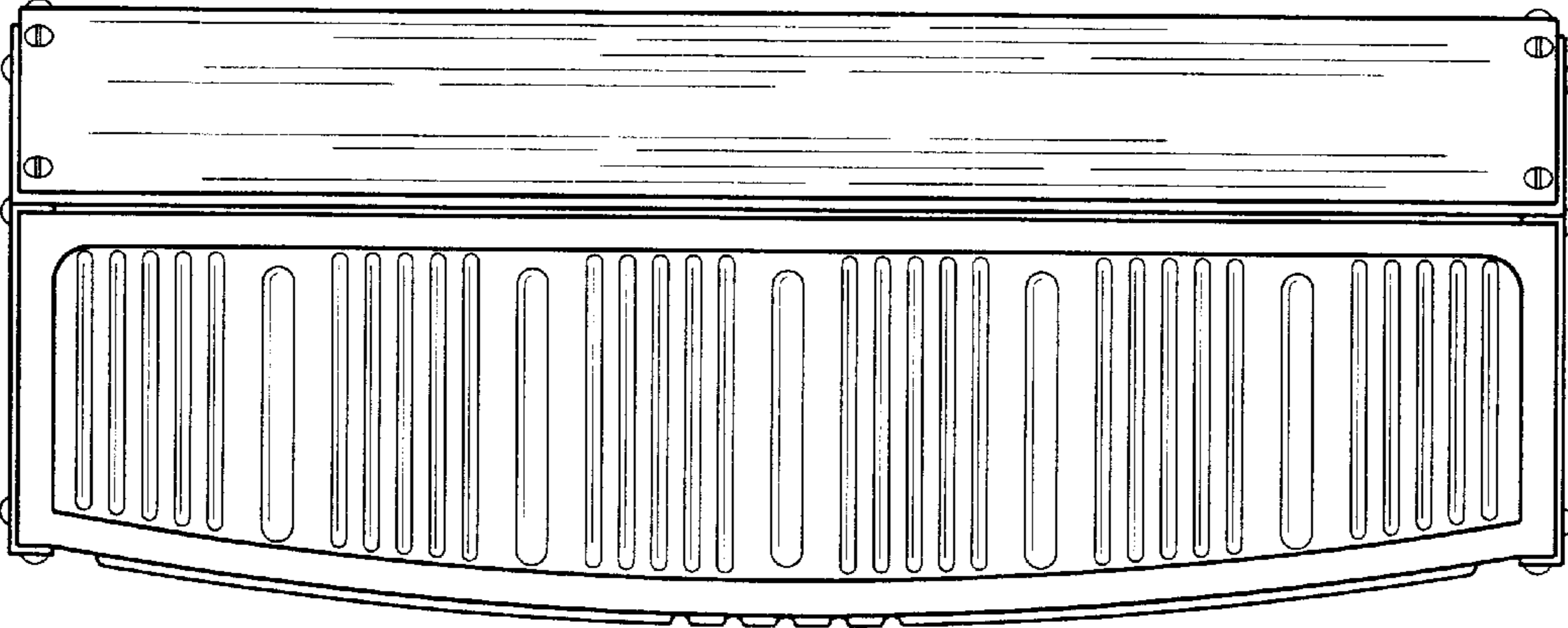

*Fig. 5*

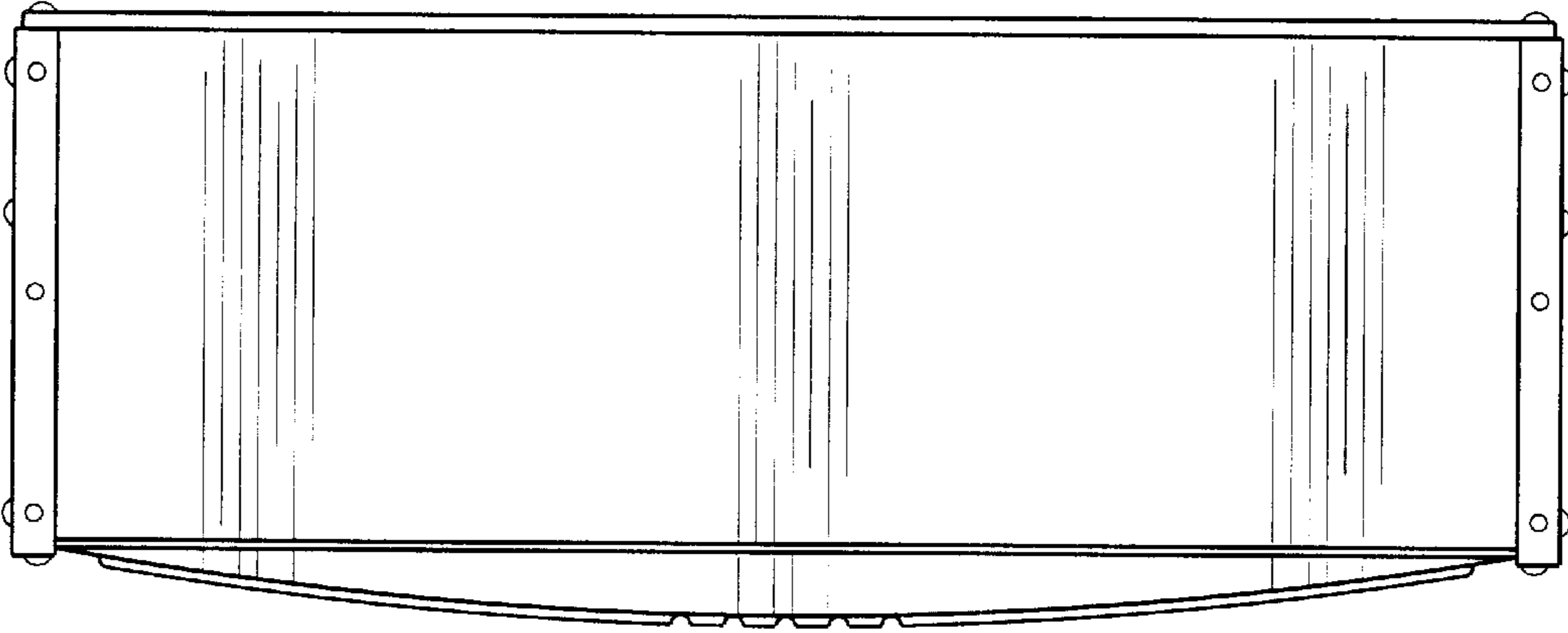

*Fig. 6*