

US00D508698S

(12) **United States Design Patent**  
**Mabbutt**

(10) **Patent No.:** **US D508,698 S**

(45) **Date of Patent:** **\*\* Aug. 23, 2005**

(54) **RACE CAR MOUSE PAD**

(76) **Inventor:** **David Liang Mabbutt**, 3700 22nd St.,  
Apt. B, San Francisco, CA (US) 94114

(\*\*) **Term:** **14 Years**

(21) **Appl. No.:** **29/192,493**

(22) **Filed:** **Oct. 25, 2003**

(51) **LOC (8) Cl.** ..... **14-02**

(52) **U.S. Cl.** ..... **D14/458**

(58) **Field of Search** ..... D14/458, 460-461,  
D14/455-457; D19/86, 92, 95; 248/118,  
118.1, 118.5, 118.3, 451, 917-924; D21/339,  
334, 549, 320; D20/23, 11

(56) **References Cited**

**U.S. PATENT DOCUMENTS**

D90,923 S	*	10/1933	Moloney	.....	D21/320
D382,551 S		8/1997	Tran		
D388,414 S		12/1997	Carlson		
D399,833 S		10/1998	Barrette		
D419,196 S	*	1/2000	Lewis et al.	.....	D20/35
D425,048 S		5/2000	Lin		
D452,248 S	*	12/2001	Li	.....	D14/458
D462,970 S	*	9/2002	Tonizzo et al.	.....	D14/458
D471,915 S	*	3/2003	Joss et al.	.....	D14/458
D476,014 S		6/2003	Mabbutt		

D476,338 S	6/2003	Mabbutt
D476,661 S	7/2003	Mabbutt
D476,993 S	7/2003	Mabbutt

\* cited by examiner

*Primary Examiner*—Pamela Burgess

(74) *Attorney, Agent, or Firm*—Edwin A. Skoch

(57) **CLAIM**

The ornamental design for a race car mouse pad, as shown and described.

**DESCRIPTION**

A mouse pad that has the appearance of a racecar, including ornamental rear spoiler, to be used for ornamentation and as a game.

FIG. 1 is a top perspective view of a racecar mouse pad, showing my new design.

FIG. 2 is a top plan view thereof.

FIG. 3 is a bottom plan view thereof.

FIG. 4 is a right side elevation view thereof.

FIG. 5 is a front elevation view thereof; and,

FIG. 6 is a rear elevation view thereof.

The broken line illustration of the computer mouse and logos shown in the views are for illustrative purpose only, and form no part of the claimed design.

**1 Claim, 2 Drawing Sheets**

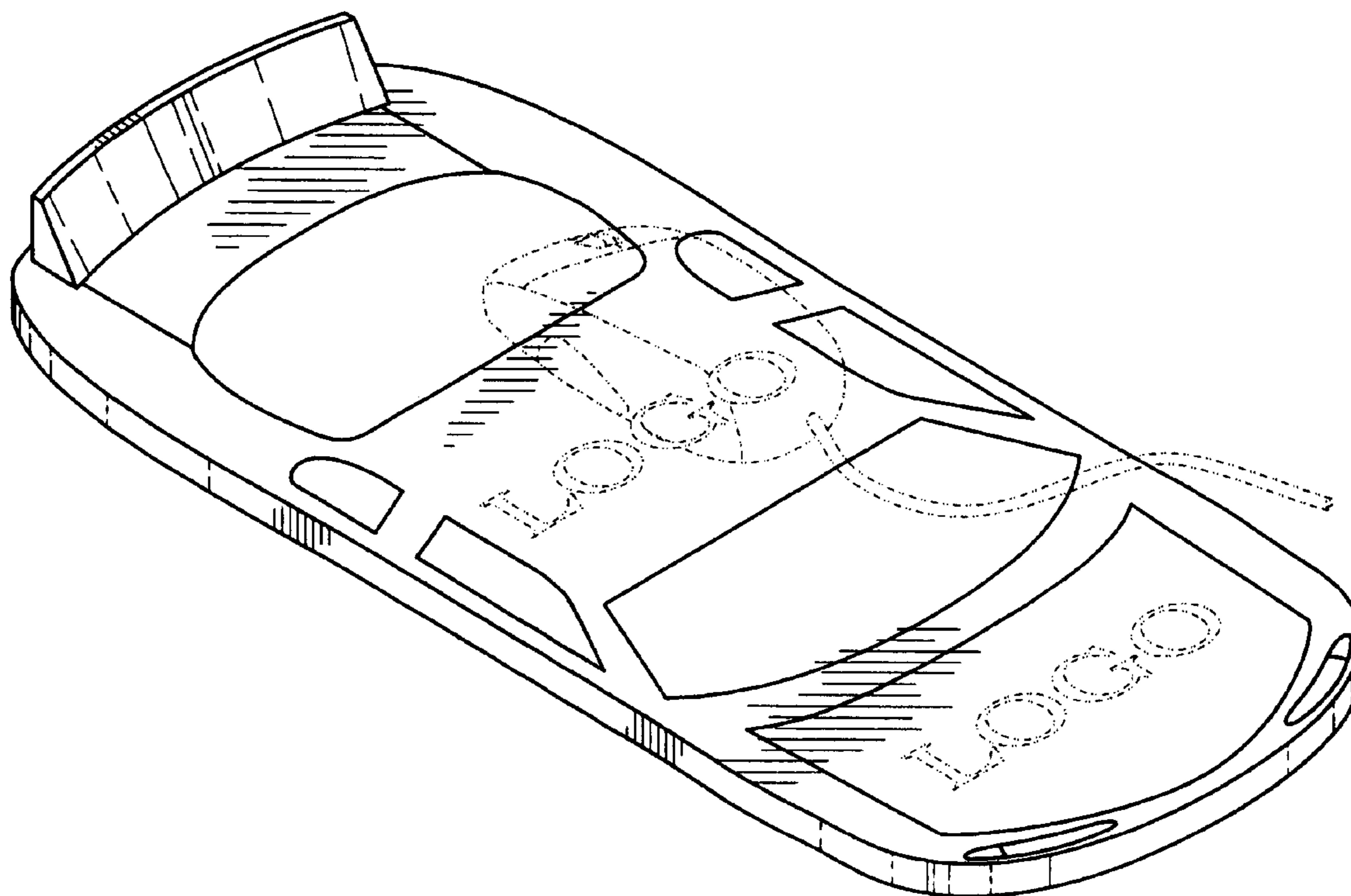

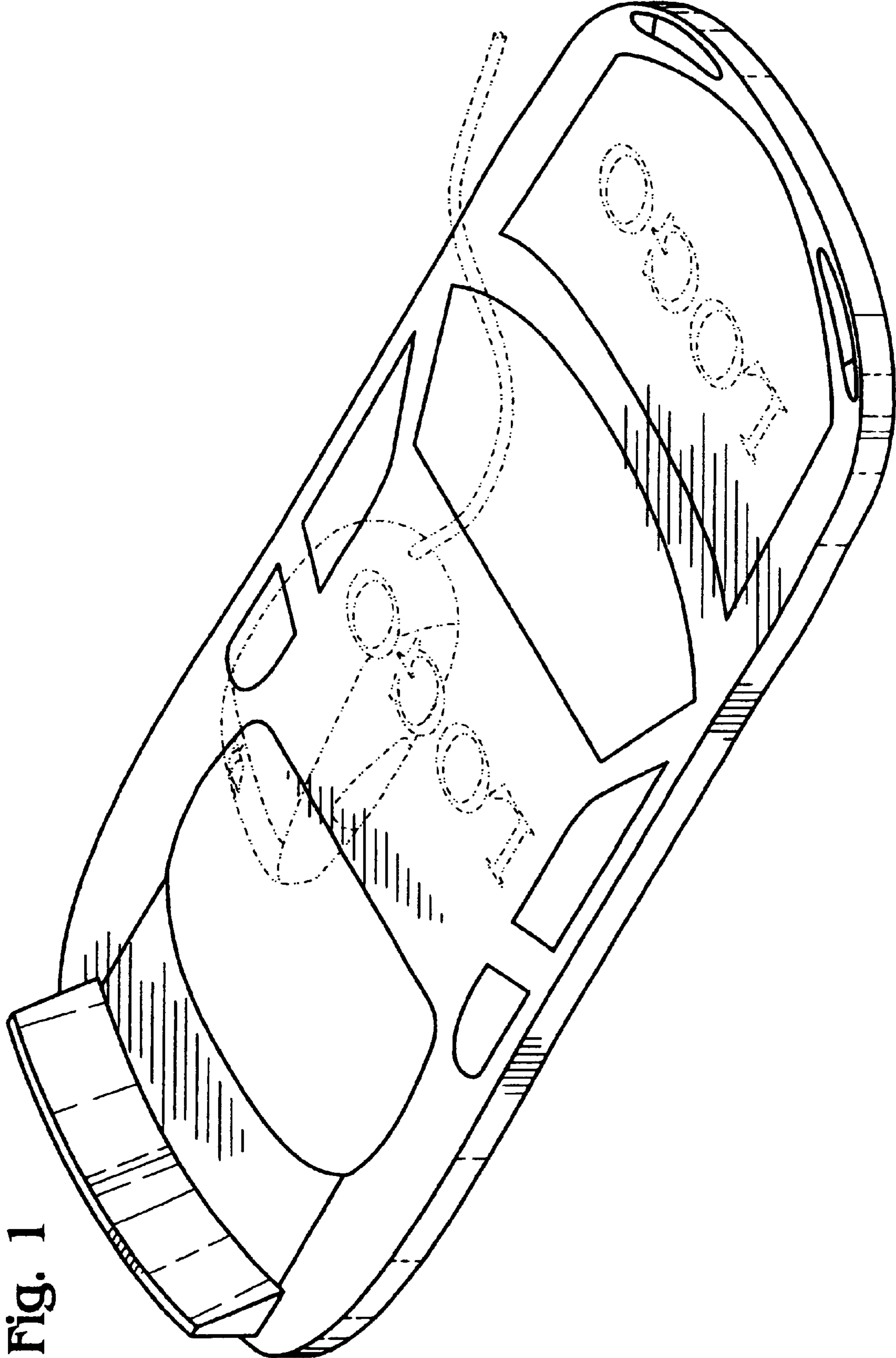

Fig. 1

Fig. 2

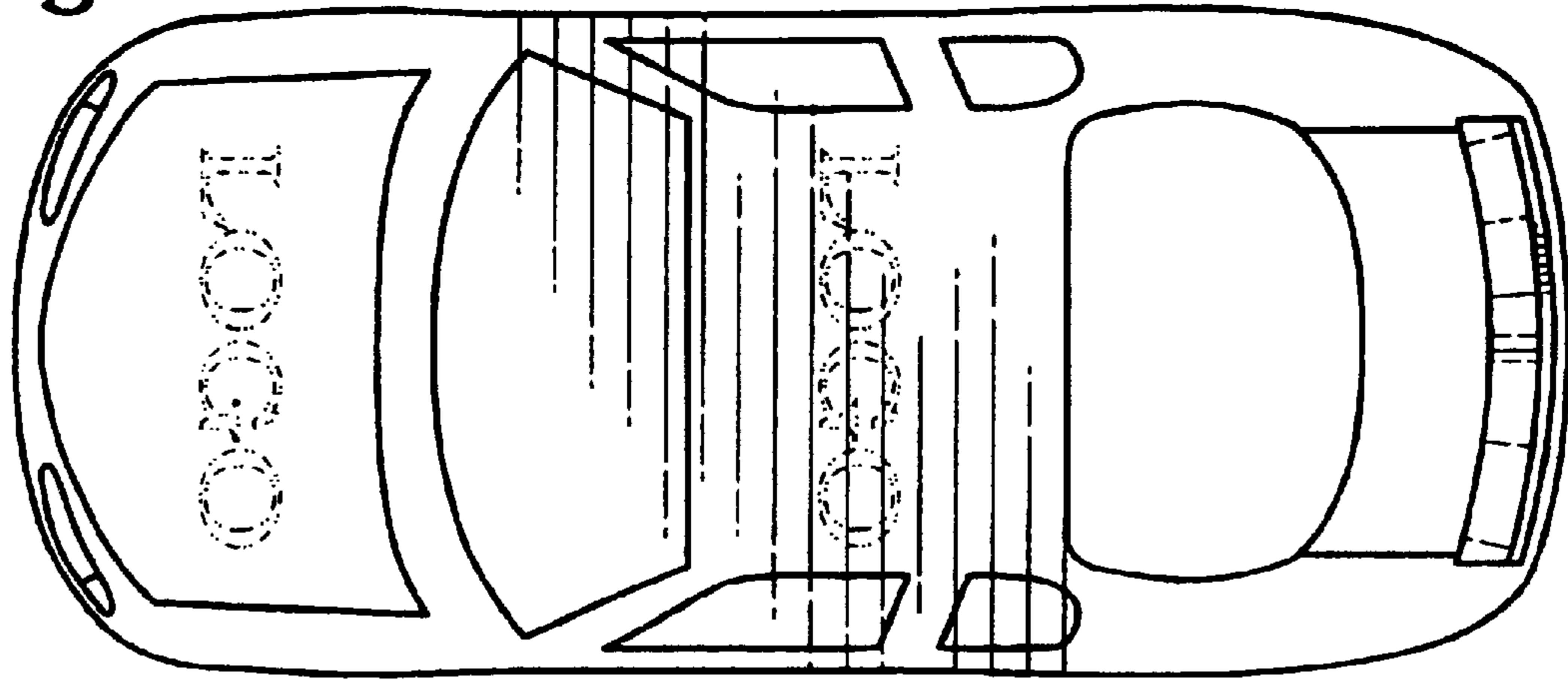

Fig. 3

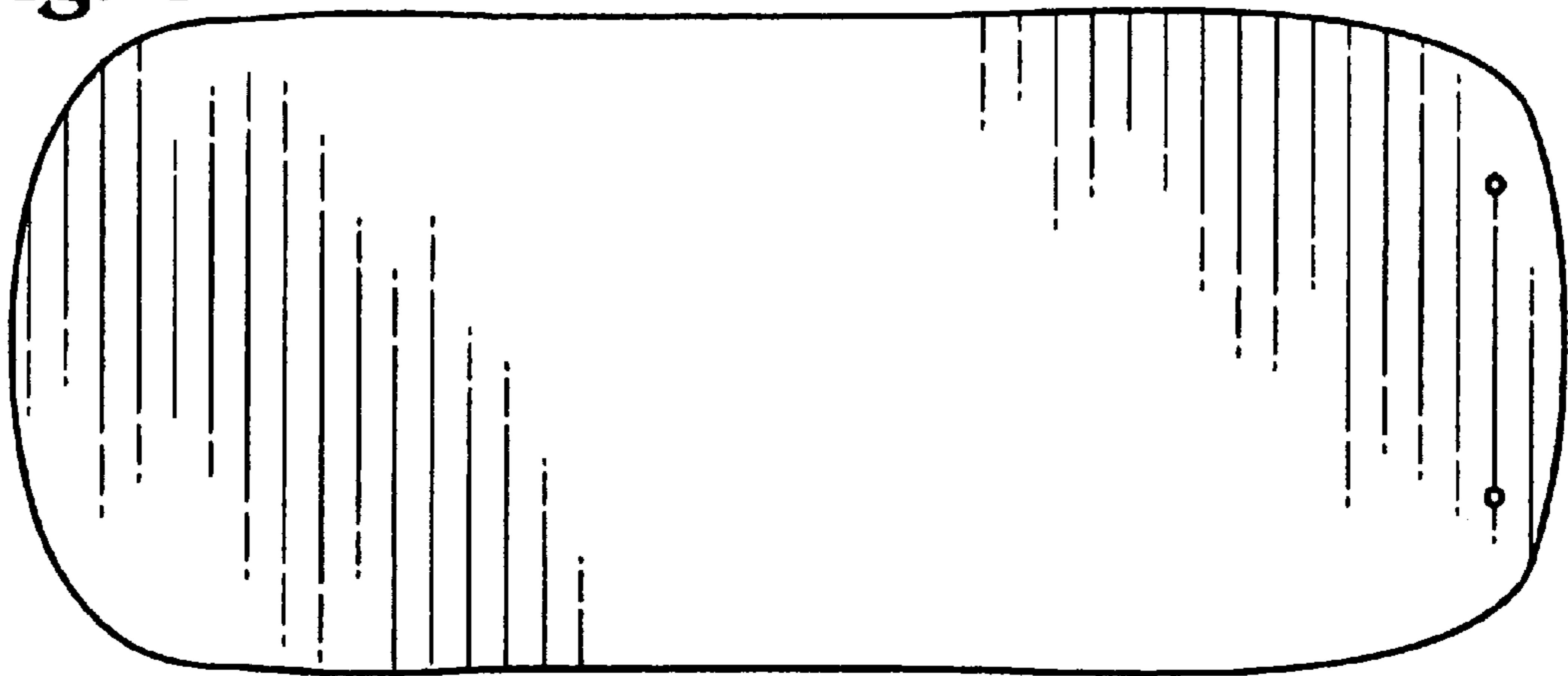

Fig. 4



Fig. 5



Fig. 6

