

US00D508457S

(12) **United States Design Patent** (10) **Patent No.:** **US D508,457 S**  
**Green** (45) **Date of Patent:** **\*\* Aug. 16, 2005**

- (54) **TIRE LUG**
- (75) Inventor: **Michael L. Green**, St. Louis, MO (US)
- (73) Assignee: **Tire Mart, Inc.**, St. Louis, MO (US)
- (\*\*) Term: **14 Years**
- (21) Appl. No.: **29/191,681**
- (22) Filed: **Oct. 10, 2003**
- (51) **LOC (8) Cl.** ..... **12-15**
- (52) **U.S. Cl.** ..... **D12/604**
- (58) **Field of Search** ..... D12/507, 512,  
D12/513, 536, 539, 574, 544, 545, 552,  
571, 579, 580, 587, 602, 604; 152/209.1,  
209.12, 902

(56) **References Cited**

**U.S. PATENT DOCUMENTS**

D162,410 S *	3/1951	Hawkinson	.....	D12/574
D247,485 S *	3/1978	Lamb	.....	D12/580
D256,226 S *	8/1980	Buck et al.	.....	D12/574
D261,495 S *	10/1981	Yurkovich	.....	D12/579
D409,122 S *	5/1999	Kemp et al.	.....	D12/602
D418,091 S *	12/1999	Slutz	.....	D12/580
6,189,586 B1	2/2001	Guidry		
D460,404 S *	7/2002	Janjareh et al.	.....	D12/580
6,736,175 B2 *	5/2004	Carra et al.	.....	152/209.18
D492,643 S *	7/2004	Robert	.....	D12/579

**OTHER PUBLICATIONS**

- Michelin XD4 Tire, Michelin Commercial Light Truck Tire and Truck Tire Data Book, 2nd Edition.\*
- Discoverer Radial & LT Tire, Cooper Light Truck and SUV Radial Tires Brochure No. 860-N81-6489, May 1999, p. 3.\*
- Kelly Safari MSR Tire, 2002 Tread Design Guide, Jan. 2002, p. 90. 1/4.\*
- Mastercraft Courser Radial LT Tire, 2002 Tread Design Guide, Jan. 2002, p. 95, 1/2.\*
- FALKEN, Radial A/P, 2002 Tread Design Guide, p. 29, vol. 37, Bennett Garfield.
- GISLAVED, Nord Frost II, 2002 Tread Design Guide, p. 33, vol. 37, Bennett Garfield.

GOODYEAR, Eagle GTII, 2002 Tread Design Guide, p. 34, vol. 37, Bennett Garfield.

(Continued)

*Primary Examiner*—Robert M. Spear  
(74) *Attorney, Agent, or Firm*—Blumenfeld, Kaplan & Sandweiss, P.C.

(57) **CLAIM**

The ornamental design for a tire lug, as shown and described.

**DESCRIPTION**

FIG. 1 is a perspective view of a tire lug in accordance with my new design;  
 FIG. 2 is a top plan view thereof;  
 FIG. 3 is a side elevational view thereof, all four sides being identical;  
 FIG. 4 is a perspective view of another embodiment of my new design;  
 FIG. 5 is a top plan view thereof;  
 FIG. 6 is a front elevational view thereof, the back elevational view being identical;  
 FIG. 7 is a side elevational view thereof, the opposite side being identical;  
 FIG. 8 is a perspective view of a further embodiment of my new design;  
 FIG. 9 is a top plan view thereof;  
 FIG. 10 is a side elevational view thereof, all four sides being identical;  
 FIG. 11 is a perspective view of yet another embodiment of my new design;  
 FIG. 12 is a top plan view thereof;  
 FIG. 13 is a front elevational view thereof, the back elevational view being identical; and,  
 FIG. 14 is a side elevational view thereof, the opposite side being identical.

Throughout the drawings broken lines indicate environment, specifically the surface of tire, for purposes of illustration only, and form no part of the claimed design.

**1 Claim, 12 Drawing Sheets**

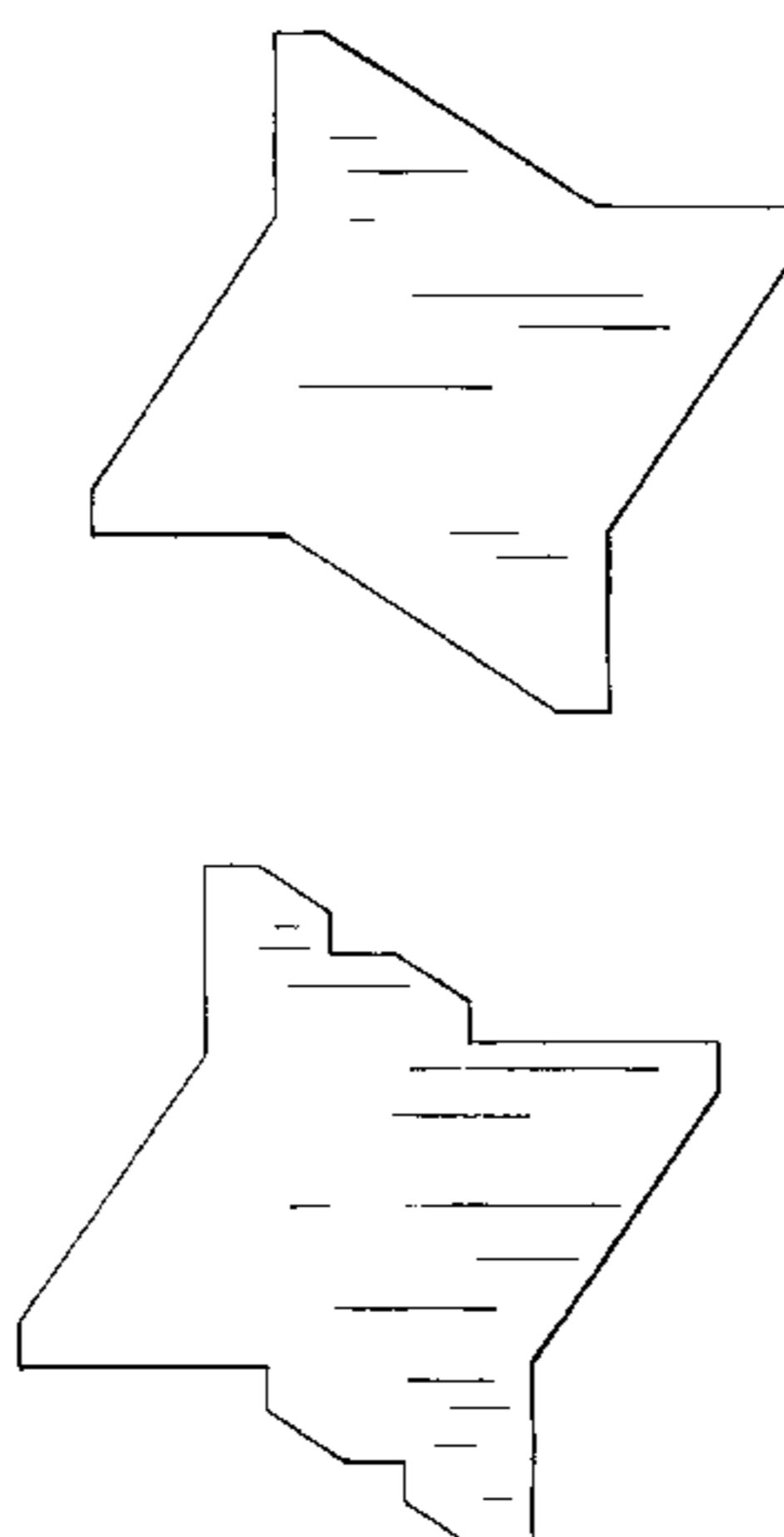

OTHER PUBLICATIONS

- KUMHO, Power Grip VI, 2002 Tread Design Guide, p. 42, vol. 37, Bennett Garfield.
- MASTERCRAFT, Courser Steel Radial, 2002 Tread Design Guide, p. 45, vol. 37, Bennett Garfield.
- MERIT, Four Season, 2002 Tread Design Guide, p. 46, vol. 37, Bennett Garfield.
- MERIT, Signet Winter Trax, 2002 Tread Design Guide, p. 47, vol. 37, Bennett Garfield.
- MICHELIN, XZ4, 2002 Tread Design Guide, p. 29, vol. 48, Bennett Garfield.
- STARFIRE, Bronco Radial APD, 2002 Tread Design Guide, p. 64, vol. 37, Bennett Garfield.
- GOODYEAR, Wrangler MT/R, 2002 Tread Design Guide, p. 86, vol. 37, Bennett Garfield.
- HANKOOK, Dynamic 4x4 Z87, 2002 Tread Design Guide, p. 88, vol. 37, Bennett Garfield.
- MERIT, All Country, 2002 Tread Design Guide, p. 96, vol. 37, Bennett Garfield.
- OHTSU, Radial A/P, 2002 Tread Design Guide, p. 102, vol. 37, Bennett Garfield.
- ROADMASTER, Roughneck A/T, 2002 Tread Design Guide, p. 104, vol. 37, Bennett Garfield.
- YOKOHAMA, Y703B, 2002 Tread Design Guide, p. 112, vol. 37, Bennett Garfield.
- DOUBLE COIN, RLB 500, 2002 Tread Design Guide, p. 122, vol. 37, Bennett Garfield.
- GOODYEAR, Unisteel G362, 2002 Tread Design Guide, p. 126, vol. 37, Bennett Garfield.
- MATADOR, MPS 400 Hwy, 2002 Tread Design Guide, p. 137, vol. 37, Bennett Garfield.
- REMINGTON, R819, 2002 Tread Design Guide, p. 143, vol. 37, Bennett Garfield.
- MICHELIN, Desert, 2002 Tread Design Guide, p. 211, vol. 37, Bennett Garfield.

\* cited by examiner

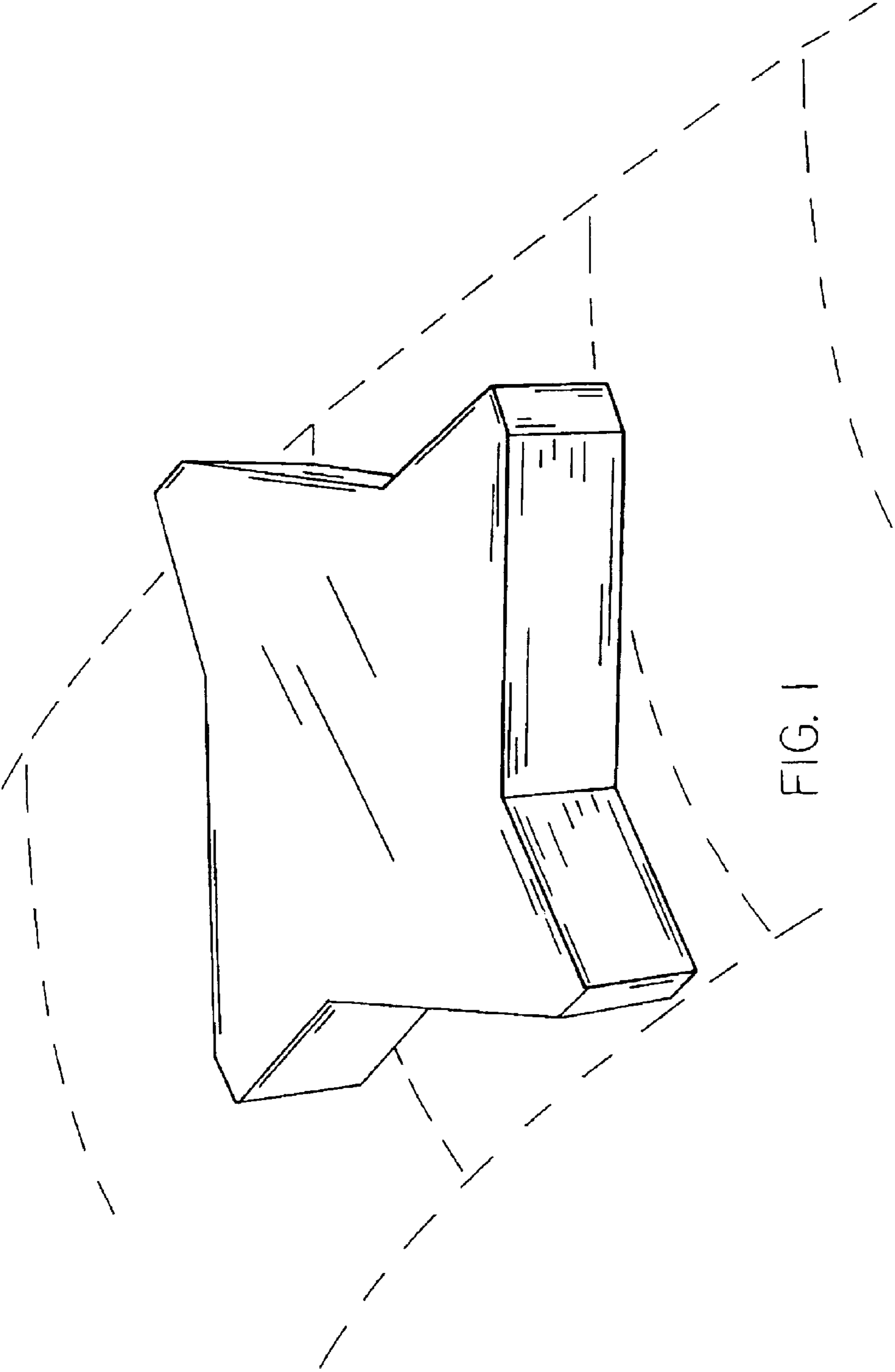

FIG. 1

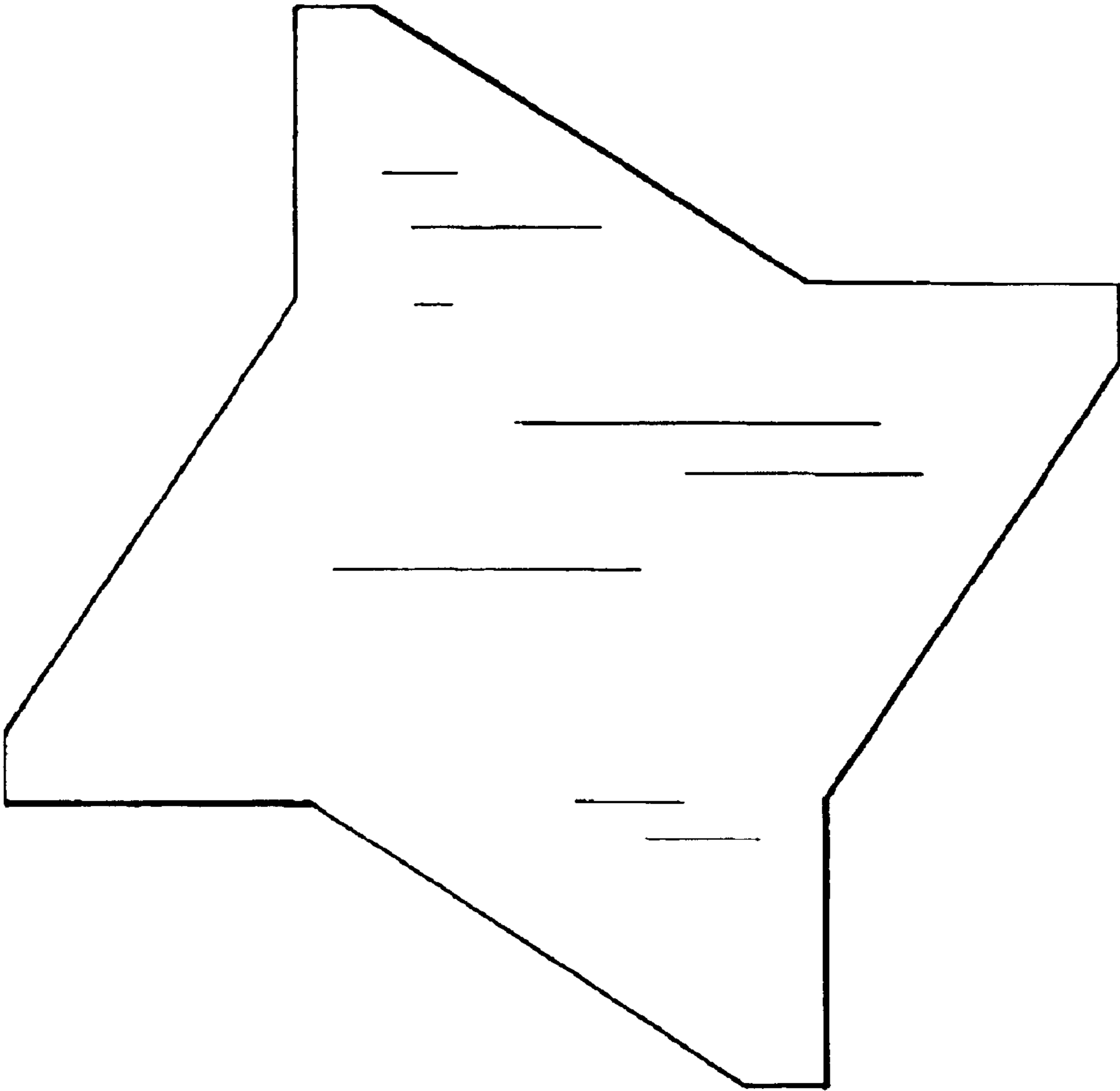

FIG. 2

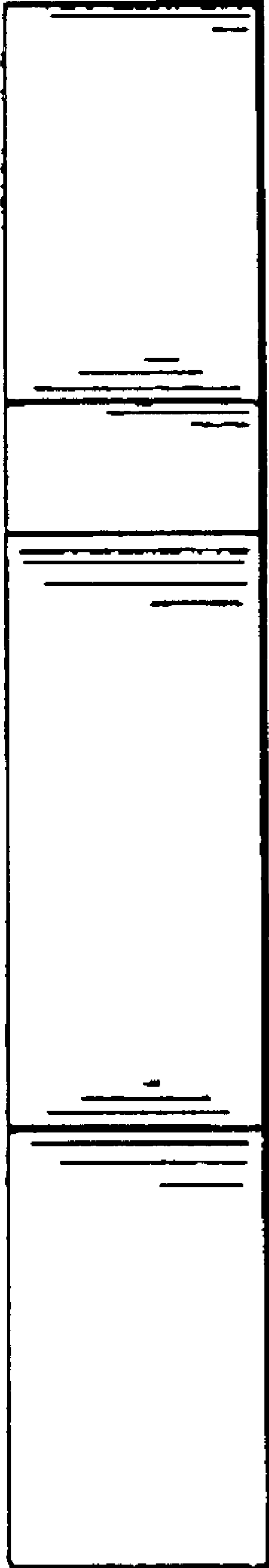

FIG. 3

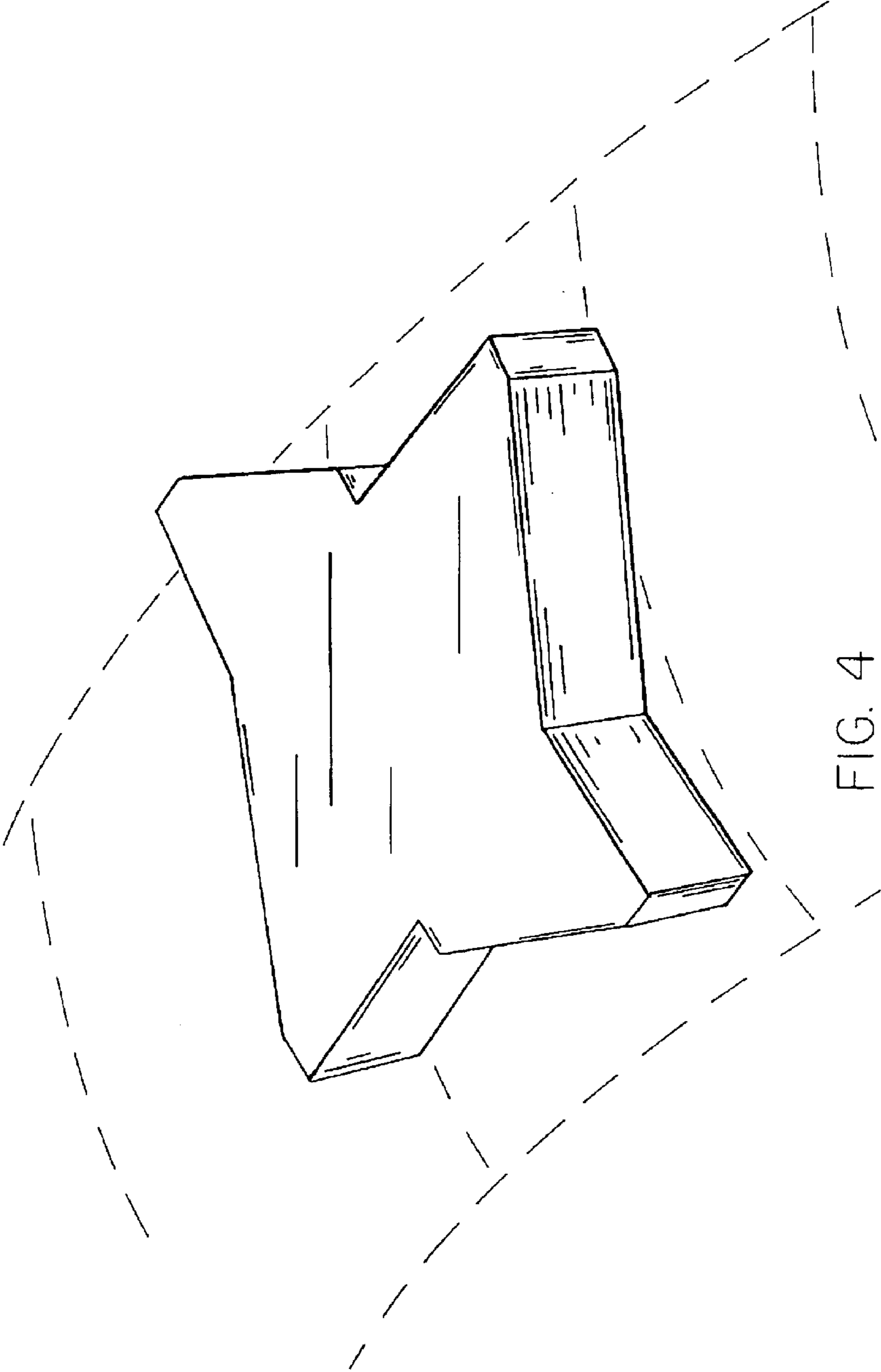

FIG. 4

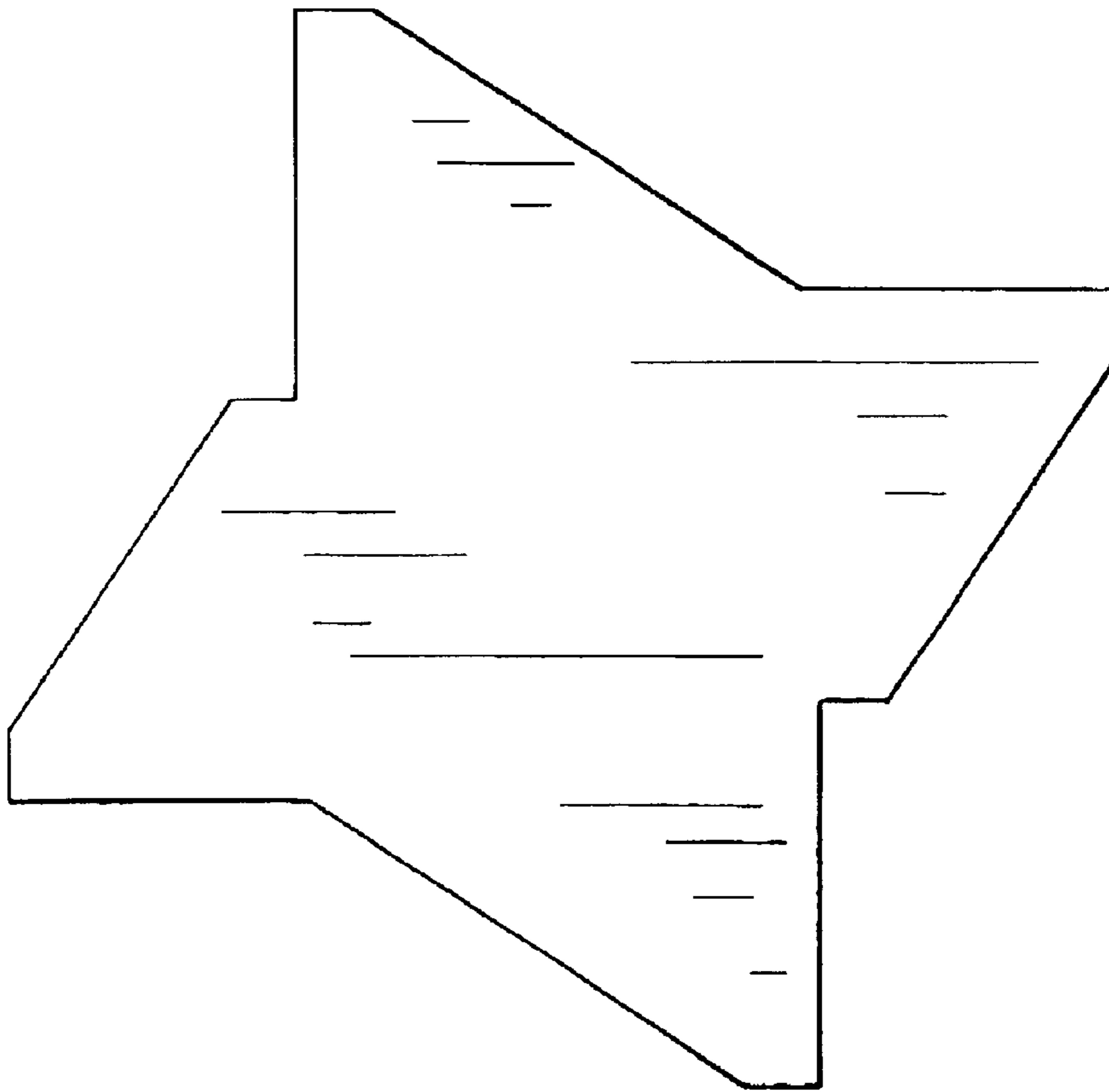

FIG. 5

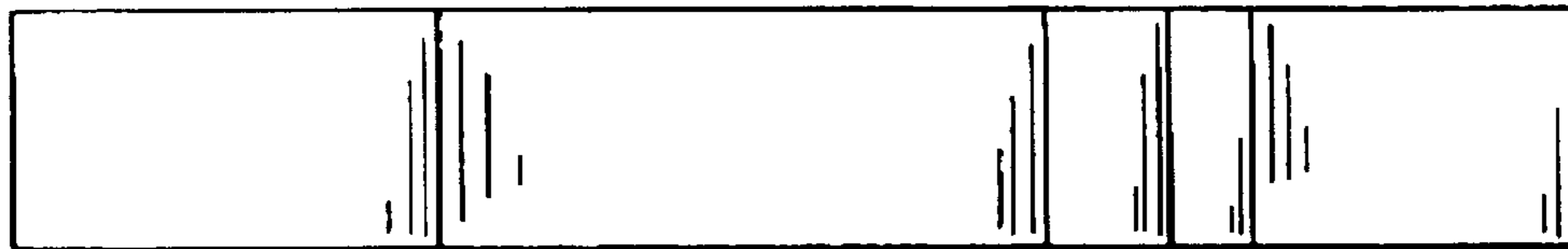

FIG. 6

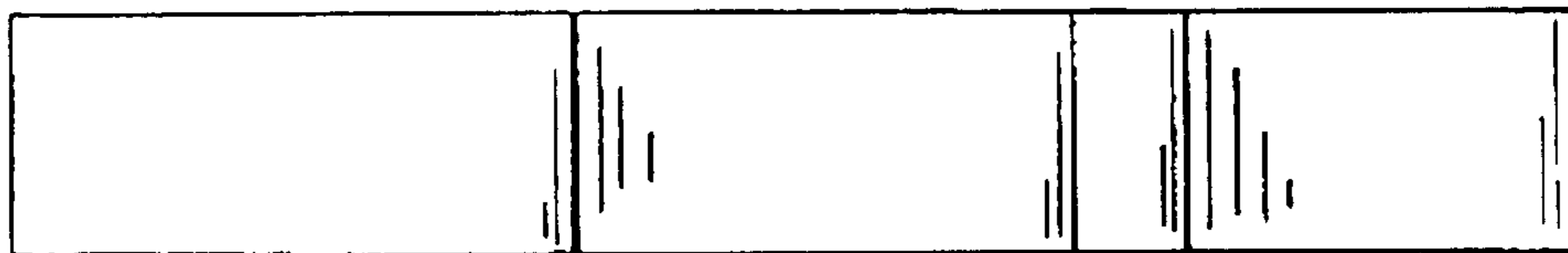

FIG. 7



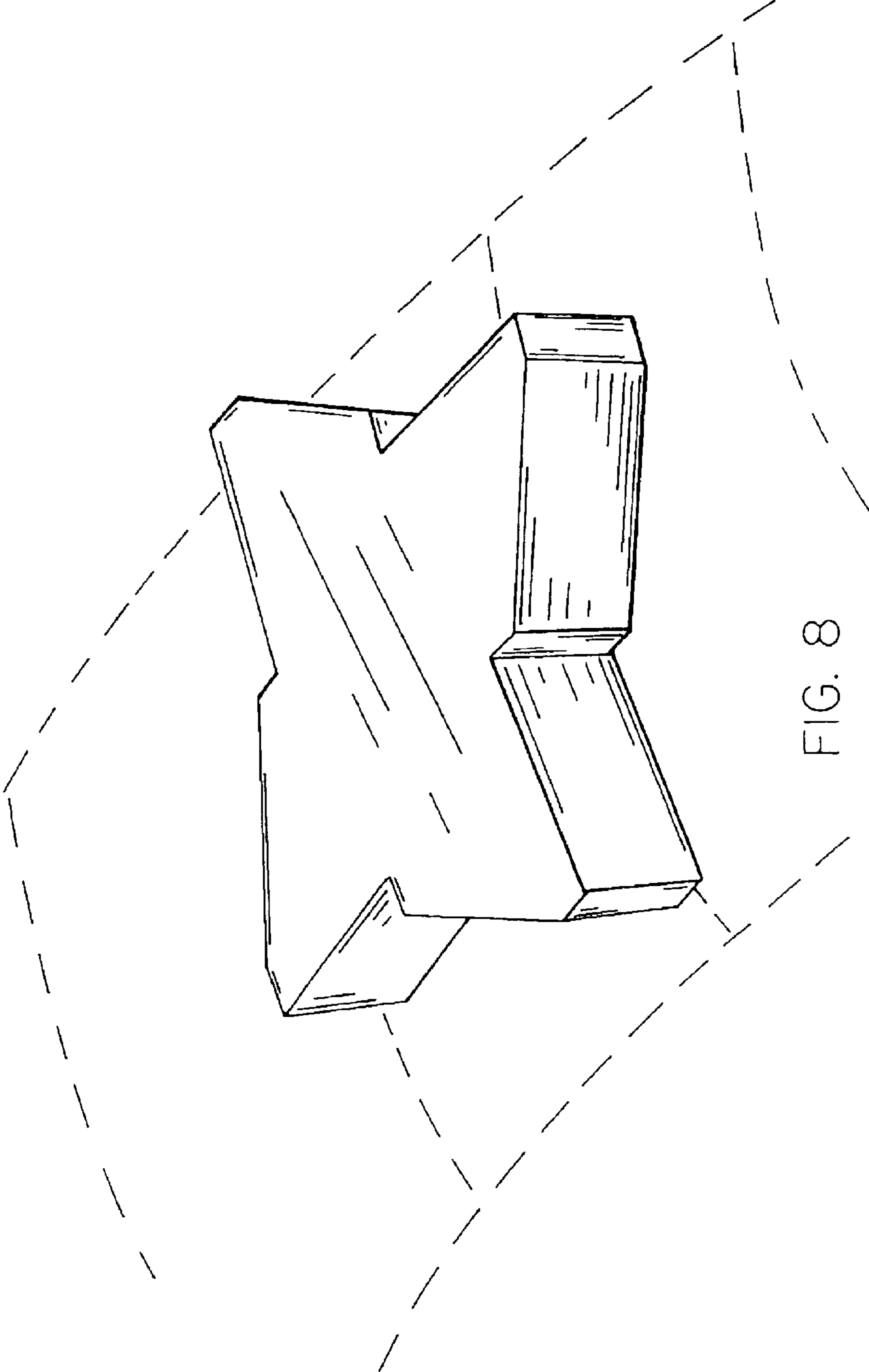

FIG. 8

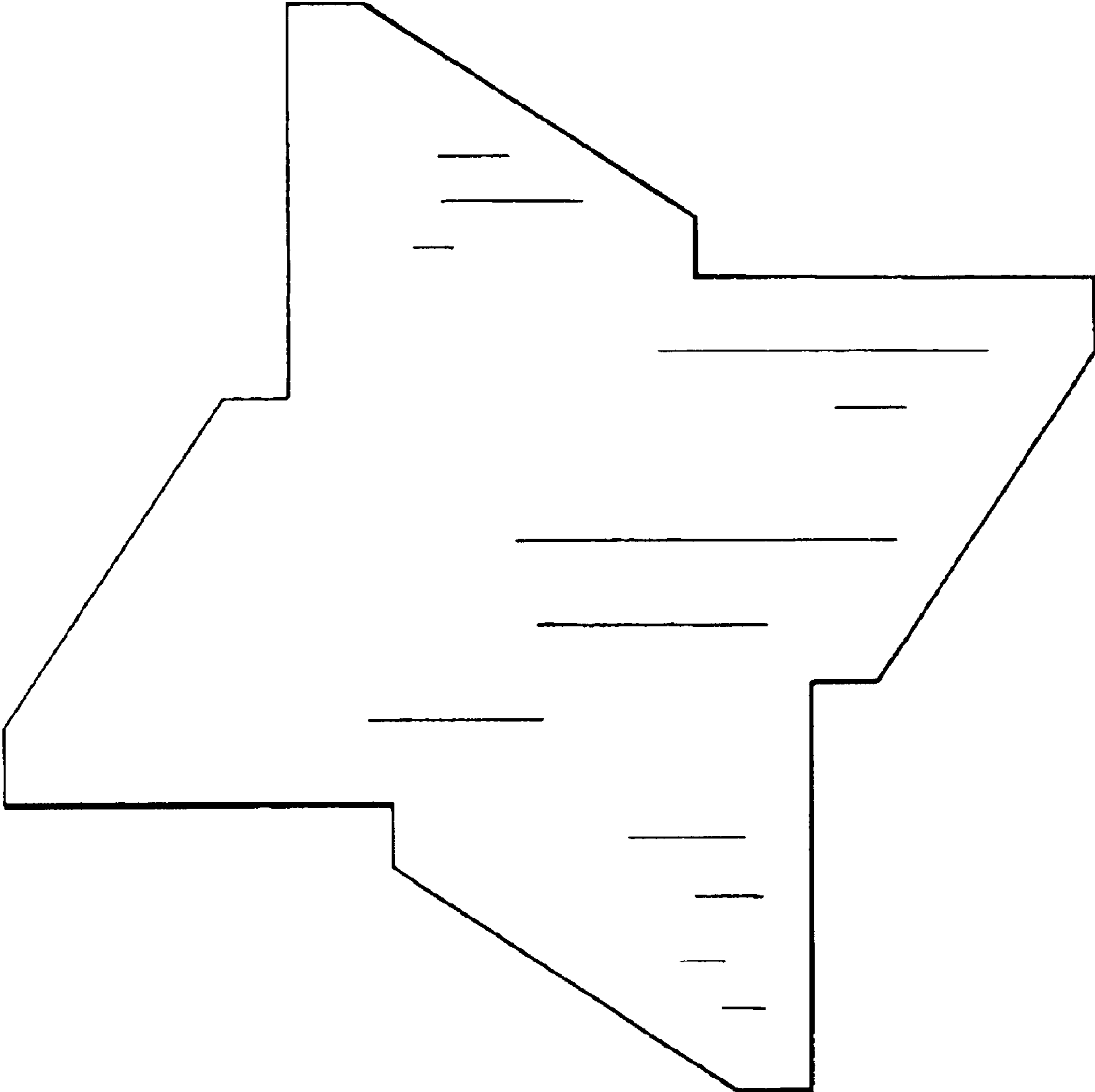

FIG. 9

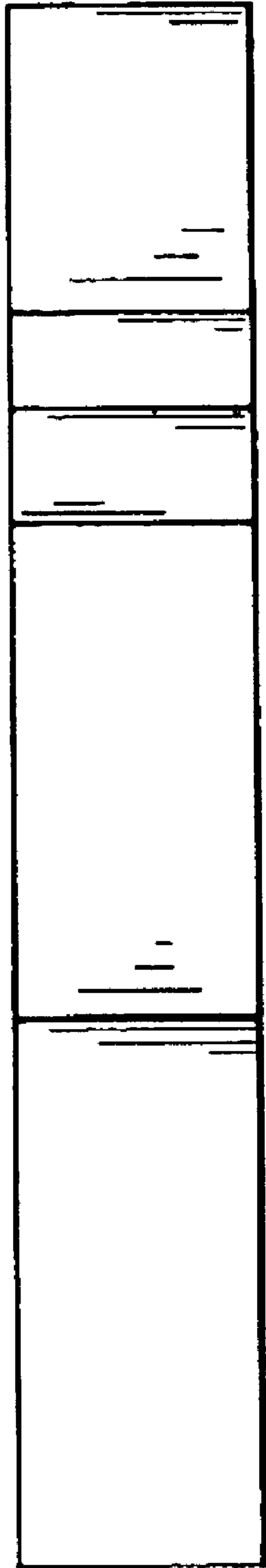

FIG. 10

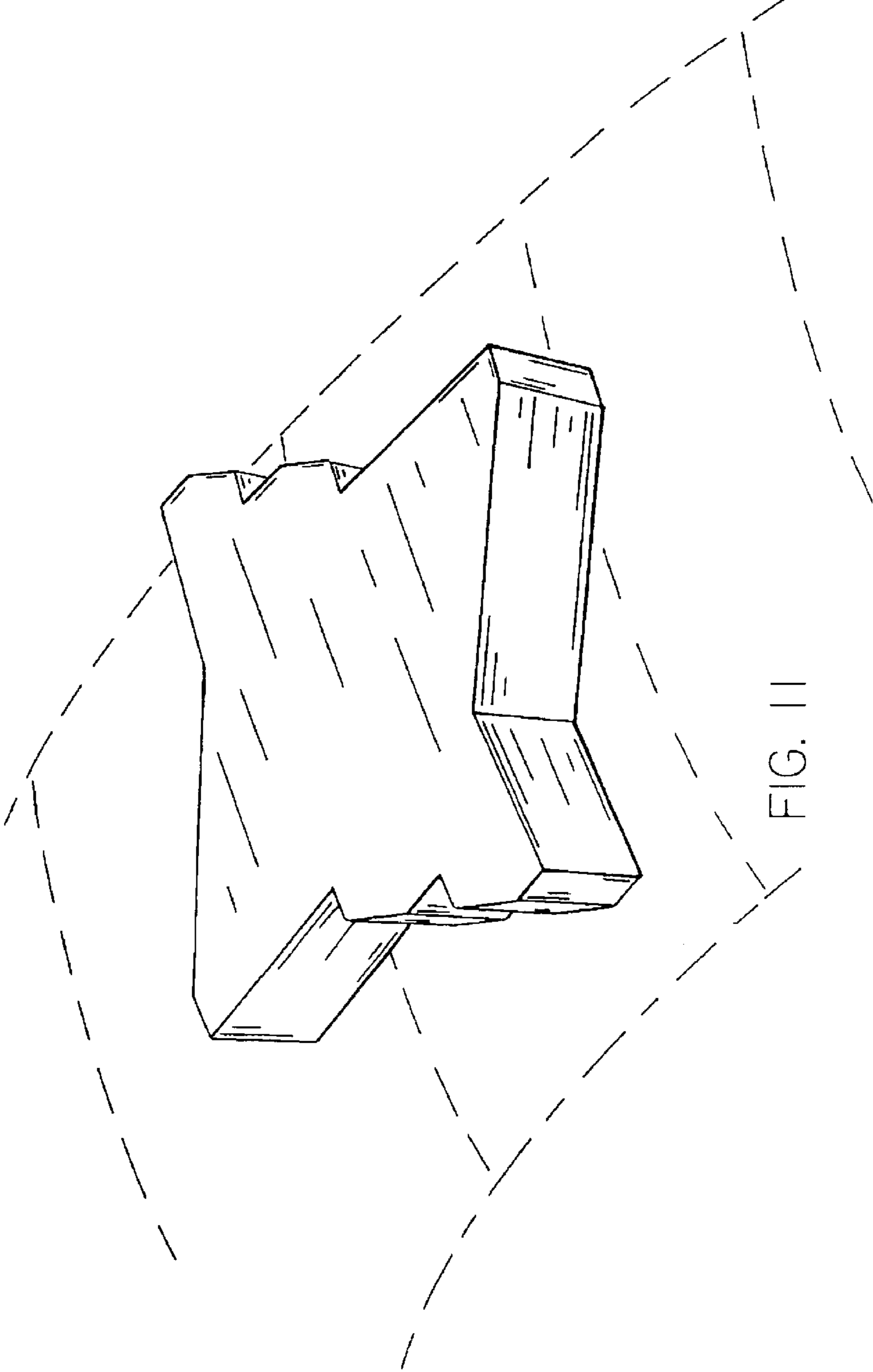

FIG. 11

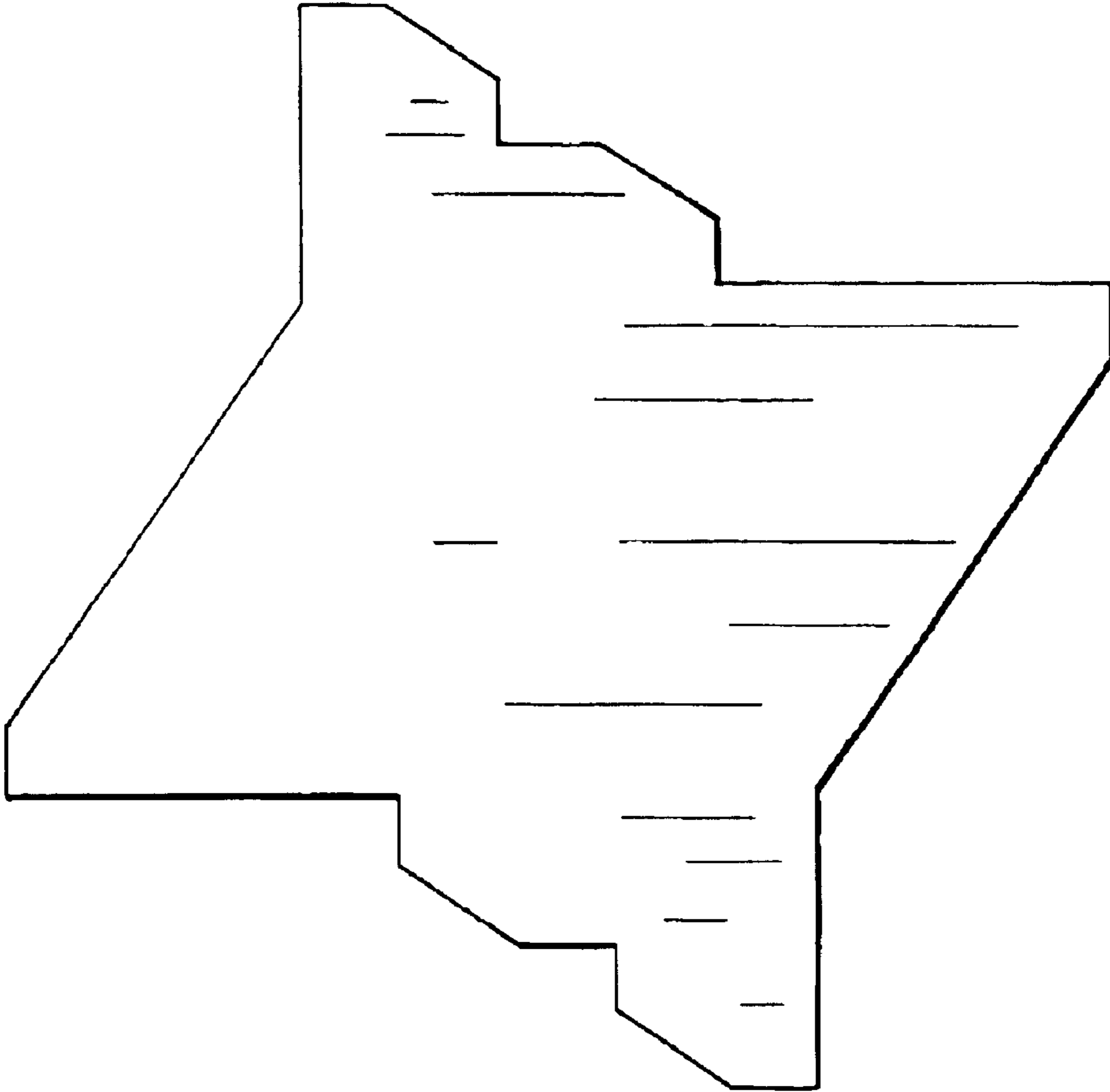

FIG. 12

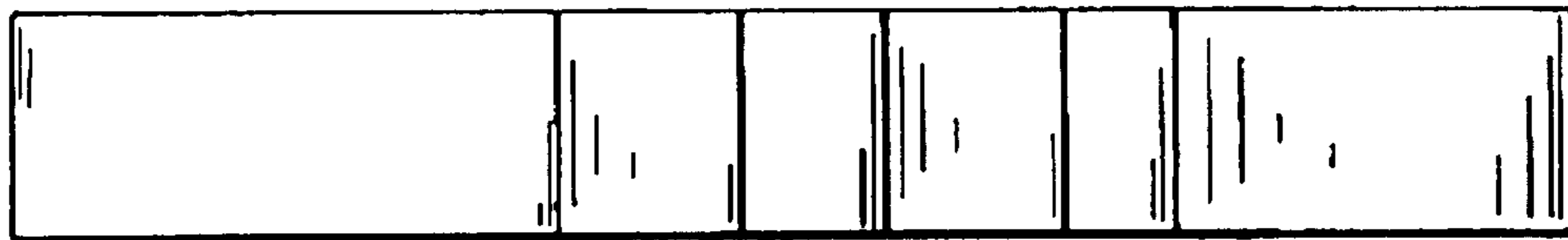

FIG. 13



FIG. 14