

US00D508430S

(12) **United States Design Patent**  
**Forster**

(10) **Patent No.:** **US D508,430 S**

(45) **Date of Patent:** **\*\* Aug. 16, 2005**

(54) **DRAINAGE BAG FOR PLANT POTS AND CONTAINERS**

3,739,522 A \* 6/1973 Greenbaum ..... 47/87  
5,781,981 A \* 7/1998 Weder et al. .... 29/450  
6,309,731 B1 \* 10/2001 Takeuchi et al. .... 428/154

(76) **Inventor:** **Alexander R. Forster**, 31 Glenthorne Road, Kingston Upon Thames Surrey, KT12UB (GB)

\* cited by examiner

*Primary Examiner*—Joel A. Sincavage

*Assistant Examiner*—Elizabeth Albert

(\*\*) **Term:** **14 Years**

(57) **CLAIM**

(21) **Appl. No.:** **29/185,754**

The ornamental design for a drainage bag for plant pots and containers, as shown and described.

(22) **Filed:** **Jul. 3, 2003**

(51) **LOC (8) Cl.** ..... **11-02**

(52) **U.S. Cl.** ..... **D11/156**

(58) **Field of Search** ..... D11/143, 144,  
D11/145, 146, 147, 148, 149, 150, 151,  
152, 153, 154, 155, 156, 164; 47/41.01,  
65.5, 65.7, 66.1, 66.5, 66.6, 68, 72, 73;  
206/423

**DESCRIPTION**

FIG. 1 is a top plan view of a drainage bag for plant pots and containers showing my new design;

FIG. 2 is a front elevational view of the drainage bag for plant pots and containers; and,

FIG. 3 is a perspective view of the drainage bag for plant pots and containers.

The broken lines showing the container in FIG. 3 are for information purposes only and form no part of the claimed design.

(56) **References Cited**

**U.S. PATENT DOCUMENTS**

3,375,607 A \* 4/1968 Melvold ..... 47/74  
3,722,502 A \* 3/1973 Besuner et al. .... 600/575

**1 Claim, 2 Drawing Sheets**

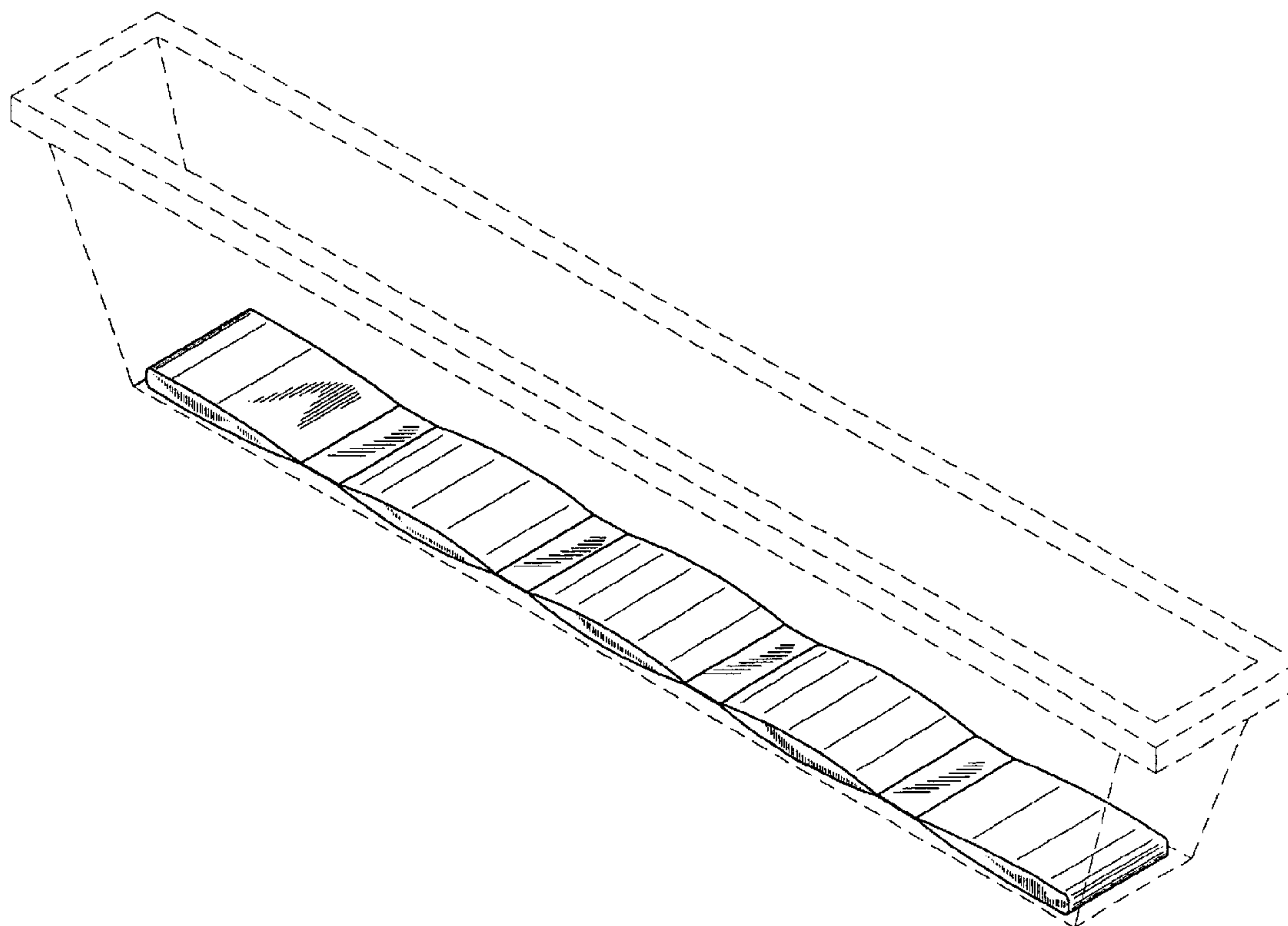

FIG. 1

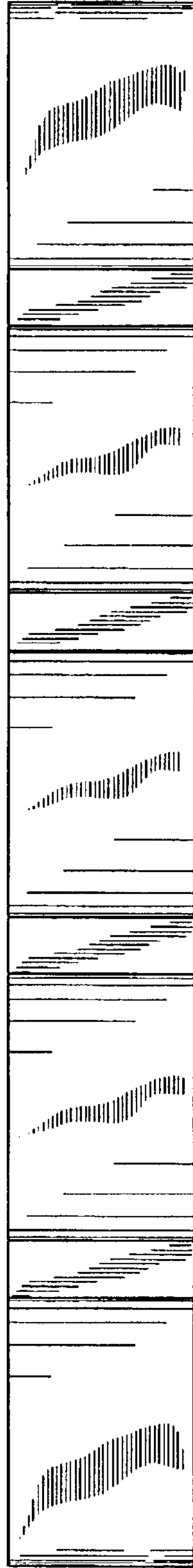

FIG. 2



FIG. 3

