

US00D508337S

(12) **United States Design Patent** (10) **Patent No.:** **US D508,337 S**
Stalmate et al. (45) **Date of Patent:** **** Aug. 16, 2005**

(54) **SEATING SURFACE FOR A VEHICLE SEAT**

(75) Inventors: **Robert L. Stalmate**, Chillicothe, IL (US); **Lyle E. York**, Peoria, IL (US); **Vijayakumar Ramasamy**, Peoria, IL (US)

(73) Assignee: **Caterpillar Inc**, Peoria, IL (US)

(**) Term: **14 Years**

(21) Appl. No.: **29/188,910**

(22) Filed: **Aug. 27, 2003**

(51) **LOC (8) Cl.** **06-01**

(52) **U.S. Cl.** **D6/356**

(58) **Field of Search** D6/334, 356, 367, D6/368, 374, 375, 381, 500-502; 297/232, 284.3, 353, 452.24, 452.26, 452.34, 452.35

(56) **References Cited**

U.S. PATENT DOCUMENTS

3,924,893 A	*	12/1975	Ferrara	297/452.34
D249,102 S		8/1978	Pelly	D6/48
D273,920 S		5/1984	Tixier	D6/48
D315,255 S		3/1991	Beermann	D6/356
D317,533 S		6/1991	Beermann	D6/356
D317,534 S		6/1991	Hänsel	D6/356
D321,095 S		10/1991	Bockwoldt	D6/356
D326,568 S		6/1992	Lanius et al.	D6/356
D326,959 S		6/1992	VanDuser et al.	D6/356
D326,960 S		6/1992	Stulik	D6/356
D330,118 S	*	10/1992	Lanius et al.	D6/356
D332,181 S		1/1993	Sacco et al.	D6/356
D354,629 S		1/1995	Chapman	D6/356
D354,868 S		1/1995	Bowlby	D6/356
D356,694 S		3/1995	Armbrecht	D6/356
D357,363 S		4/1995	Frankhouse et al.	D6/356
D358,262 S		5/1995	Smoczynski	D6/356
D362,126 S		9/1995	Carter	D6/356
D371,465 S	*	7/1996	Stulik	D6/356
D383,320 S	*	9/1997	Gilbertson	D6/356
D385,117 S		10/1997	Tomforde et al.	D6/356
D385,709 S	*	11/1997	Gryp	D6/356

D387,914 S	12/1997	Beermann et al.	D6/356
D388,966 S	1/1998	Beermann et al.	D6/356
D391,087 S	2/1998	Sacco et al.	D6/356
D391,410 S	3/1998	Tomforde et al.	D6/356
D392,116 S	3/1998	Tomforde et al.	D6/356
D396,152 S	7/1998	Beermann et al.	D6/356
D404,927 S	2/1999	Blomdell et al.	D6/356
D405,281 S	2/1999	Blomdell et al.	D6/356
D411,377 S	6/1999	Sacco et al.	D6/356
D411,690 S	6/1999	Kneip et al.	D6/356
D416,696 S	11/1999	Slanec et al.	D6/356
D426,392 S	6/2000	Ott et al.	D6/356
D428,719 S	8/2000	Fick et al.	D6/356
D440,062 S	4/2001	Tsay	D6/356
D442,376 S	5/2001	Norman	D6/356
D453,425 S	2/2002	Clarke	D6/356
D458,465 S	6/2002	Boulay et al.	D5/356

* cited by examiner

Primary Examiner—Mimosa De

(74) *Attorney, Agent, or Firm*—Finnegan, Henderson, Farabow, Garrett & Dunner

(57) **CLAIM**

The ornamental design for a seating surface for a vehicle seat, as shown and described.

DESCRIPTION

FIG. 1 is a front-left perspective view showing a seating surface for a vehicle seat of our new design;
 FIG. 2 is a front view thereof;
 FIG. 3 is a rear view thereof;
 FIG. 4 is a left-side view thereof;
 FIG. 5 is a right-side view thereof;
 FIG. 6 is a top view thereof; and,
 FIG. 7 is a bottom view thereof.

The bottom and rear of the seating surface for a vehicle seat is not visible during normal use and does not form part of the claimed design. The broken lines in the figures are for illustrative purposes only and do not form part of the claimed invention.

1 Claim, 7 Drawing Sheets

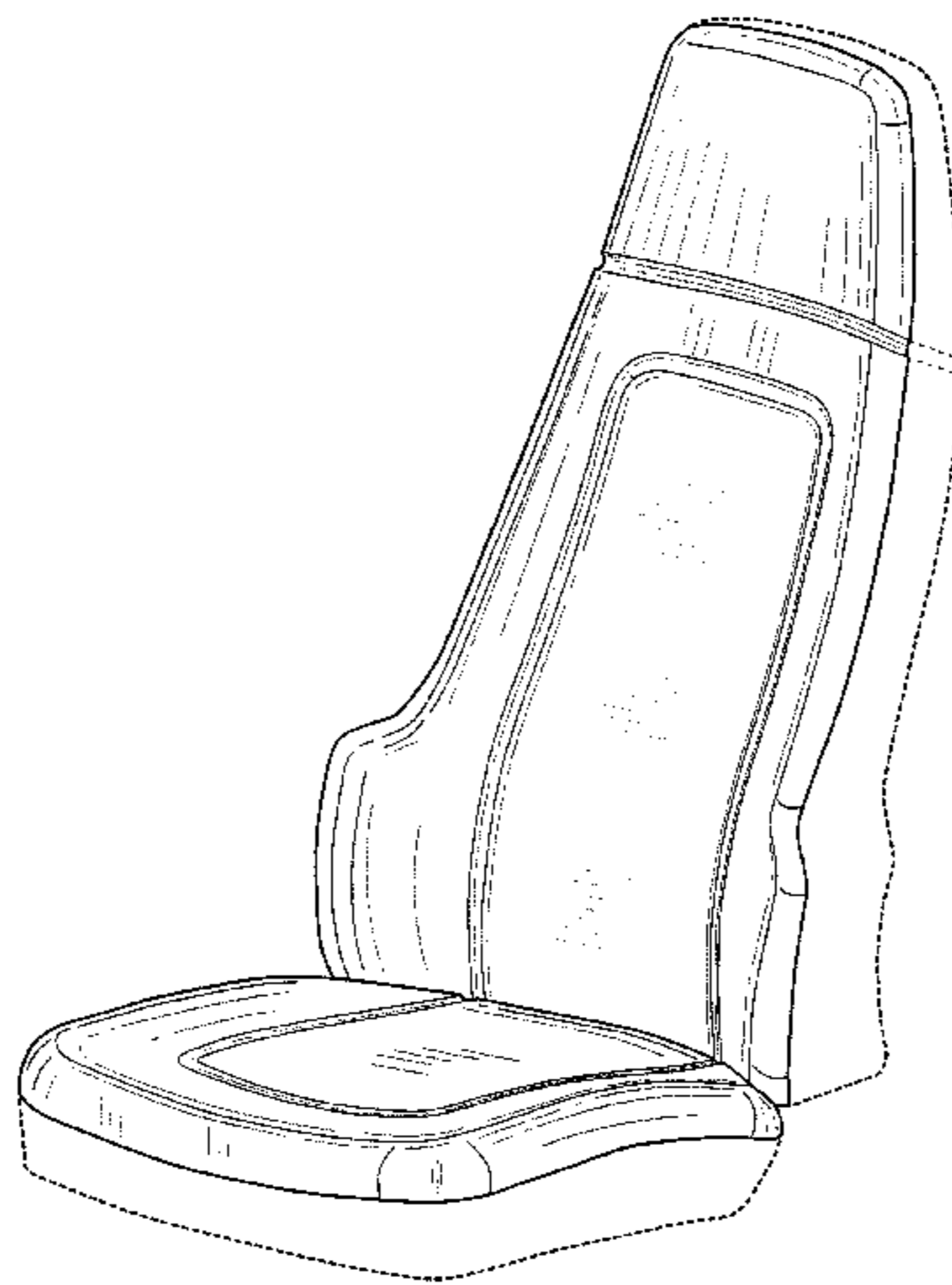

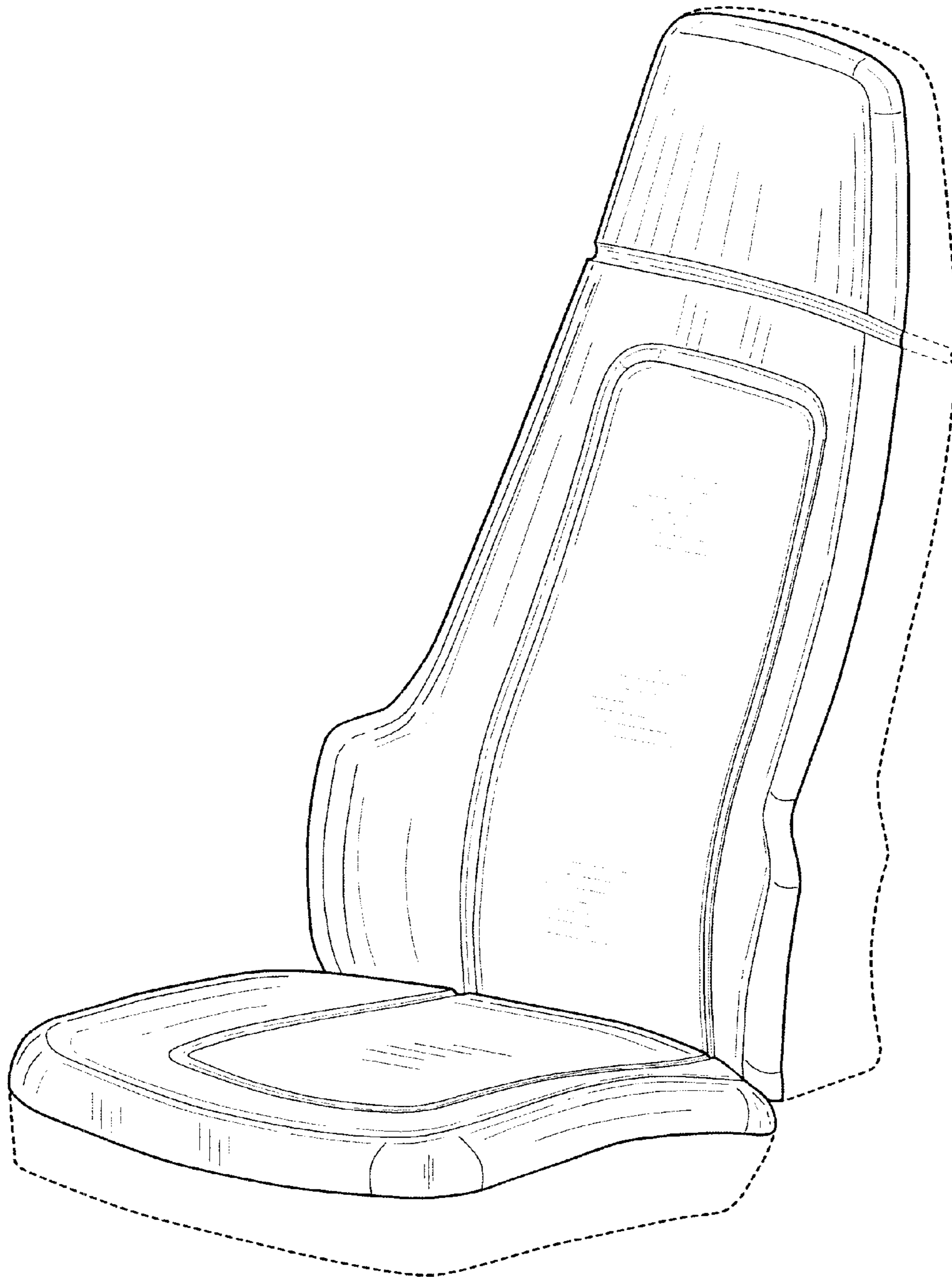

FIG. 1

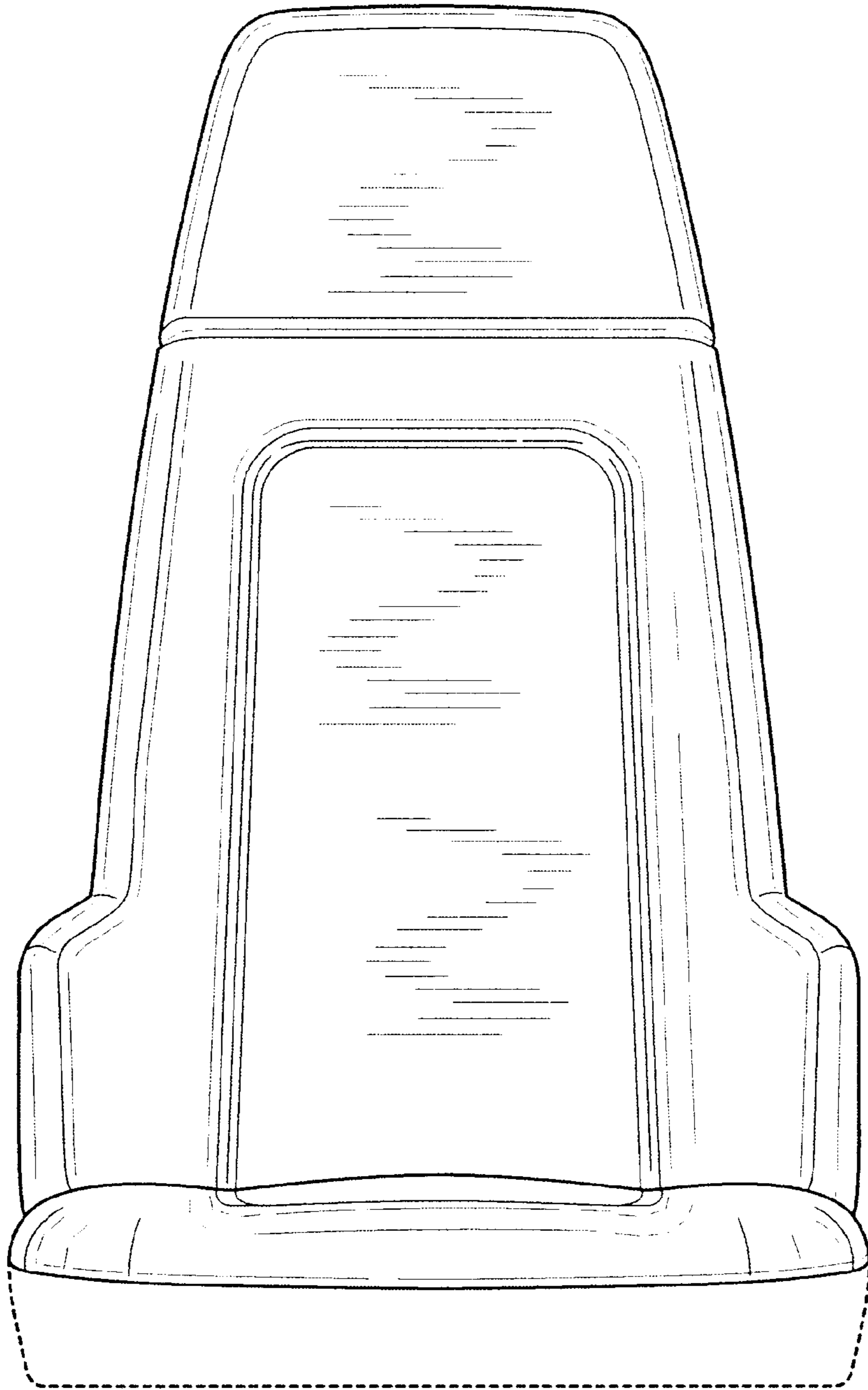

FIG. 2

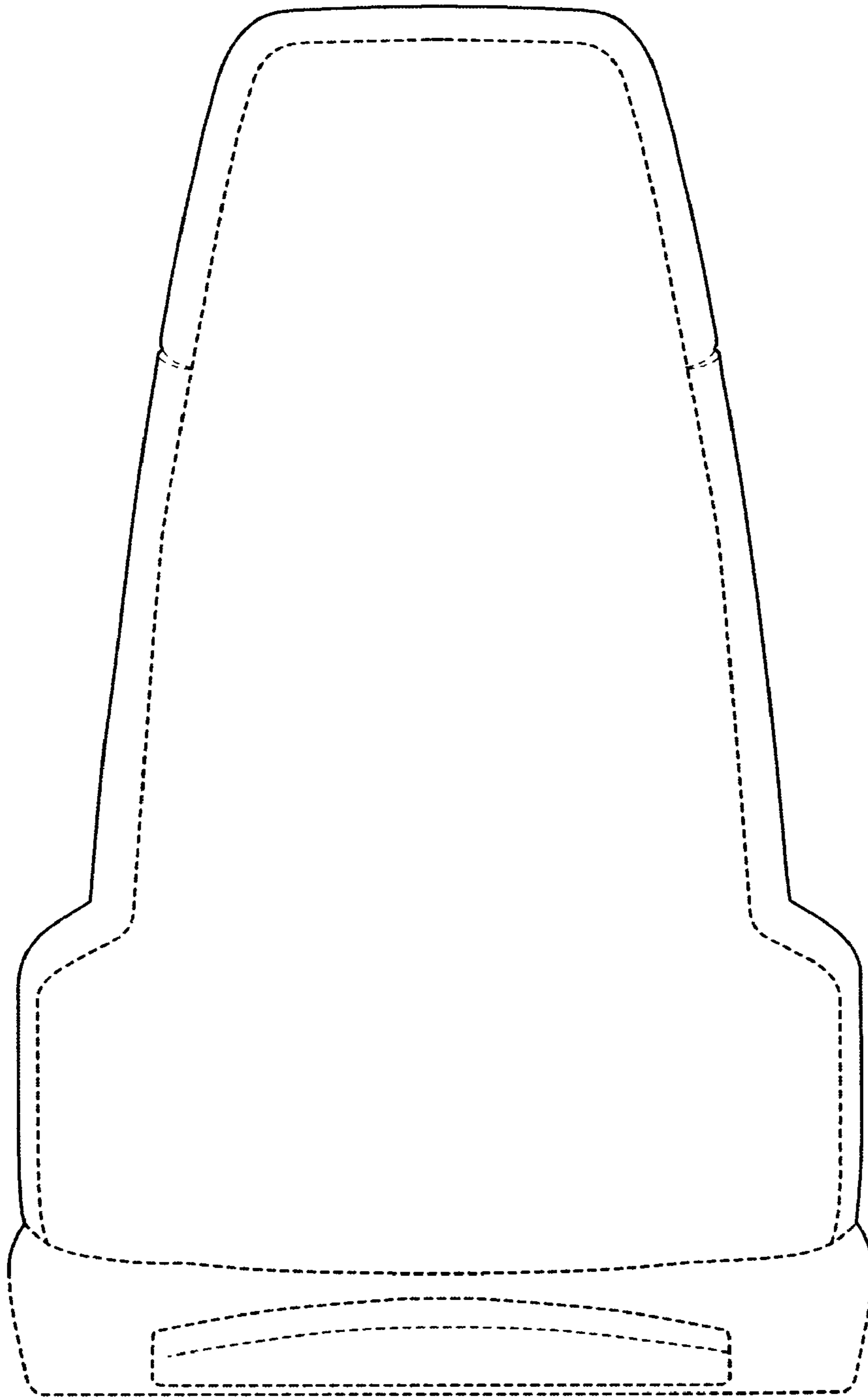

FIG. 3

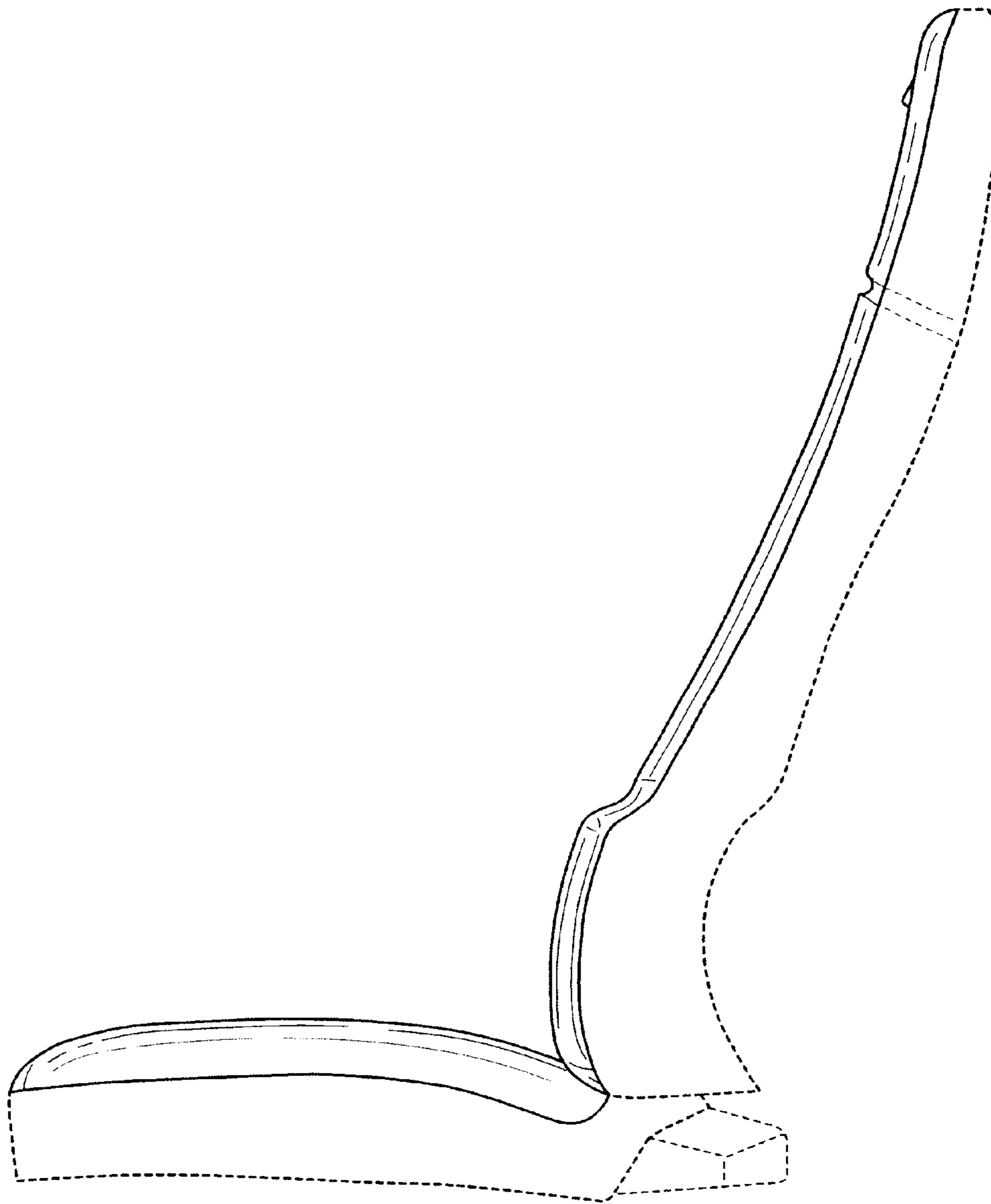

FIG. 4

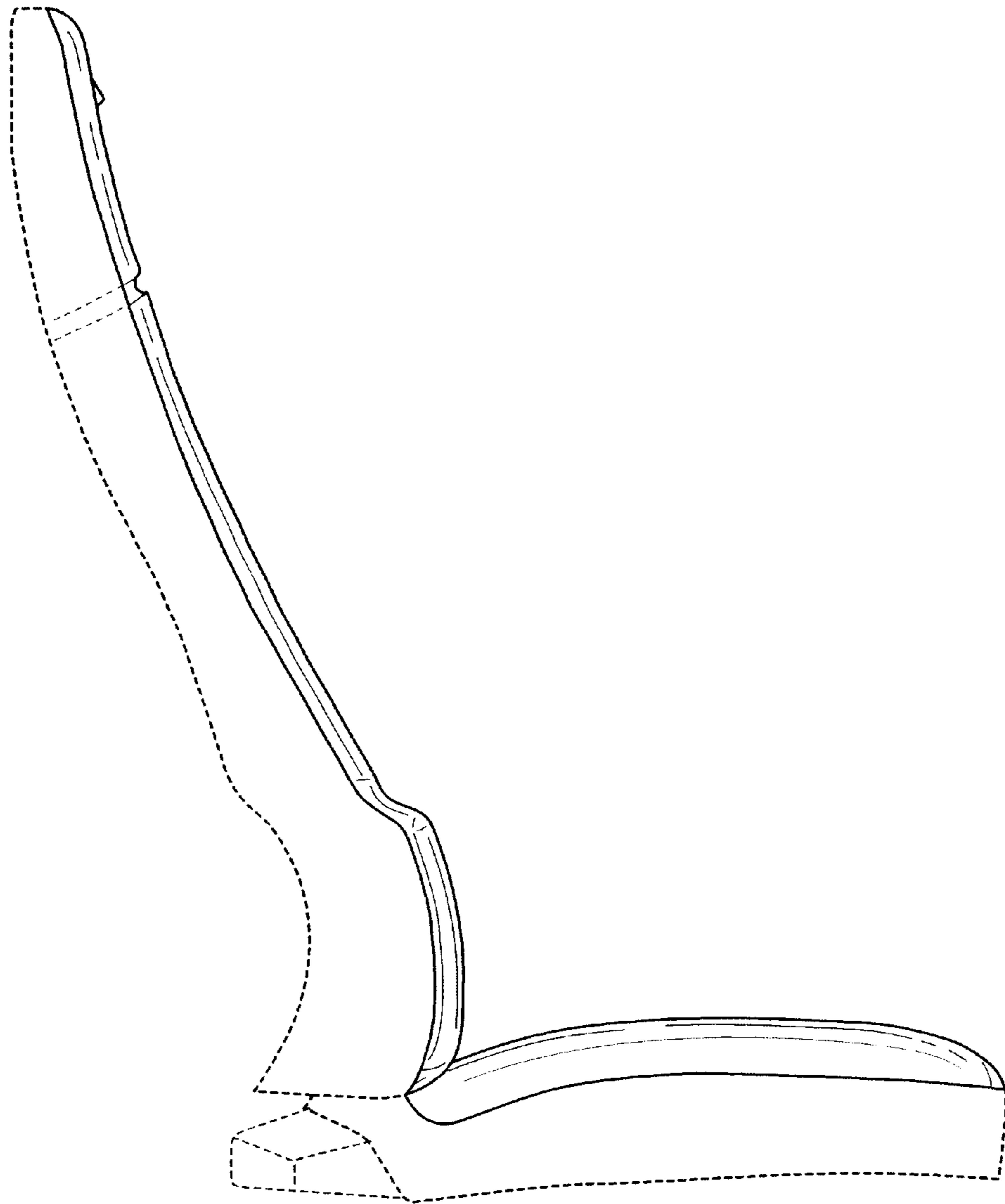

FIG. 5

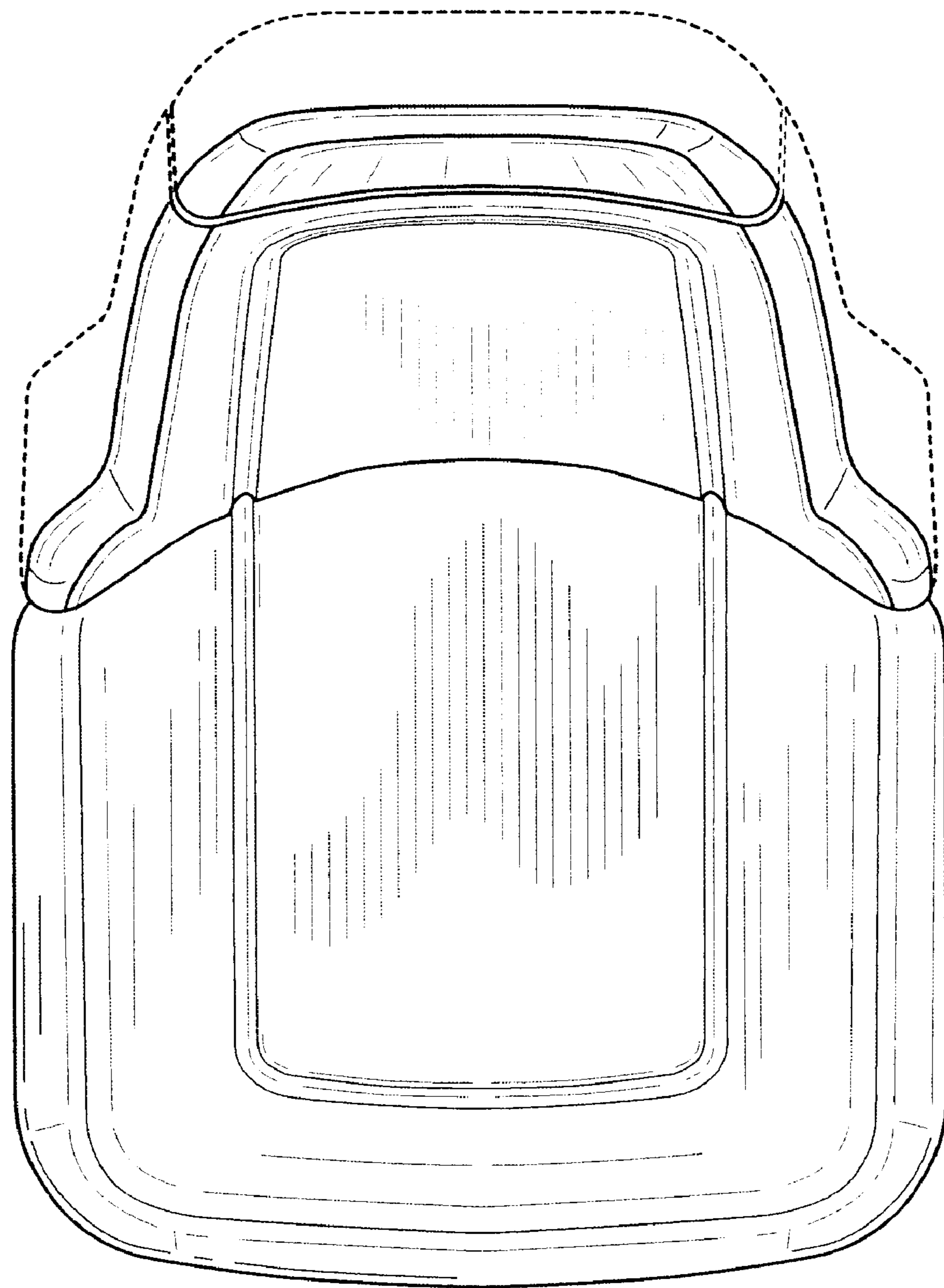

FIG. 6

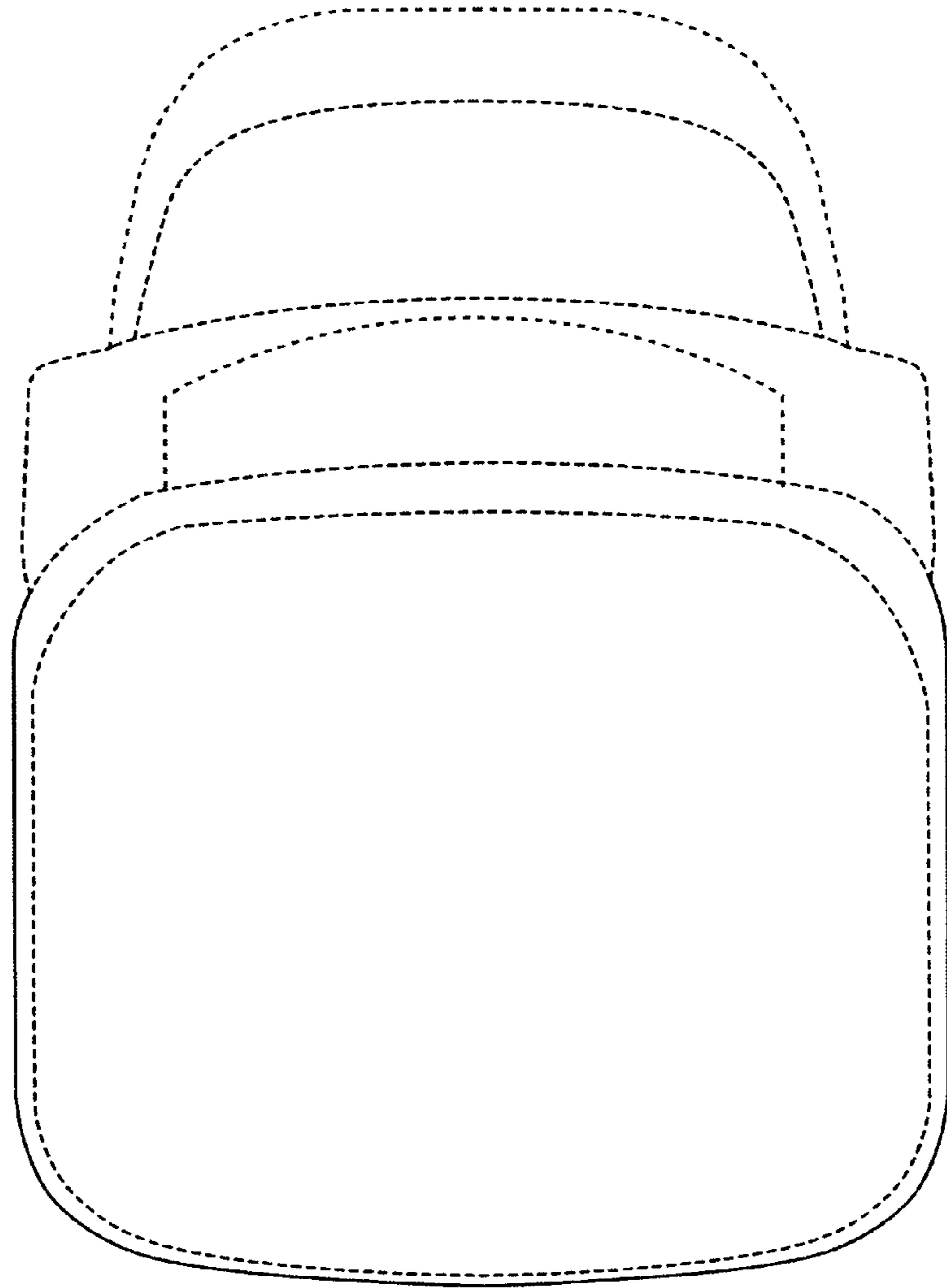

FIG. 7

UNITED STATES PATENT AND TRADEMARK OFFICE
CERTIFICATE OF CORRECTION

PATENT NO. : Des. 508,337 S
DATED : August 16, 2005
INVENTOR(S) : Robert L. Stamate et al.

Page 1 of 1

It is certified that error appears in the above-identified patent and that said Letters Patent is hereby corrected as shown below:

Title page.

Item [12], should read -- **Stamate** --.

Item [75], Inventors, "**Robert L. Stalmate**" should read -- **Robert L. Stamate** --.

Signed and Sealed this

Twenty-ninth Day of November, 2005

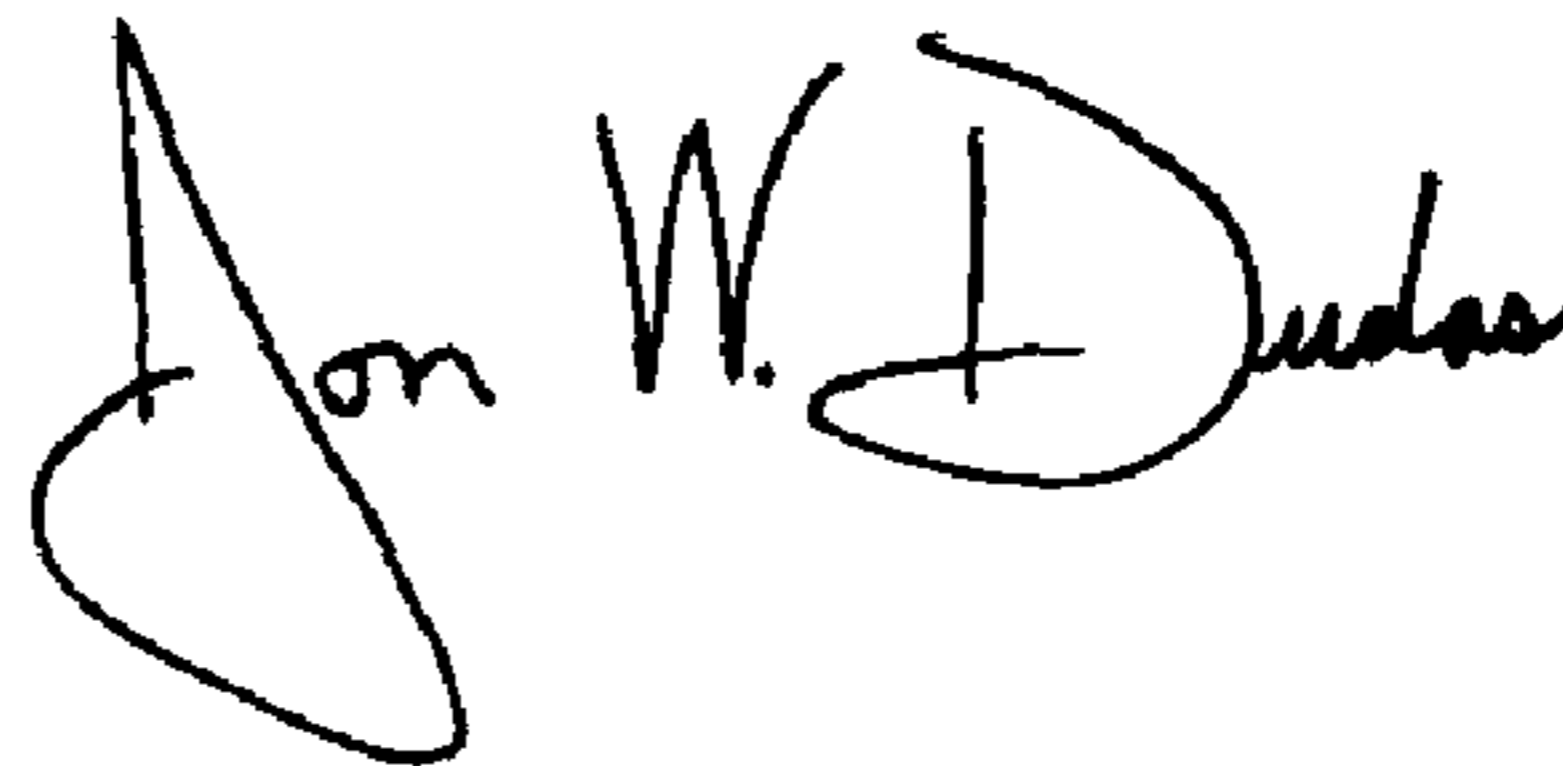
A handwritten signature in black ink, reading "Jon W. Dudas". The signature is written in a cursive style with a large, looped initial "J".

JON W. DUDAS

Director of the United States Patent and Trademark Office