



US00D508235S

(12) **United States Design Patent**
Suenaga

(10) **Patent No.:** **US D508,235 S**
(45) **Date of Patent:** **** Aug. 9, 2005**

(54) **LIGHT EMITTING DIODE**

(75) **Inventor:** **Ryoma Suenaga, Komatsushima (JP)**

(73) **Assignee:** **Nichia Corporation, Anan (JP)**

(**) **Term:** **14 Years**

(21) **Appl. No.:** **29/206,789**

(22) **Filed:** **Jun. 4, 2004**

(30) **Foreign Application Priority Data**

Dec. 5, 2003	(JP)	2003-036142
Dec. 5, 2003	(JP)	2003-036143
Dec. 5, 2003	(JP)	2003-036144
Dec. 5, 2003	(JP)	2003-036145
Dec. 5, 2003	(JP)	2003-036146

(51) **LOC (8) Cl.** **13-03**

(52) **U.S. Cl.** **D13/180**

(58) **Field of Search** D13/180, 182;
174/52.4; 257/81, 91, 99, 431, 433, 466,
E33.057, 666; 313/500; 315/169.2, 169.3;
331/68; 333/203

(56) **References Cited**

U.S. PATENT DOCUMENTS

4,963,843 A * 10/1990 Peckham 333/203

(Continued)

Primary Examiner—Stella Reid

Assistant Examiner—Selina Sikder

(74) *Attorney, Agent, or Firm*—Smith Patent Office

(57) **CLAIM**

I claim the ornamental design for the light emitting diode, as shown and described.

DESCRIPTION

FIG. 1 is a top plan view of the light emitting diode showing my new design;

FIG. 2 is a left view of the light emitting diode according to the embodiment of FIG. 1;

FIG. 3 is a front elevational view of the light emitting diode according to the embodiment of FIG. 1;

FIG. 4 is a right view of the light emitting diode according to the embodiment of FIG. 1;

FIG. 5 is a bottom plan of the light emitting diode according to the embodiment of FIG. 1;

FIG. 6 is a rear elevational view of the light emitting diode according to the embodiment of FIG. 1;

FIG. 7 is a perspective view of a light emitting diode according to the embodiment of FIG. 1;

FIG. 8 is a top plan view of a light emitting diode according to another embodiment of my new design;

FIG. 9 is a left view of the light emitting diode according to the embodiment of FIG. 8;

FIG. 10 is a front elevational view of the light emitting diode according to the embodiment of FIG. 8;

FIG. 11 is a right view of the light emitting diode according to the embodiment of FIG. 8;

FIG. 12 is a bottom plan of the light emitting diode according to the embodiment of FIG. 8;

FIG. 13 is a rear elevational view of the light emitting diode according to the embodiment of FIG. 8;

FIG. 14 is a perspective view of a light emitting diode according to the embodiment of FIG. 8;

FIG. 15 is a top plan view of a light emitting diode according to still another embodiment of my new design;

FIG. 16 is a left view of the light emitting diode according to the embodiment of FIG. 15;

FIG. 17 is a front elevational view of the light emitting diode according to the embodiment of FIG. 15;

FIG. 18 is a right view of the light emitting diode according to the embodiment of FIG. 15;

FIG. 19 is a bottom plan of the light emitting diode according to the embodiment of FIG. 15;

FIG. 20 is a rear elevational view of the light emitting diode according to the embodiment of FIG. 15;

FIG. 21 is a perspective view of a light emitting diode according to the embodiment of FIG. 15;

FIG. 22 is a top plan view of a light emitting diode according to still another embodiment of my new design;

FIG. 23 is a left view of the light emitting diode according to the embodiment of FIG. 22;

FIG. 24 is a front elevational view of the light emitting diode according to the embodiment of FIG. 22;

FIG. 25 is a right view of the light emitting diode according to the embodiment of FIG. 22;

FIG. 26 is a bottom plan of the light emitting diode according to the embodiment of FIG. 22;

FIG. 27 is a rear elevational view of the light emitting diode according to the embodiment of FIG. 22; and,

FIG. 28 is a perspective view of a light emitting diode according to the embodiment of FIG. 22.

1 Claim, 8 Drawing Sheets

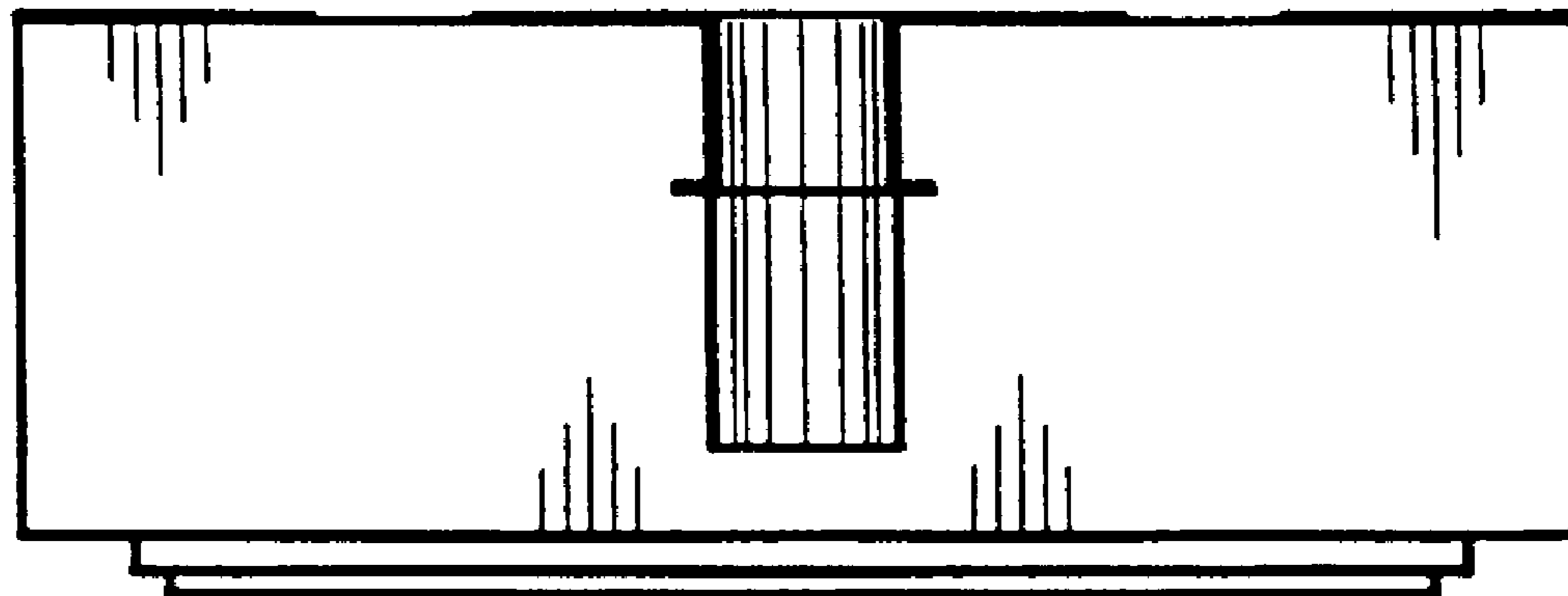

US D508,235 S

Page 2

U.S. PATENT DOCUMENTS

5,682,674 A	*	11/1997	Yamazaki et al.	29/830	6,355,946 B1	*	3/2002	Ishinaga	257/98
5,966,052 A	*	10/1999	Sakai	331/68	6,383,835 B1	*	5/2002	Hata et al.	438/65
RE36,614 E	*	3/2000	Lumbard et al.	313/500	6,495,861 B1	*	12/2002	Ishinaga	257/99
6,079,099 A	*	6/2000	Uchida et al.	29/837	6,593,598 B2	*	7/2003	Ishinaga	257/98
6,093,940 A	*	7/2000	Ishinaga et al.	257/99	2002/0167063 A1	*	11/2002	Fujimoto et al.	257/435

* cited by examiner

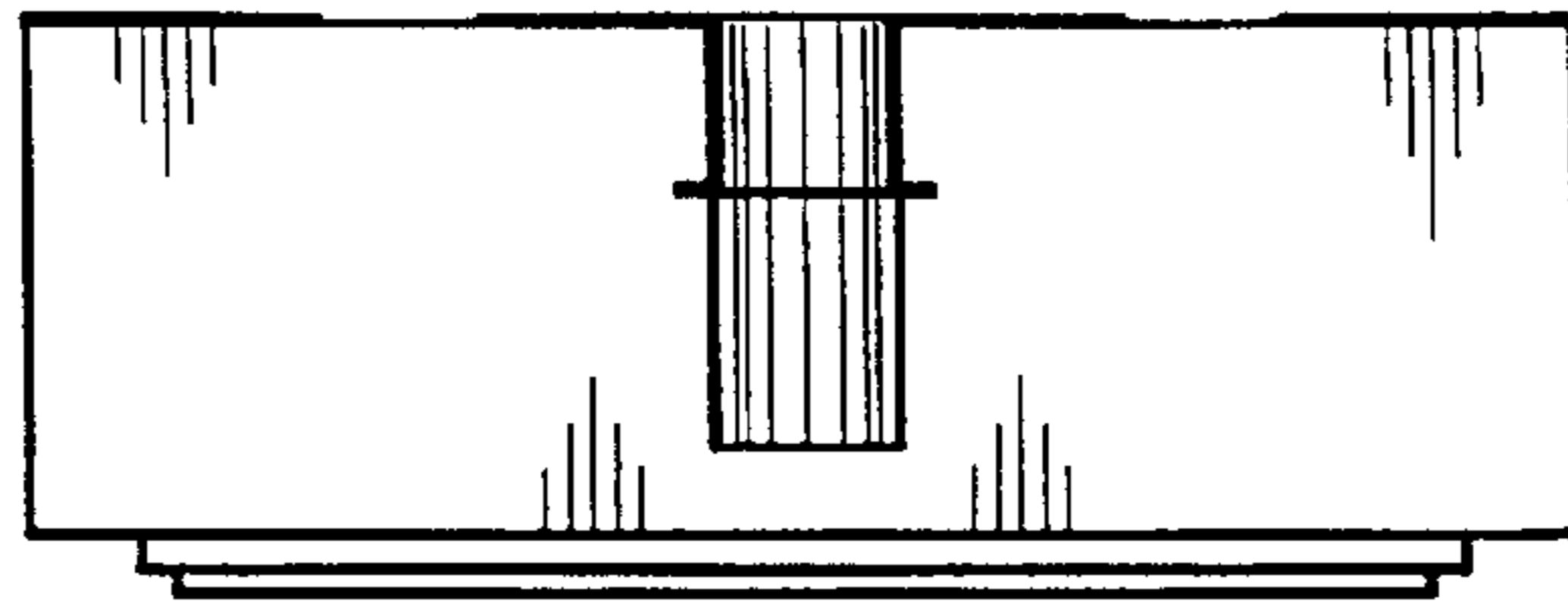

Fig. 1

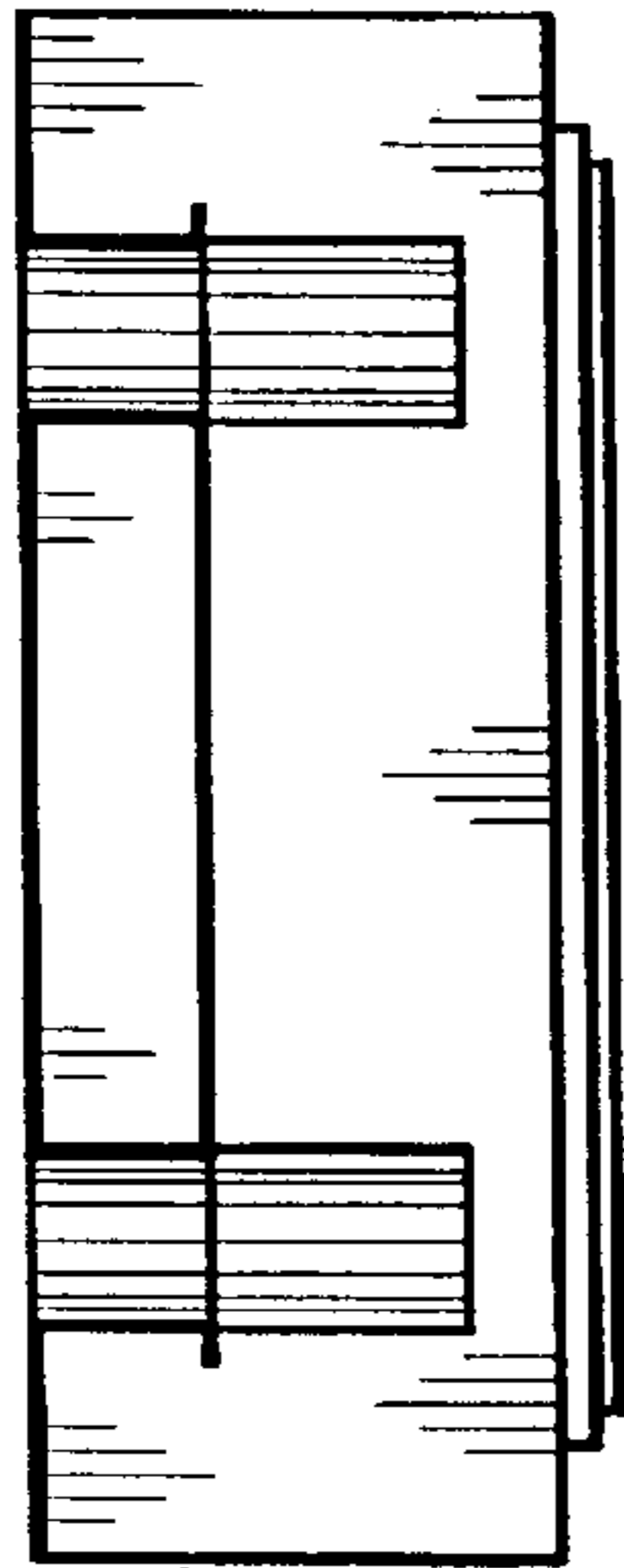

Fig. 2

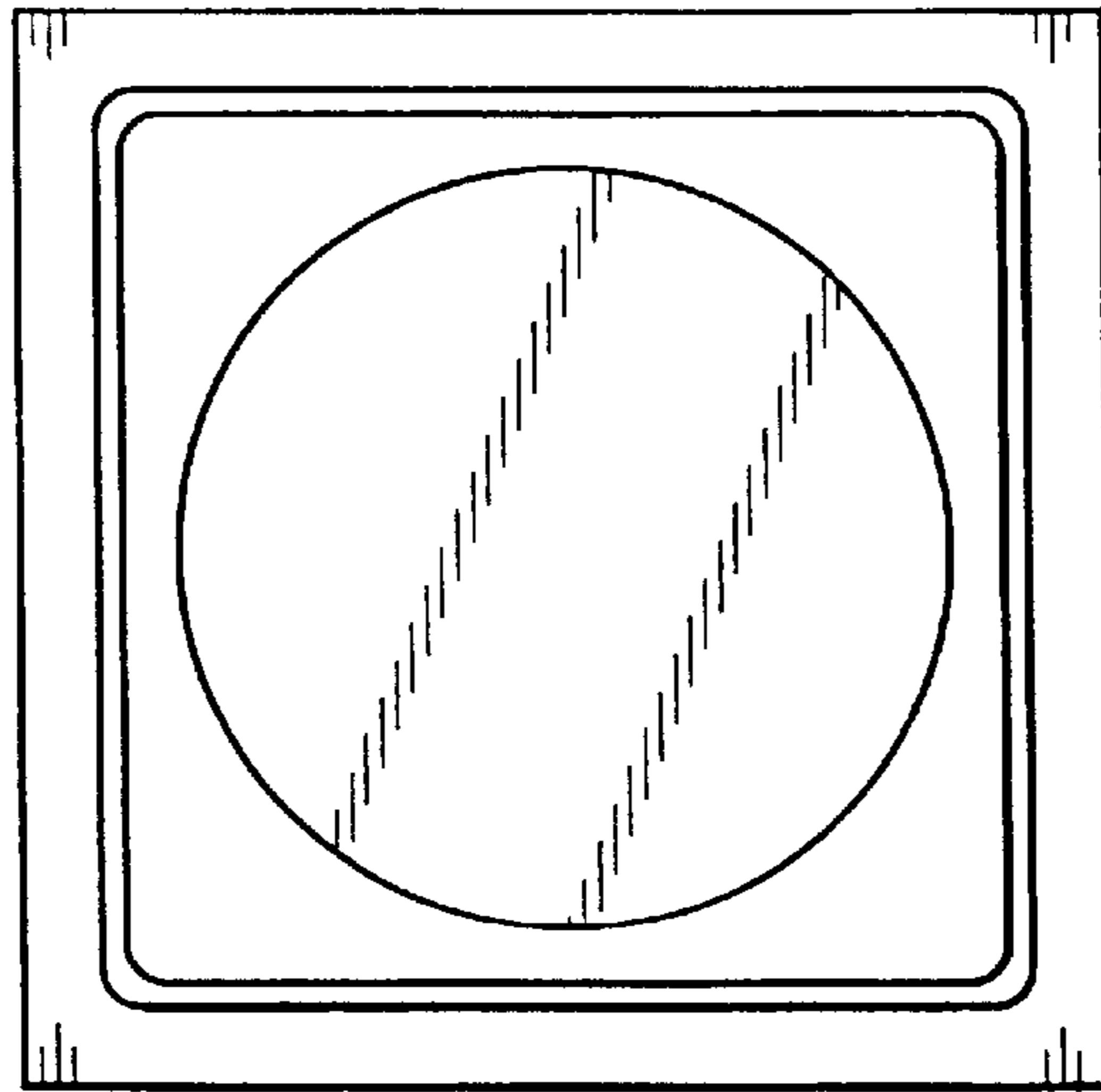

Fig. 3

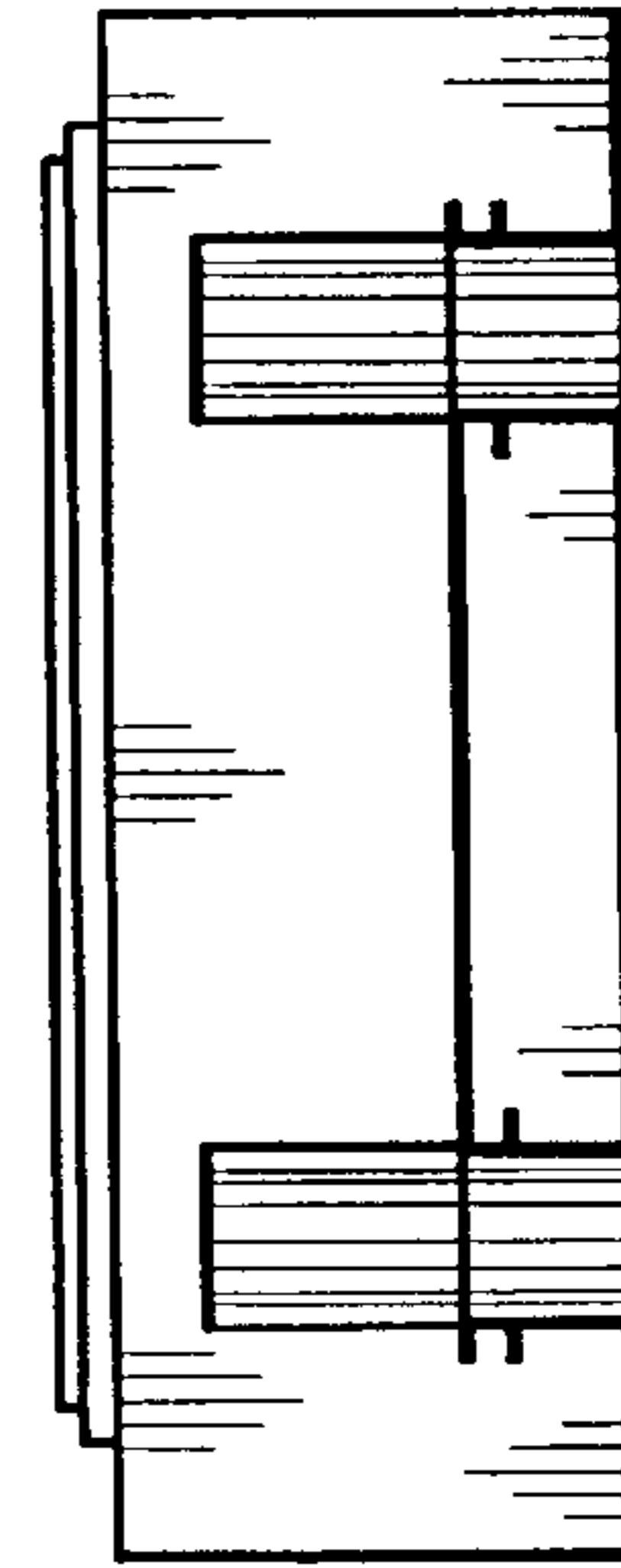

Fig. 4

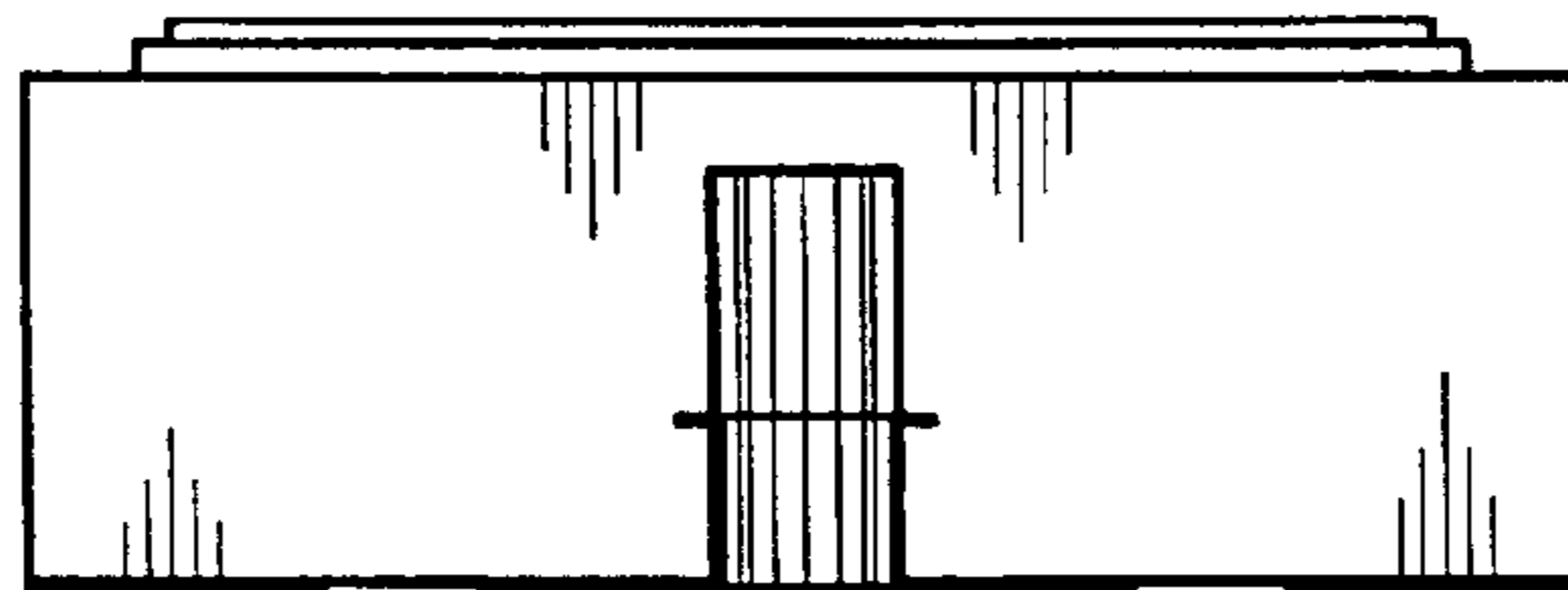

Fig. 5

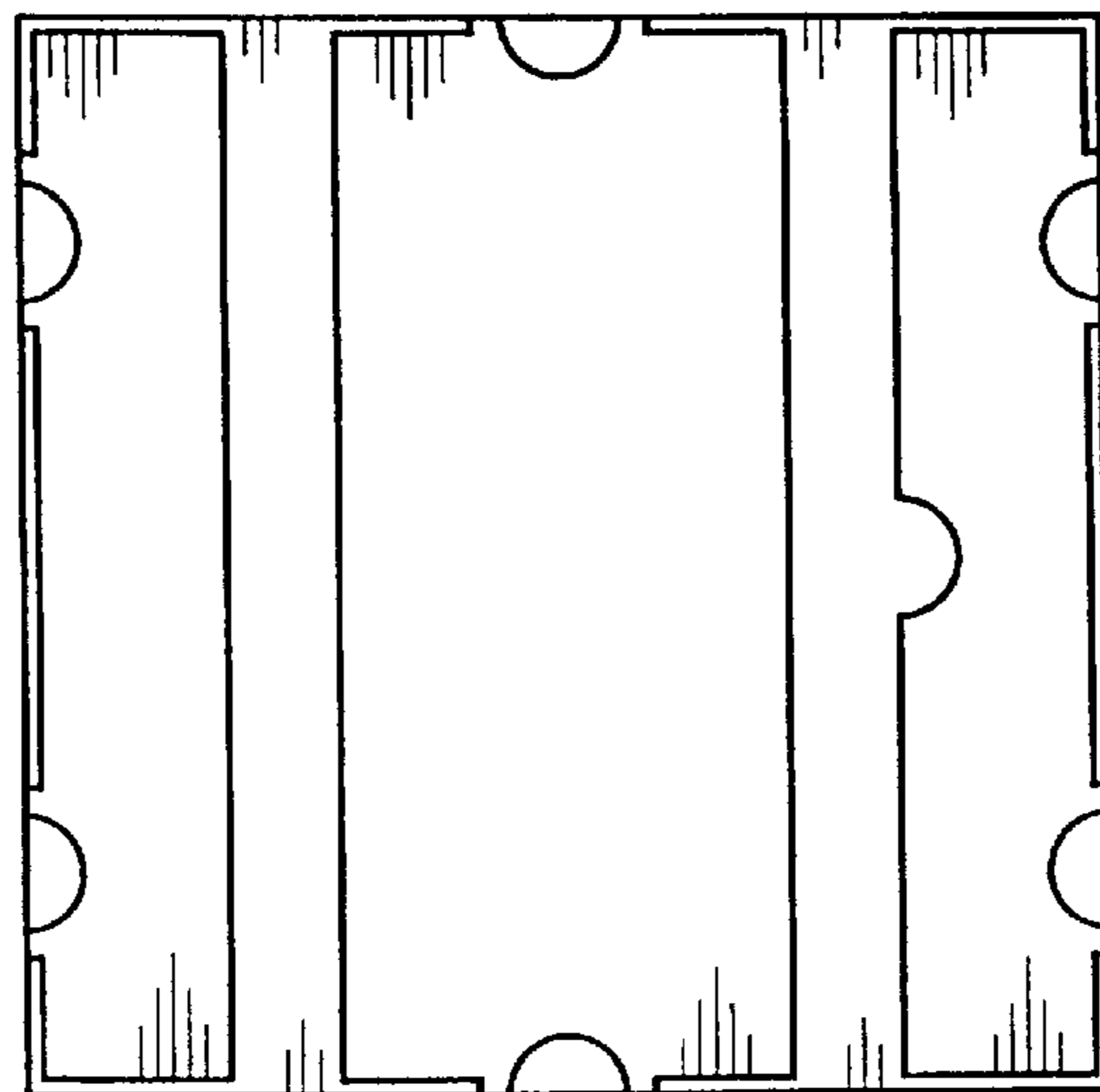

Fig. 6

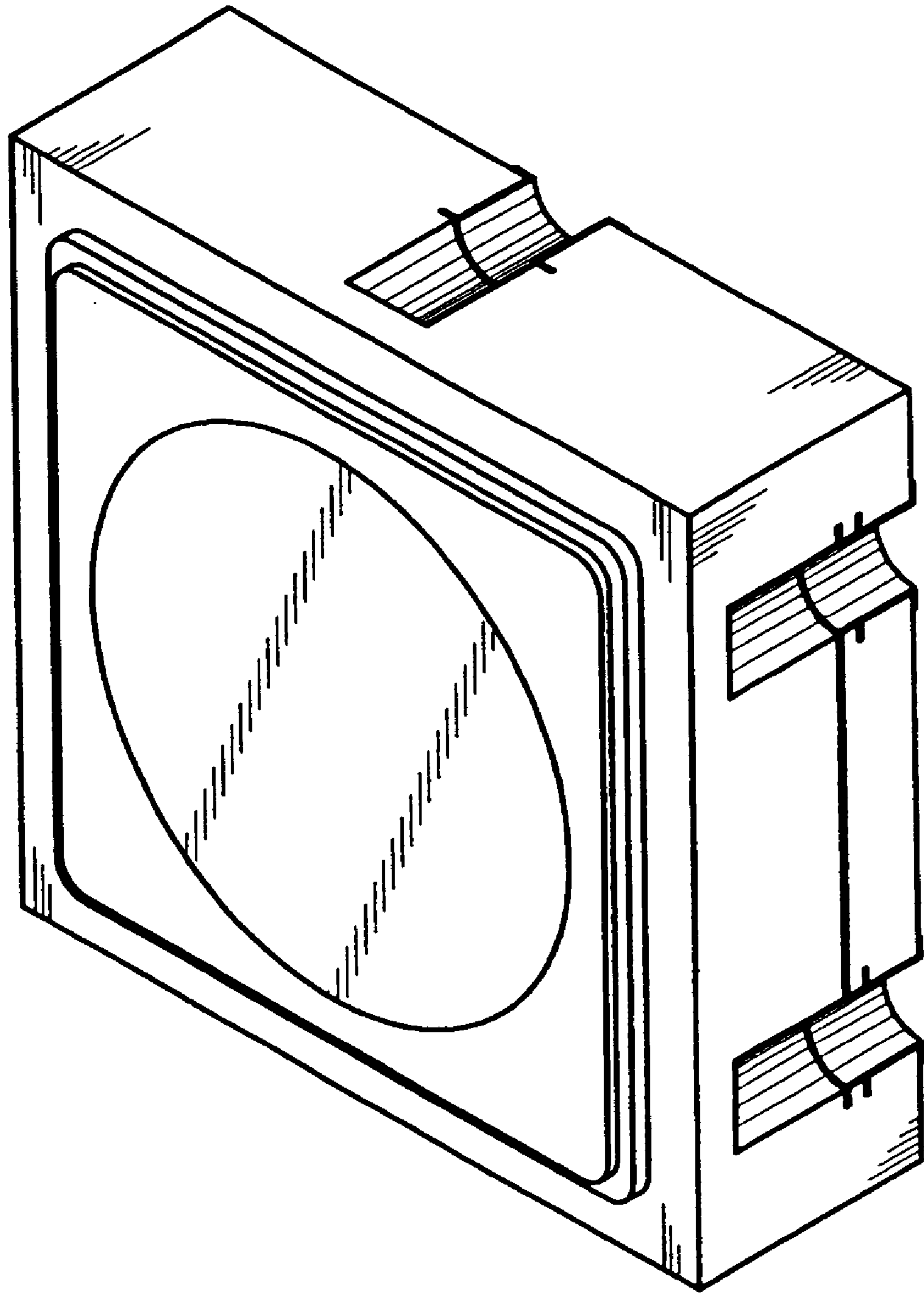

Fig. 7

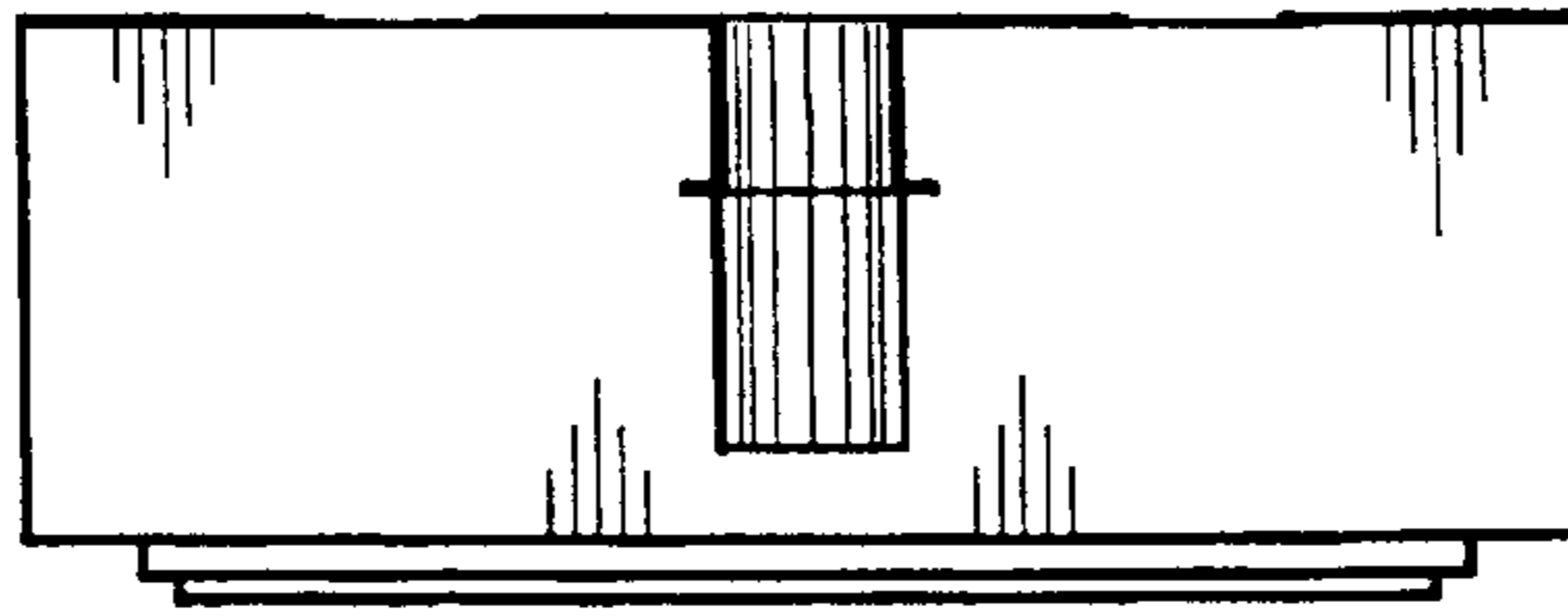

Fig. 8

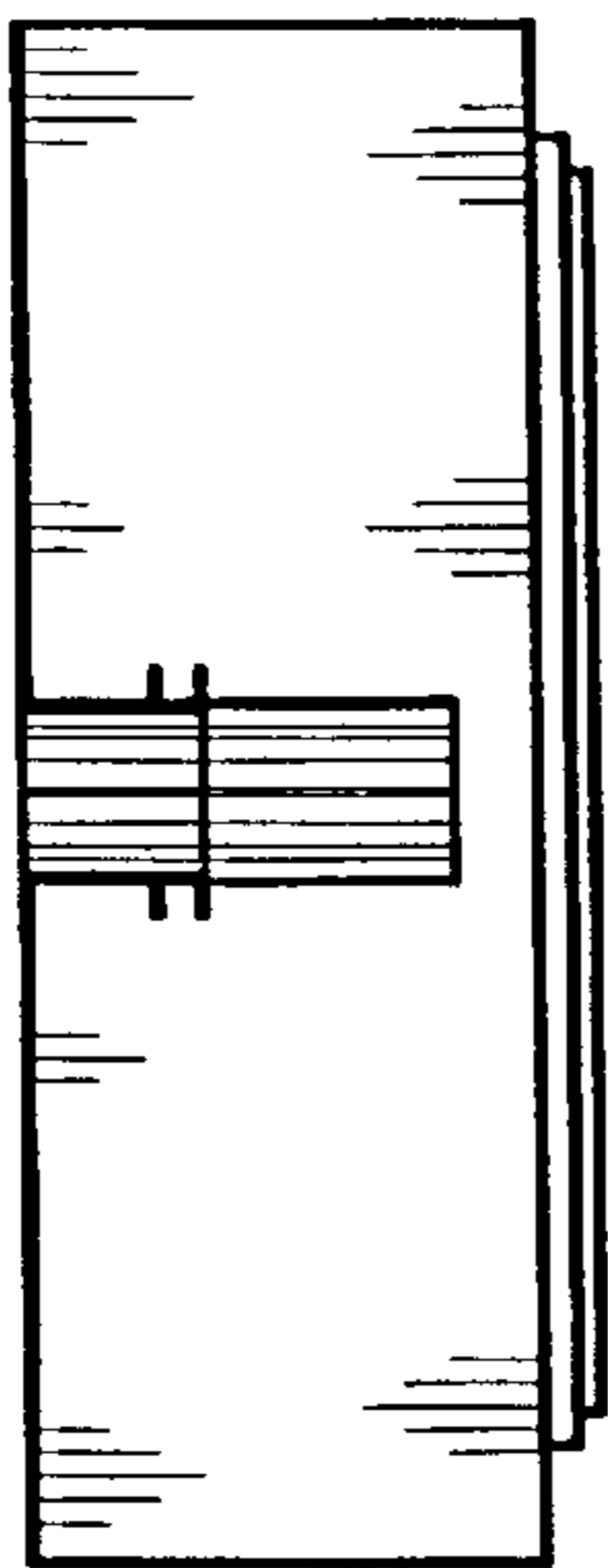

Fig. 9

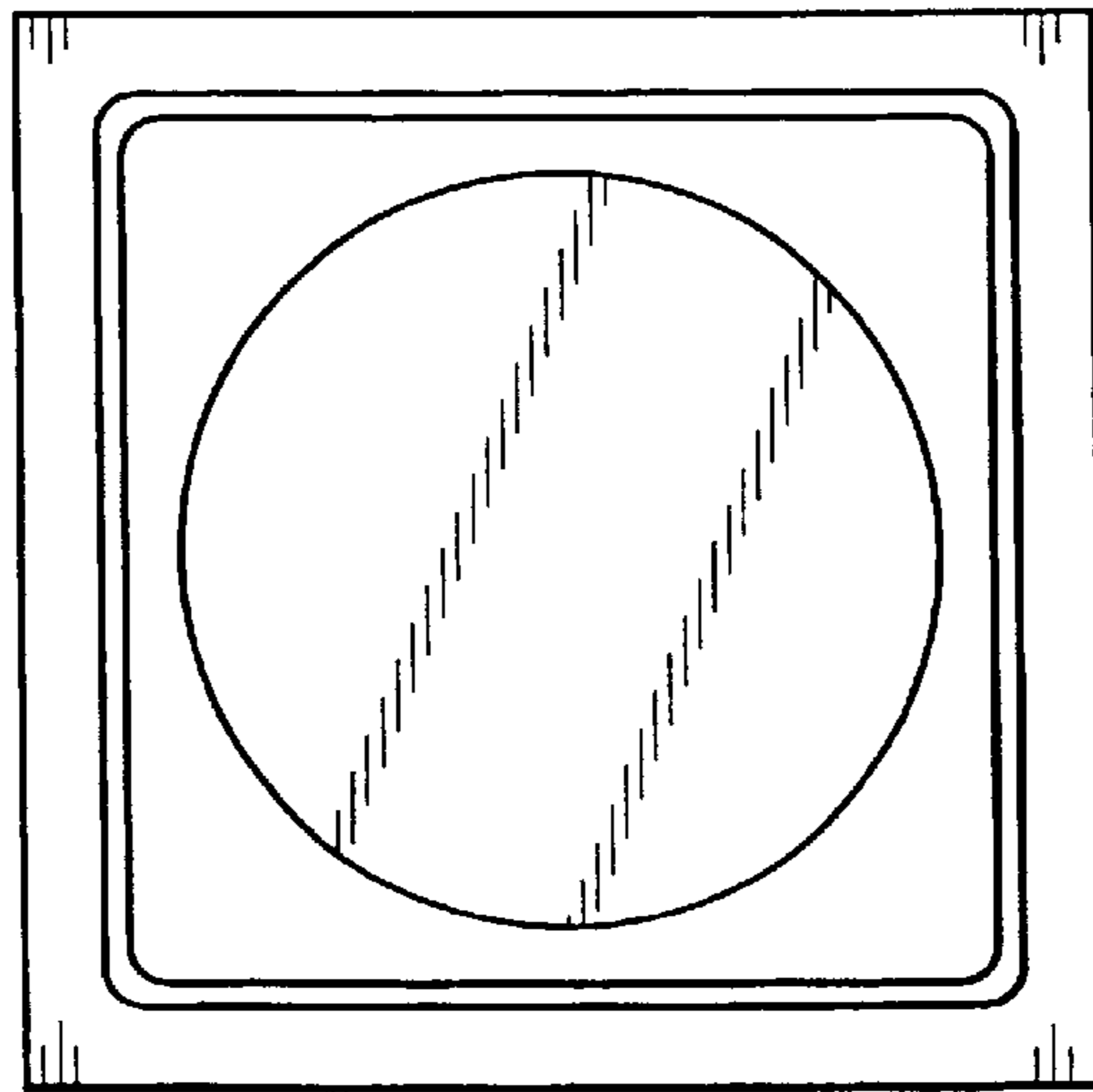

Fig. 10

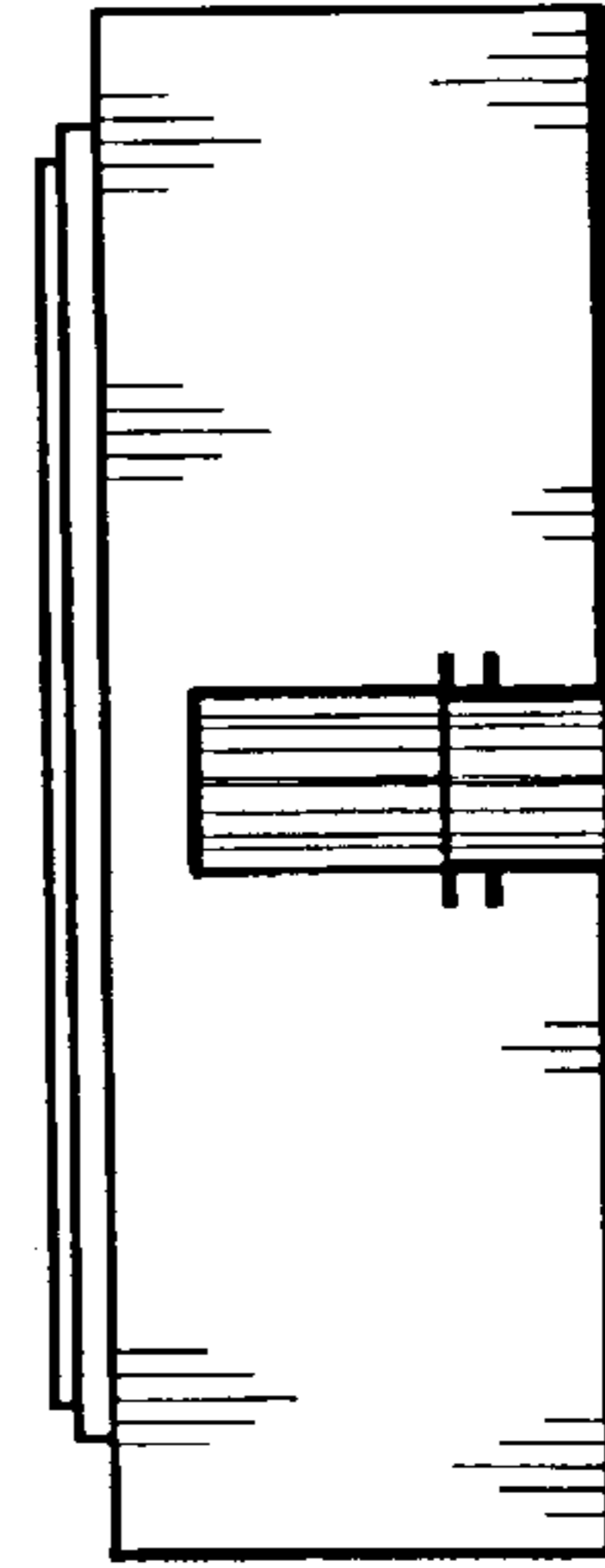

Fig. 11

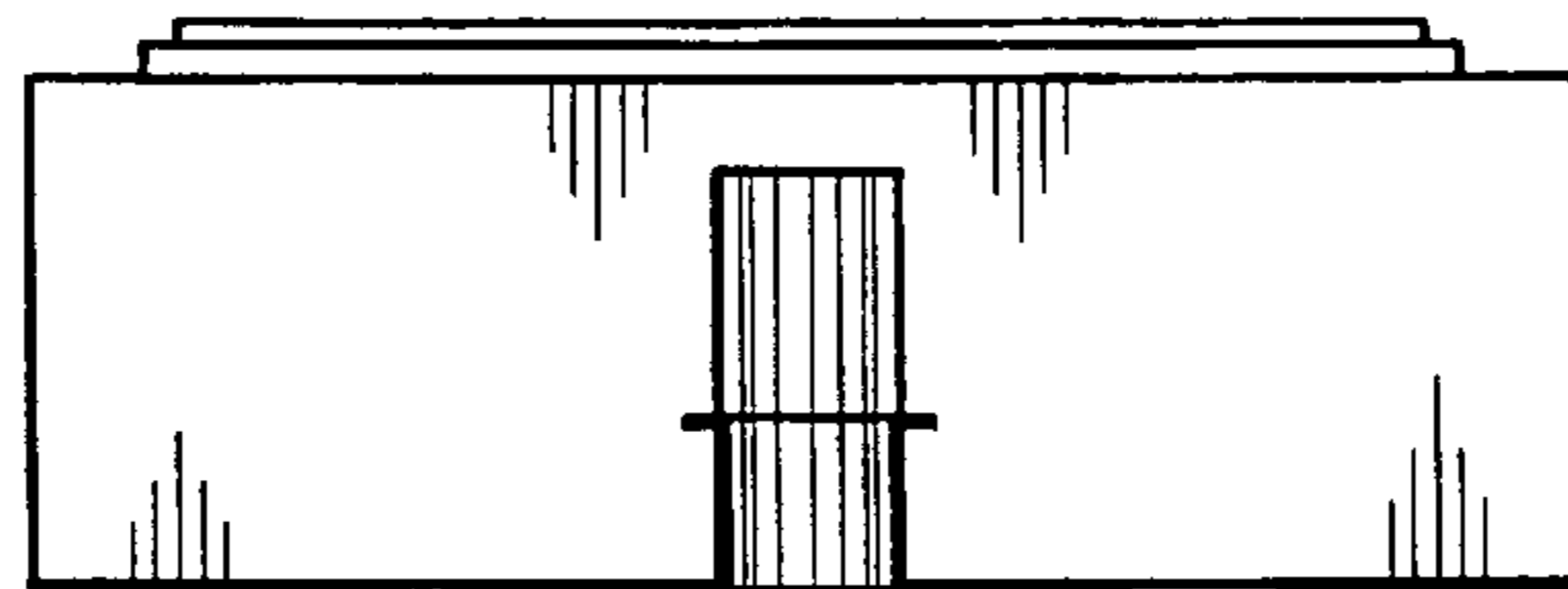

Fig. 12

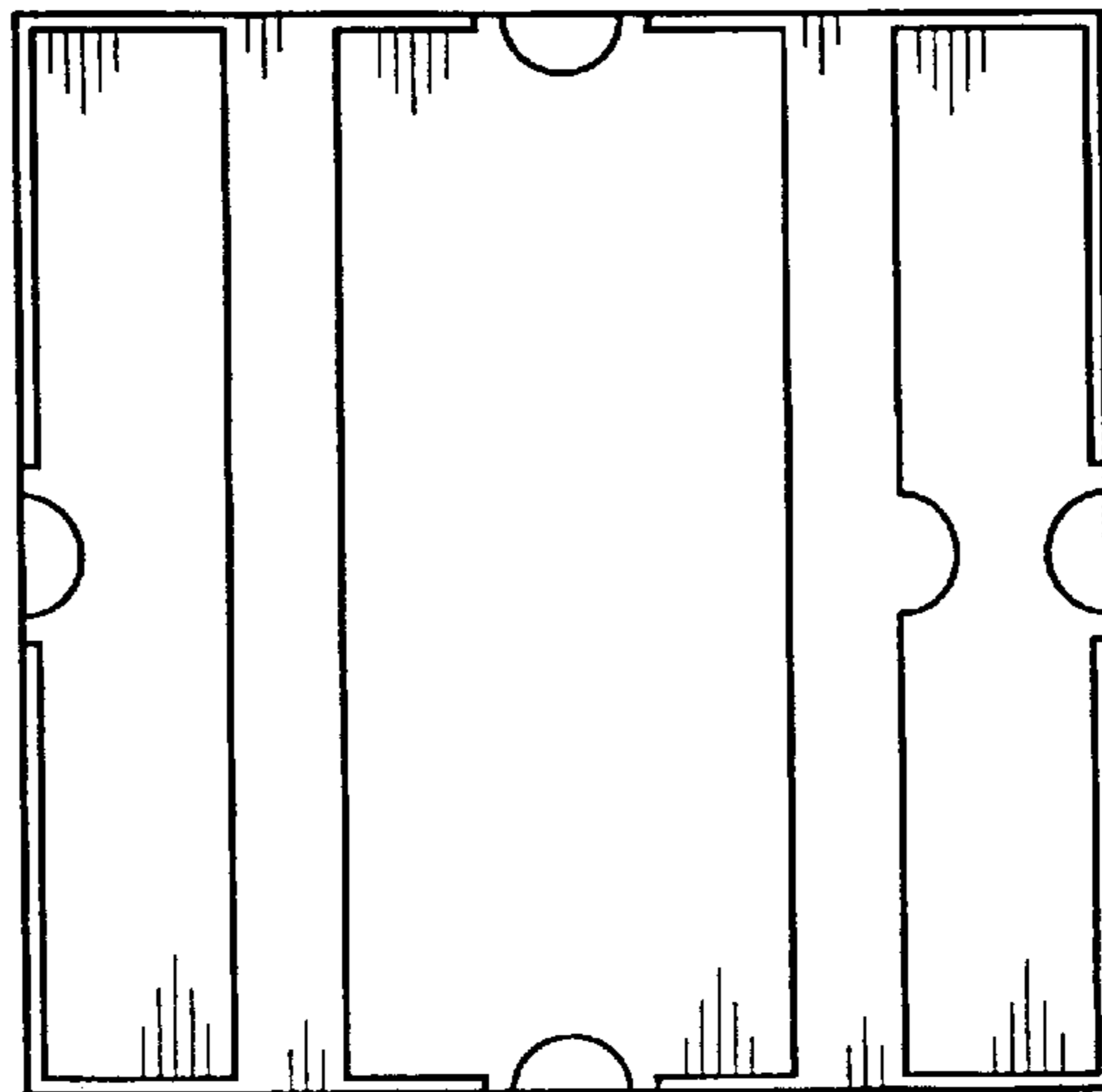

Fig. 13

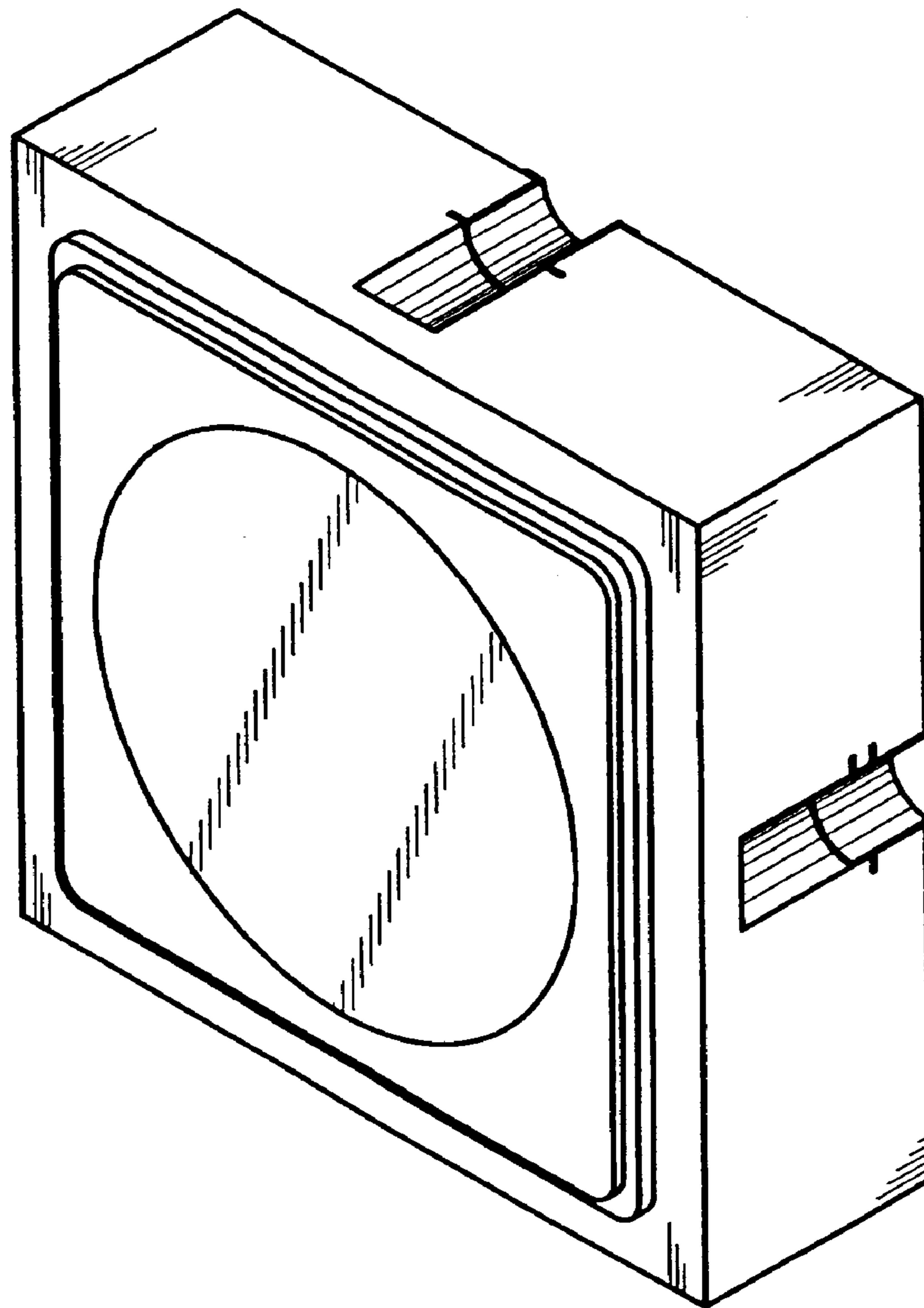

Fig. 14

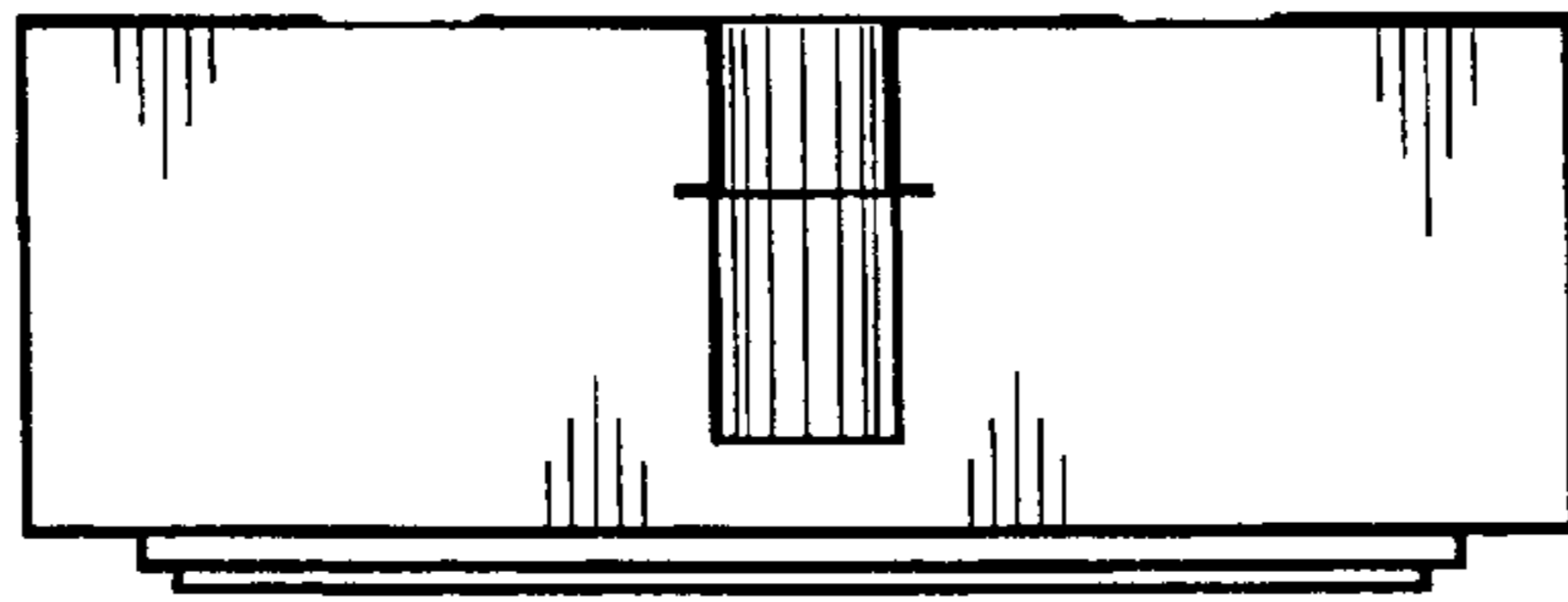

Fig. 15

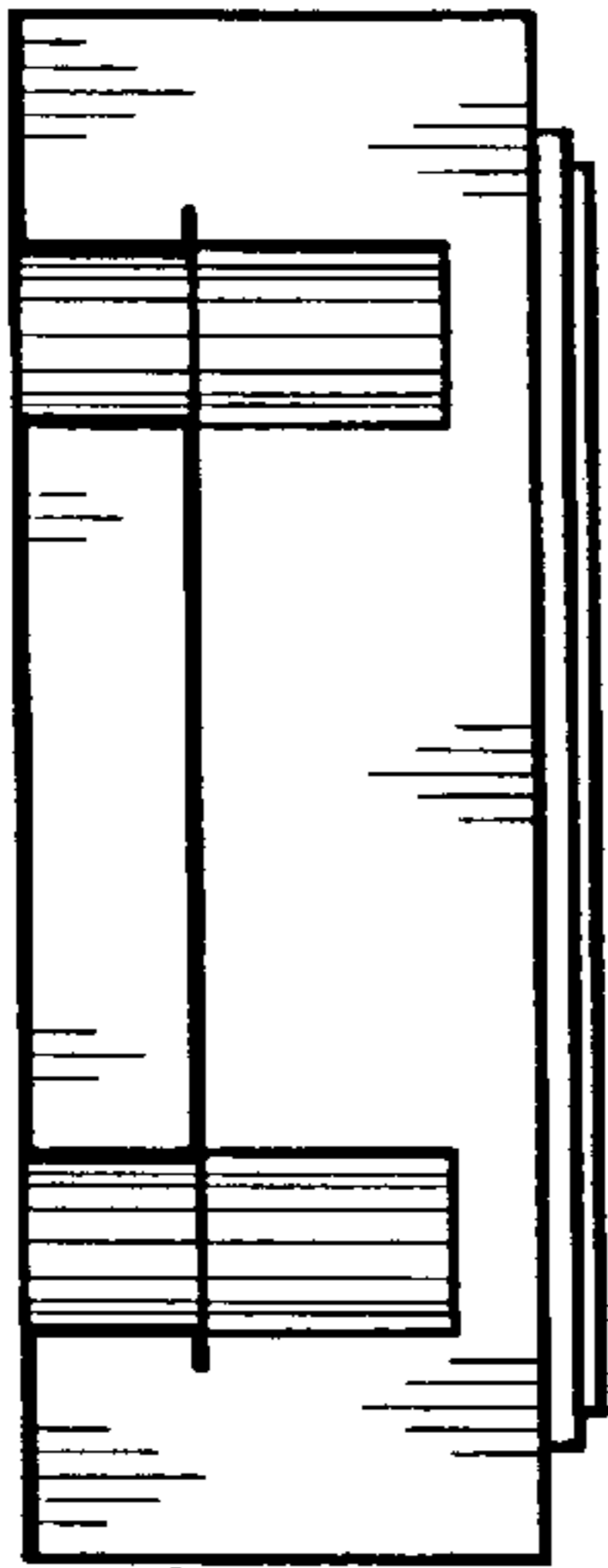

Fig. 16

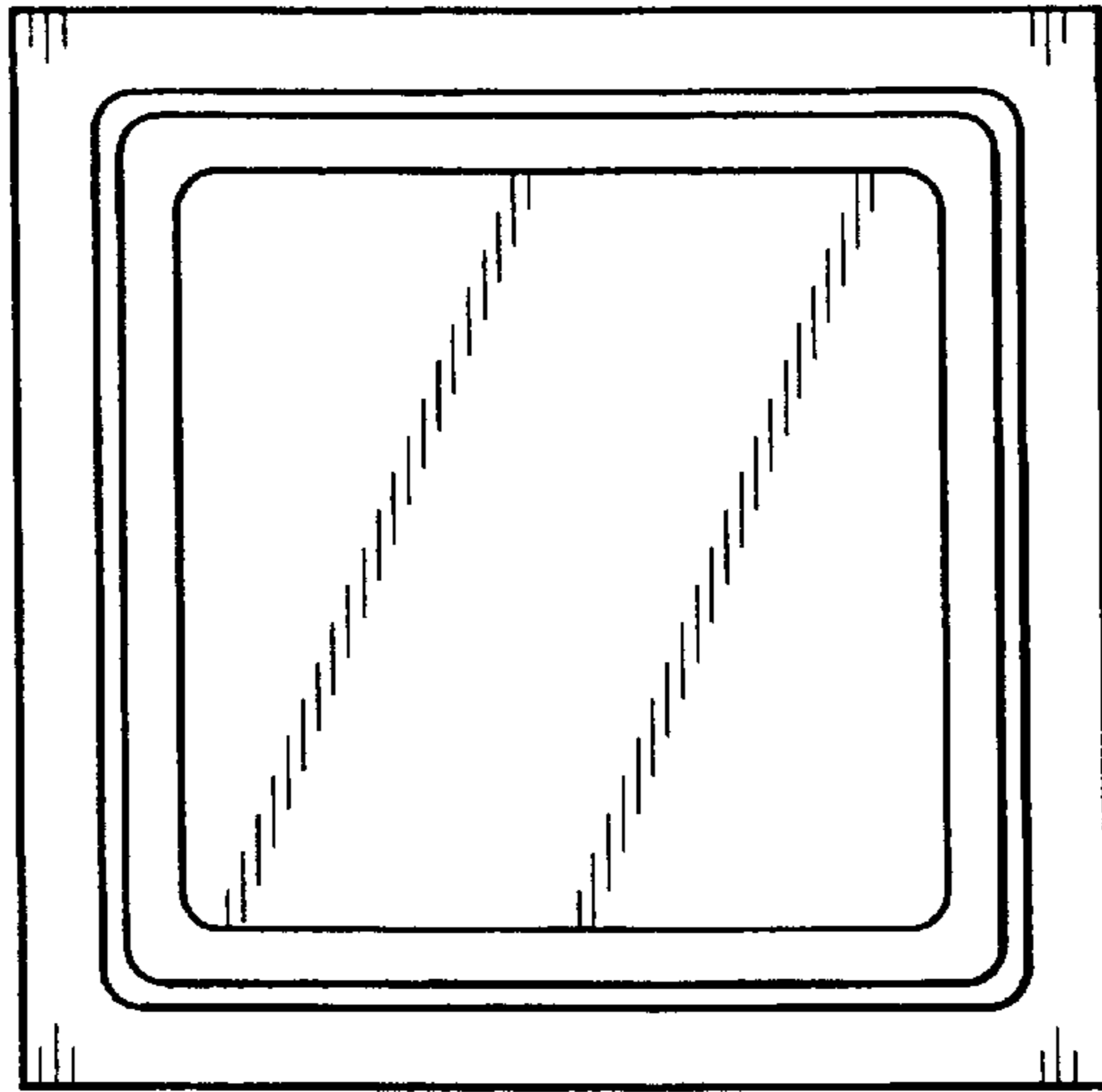

Fig. 17

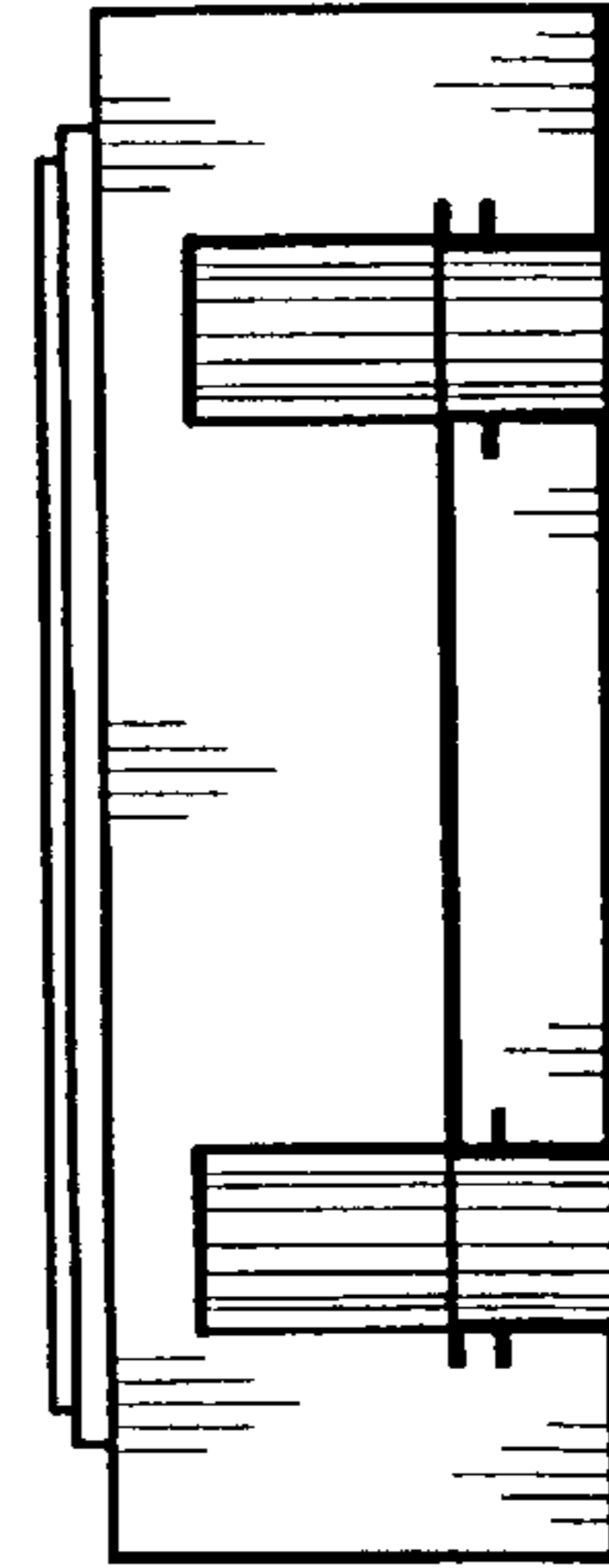

Fig. 18

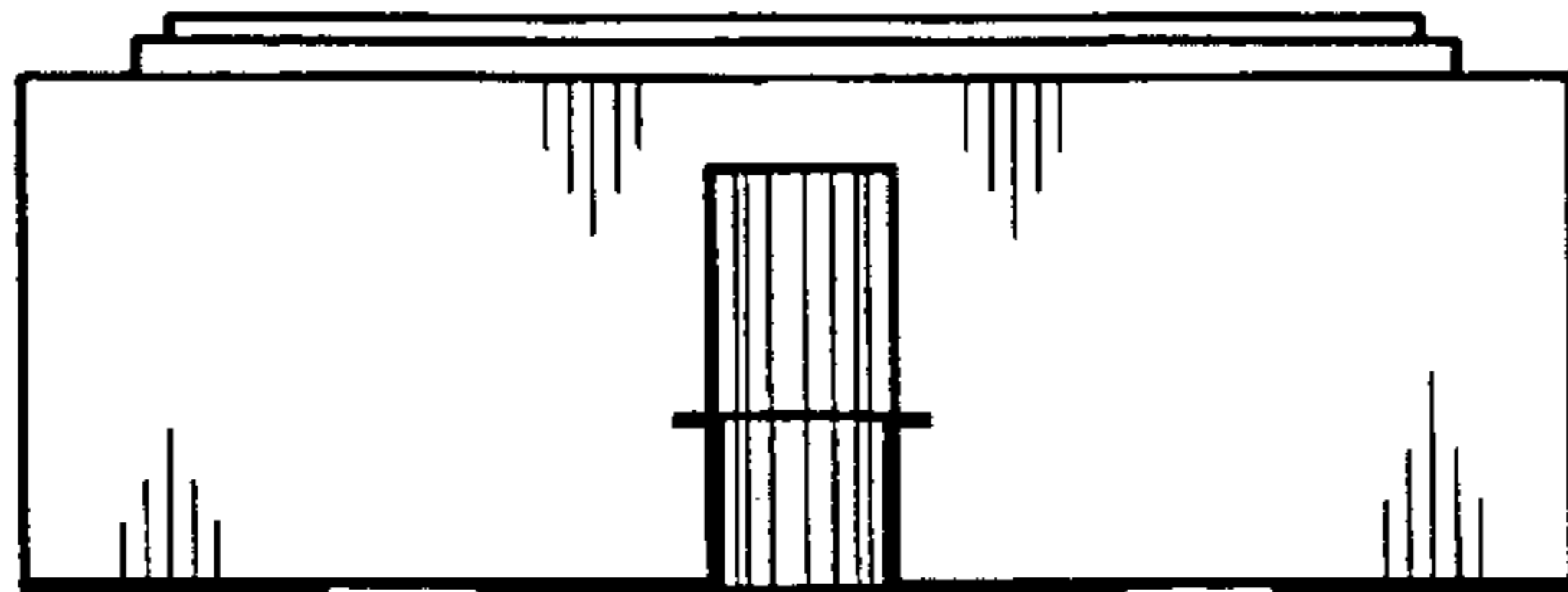

Fig. 19

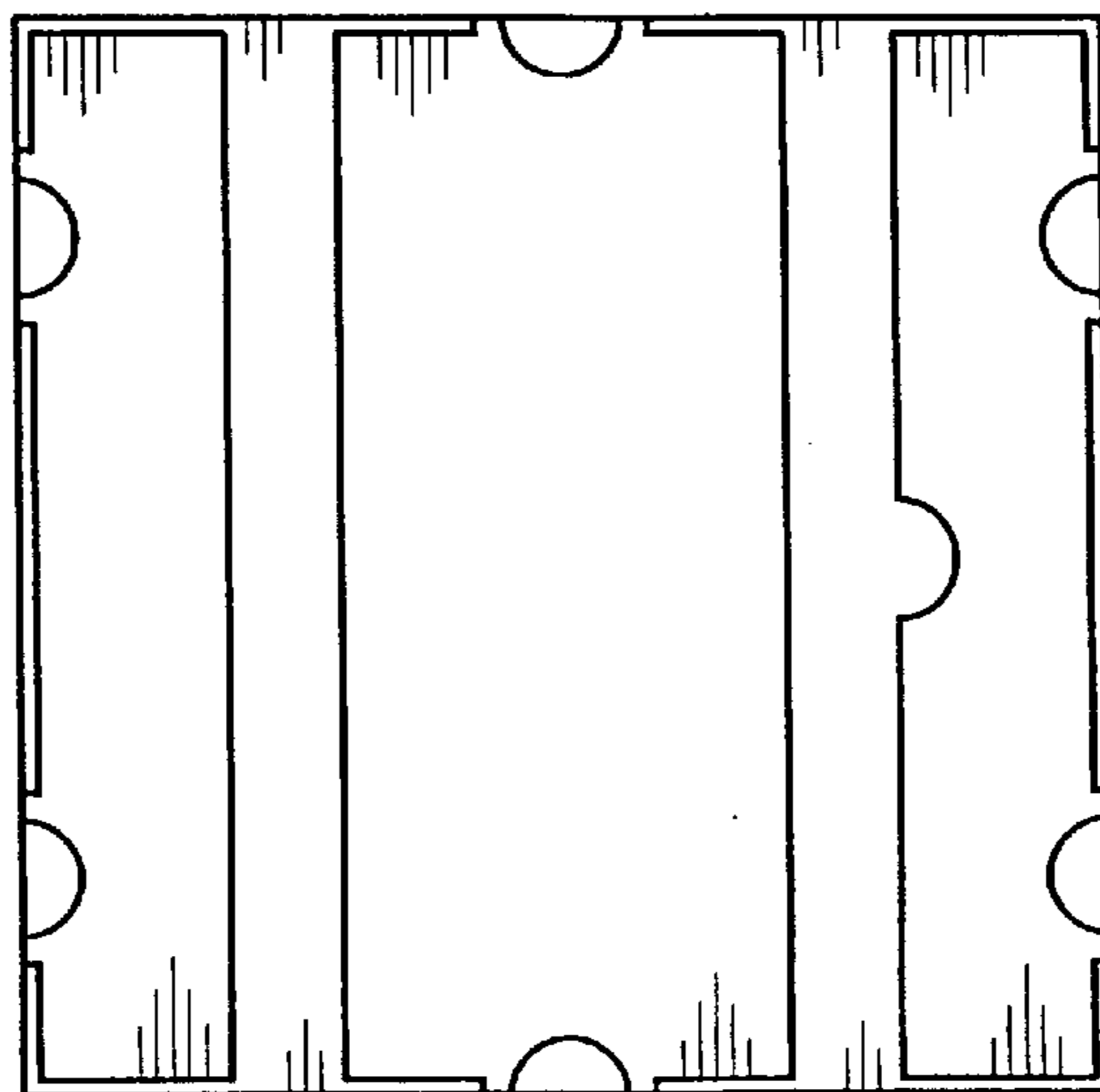

Fig. 20

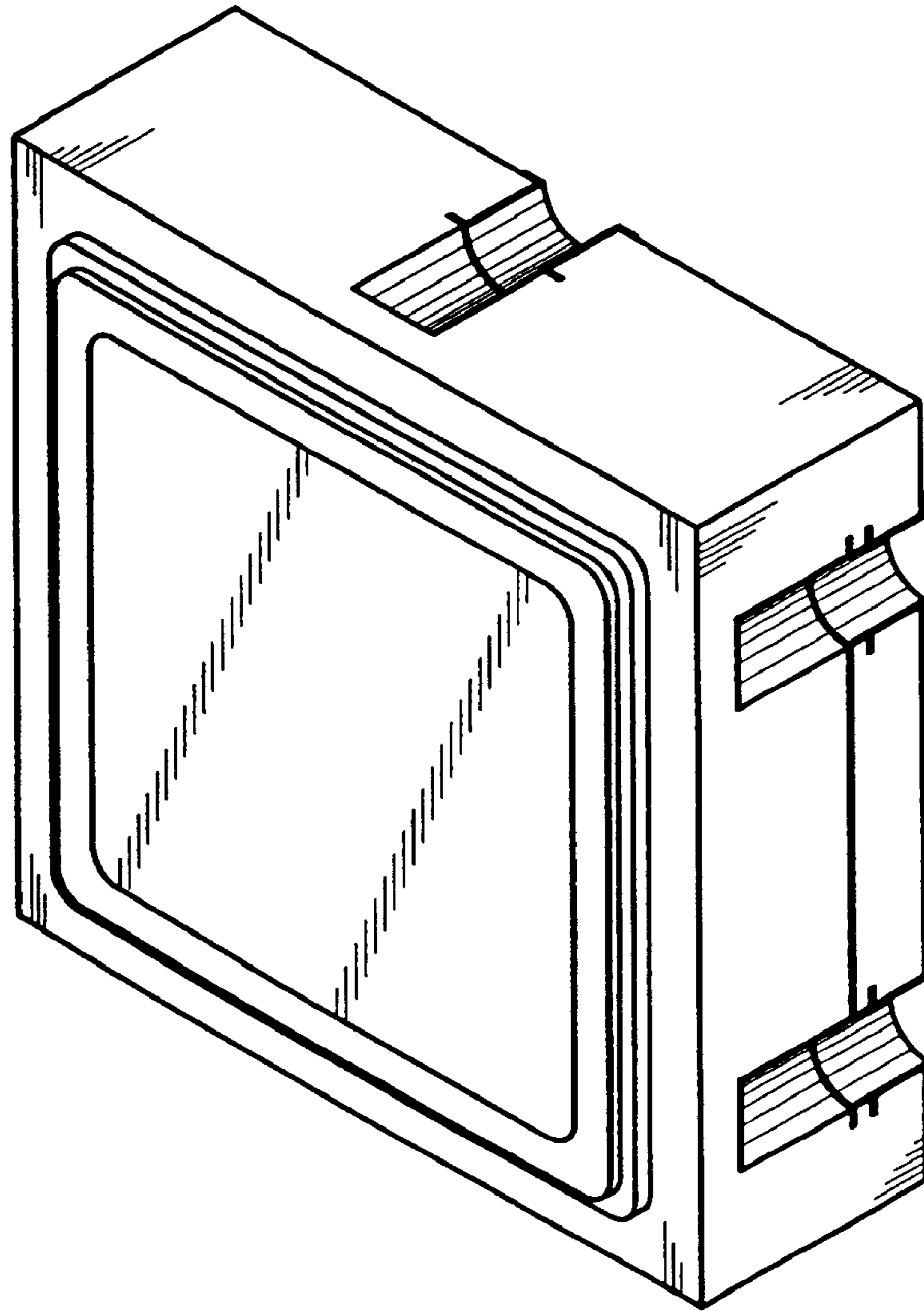

Fig. 21

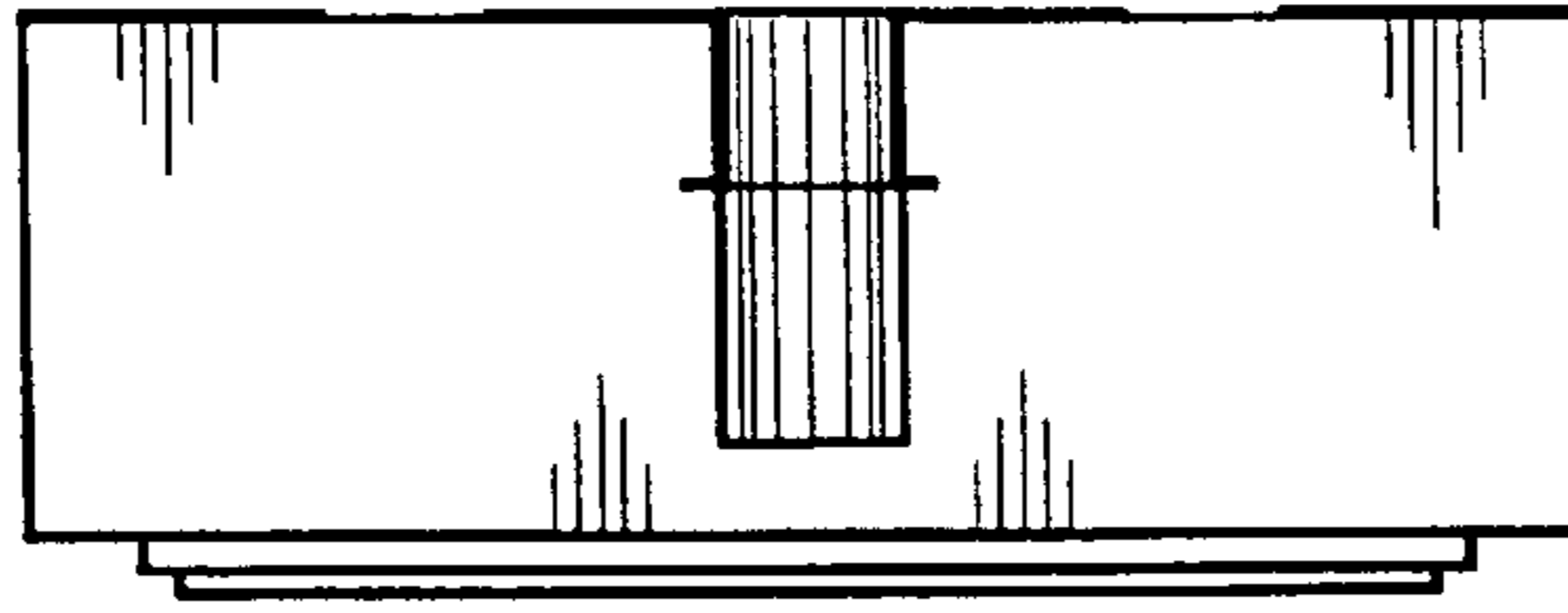

Fig. 22

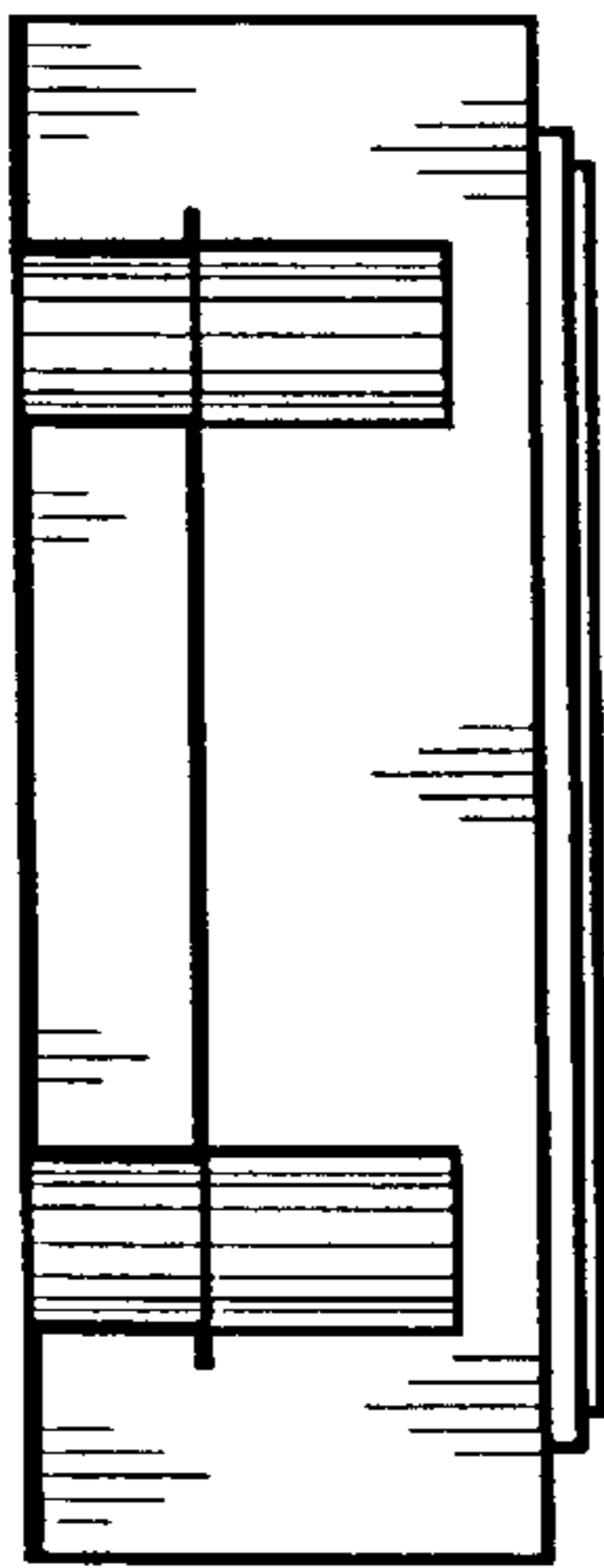

Fig. 23

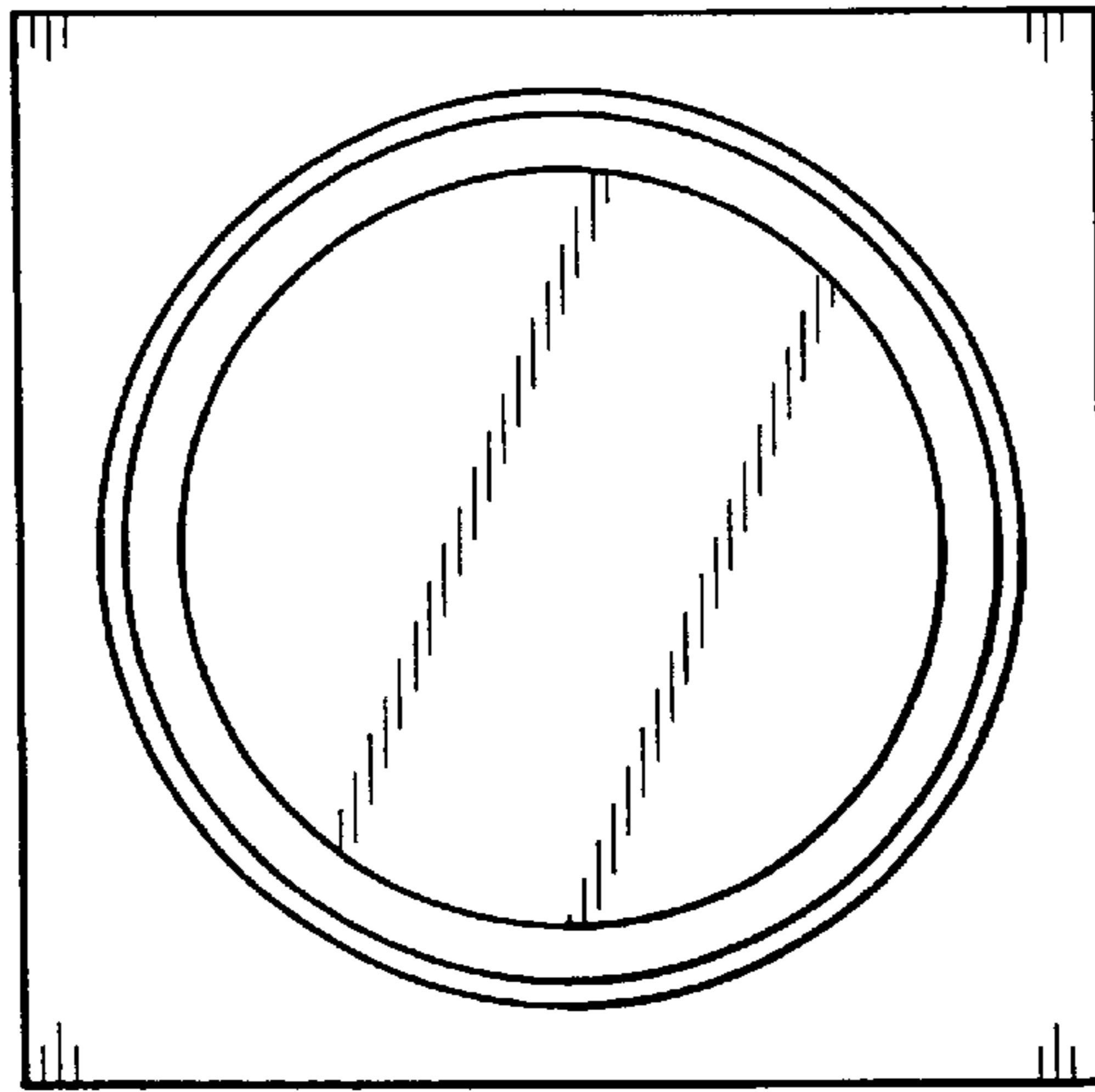

Fig. 24

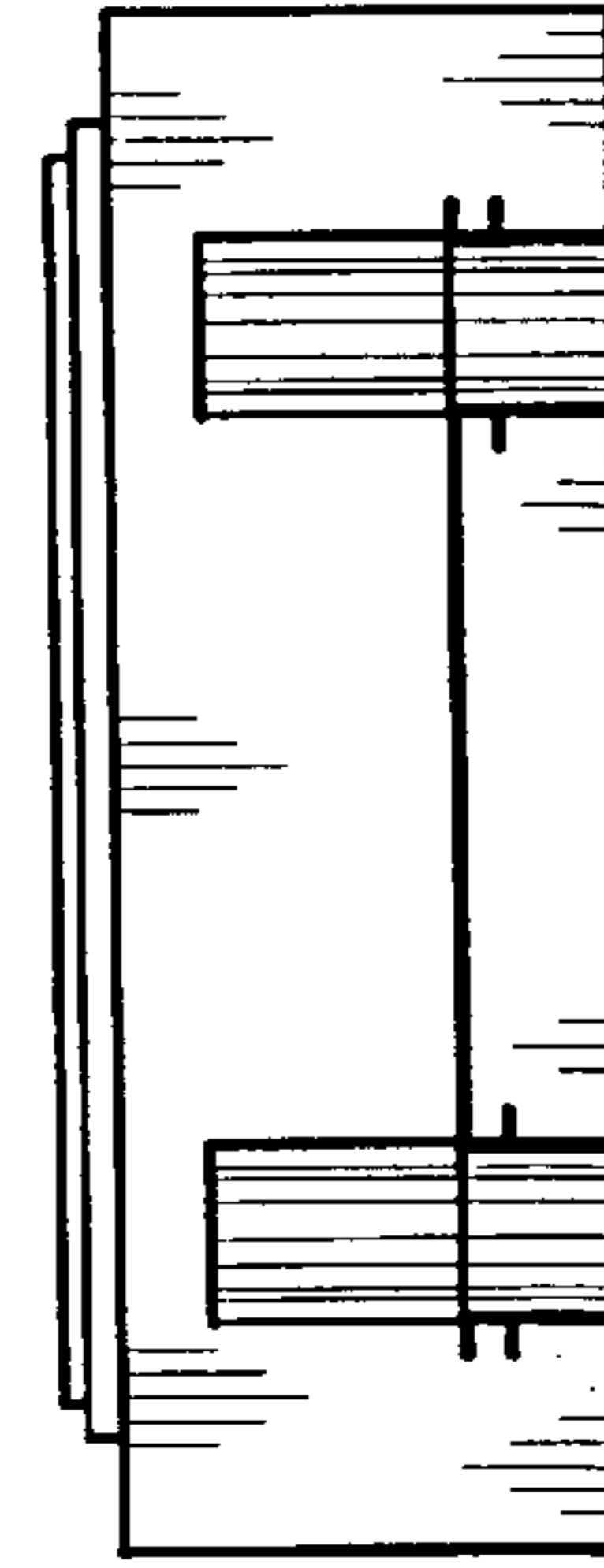

Fig. 25

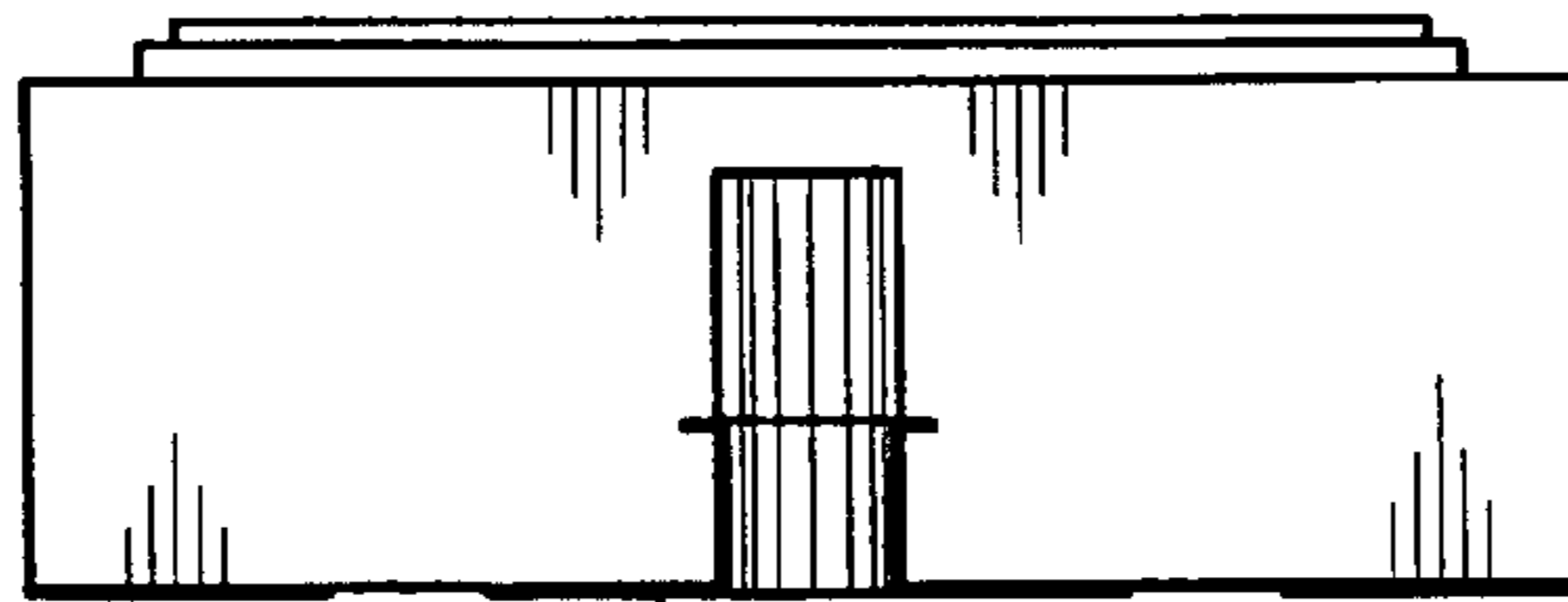

Fig. 26

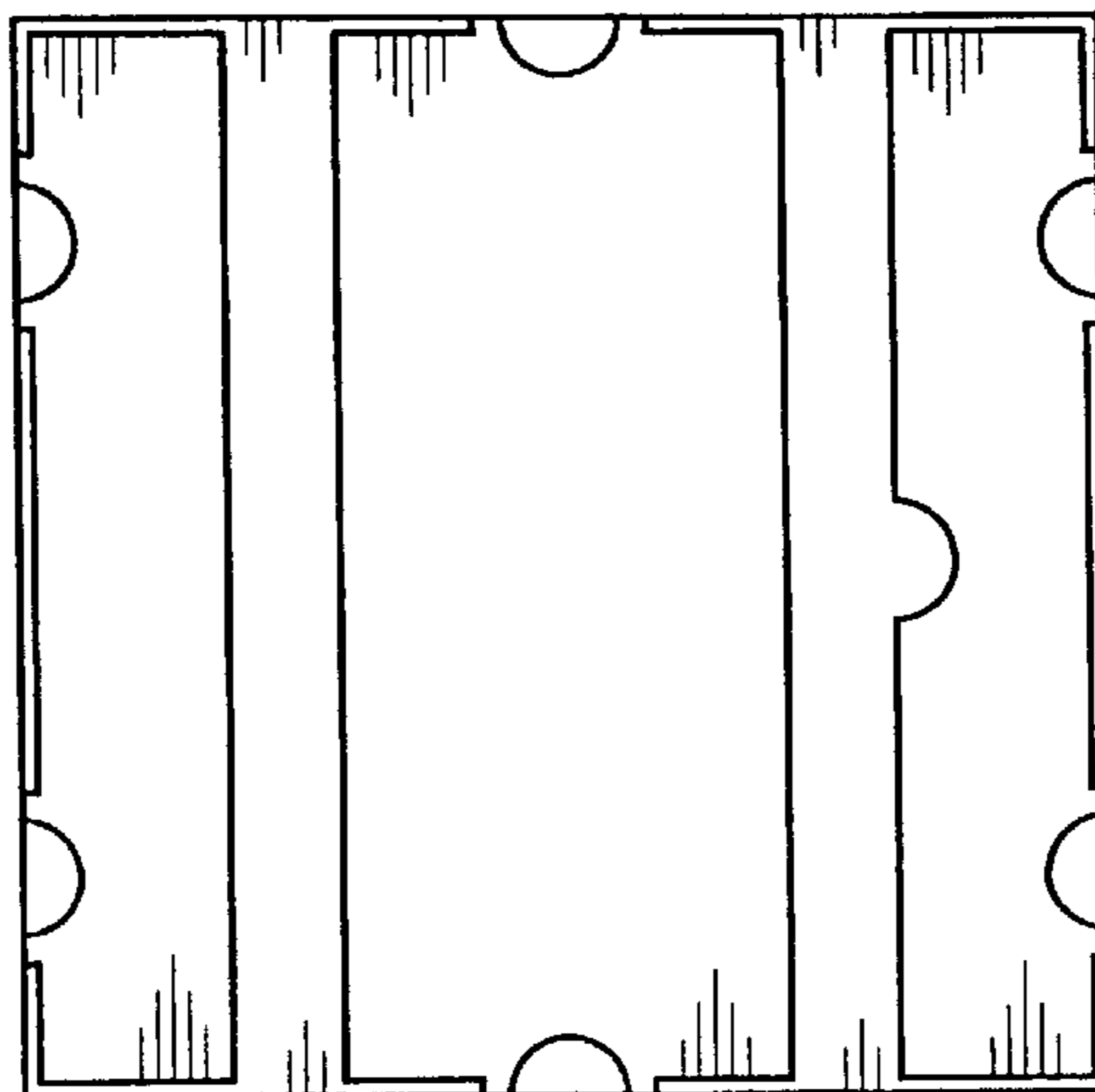

Fig. 27

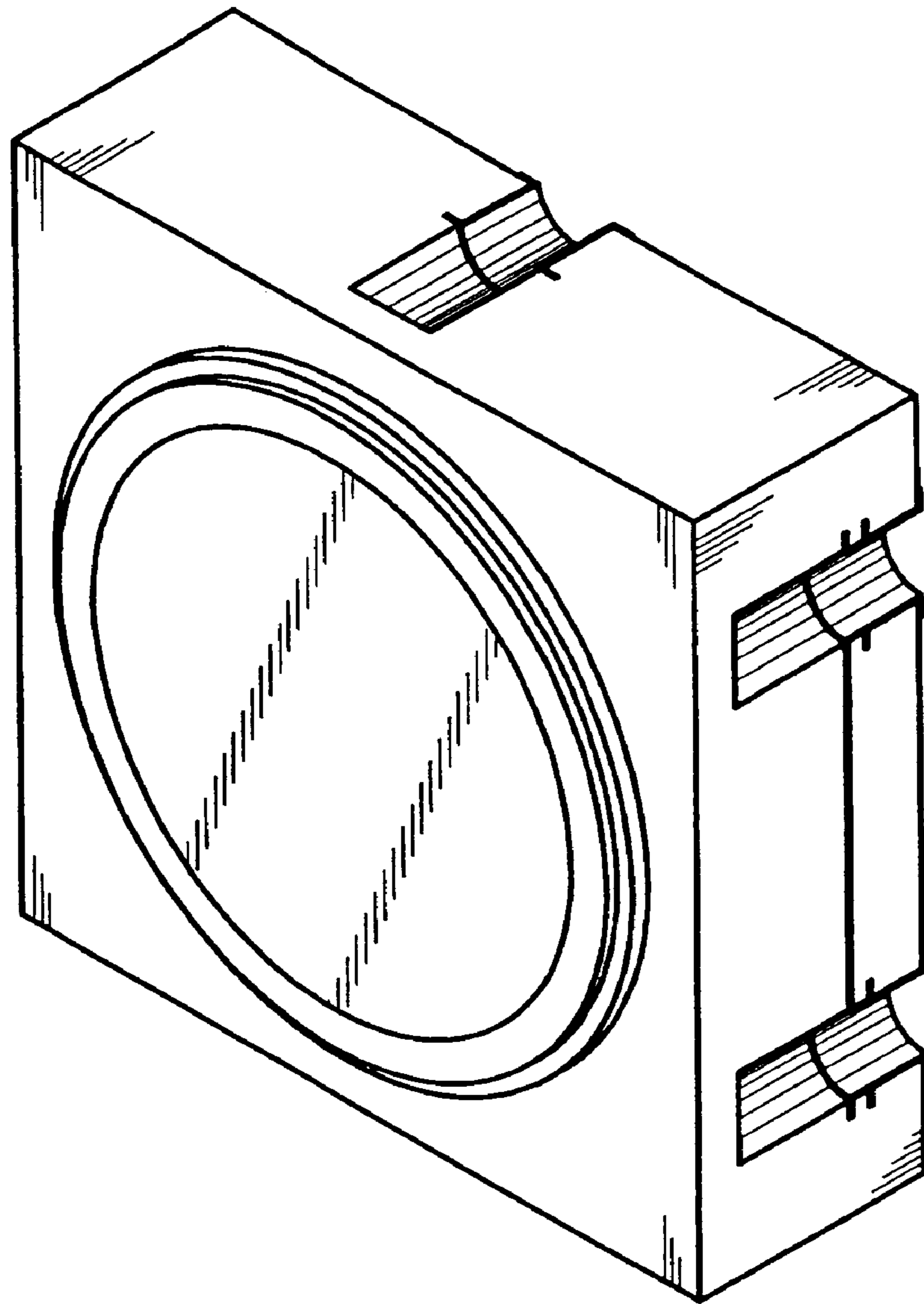

Fig. 28