

US00D508015S

(12) **United States Design Patent**
Badillo

(10) **Patent No.:** **US D508,015 S**

(45) **Date of Patent:** **** Aug. 2, 2005**

(54) **MULTI-PURPOSE STORAGE RACK FOR A SPORT UTILITY VEHICLE**

6,581,813 B2 * 6/2003 Bove et al. 224/324
D477,562 S * 7/2003 McCoy et al. D12/406
D481,003 S * 10/2003 Bauer et al. D12/412

(75) Inventor: **Paul Badillo**, Littleton, CO (US)

* cited by examiner

(73) Assignee: **Intelligent Designs 2000 Corp.**,
Denver, CO (US)

Primary Examiner—Stacia Cadmus

(74) *Attorney, Agent, or Firm*—Sheridan Ross P.C.

(**) Term: **14 Years**

(57) **CLAIM**

(21) Appl. No.: **29/177,928**

The ornamental design for a multi-purpose storage rack for a sport utility vehicle, as shown and described.

(22) Filed: **Mar. 17, 2003**

DESCRIPTION

(51) **LOC (8) Cl.** **12-16**

(52) **U.S. Cl.** **D12/412**

(58) **Field of Search** D12/406, 412,
D12/414, 414.1; 293/37.1, 3, 100; 224/309–310,
315–316, 323–329, 400; D6/552; D3/304–306;
280/760–762, 848, 727, 769

FIG. 1 is a top plan view of a multi-purpose storage rack for a sport utility vehicle;

FIG. 2 is a left elevation view of the invention illustrated in FIG. 1;

FIG. 3 is a right elevation view of the invention illustrated in FIG. 1;

FIG. 4 is a front elevation view of the invention illustrated in FIG. 1;

FIG. 5 is a perspective view of the invention illustrated in FIG. 1, the broken lines showing environment for illustrative purposes only and forming no part of the claimed design; and,

FIG. 6 is a perspective view of a second embodiment of the multi-purpose storage rack for a sport utility vehicle shown in FIG. 1, the only difference being that this configuration includes the addition of mesh in a forward area of the rack.

(56) **References Cited**

U.S. PATENT DOCUMENTS

2,387,779	A	*	10/1945	Strauss	224/325
3,215,323	A	*	11/1965	Bonitt	224/325
D406,557	S	*	3/1999	Bentley	D12/412
D413,562	S	*	9/1999	Van Dusen et al.	D12/412
D422,553	S	*	4/2000	VonDuyke	D12/412
D434,364	S	*	11/2000	Bauer et al.	D12/412
D434,718	S	*	12/2000	Kreisler	D12/412
D435,510	S	*	12/2000	Quidort	D12/412
6,425,508	B1	*	7/2002	Cole et al.	224/325
D470,451	S	*	2/2003	Bushart et al.	D12/412

1 Claim, 3 Drawing Sheets

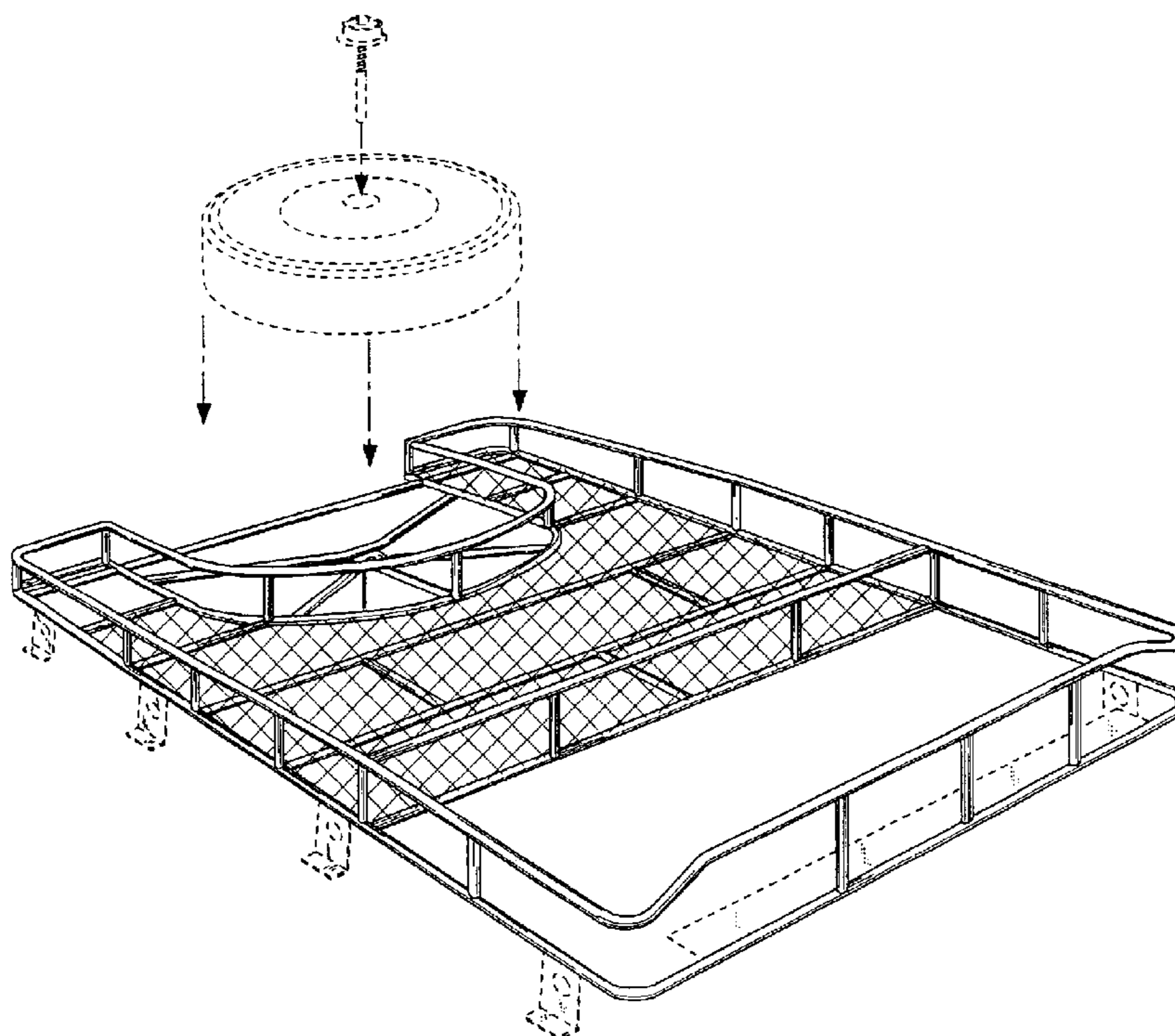

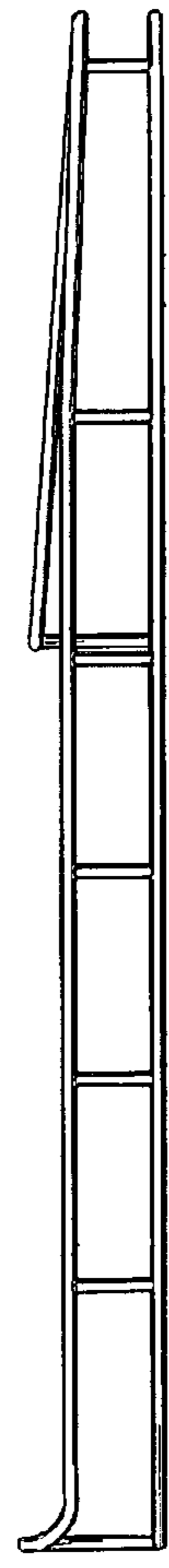
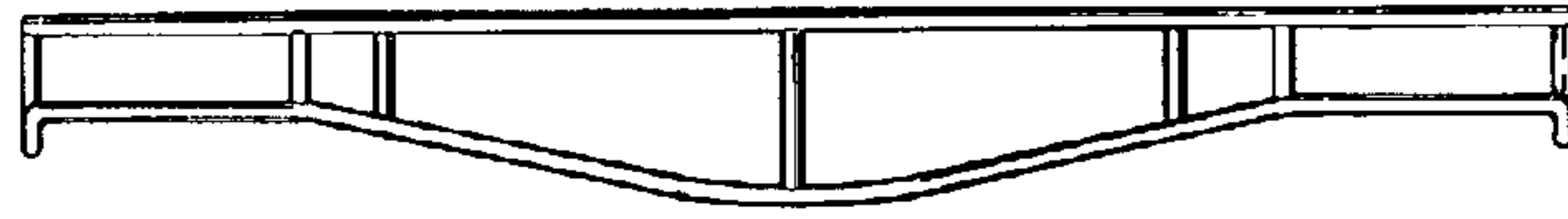
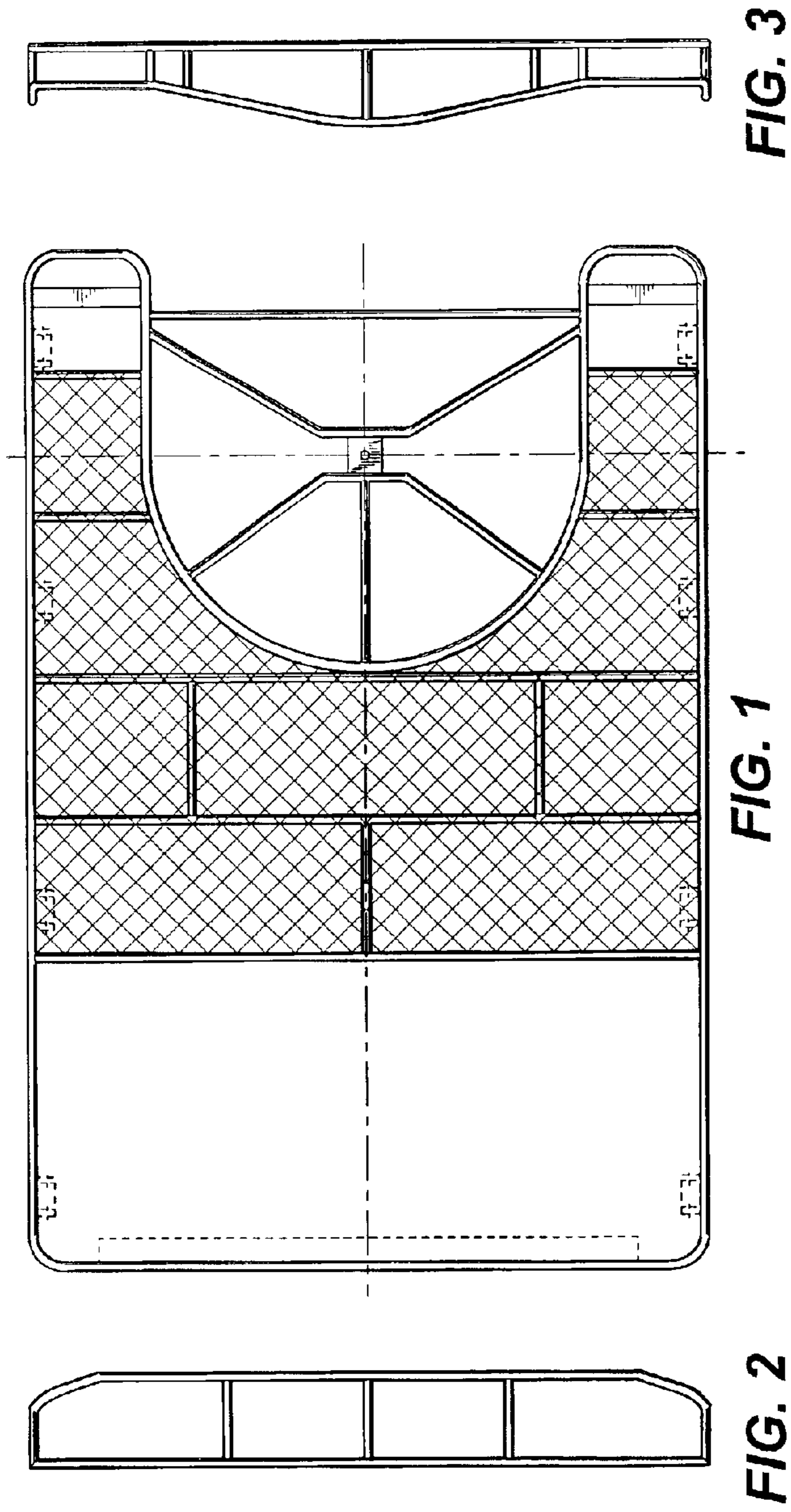

FIG. 4

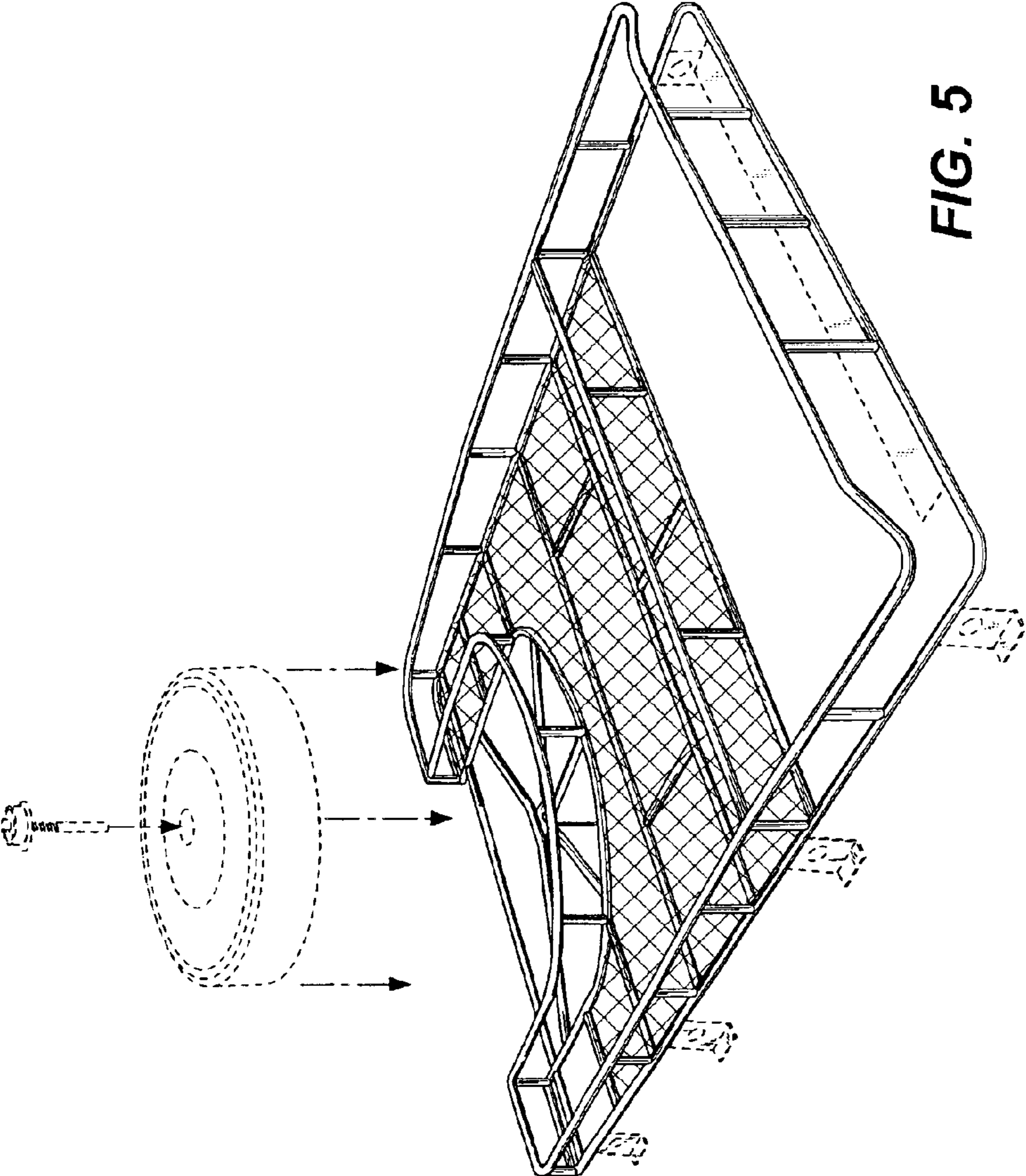

FIG. 5

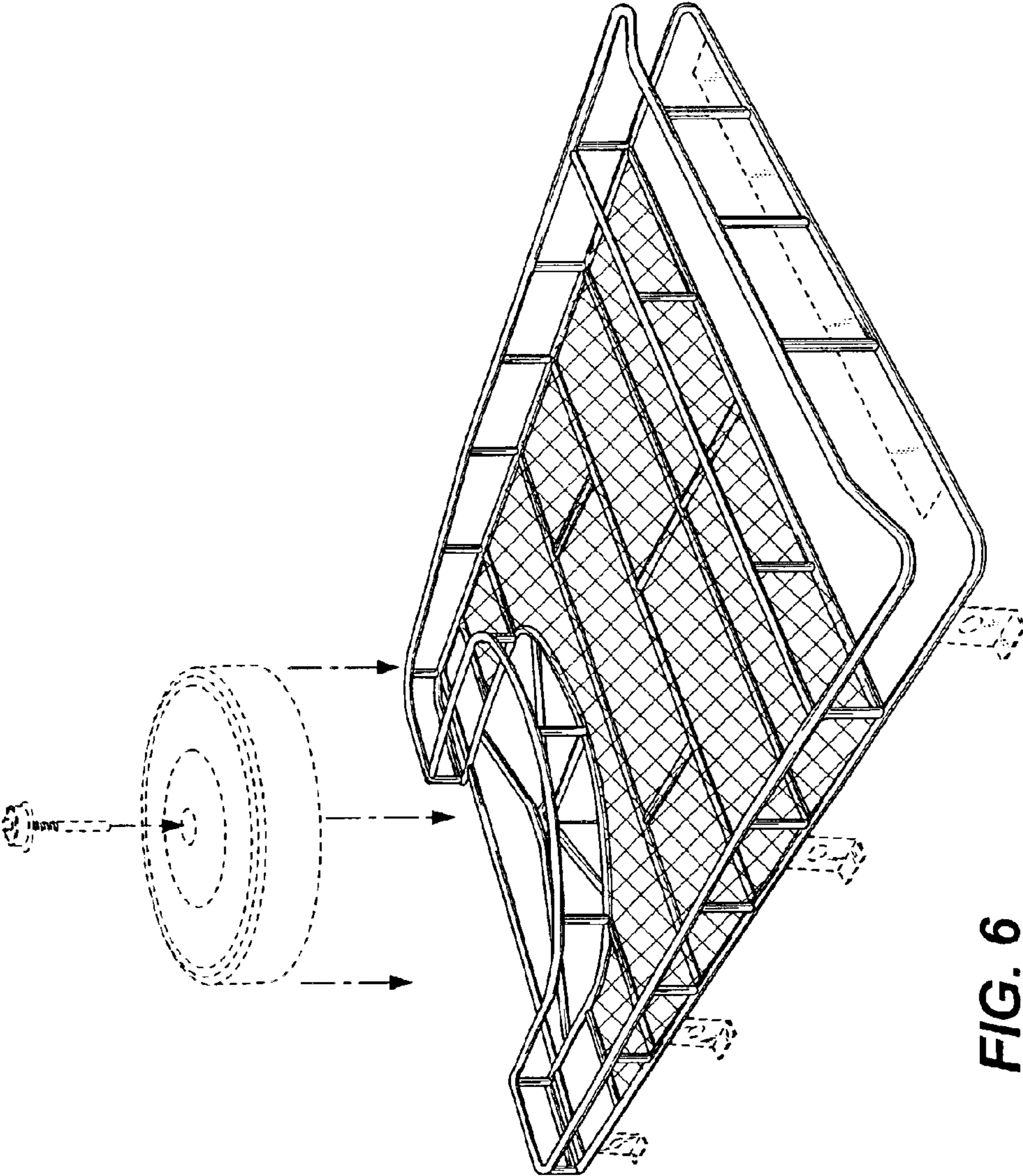

FIG. 6