

US00D508005S

(12) **United States Design Patent** (10) **Patent No.:** **US D508,005 S**  
**Ikeda et al.** (45) **Date of Patent:** **\*\* Aug. 2, 2005**

(54) **RIM FOR A MOTORCYCLE**  
 (75) Inventors: **Kuniyasu Ikeda**, Tokyo (JP); **Masao Tamaki**, Tokyo (JP)

D35,075 S \* 9/1901 MacLulich ..... D12/208  
 2,126,222 A \* 8/1938 Schwinn ..... 301/95.106  
 D281,967 S \* 12/1985 Hashimoto ..... D12/208  
 D439,875 S \* 4/2001 Zemlicka ..... D12/208

(73) Assignee: **R & D Taro, Inc.**, Hamamatsu (JP)  
 (\*\*) Term: **14 Years**

\* cited by examiner

*Primary Examiner*—Stacia Cadmus  
 (74) *Attorney, Agent, or Firm*—Adams & Wilks

(21) Appl. No.: **29/169,762**

(57) **CLAIM**

(22) Filed: **Oct. 25, 2002**

The ornamental design for a rim for a motorcycle, as shown and described.

(30) **Foreign Application Priority Data**

May 20, 2002 (JP) ..... 2002-013294

**DESCRIPTION**

(51) **LOC (8) Cl.** ..... **12-16**  
 (52) **U.S. Cl.** ..... **D12/208**  
 (58) **Field of Search** ..... D12/204–213;  
 301/64.1, 65, 37.1, 95.101, 95.102

FIG. 1 is a perspective view of a rim for a motorcycle showing our new design;  
 FIG. 2 is a front view thereof;  
 FIG. 3 is a plan view thereof;  
 FIG. 4 is a right side view thereof;  
 FIG. 5 is a sectional view thereof taken along line 5—5 in FIG. 2;  
 FIG. 6 is an enlarged sectional view thereof taken along line 6—6 in FIG. 5; and,  
 FIG. 7 is an enlarged sectional view thereof taken along line 7—7 in FIG. 5.

(56) **References Cited**

**U.S. PATENT DOCUMENTS**

D23,015 S \* 1/1894 Ames ..... D12/208  
 D33,834 S \* 1/1901 Wilmot ..... D12/208  
 D34,005 S \* 1/1901 Ducasble ..... D12/208  
 D34,006 S \* 1/1901 Ducasble ..... D12/208

**1 Claim, 2 Drawing Sheets**

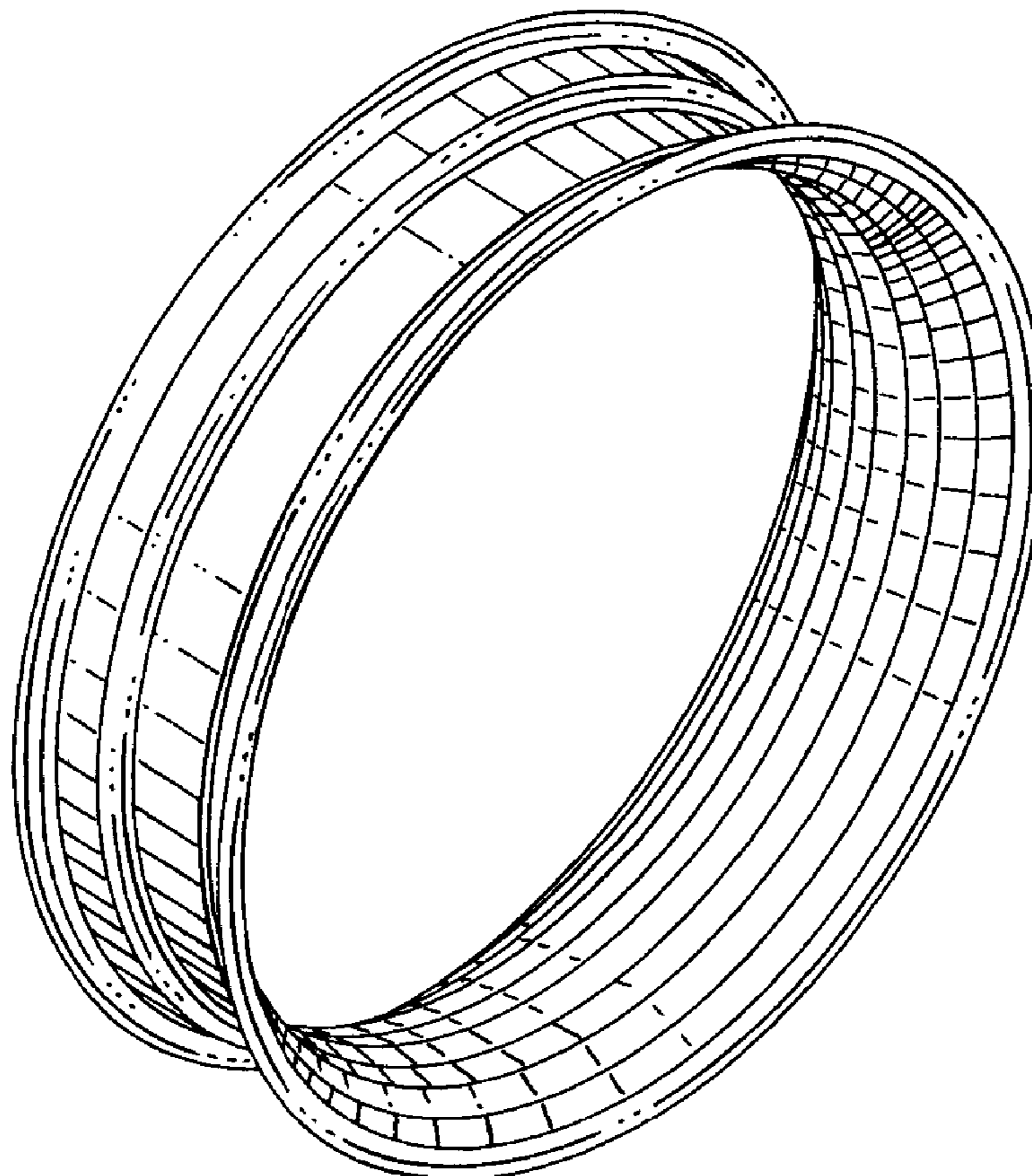

**FIG. 1**

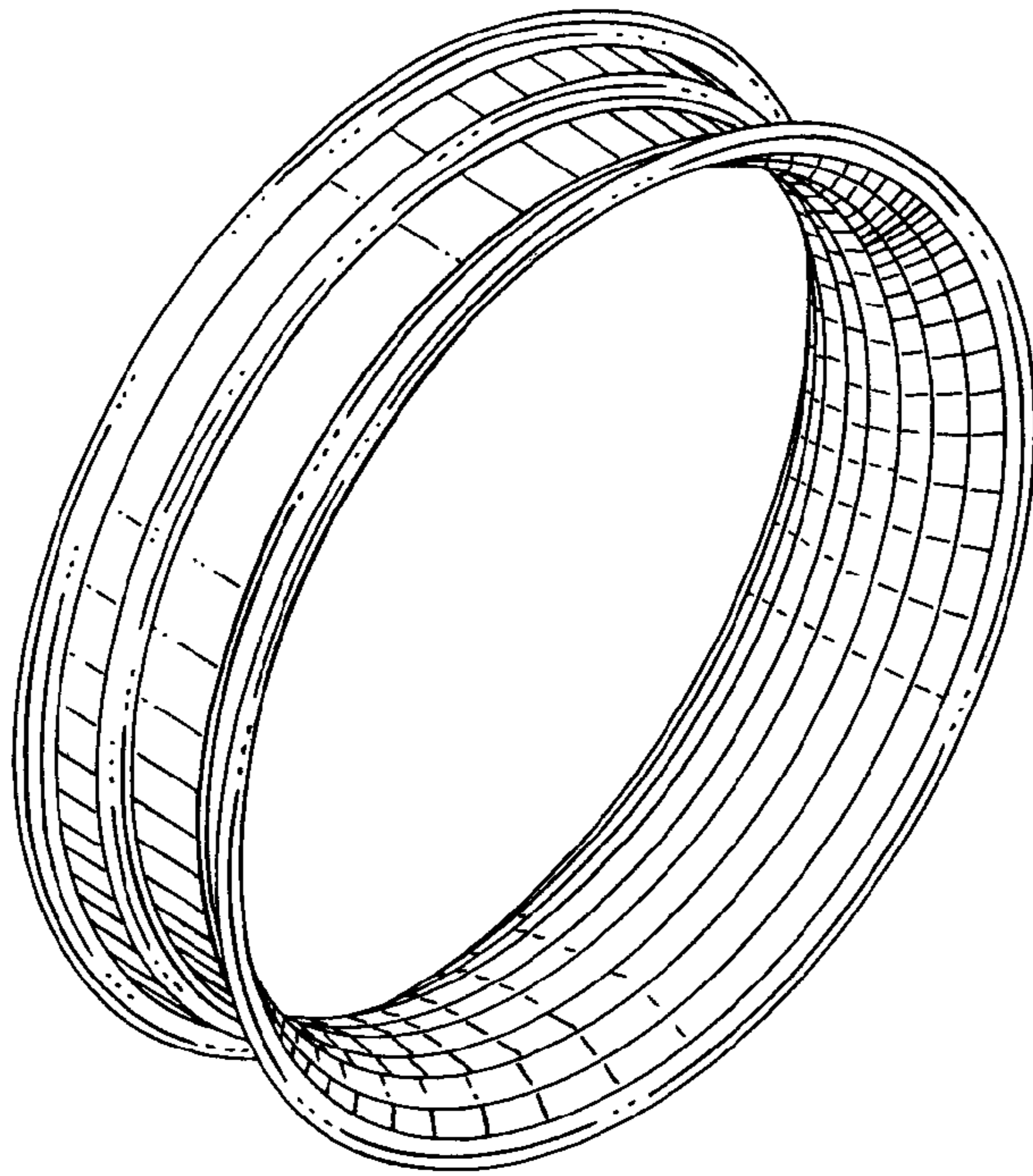

**FIG. 2**

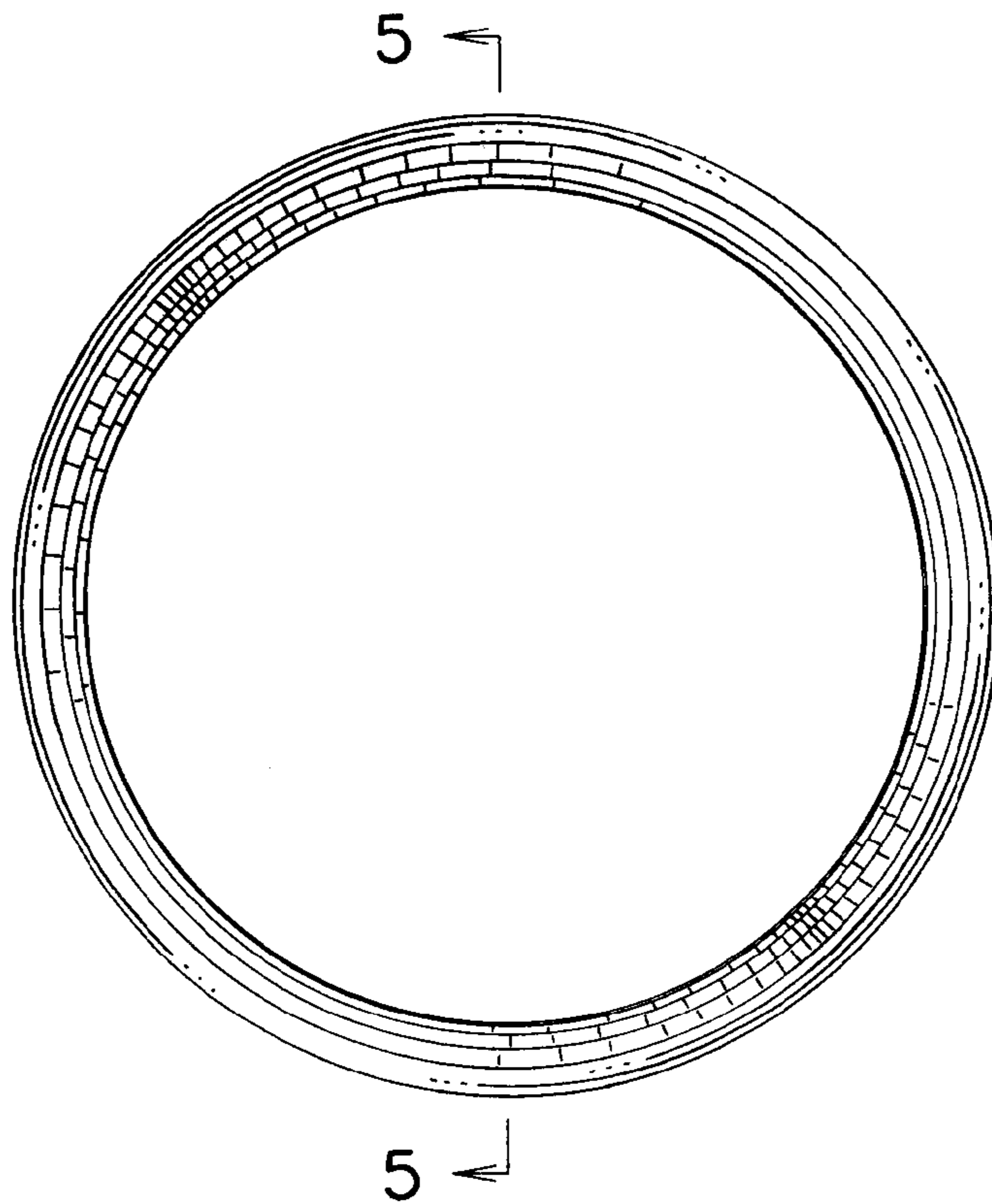

**FIG. 3**

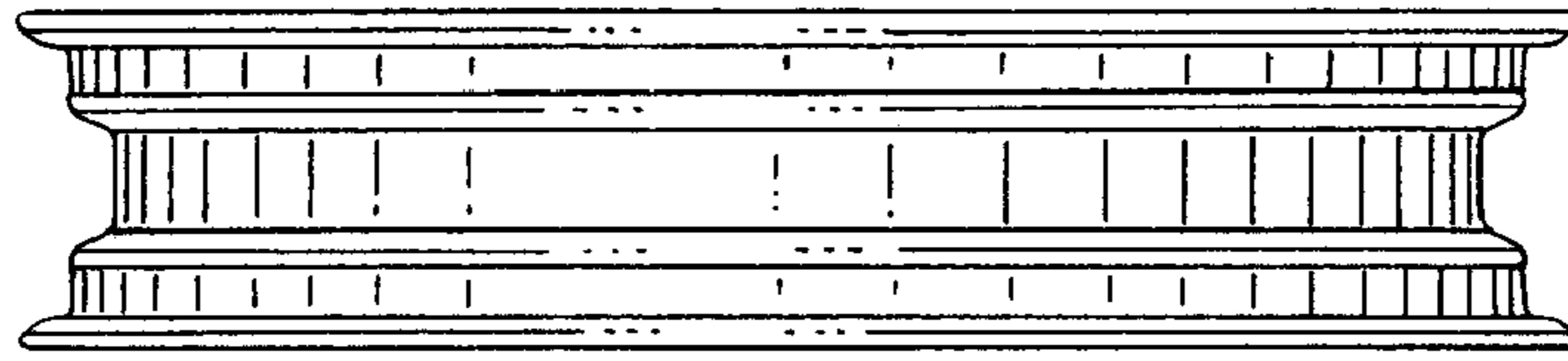

**FIG. 4**

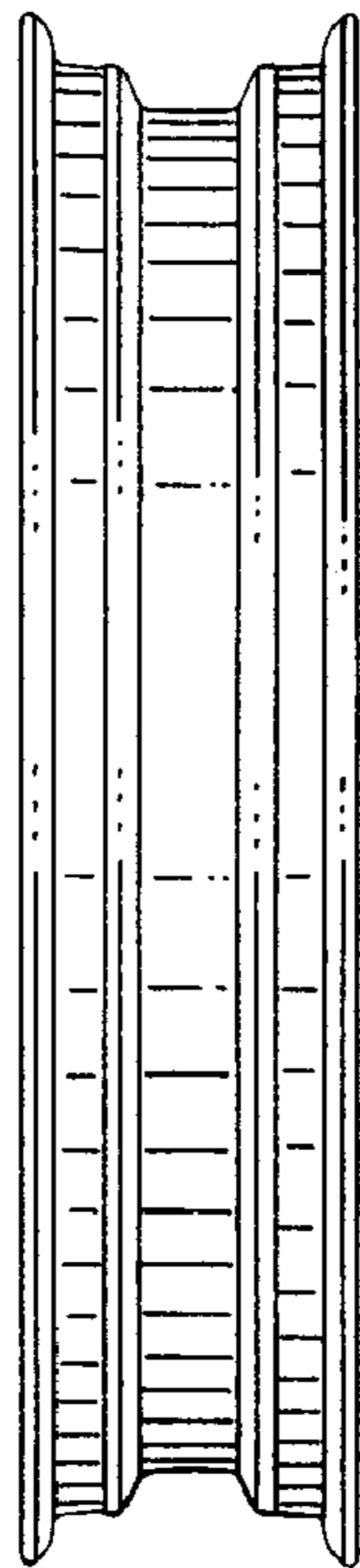

**FIG. 5**

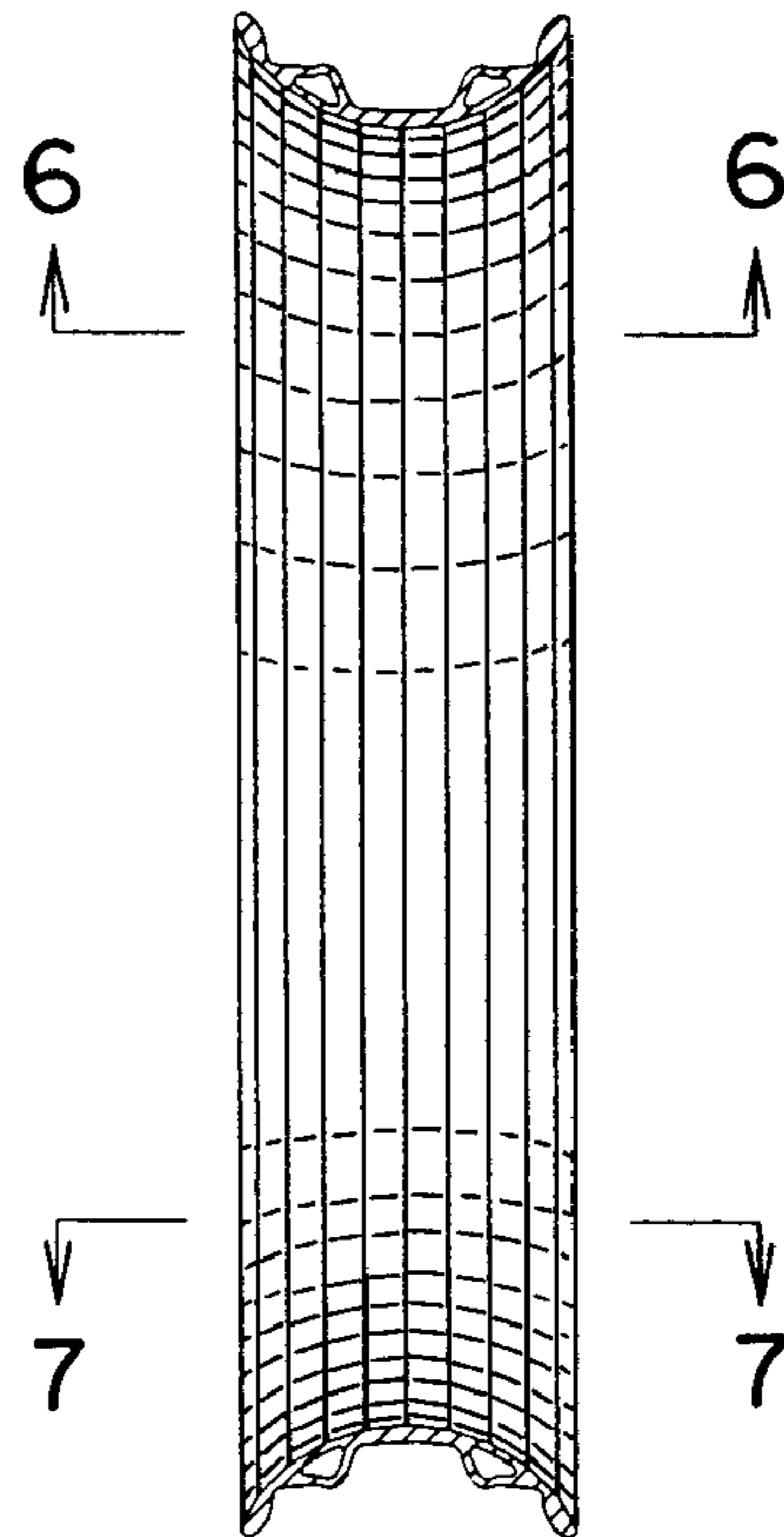

**FIG. 6**

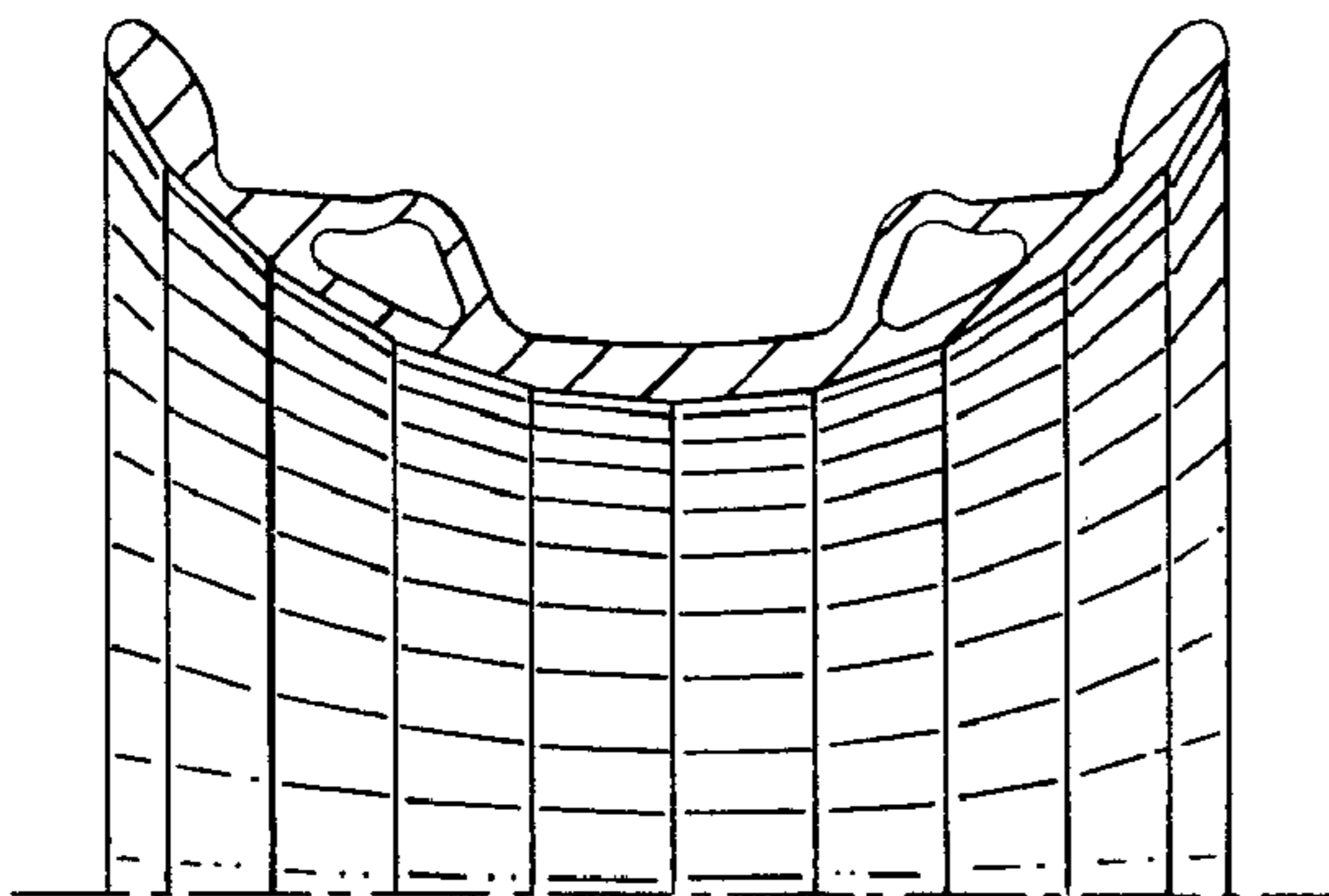

**FIG. 7**

