

US00D507619S

(12) **United States Design Patent**
Shiloni

(10) **Patent No.:** **US D507,619 S**
(45) **Date of Patent:** **** Jul. 19, 2005**

(54) **HAND GUARD FOR A RIFLE**
(75) Inventor: **Amnon Shiloni, Shoam (IL)**
(73) Assignee: **First Samco Inc., Southampton, PA (US)**
(**) Term: **14 Years**

5,826,363 A	10/1998	Olson	42/75.01
5,848,491 A	* 12/1998	Biemont	42/85
5,930,935 A	8/1999	Griffin	42/105
6,134,823 A	10/2000	Griffin	42/105
D442,251 S	* 5/2001	Fitzgerald, Jr.	D22/107
6,293,040 B1	9/2001	Luth	42/75.01
6,381,895 B1	5/2002	Keeney et al.	42/124
D477,855 S	* 7/2003	Selvaggio	D22/108
2003/0074822 A1	4/2003	Faifer	42/71.01
2003/0230022 A1	* 12/2003	Battaglia	42/111

(21) Appl. No.: **29/181,026**
(22) Filed: **May 2, 2003**

(30) **Foreign Application Priority Data**

Nov. 4, 2002 (IL)	37166
Nov. 4, 2002 (IL)	37167
Nov. 4, 2002 (IL)	37168
Nov. 4, 2002 (IL)	37169

(51) **LOC (8) Cl.** **22-01**
(52) **U.S. Cl.** **D22/108**
(58) **Field of Search** D22/100, 103,
D22/108, 199; 42/71.01, 75.01, 77, 90,
105, 106, 111, 117, 125; 89/1.42, 14.1,
129.01, 191.02

(56) **References Cited**

U.S. PATENT DOCUMENTS

718,062 A	*	1/1903	Weed	116/23
859,932 A		7/1907	Edwards	
1,037,486 A		9/1912	Johnson	
1,290,853 A	*	1/1919	Sturgeon	89/14.1
2,312,150 A		2/1943	Conner	42/75
2,361,932 A	*	11/1944	Fay	89/14.1
2,674,822 A		4/1954	Studler	42/71
2,965,994 A		12/1960	Sullivan	42/71
3,641,691 A		2/1972	Ellis et al.	42/1 F
4,536,982 A		8/1985	Bredbury et al.	42/71 R
4,663,875 A		5/1987	Tatro	42/71.01
4,733,489 A		3/1988	Kurak	42/77
D300,161 S		3/1989	Baldus et al.	D22/108
5,010,676 A		4/1991	Kennedy	42/71.01
5,103,714 A		4/1992	LaFrance	89/129.01
5,198,600 A		3/1993	E'Nama	42/90
5,343,650 A		9/1994	Swan	42/100
5,590,484 A		1/1997	Mooney et al.	42/100

OTHER PUBLICATIONS

U.S. Appl. No. 29/157,270, filed Mar. 14, 2002, Faifer.

* cited by examiner

Primary Examiner—Louis S. Zarfaz
Assistant Examiner—Melanie Levy
(74) *Attorney, Agent, or Firm*—Drinker Biddle & Reath LLP

(57) **CLAIM**

I claim the ornamental design for a hand guard for a rifle, as shown and described.

DESCRIPTION

FIG. 1 is a perspective view of a hand guard for a rifle assembled from two identical halves according to the present invention, as seen from the front, above and from the left side.
FIG. 2 is a top plan view of the hand guard of FIG. 1, the bottom plan view being identical if obtained by rotating the hand guard 180 degrees about its long axis.
FIG. 3 is a left side elevation of the hand guard of FIG. 1, the right side elevation being an inverted mirror image if obtained by rotating the hand guard 180 degrees about its short axis.
FIG. 4 is a front elevation of the hand guard of FIG. 1.
FIG. 5 is a rear elevation of the hand guard of FIG. 1.
FIG. 6 is a perspective view of the one of the identical halves of the hand guard shown in FIG. 1, as seen from the front, above and from the left side.
FIG. 7 is a top plan view of the hand guard half of FIG. 6.
FIG. 8 is a left side elevation of the hand guard half of FIG. 6.

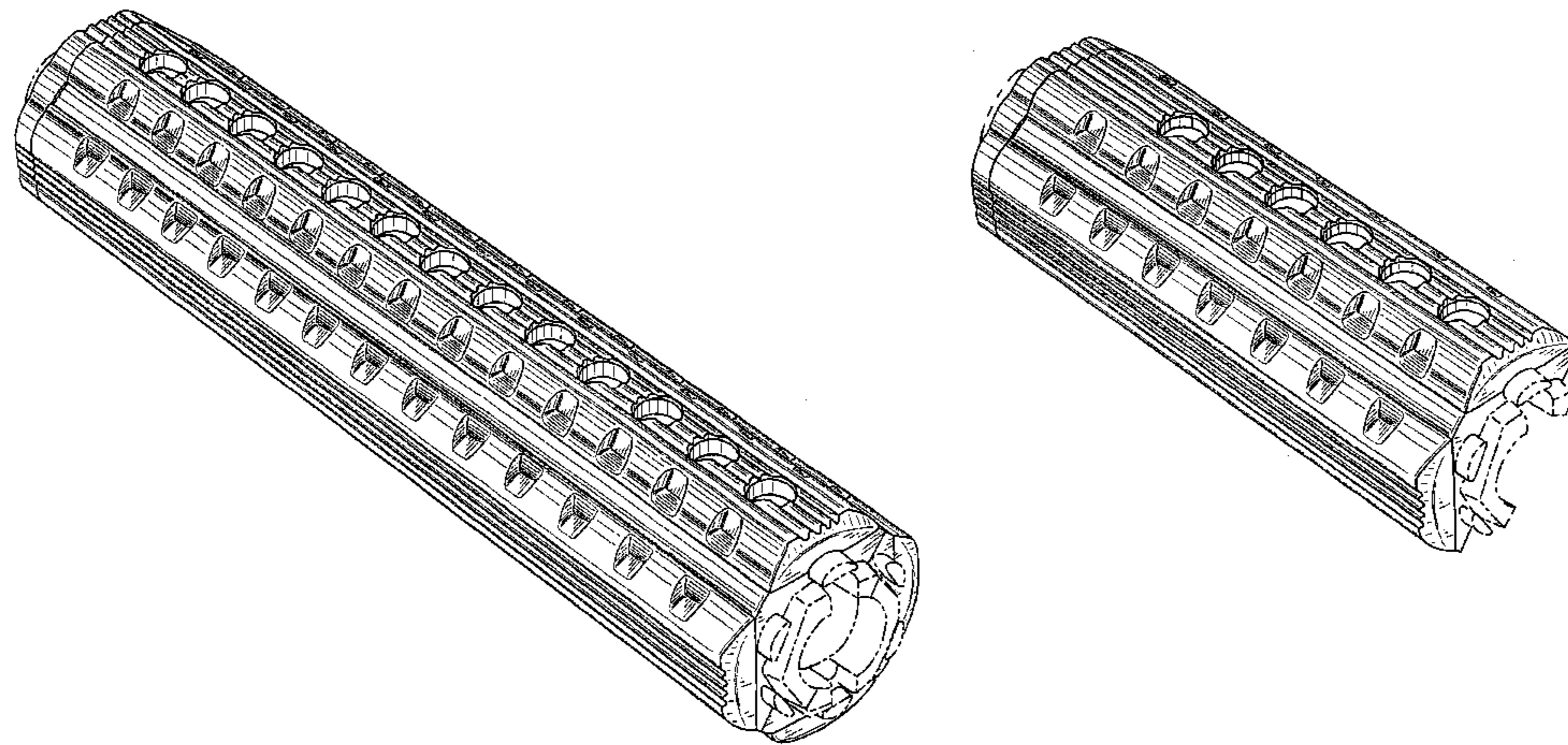

FIG. 9 is a bottom plan view of the hand guard half of FIG. 6, the bottom plan view obtained by rotating that of FIG. 7 180 degrees about its long axis.

FIG. 10 is a right side elevation of the hand guard half of FIG. 6, the right side elevation obtained by rotating that of FIG. 8 180 degrees about its long axis.

FIG. 11 is a front elevation of the hand guard half of FIG. 6.

FIG. 12 is a rear elevation of the hand guard half of FIG. 6.

FIG. 13 is a perspective view of the hand guard half of FIG. 6 with its rail covers removed, as seen from the front, above and from the left side.

FIG. 14 is a top plan view of the hand guard half as shown in FIG. 13.

FIG. 15 is a left side elevation of the hand guard half as shown in FIG. 13.

FIG. 16 is a bottom plan view of the hand guard half as shown in FIG. 13, the bottom plan view obtained by rotating that of FIG. 14 180 degrees about its long axis.

FIG. 17 is a right side elevation of the hand guard half as shown in FIG. 13, the right side elevation obtained by rotating that of FIG. 15 180 degrees about its long axis.

FIG. 18 is a front elevation of the hand guard half as shown in FIG. 13.

FIG. 19 is a rear elevation of the hand guard half as shown in FIG. 13.

FIG. 20 is a perspective view of a second embodiment of a hand guard half as seen from the front, above and from the left side.

FIG. 21 is a top plan view of the hand guard half of FIG. 20.

FIG. 22 is a left side elevation of the hand guard half of FIG. 20.

FIG. 23 is a bottom plan view of the hand guard half of FIG. 20, the bottom plan view obtained by rotating that of FIG. 21 180 degrees about its long axis.

FIG. 24 is a right side elevation of the hand guard half of FIG. 20, the right side elevation obtained by rotating that of FIG. 22 180 degrees about its long axis.

FIG. 25 is a front elevation of the hand guard half of FIG. 20.

FIG. 26 is a rear elevation of the hand guard half of FIG. 20.

FIG. 27 is a perspective view of the hand guard half of FIG. 20 with its rail covers removed, as seen from the front, above and from the left side.

FIG. 28 is a top plan view of the hand guard half as shown in FIG. 27.

FIG. 29 is a left side elevation of the hand guard half as shown in FIG. 27.

FIG. 30 is a bottom plan view of the hand guard half as shown in FIG. 27, the bottom plan view obtained by rotating that of FIG. 28 180 degrees about its long axis.

FIG. 31 is a right side elevation of the hand guard half as shown in FIG. 27, the right side elevation obtained by rotating that of FIG. 29 180 degrees about its long axis.

FIG. 32 is a front elevation of the hand guard half as shown in FIG. 27.

FIG. 33 is a rear elevation of the hand guard half as shown in FIG. 27.

FIG. 34 is a perspective view of an assembled hand guard formed from two identical hand guard halves as shown in FIG. 20, as seen from the front, above and from the left side.

FIG. 35 is a top plan view of the hand guard of FIG. 34, the bottom plan view being identical if obtained by rotating the hand guard 180 degrees about its long axis.

FIG. 36 is a left side elevation of the hand guard of FIG. 34, the right side elevation being an inverted mirror image if obtained by rotating the hand guard 180 degrees about its short axis.

FIG. 37 is a front elevation of the hand guard of FIG. 34; and,

FIG. 38 is rear elevation of the hand guard of FIG. 34.

The rifle engaging elements shown on the front and rear of the hand guard in broken lines form no part of the claimed design. The inside features of the hand guard, which are shown in broken lines, also form no part of the claimed design.

1 Claim, 22 Drawing Sheets

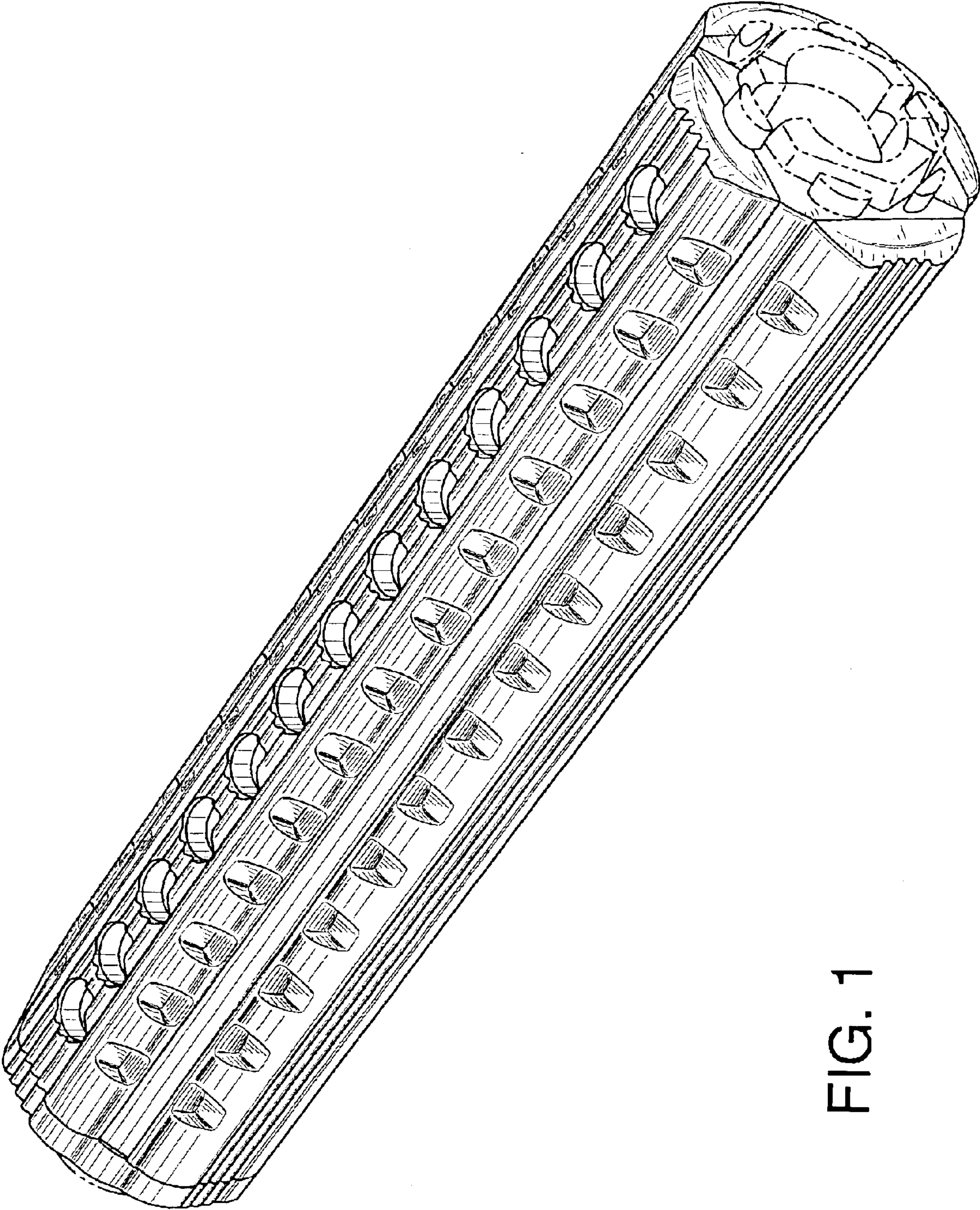

FIG. 1

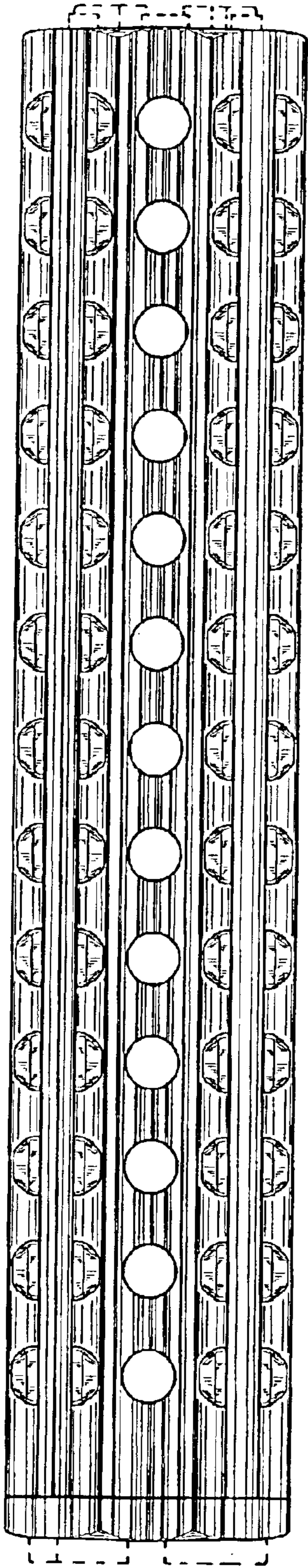

FIG. 2

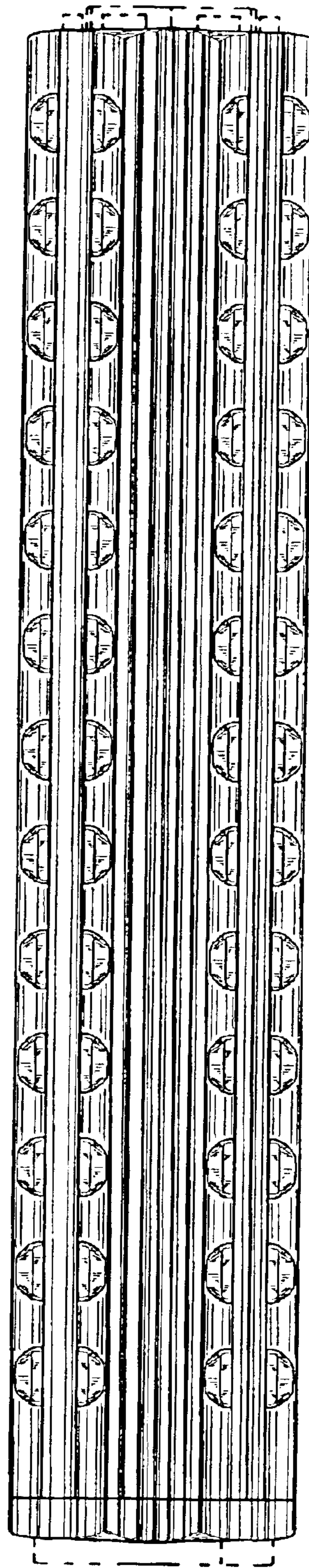

FIG. 3

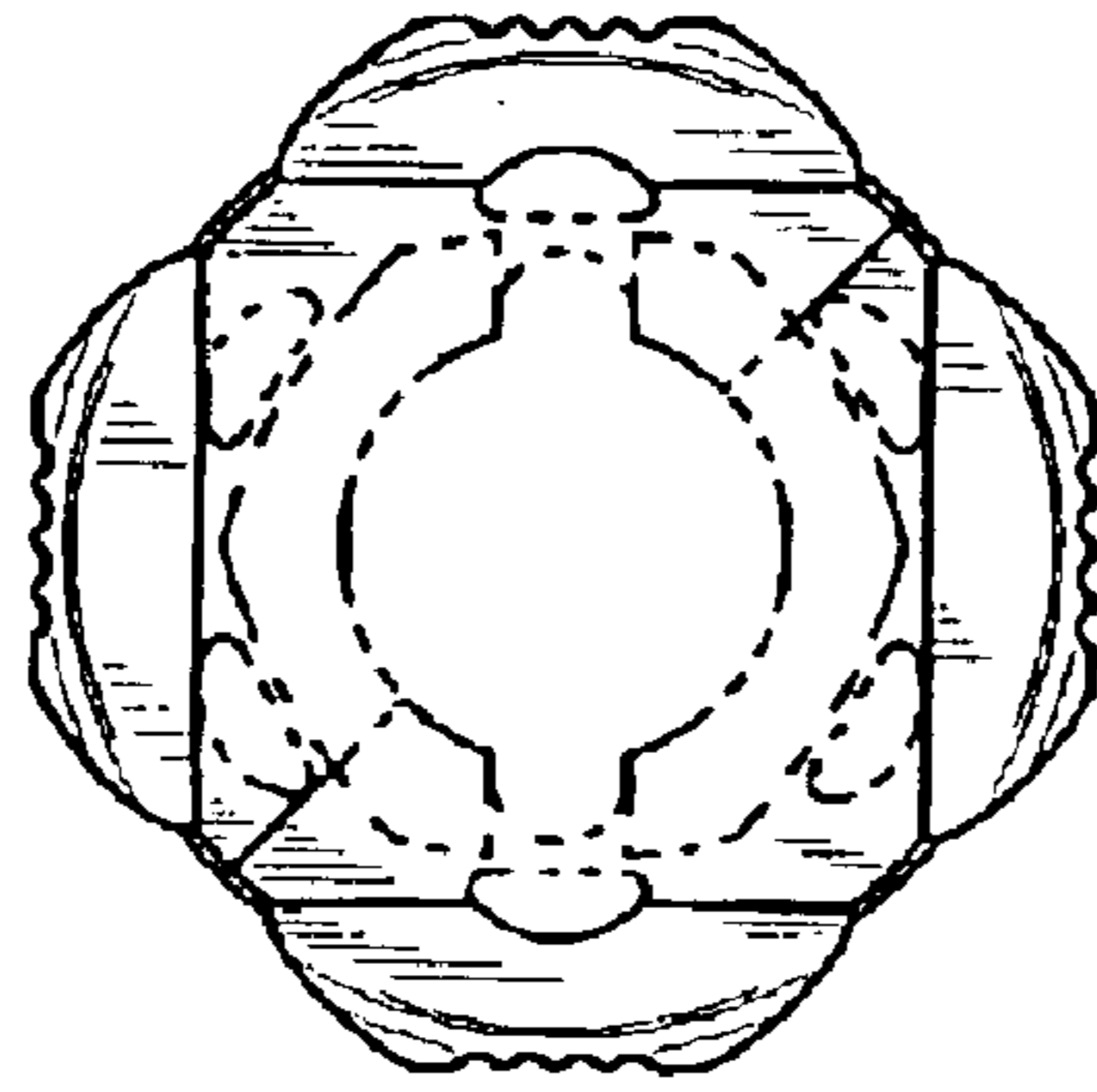

FIG. 4

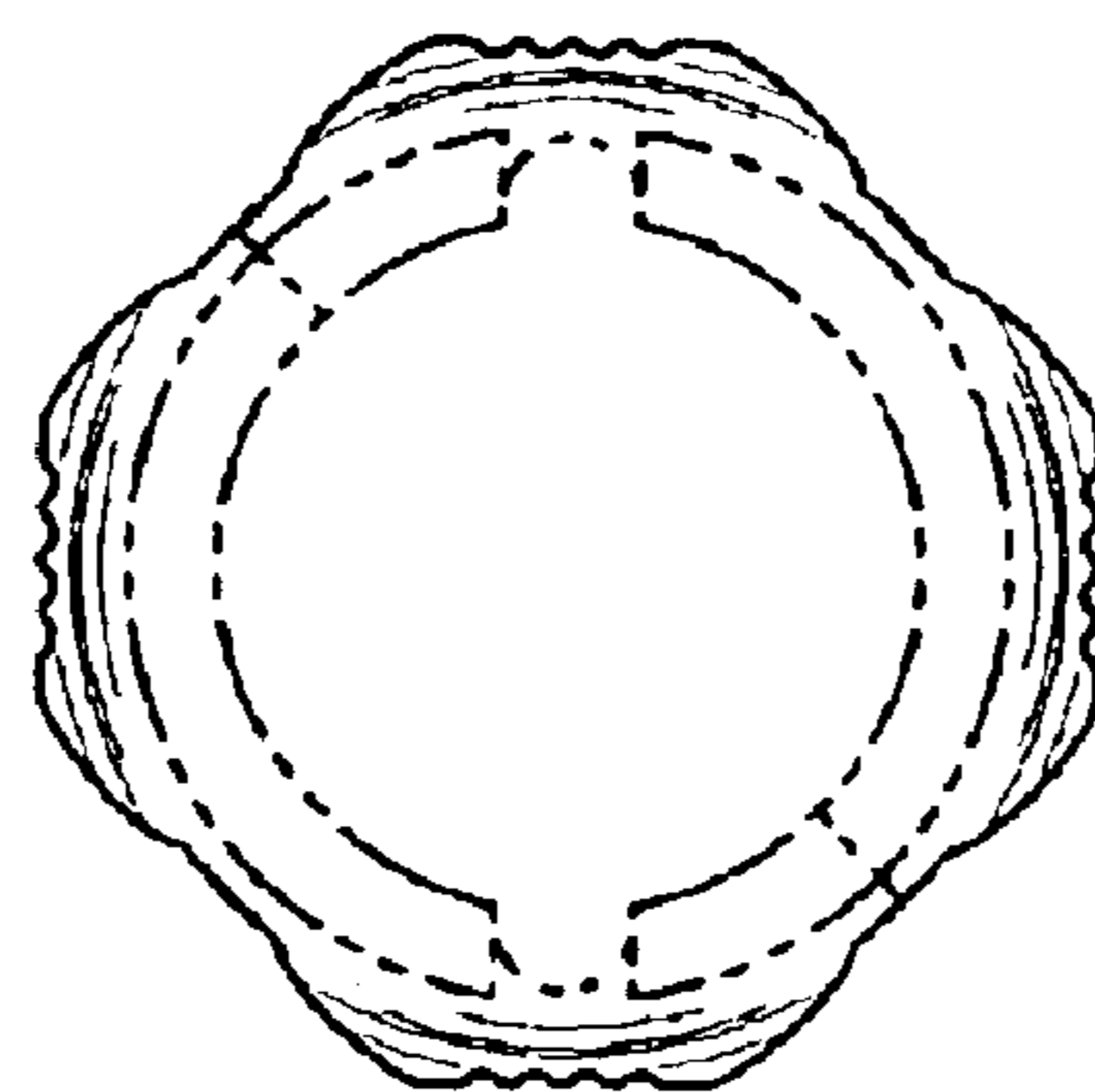

FIG. 5

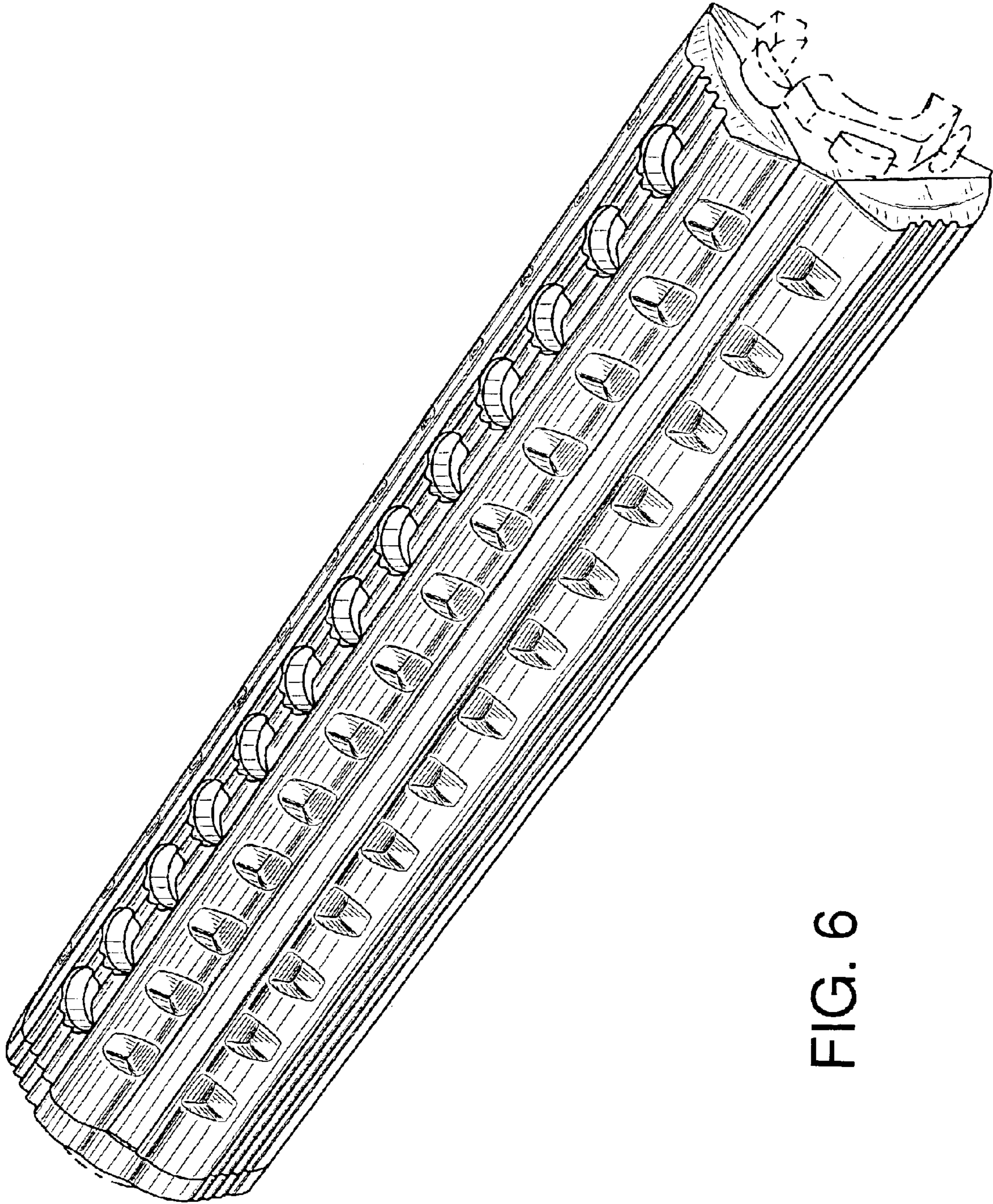

FIG. 6

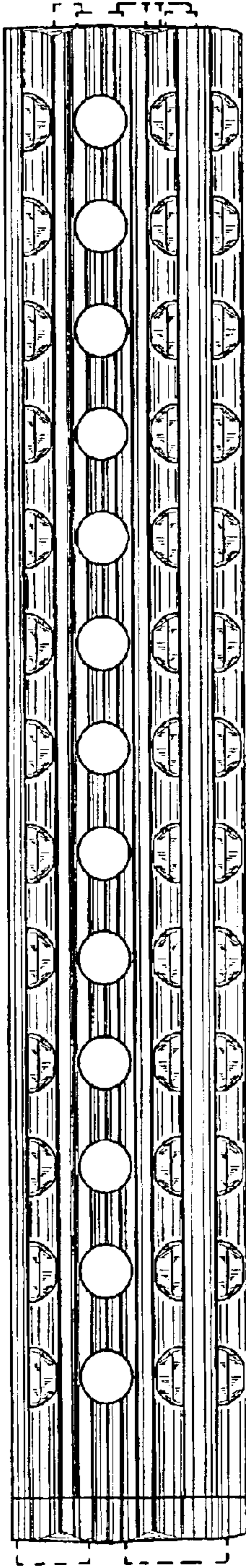

FIG. 7

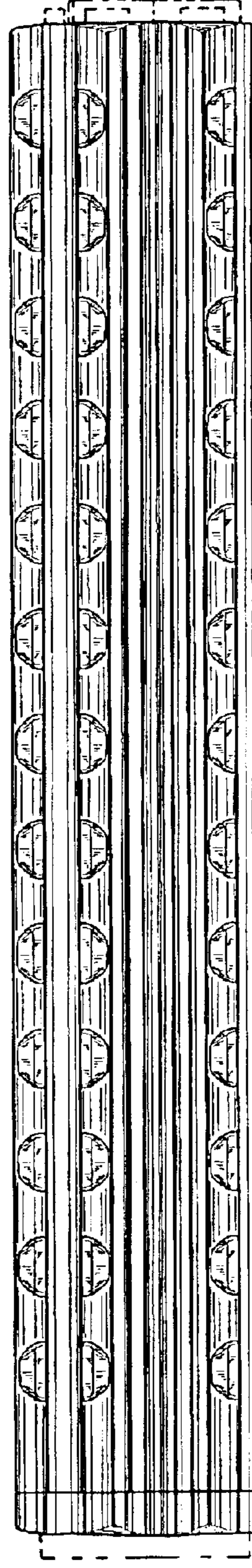

FIG. 8

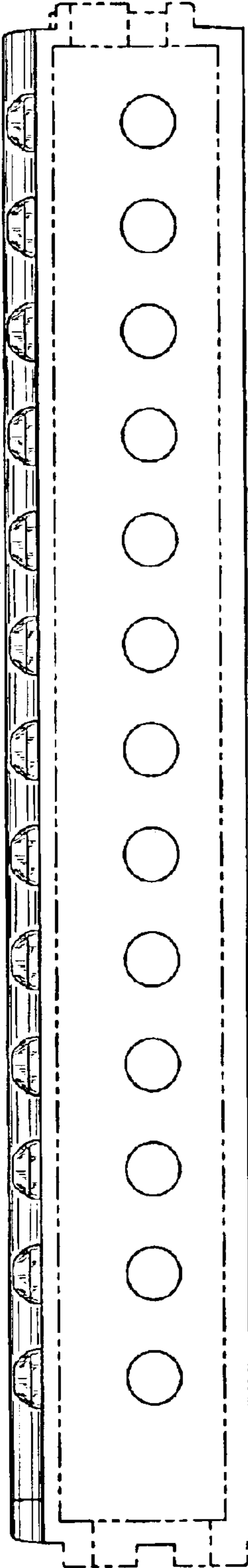

FIG. 9

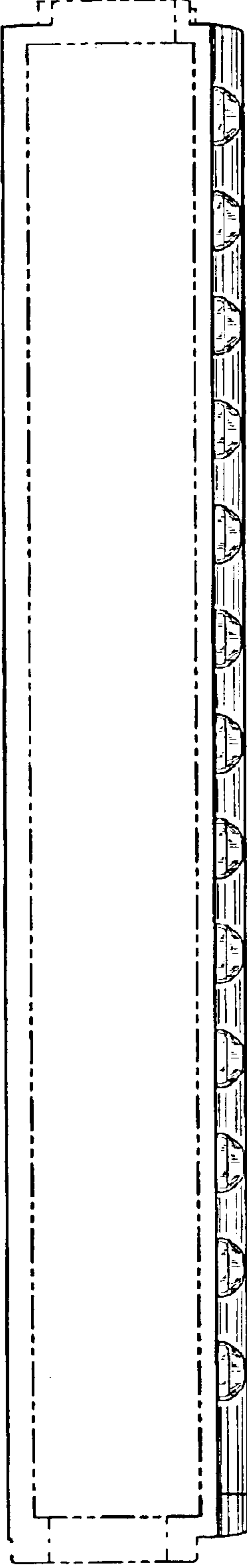

FIG. 10

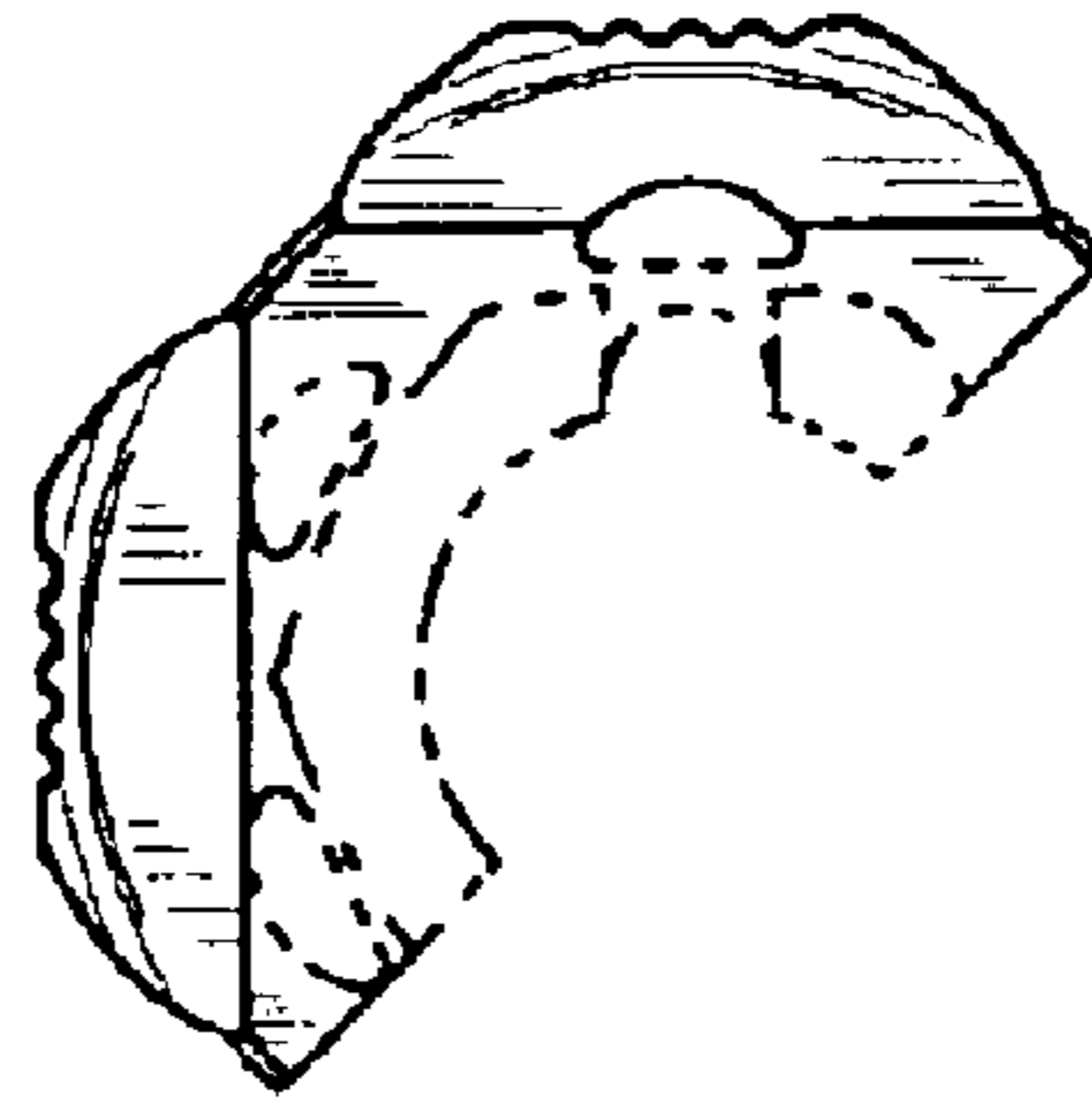

FIG. 11

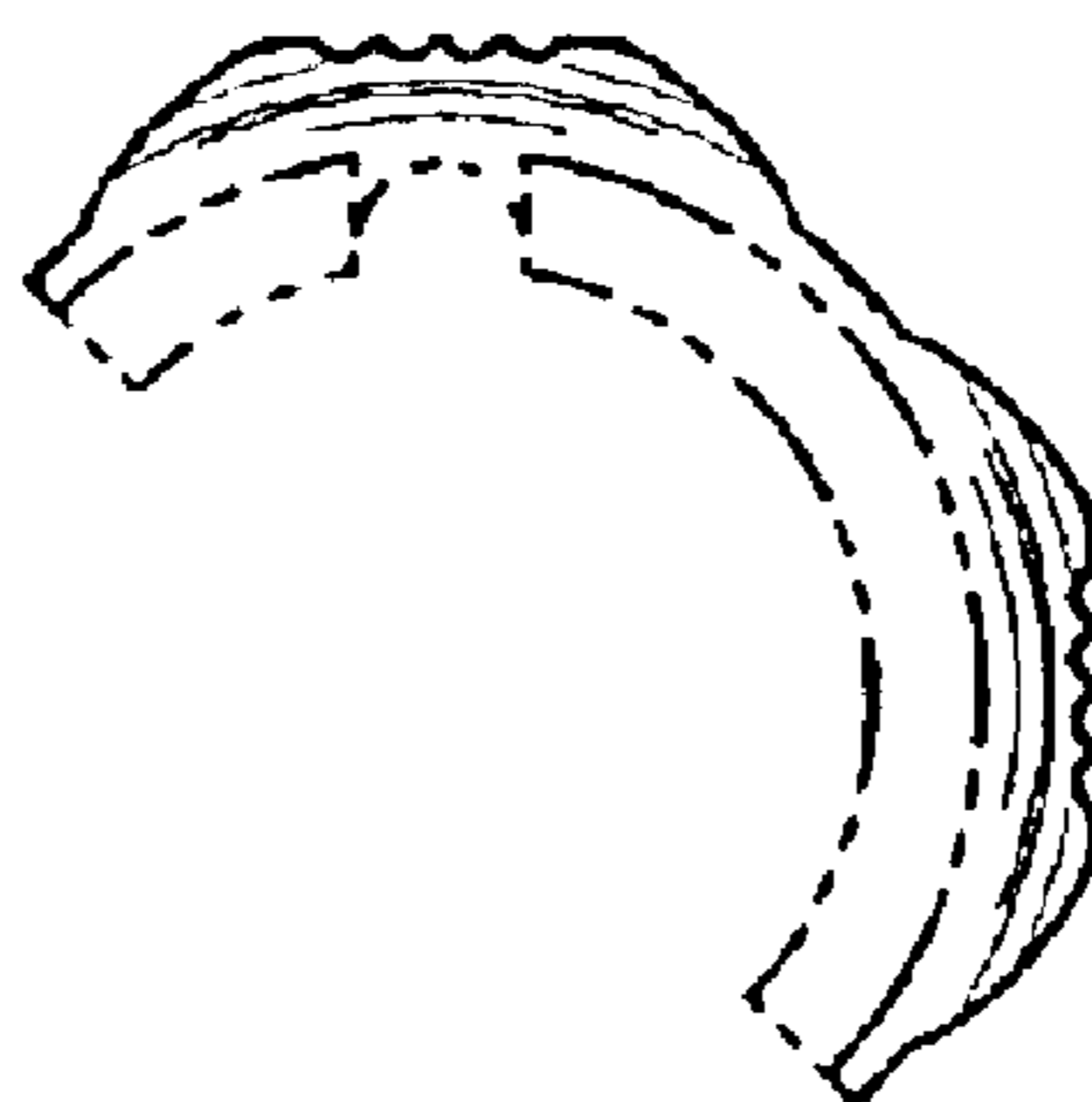

FIG. 12

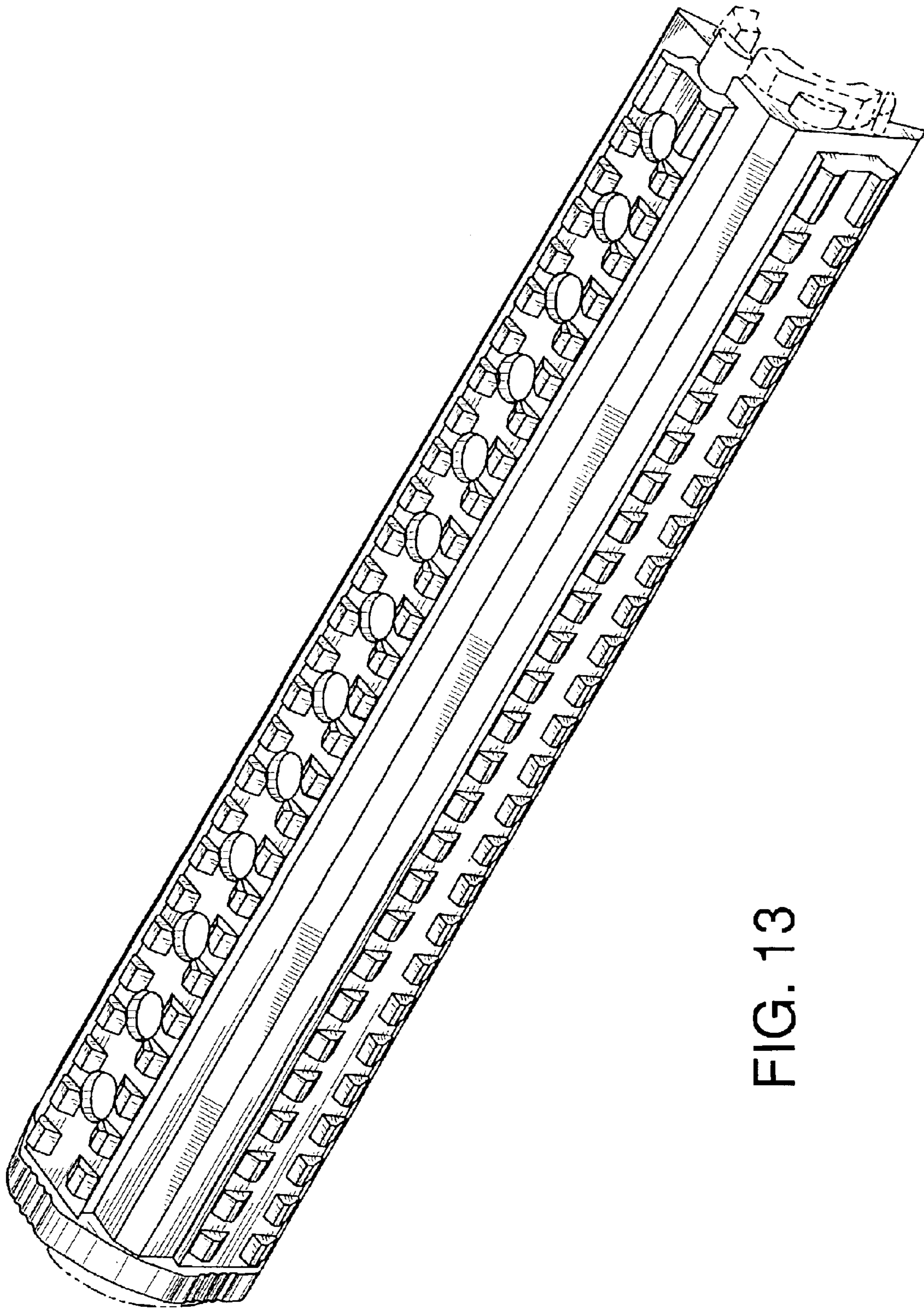

FIG. 13

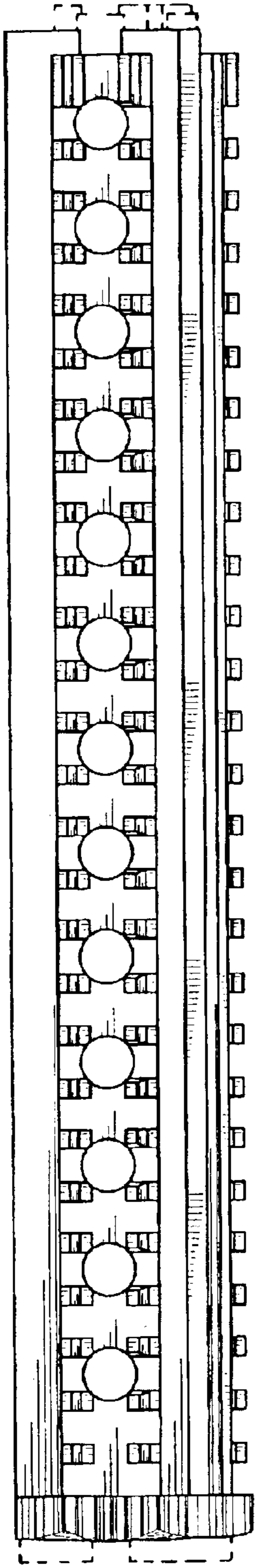

FIG. 14

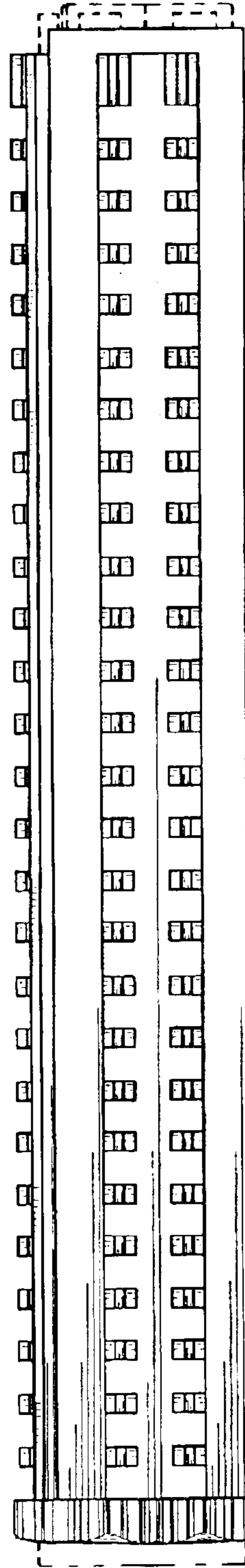

FIG. 15

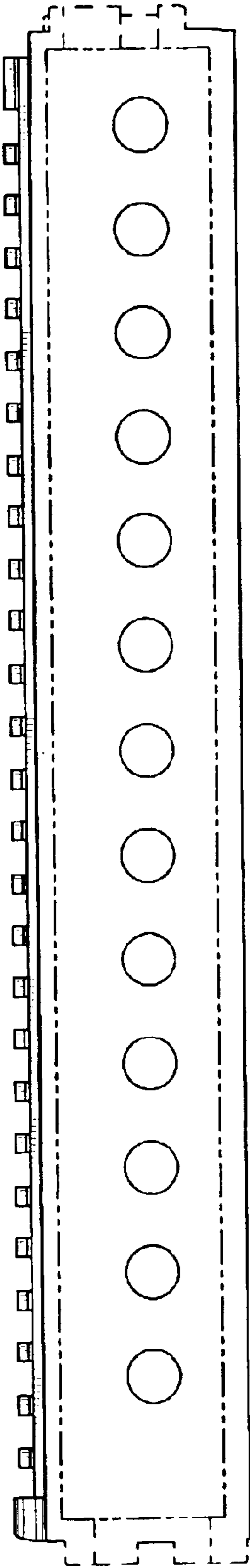

FIG. 16

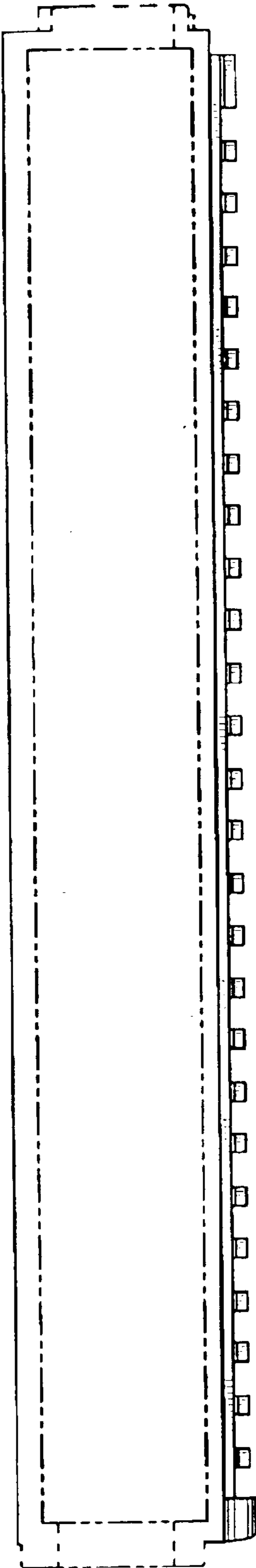

FIG. 17

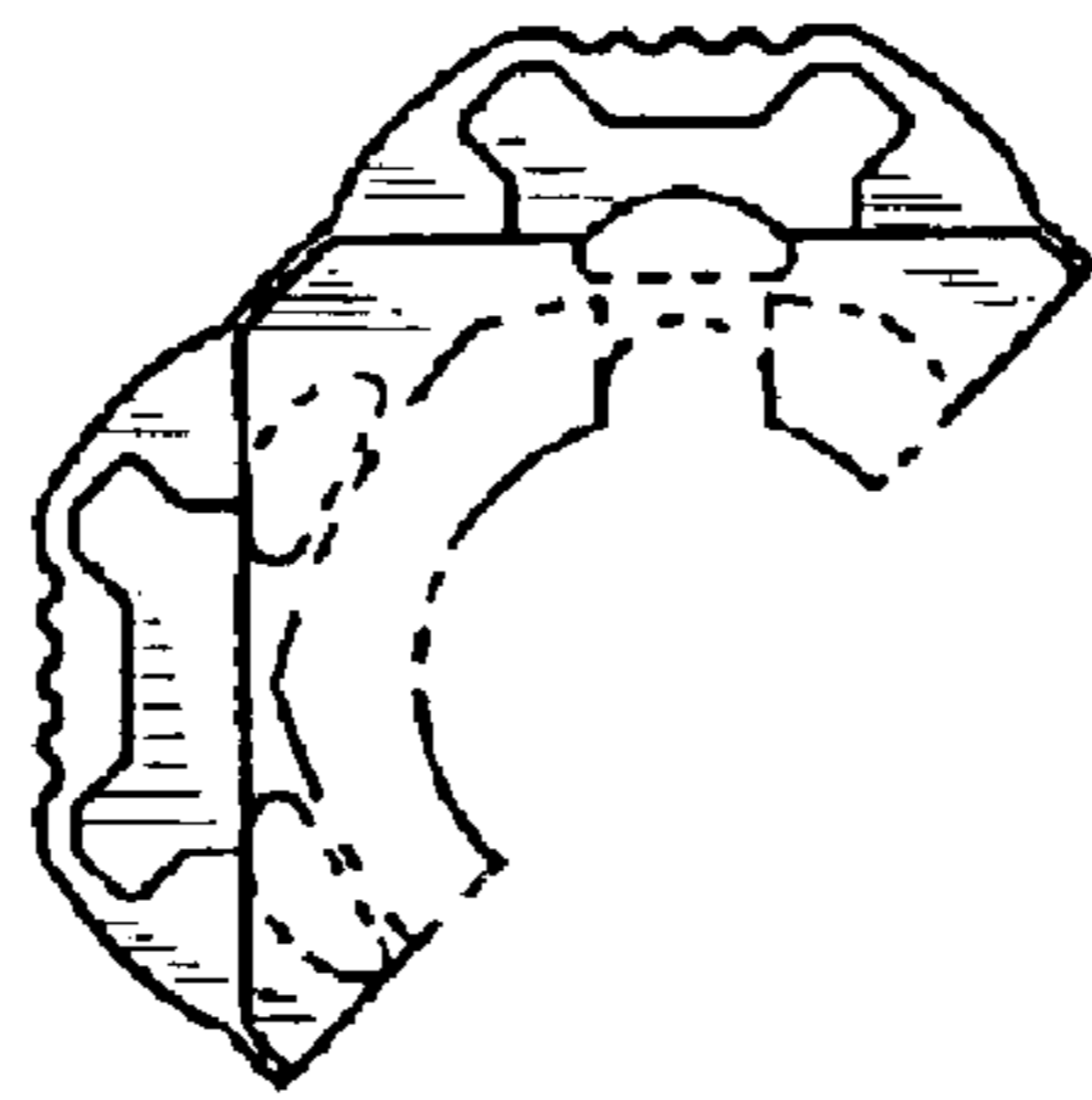

FIG. 18

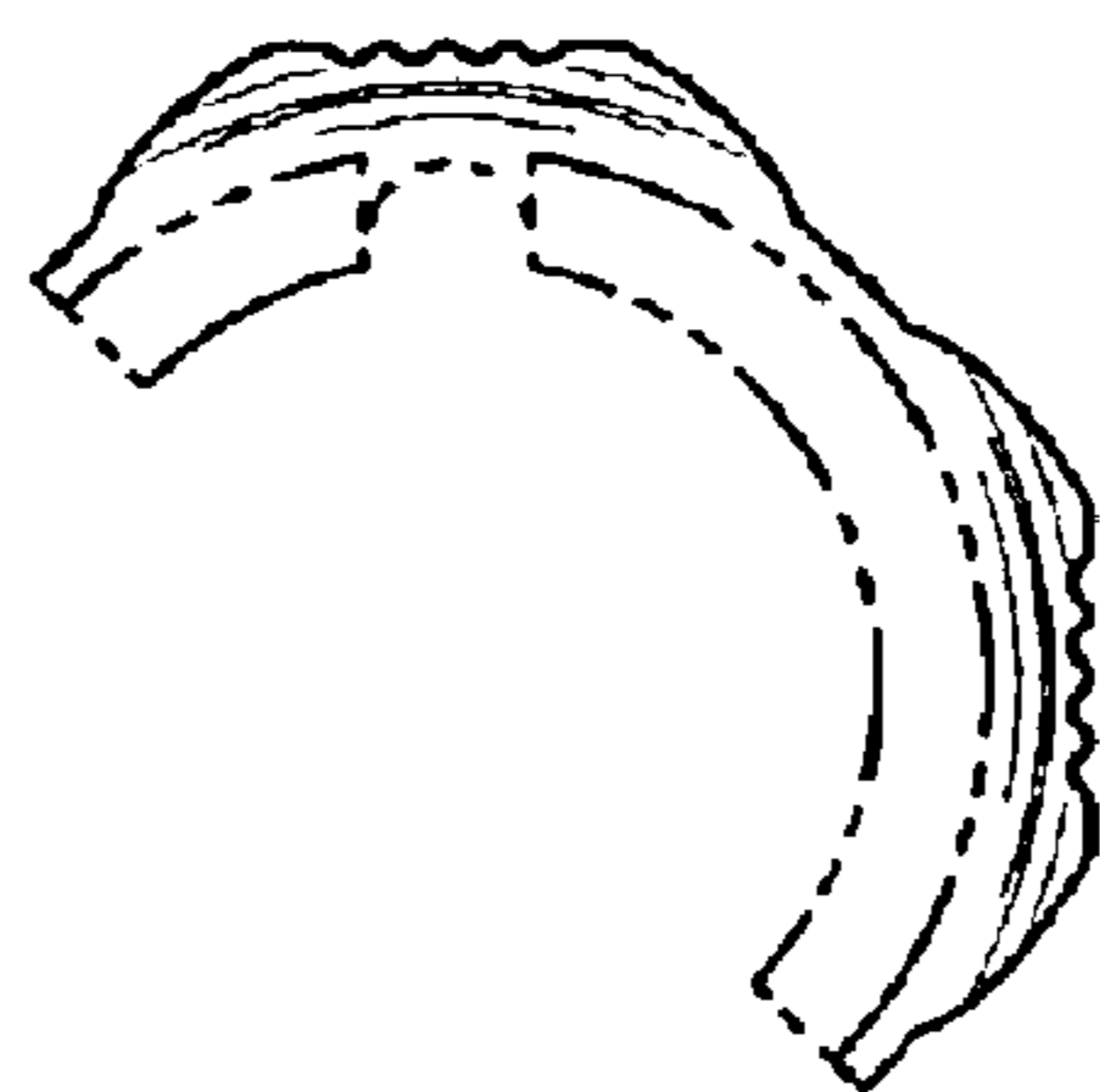

FIG. 19

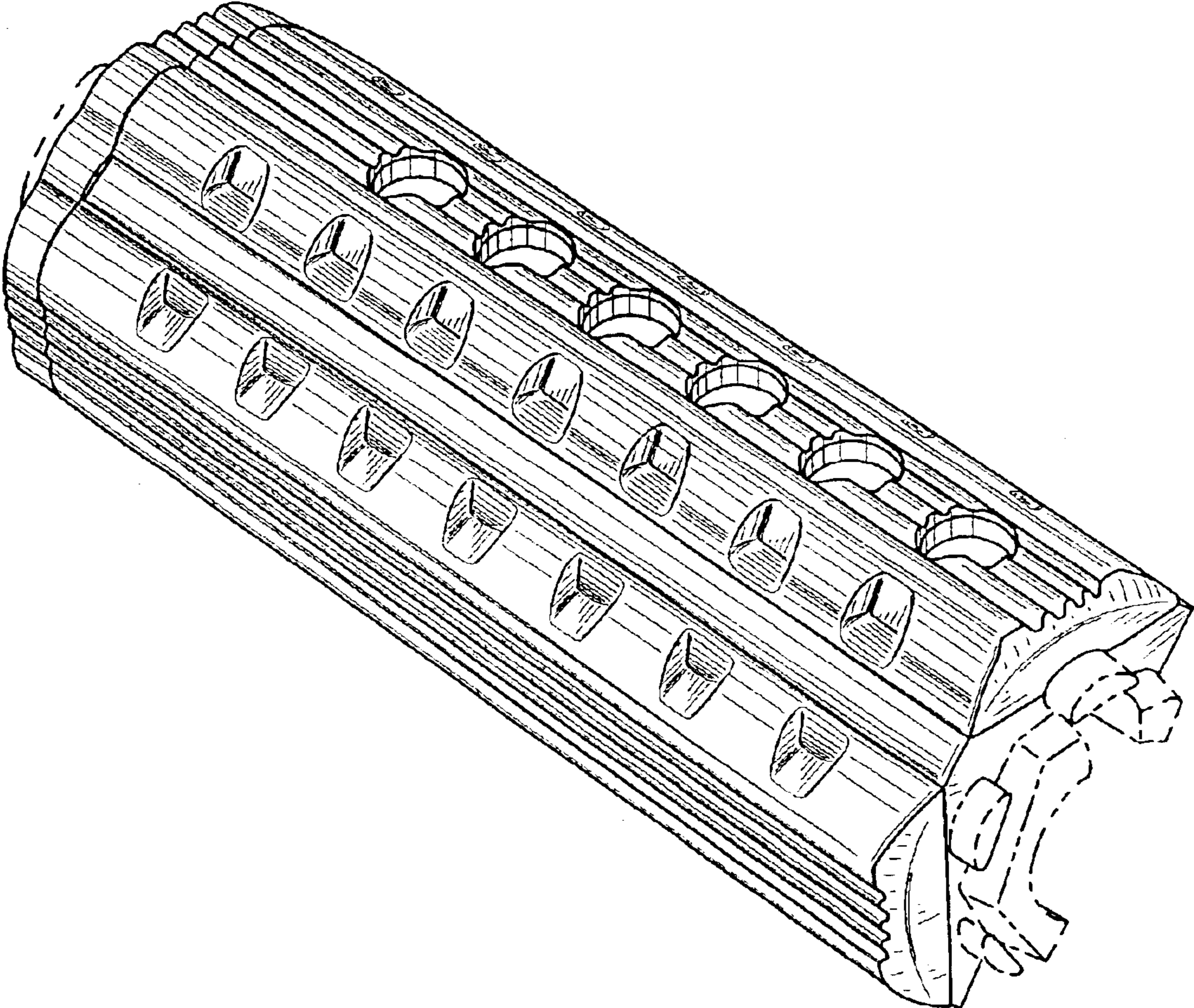

FIG. 20

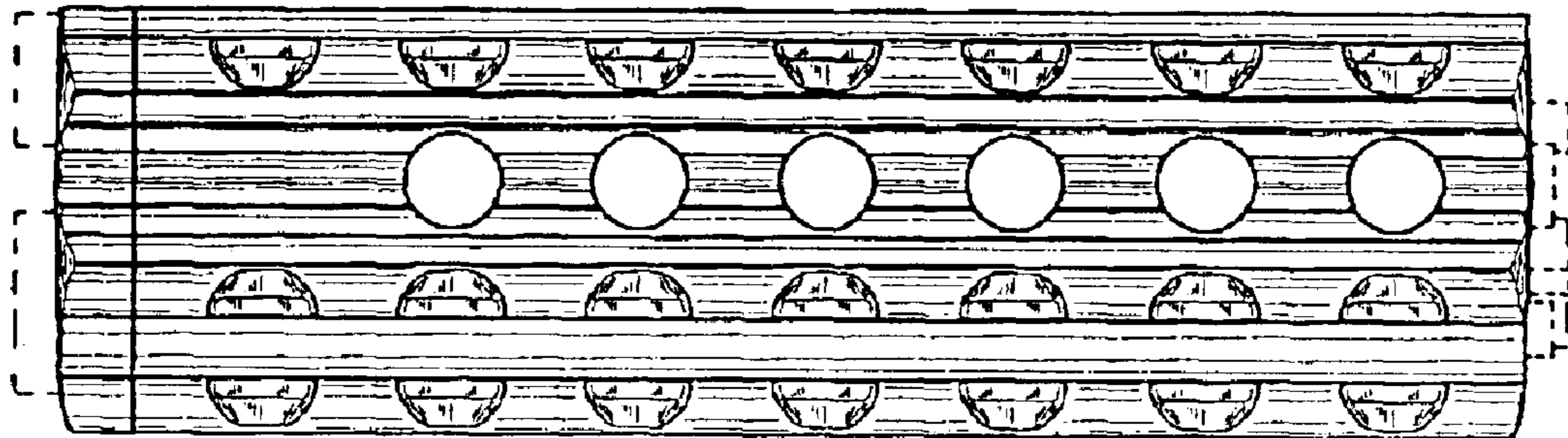

FIG. 21

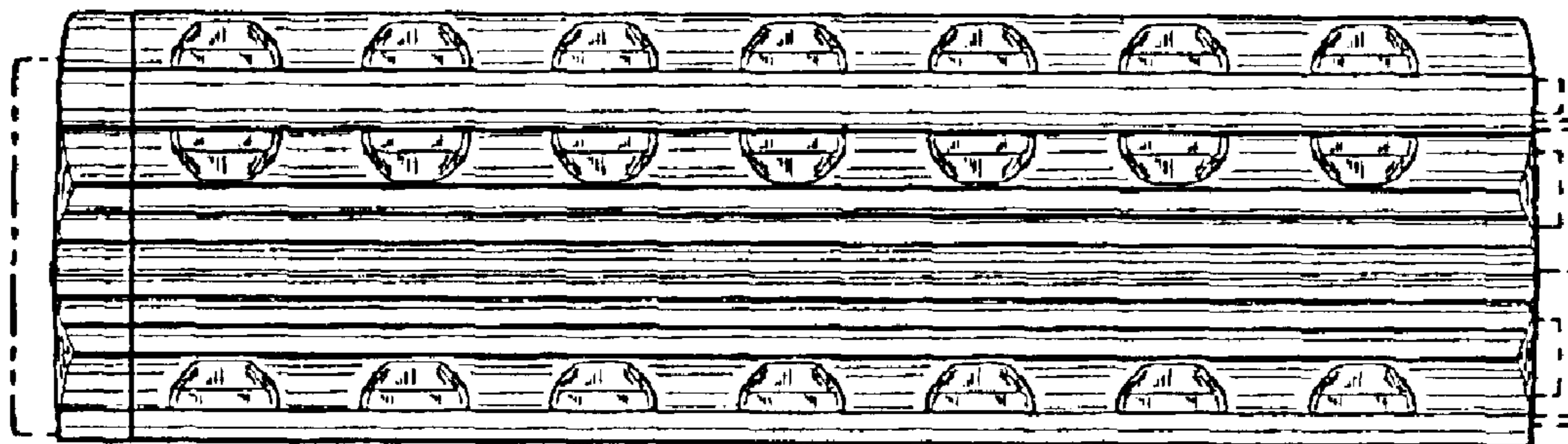

FIG. 22

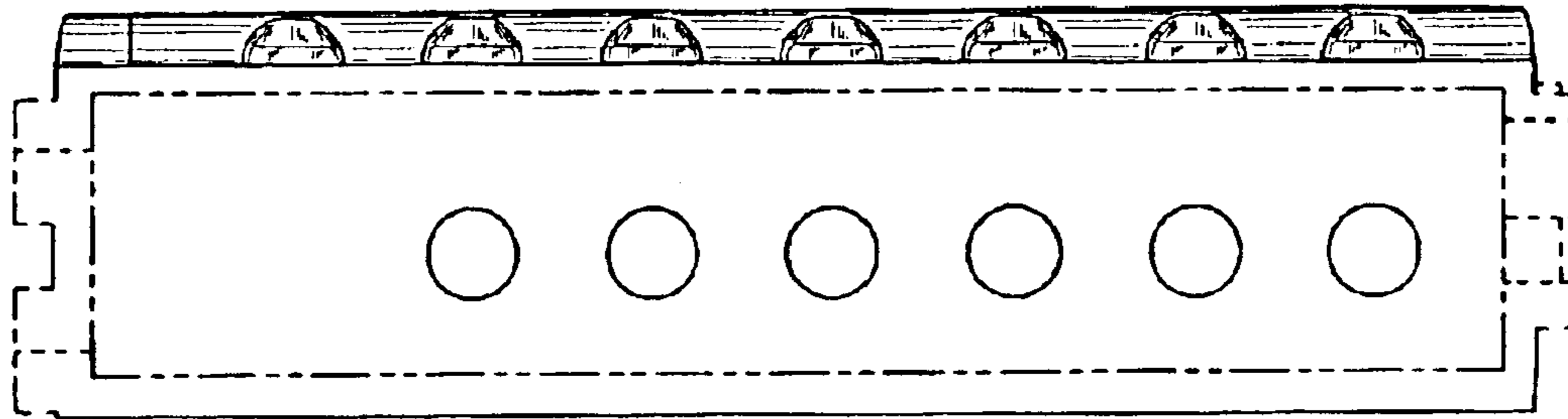

FIG. 23

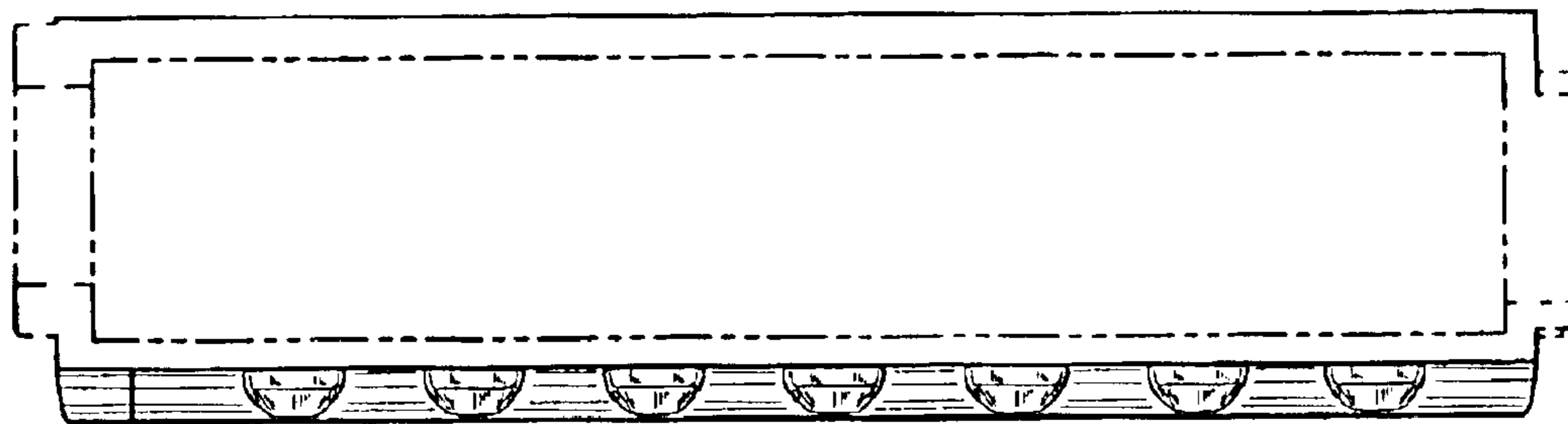

FIG. 24

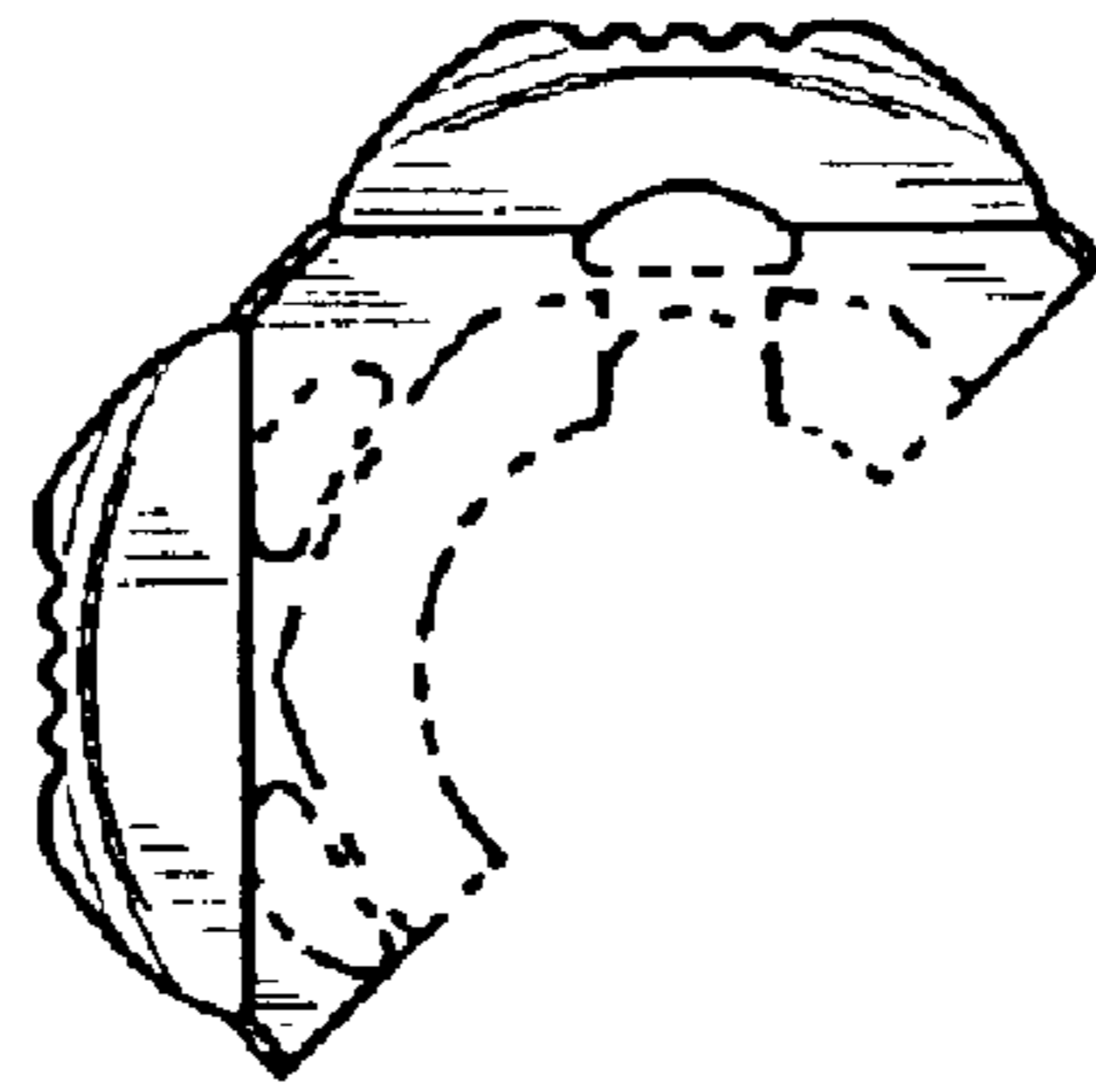

FIG. 25

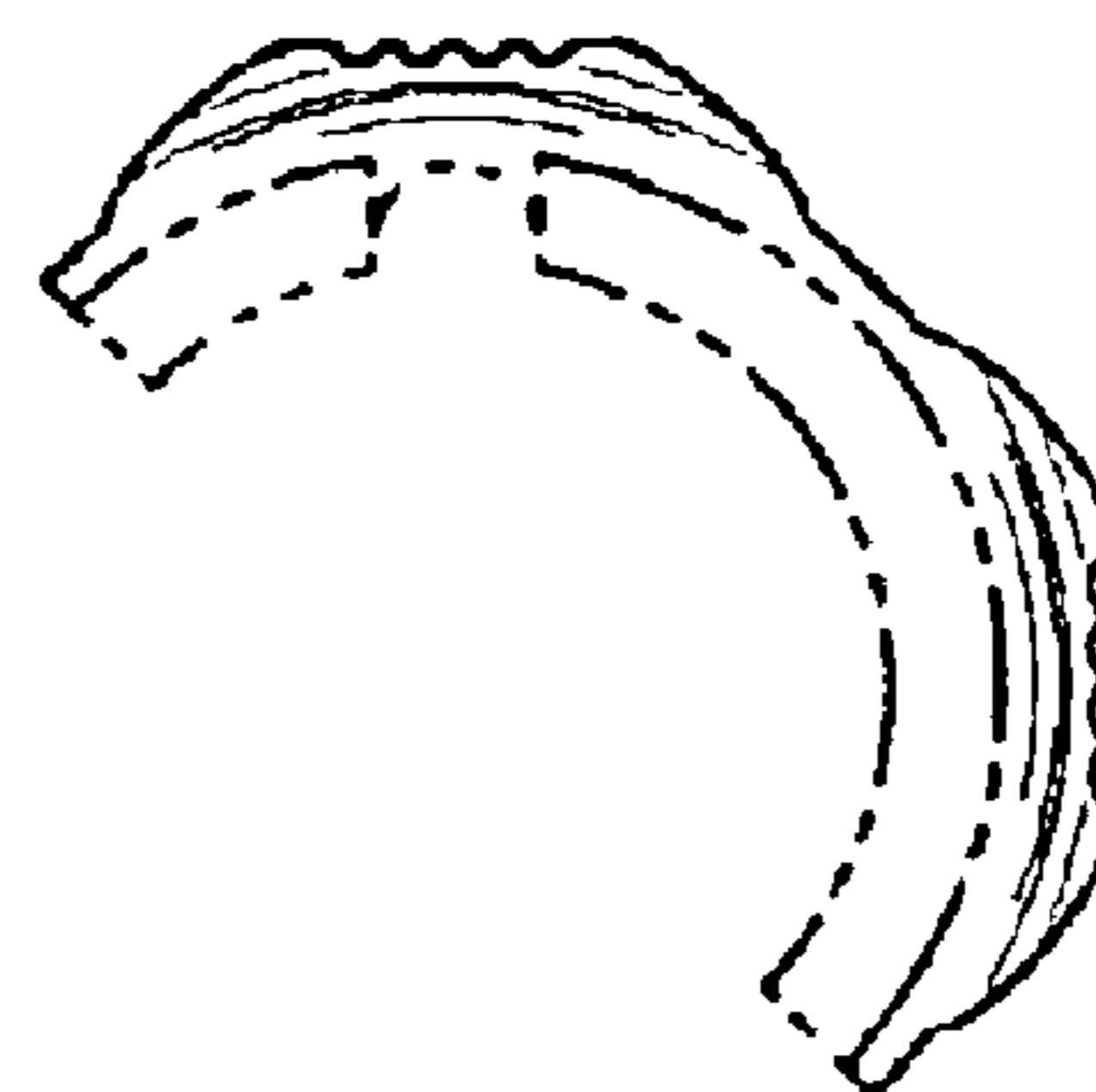

FIG. 26

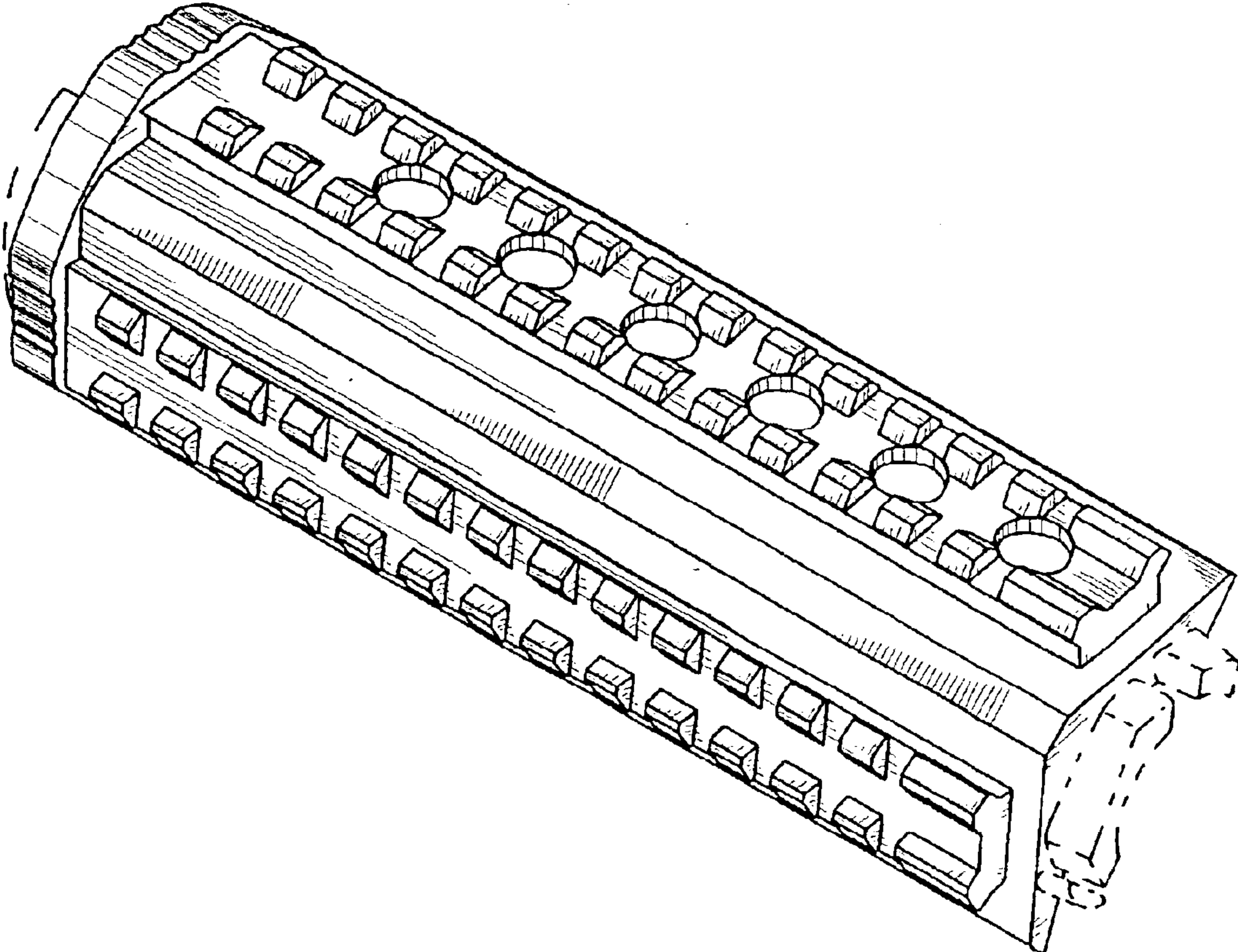

FIG. 27

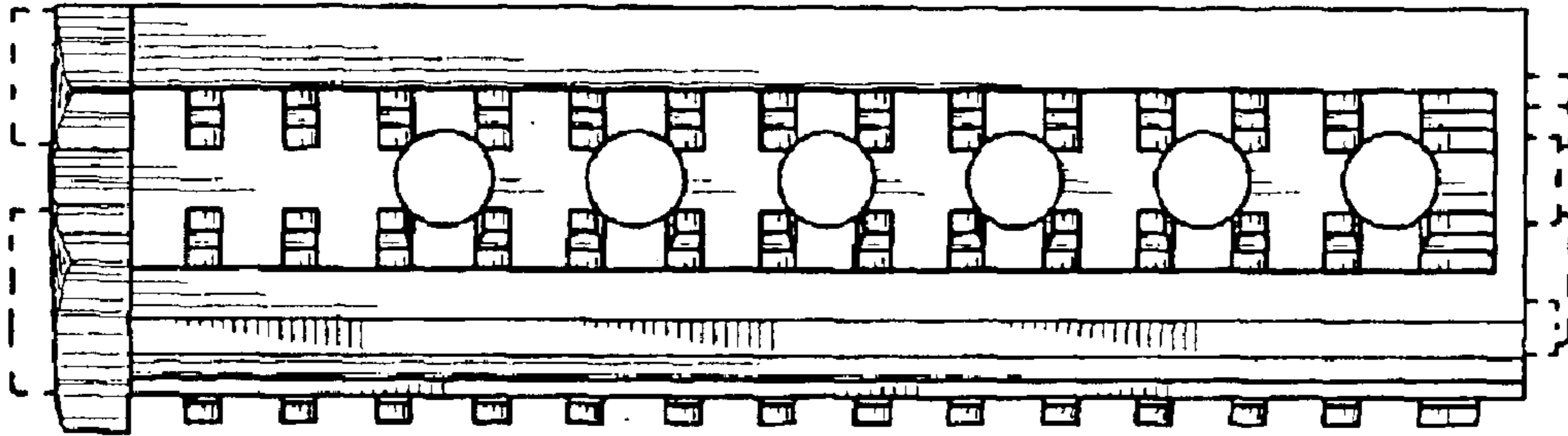

FIG. 28

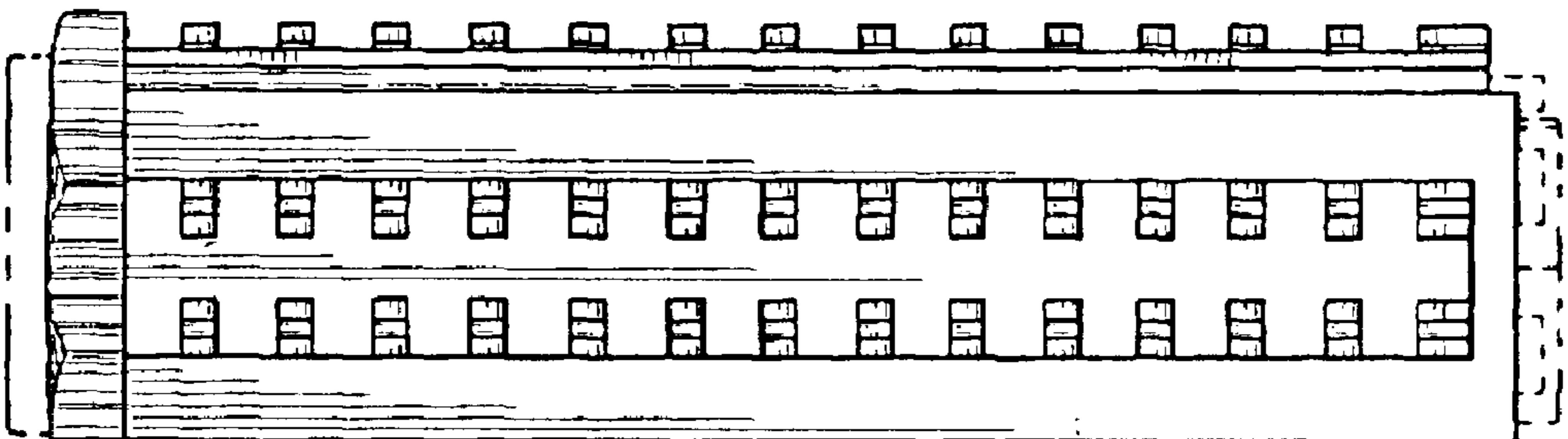

FIG. 29

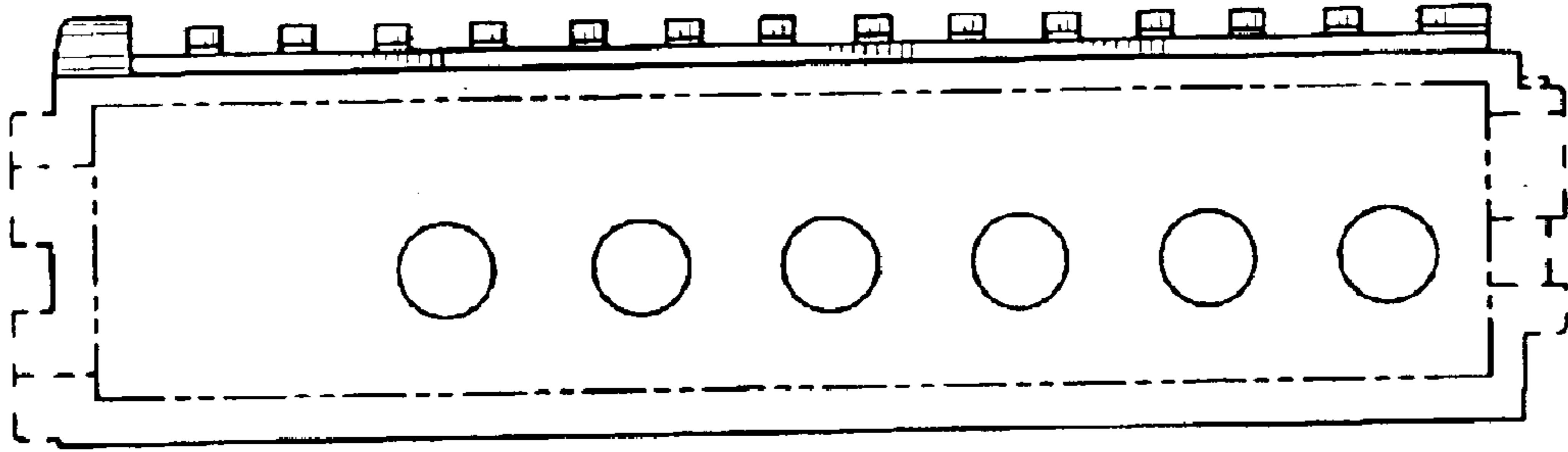

FIG. 30

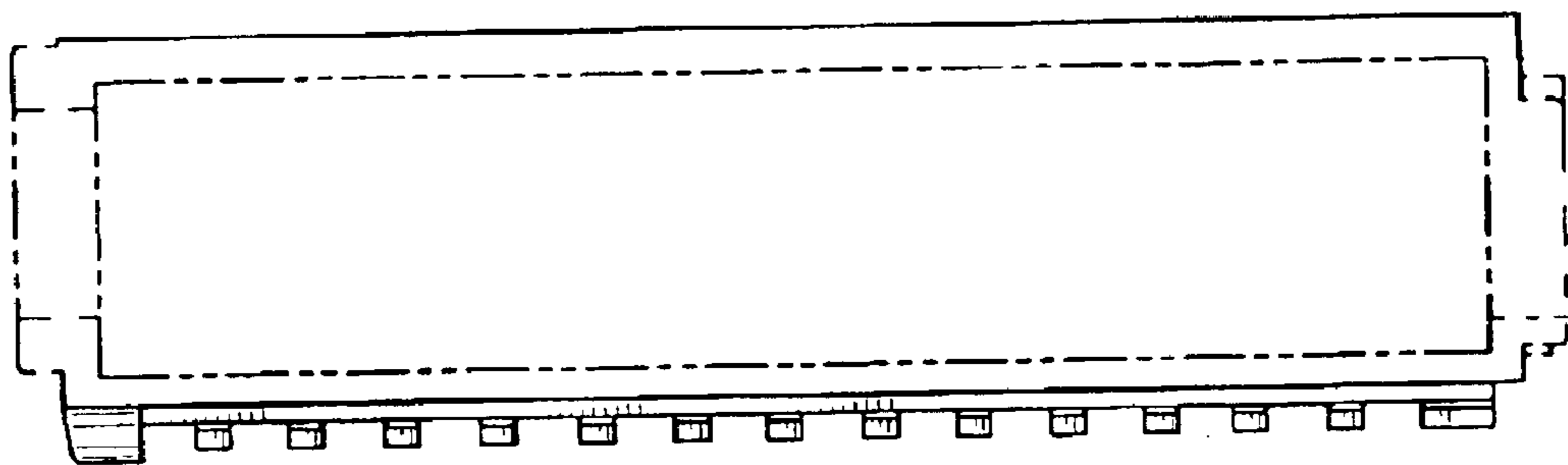

FIG. 31

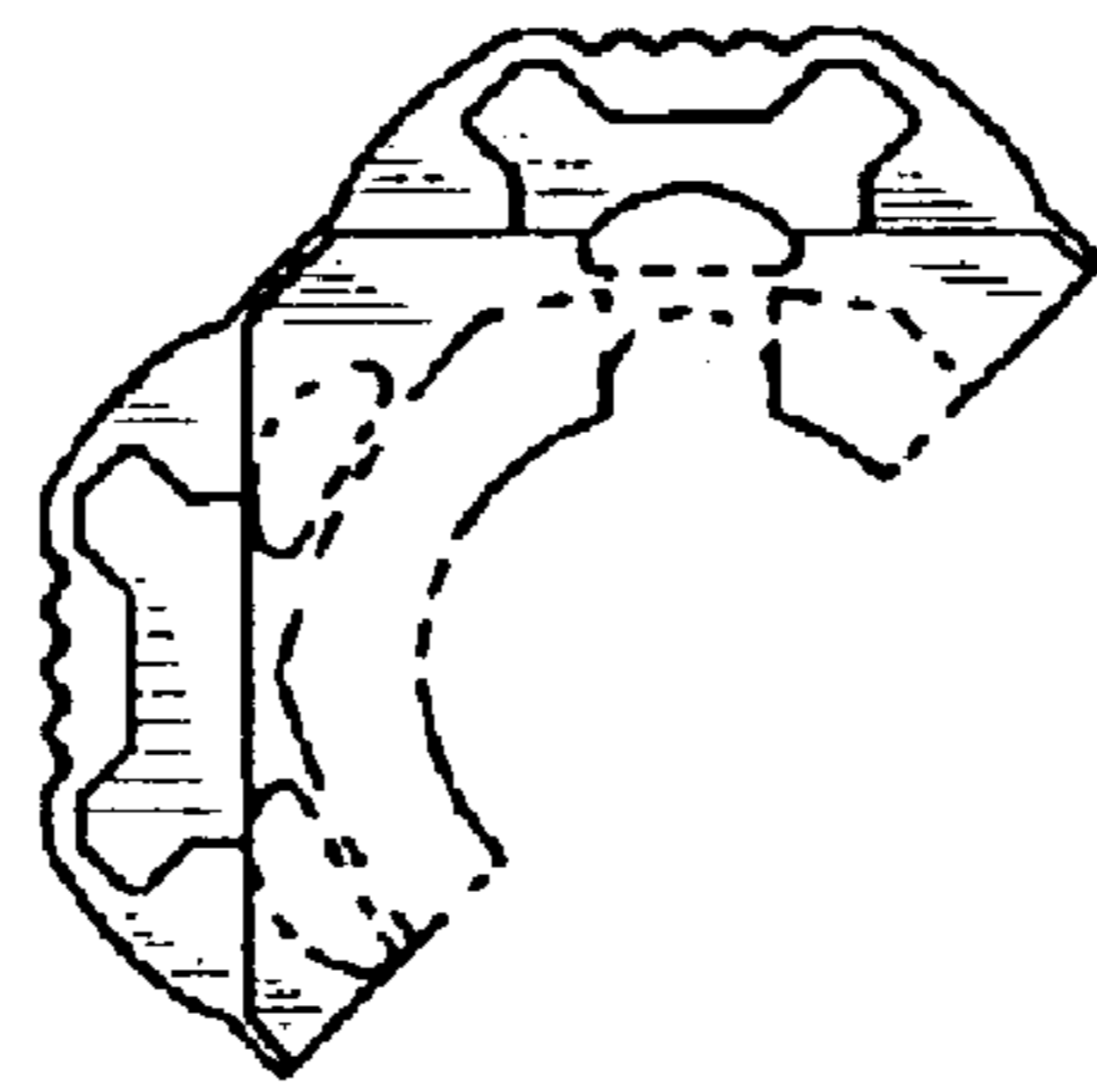

FIG. 32

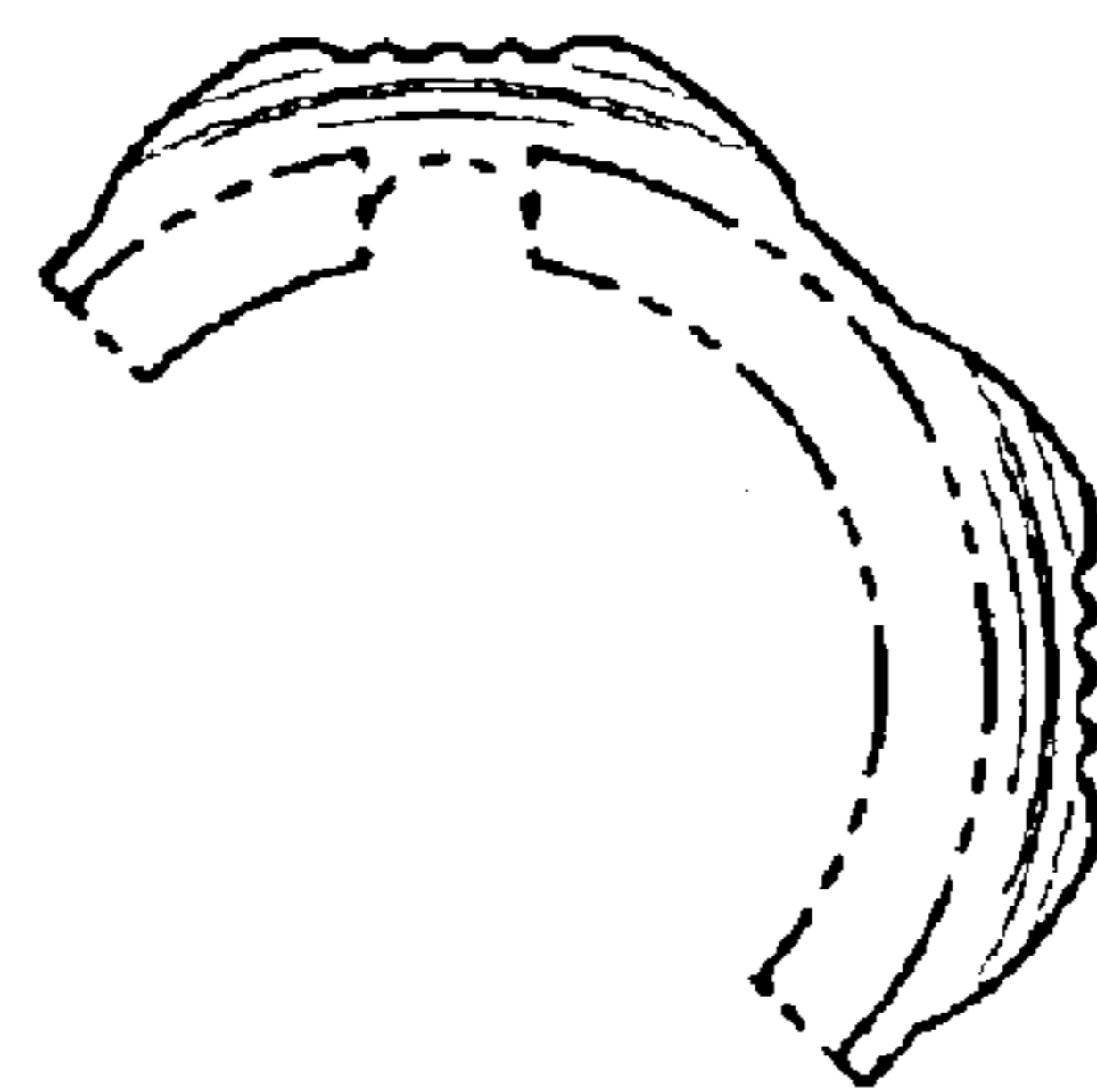

FIG. 33

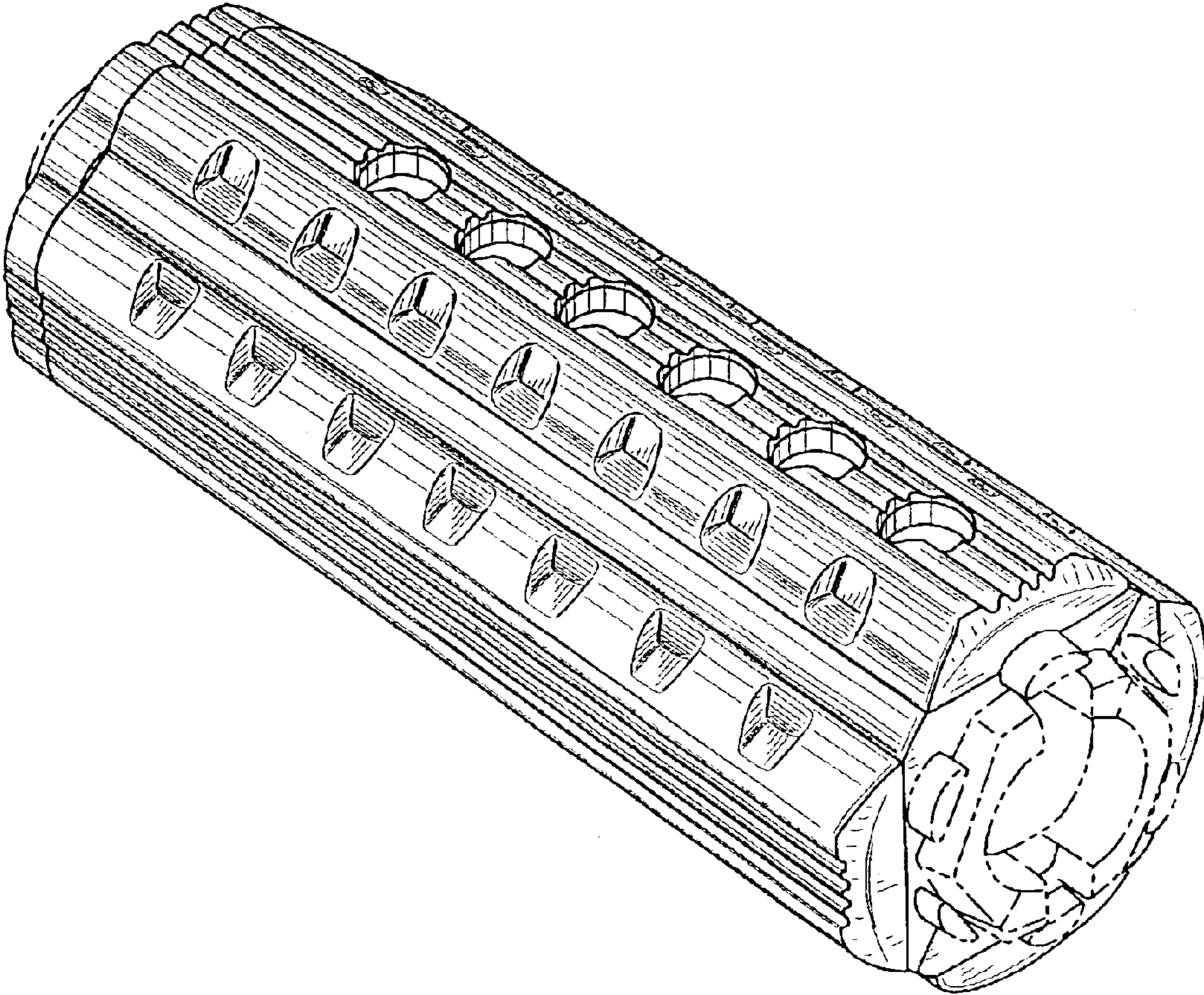

FIG. 34

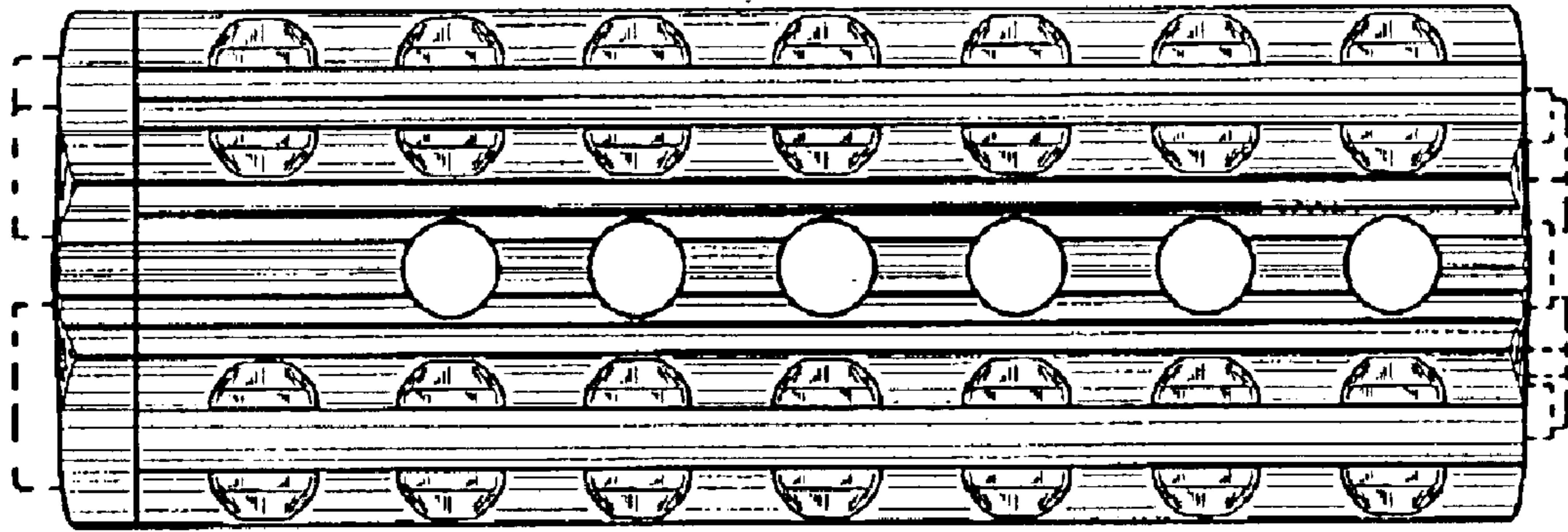

FIG. 35

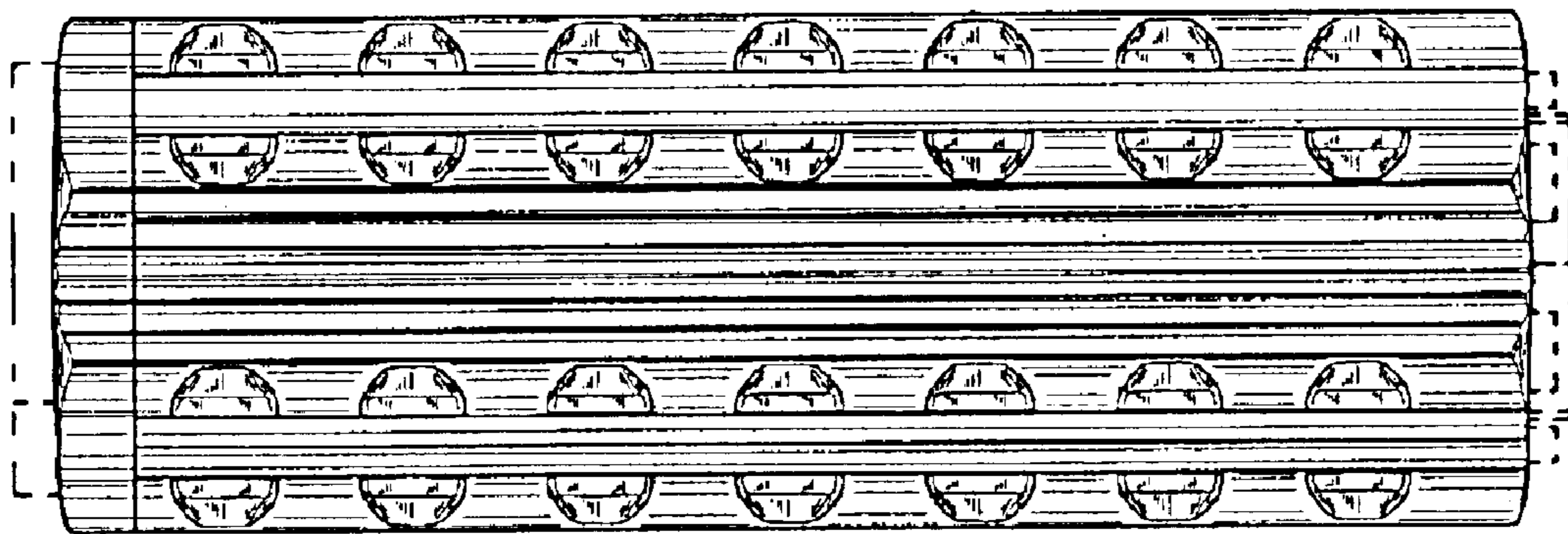

FIG. 36

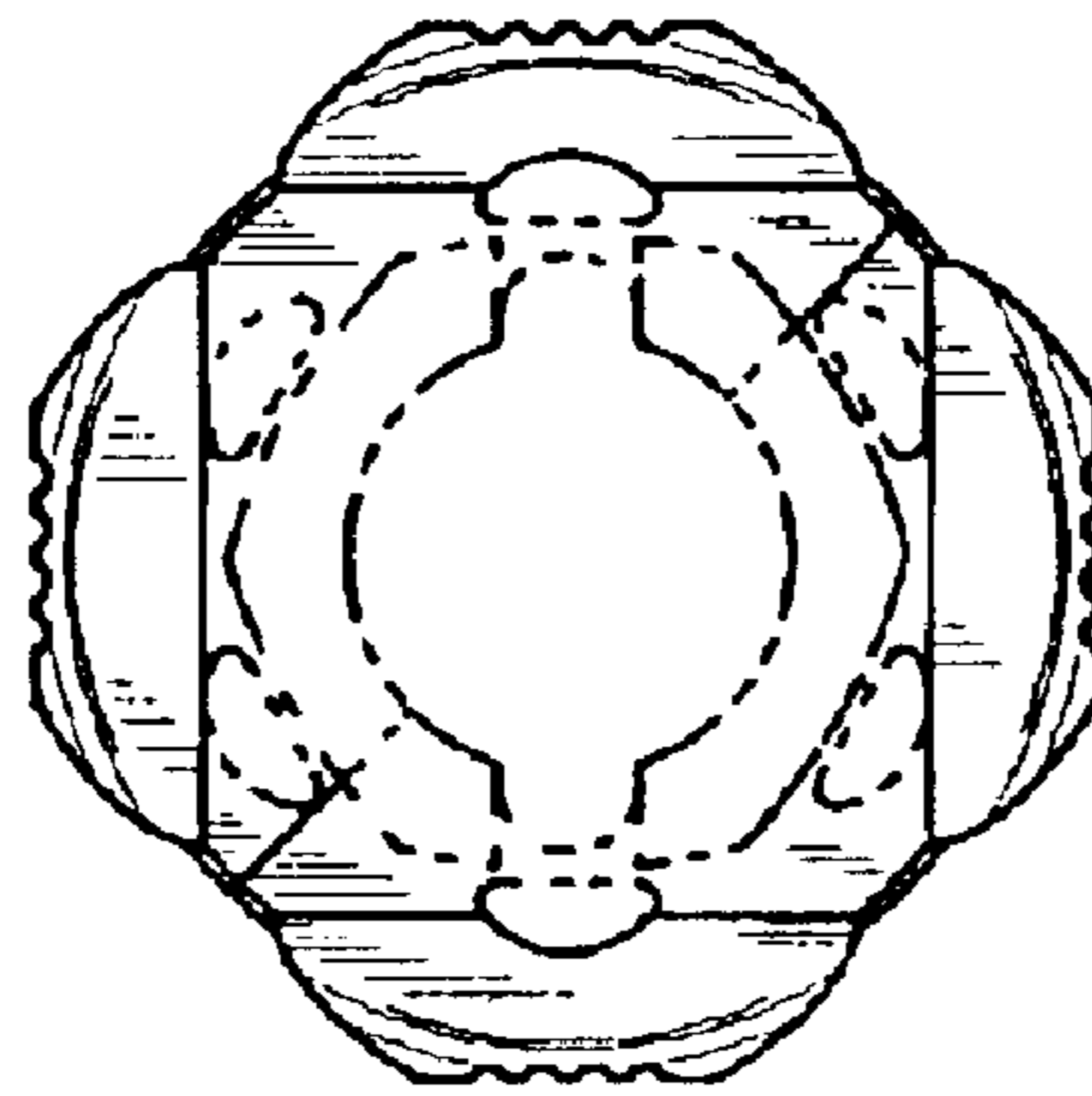

FIG. 37

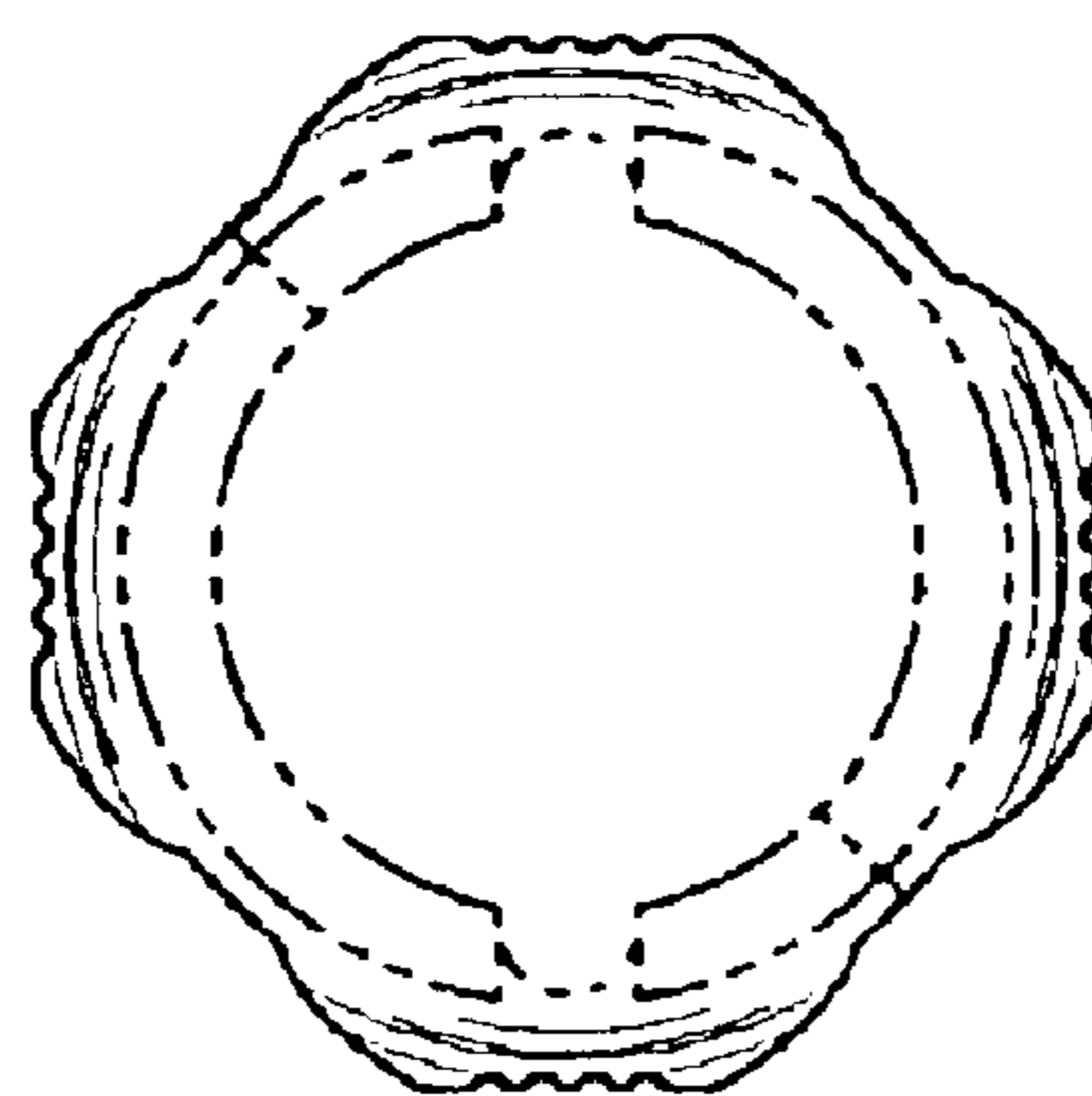

FIG. 38