



US00D507502S

(12) **United States Design Patent**  
**Willnow**

(10) **Patent No.:** **US D507,502 S**  
(45) **Date of Patent:** **\*\* Jul. 19, 2005**

(54) **BATTERY-POWERED VEHICLE WARNING SIGN HAVING ALTERNATING RED AND YELLOW FLASHING TRIANGULARLY SHAPED RIBBON LIGHTS**

D446,465 S \* 8/2001 Sloot ..... D10/109  
6,275,149 B1 \* 8/2001 Tung ..... 340/473  
6,276,080 B1 \* 8/2001 Brennan ..... 40/591  
6,718,670 B2 \* 4/2004 Wang ..... 40/610

(76) Inventor: **Lorin W. Willnow**, 13059 Highway 10,  
Menoken, ND (US) 58558-9735

(\*\*) Term: **14 Years**

(21) Appl. No.: **29/186,501**

(22) Filed: **Jul. 17, 2003**

(51) **LOC (8) Cl.** ..... **10-04**

(52) **U.S. Cl.** ..... **D10/114**

(58) **Field of Search** ..... D10/113, 109;  
116/63 T; 40/586, 903; 340/468, 470, 473;  
D6/300

\* cited by examiner

*Primary Examiner*—Antoine Duval Davis

*Assistant Examiner*—Sydney R. Buffalow

(74) *Attorney, Agent, or Firm*—Donald R. Schoonover

(57) **CLAIM**

I claim the ornamental design for a battery-powered vehicle warning sign having alternating red and yellow flashing triangularly shaped ribbon lights, as shown and described.

**DESCRIPTION**

FIG. 1 is a perspective view of a battery-powered vehicle warning sign having alternating red and yellow flashing triangularly shaped ribbon lights showing my new design; FIG. 2 is a front elevational view thereof; FIG. 3 is a top plan view thereof; FIG. 4 is a bottom plan view thereof; FIG. 5 is a right side elevational view thereof, the left side elevational view being a mirror image thereof; FIG. 6 is a rear elevational view thereof; and, FIG. 7 is a reduced perspective view showing the battery-powered vehicle warning sign having alternating red and yellow flashing triangularly shaped ribbon lights in use along a roadway in solid lines and on a vehicle in dashed lines; the broken lines depict environmental structure for illustrative purposes only and form no part of the claimed design.

(56) **References Cited**

**U.S. PATENT DOCUMENTS**

4,240,220	A	12/1980	Smith	
4,245,888	A	1/1981	Wardecki	
4,806,903	A	2/1989	Rust	
D314,161	S	* 1/1991	Kondo	..... D10/114
4,994,786	A	2/1991	Schaffer	
D323,303	S	* 1/1992	Johansson et al.	..... D10/114
5,323,728	A	* 6/1994	Hjelm	..... 116/63 T
5,397,617	A	3/1995	Chen	
D383,080	S	* 9/1997	Derrick	..... D10/109
5,764,141	A	6/1998	Chang	
5,838,260	A	11/1998	Liu	
D401,878	S	* 12/1998	Evanyk	..... D10/109
6,215,200	B1	4/2001	Genzel	

**1 Claim, 3 Drawing Sheets**

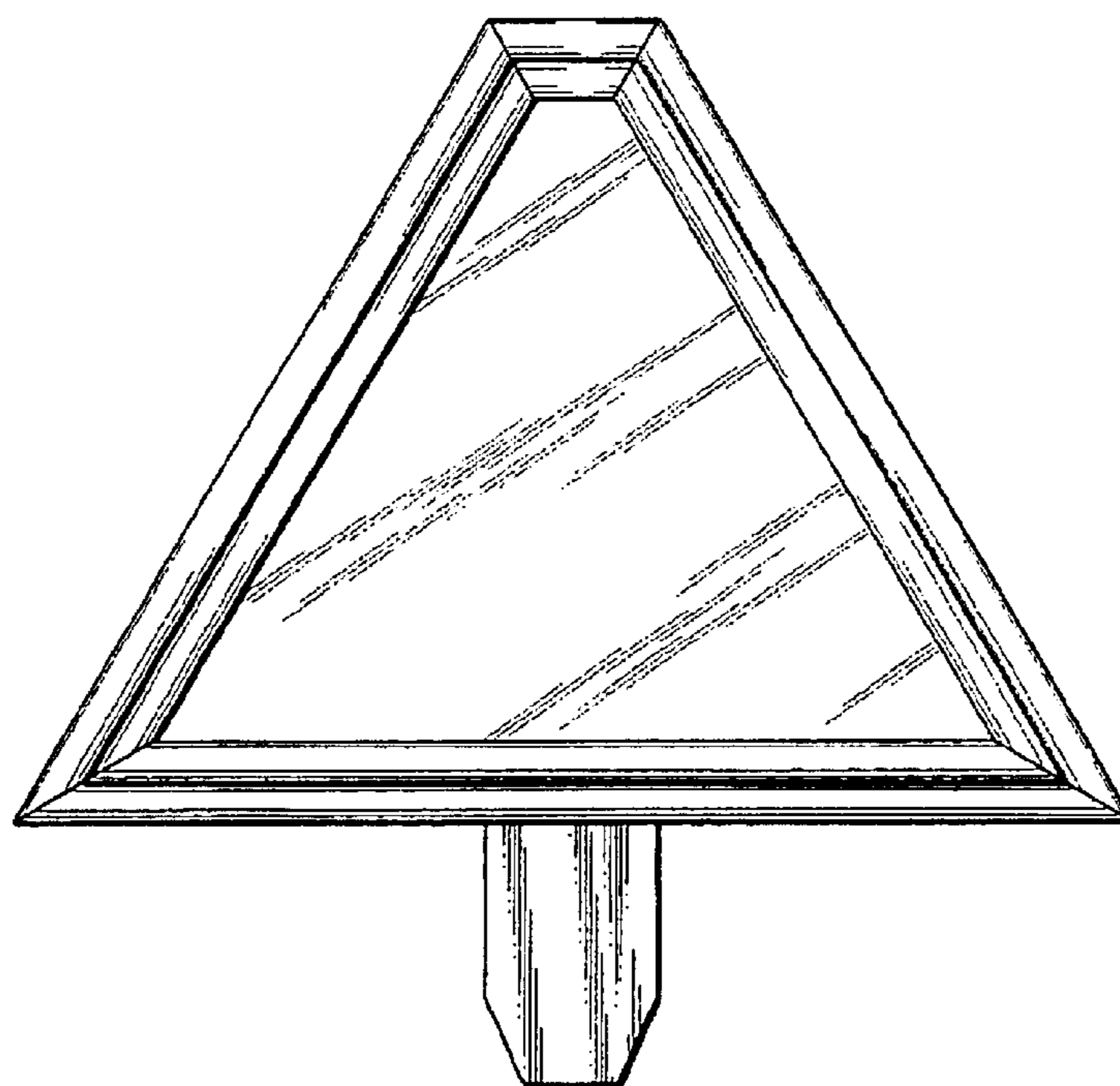

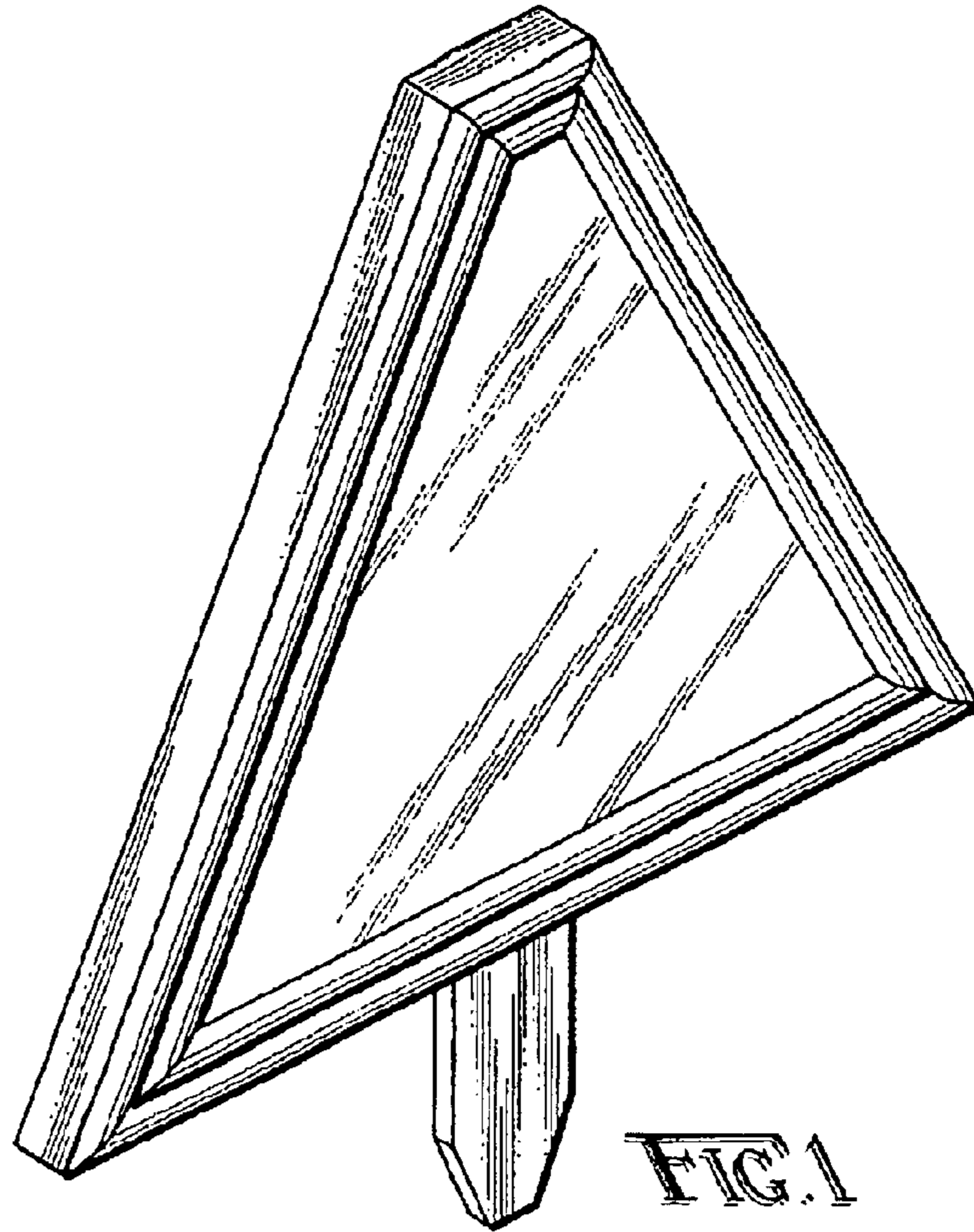

FIG. 1

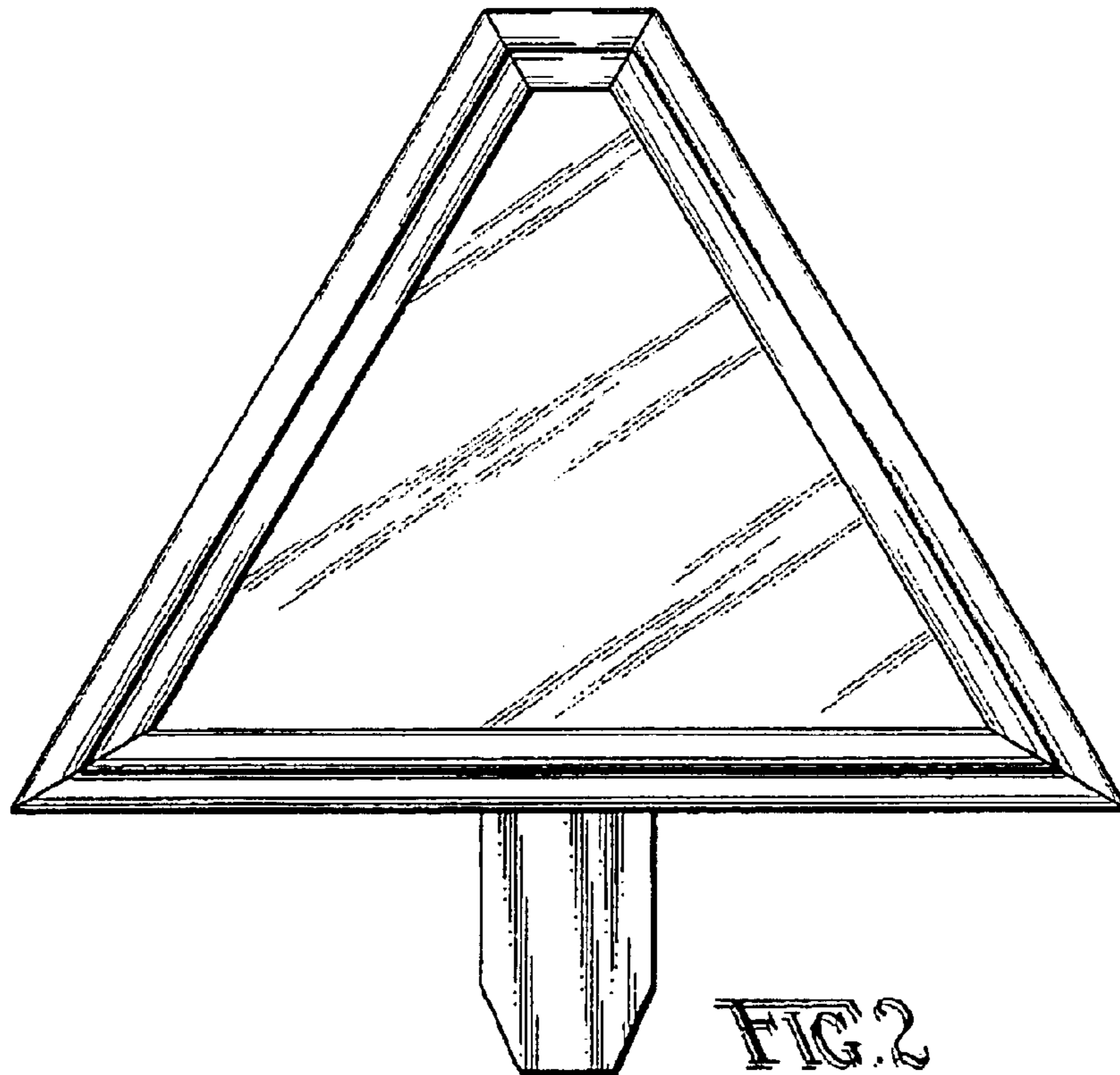

FIG. 2



FIG. 3



FIG. 4



FIG. 5

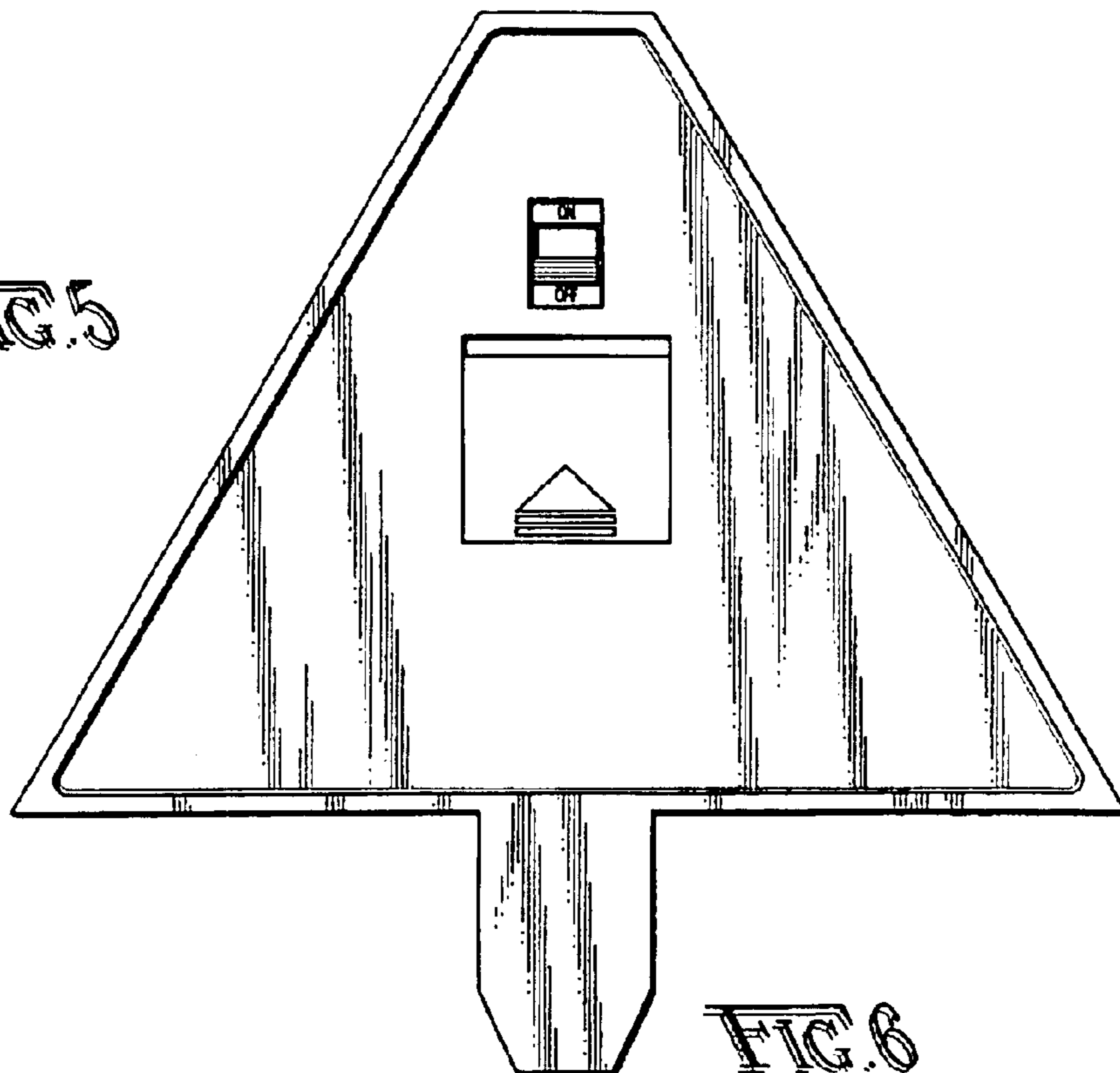

FIG. 6

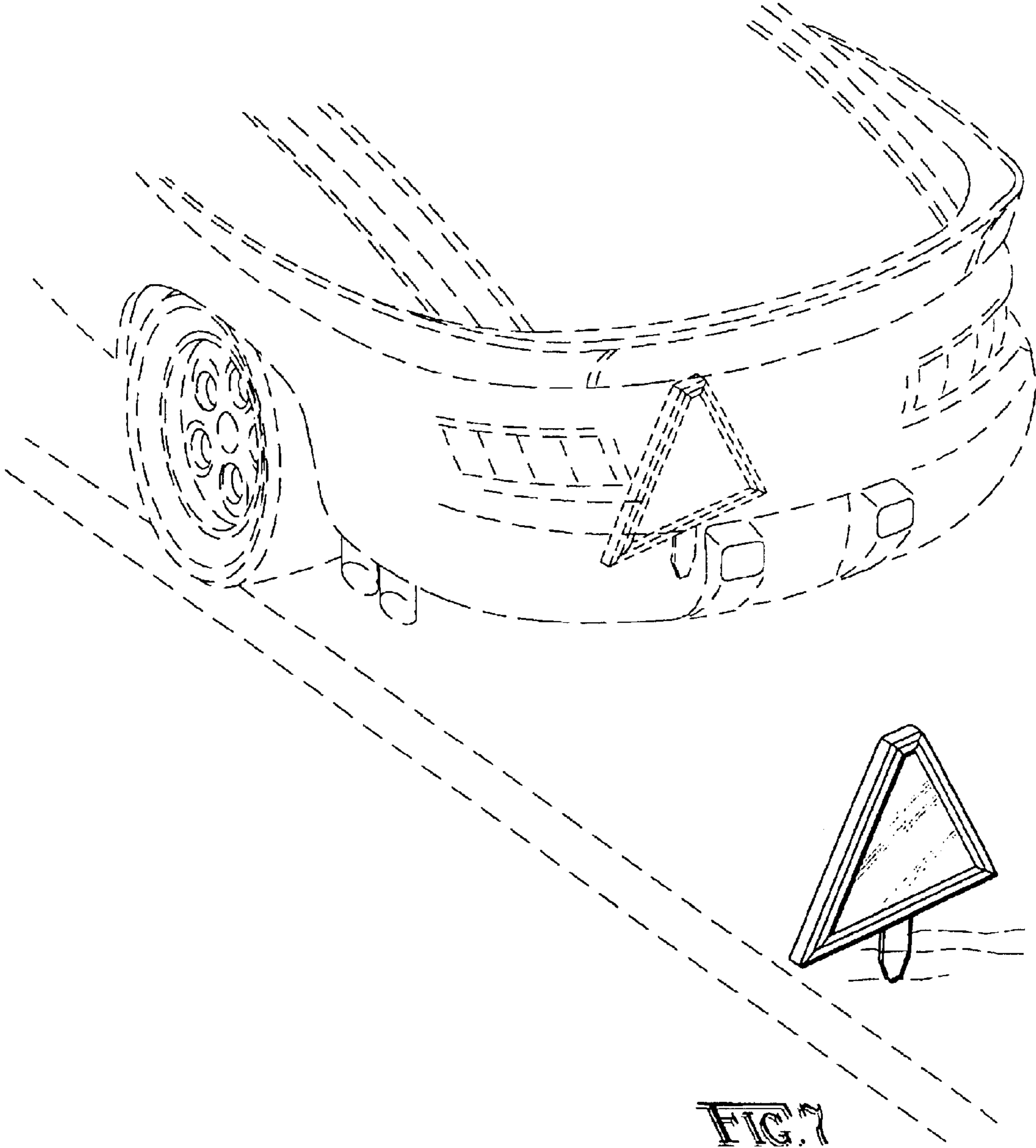

FIG. 7