

US00D507405S

(12) **United States Design Patent**
Kim et al.

(10) **Patent No.:** **US D507,405 S**
(45) **Date of Patent:** **** Jul. 19, 2005**

(54) **ERGONOMIC LUGGAGE HANDLE**

D422,409 S 4/2000 Klenner et al.

(75) Inventors: **Daniel Kim**, Appleton, WI (US); **Doug Golenz**, Louisville, CO (US)

(Continued)

(73) Assignee: **JanSport Apparel Corp.**, Wilmington, DE (US)

Primary Examiner—Louis S. Zarfaz
Assistant Examiner—Monica A. Weingart
(74) *Attorney, Agent, or Firm*—Arnold & Porter LLP;
Marcia H. Sundeen

(**) Term: **14 Years**

(57) **CLAIM**

(21) Appl. No.: **29/197,306**

The ornamental design for an ergonomic luggage handle, as shown and described.

(22) Filed: **Jan. 14, 2004**

DESCRIPTION

(51) **LOC (8) Cl.** **03-01**

(52) **U.S. Cl.** **D3/318**

(58) **Field of Search** D3/279, 282, 318,
D3/328, 324; D8/302, 306, 316, 317, 319,
320; D34/24, 26; 190/18 A, 39, 102, 103,
111, 115; 280/37, 47.26, 655, 655.1; 16/110.1,
113.1, 114.1, 405, 406, 408, 445, 421,
422, 429, 430, 431

FIG. 1 is a perspective view of the front of an ergonomic luggage handle of the invention, showing our new design in the context of a piece of luggage with the handle in the down position.

FIG. 2 is a front view of the ergonomic luggage handle of the invention.

FIG. 3 is a side view of the ergonomic luggage handle of the invention.

FIG. 4 is a top view of the ergonomic luggage handle of the invention.

FIG. 5 is a bottom view of the ergonomic luggage handle of the invention.

FIG. 6 is a perspective view of the front of an ergonomic luggage handle of the invention, showing our new design in the context of a piece of luggage with the handle in the up position, parallel to the ground.

FIG. 7 is a perspective view of the front of an ergonomic luggage handle of the invention, showing our new design in the context of a piece of luggage with the handle in the fully up position, perpendicular to the ground; and,

FIG. 8 is a perspective view of the front of an ergonomic luggage handle of the invention, showing our new design in the context of a piece of luggage with the handle in the down position and stored within the luggage.

The broken line showing of a suitcase and towing member in FIGS. 1–3, and 6–8, is for illustrative purposes only and forms no part of the claimed design.

(56) **References Cited**

U.S. PATENT DOCUMENTS

1,278,552 A	9/1918	Allmand
3,805,929 A	4/1974	Kuwayama
4,561,526 A	12/1985	Winter et al.
4,928,800 A	5/1990	Green et al.
5,075,925 A	12/1991	Maloney
5,253,739 A	10/1993	King
D352,826 S	11/1994	Rao
5,447,261 A	9/1995	Mitomi et al.
5,533,601 A	7/1996	Wang
D373,246 S	9/1996	Stokes et al.
5,560,458 A	10/1996	Franklin et al.
5,566,797 A	10/1996	Van Himbeeck
5,588,569 A	12/1996	Mitomi et al.
D383,603 S	9/1997	Pedlar
D383,905 S	9/1997	Stokes et al.
5,762,169 A	6/1998	Deliman et al.
5,813,504 A	9/1998	Iny et al.
5,924,533 A	7/1999	Cnockaert et al.
5,943,936 A	8/1999	Deliman et al.
6,032,771 A	3/2000	Pedrini

1 Claim, 6 Drawing Sheets

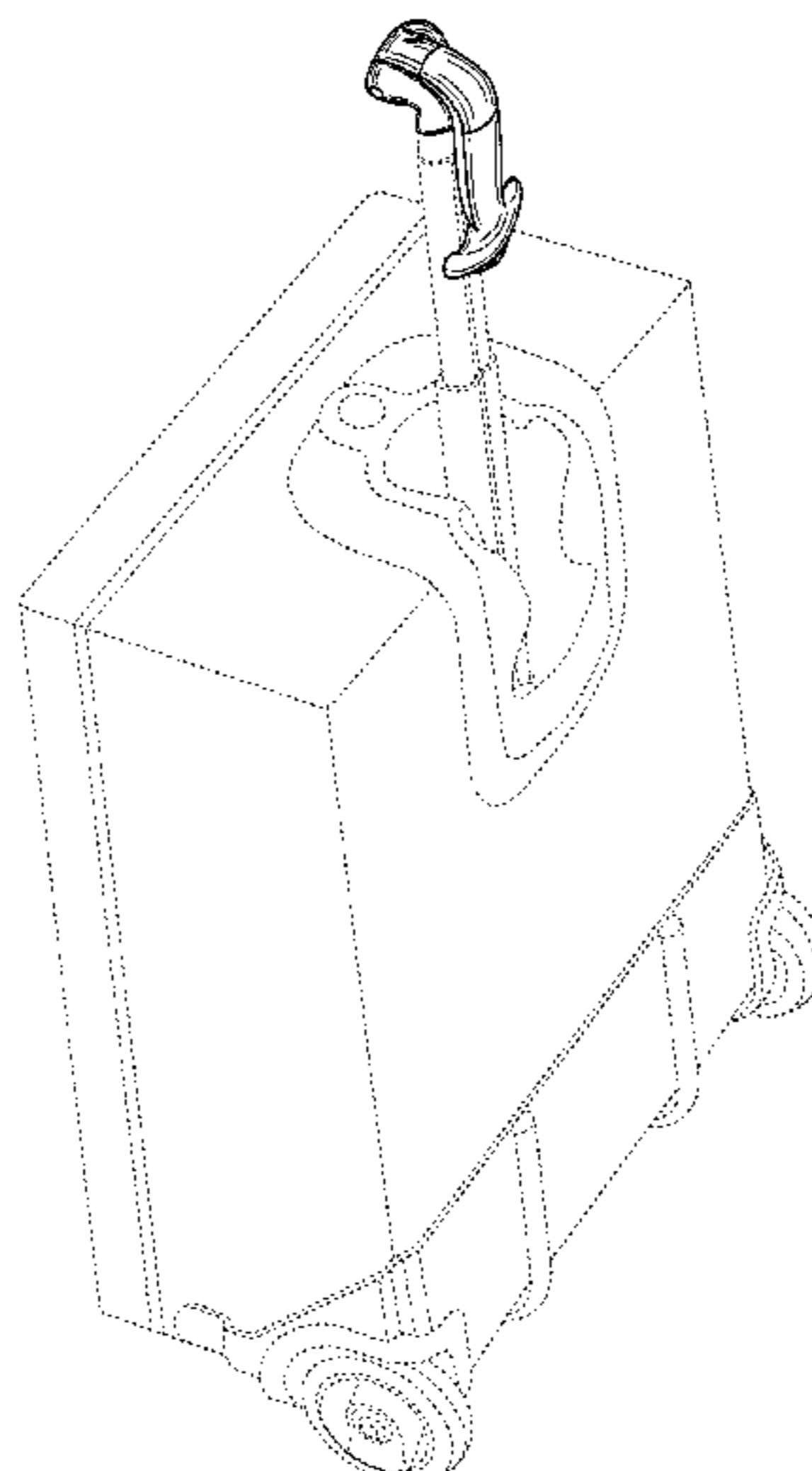

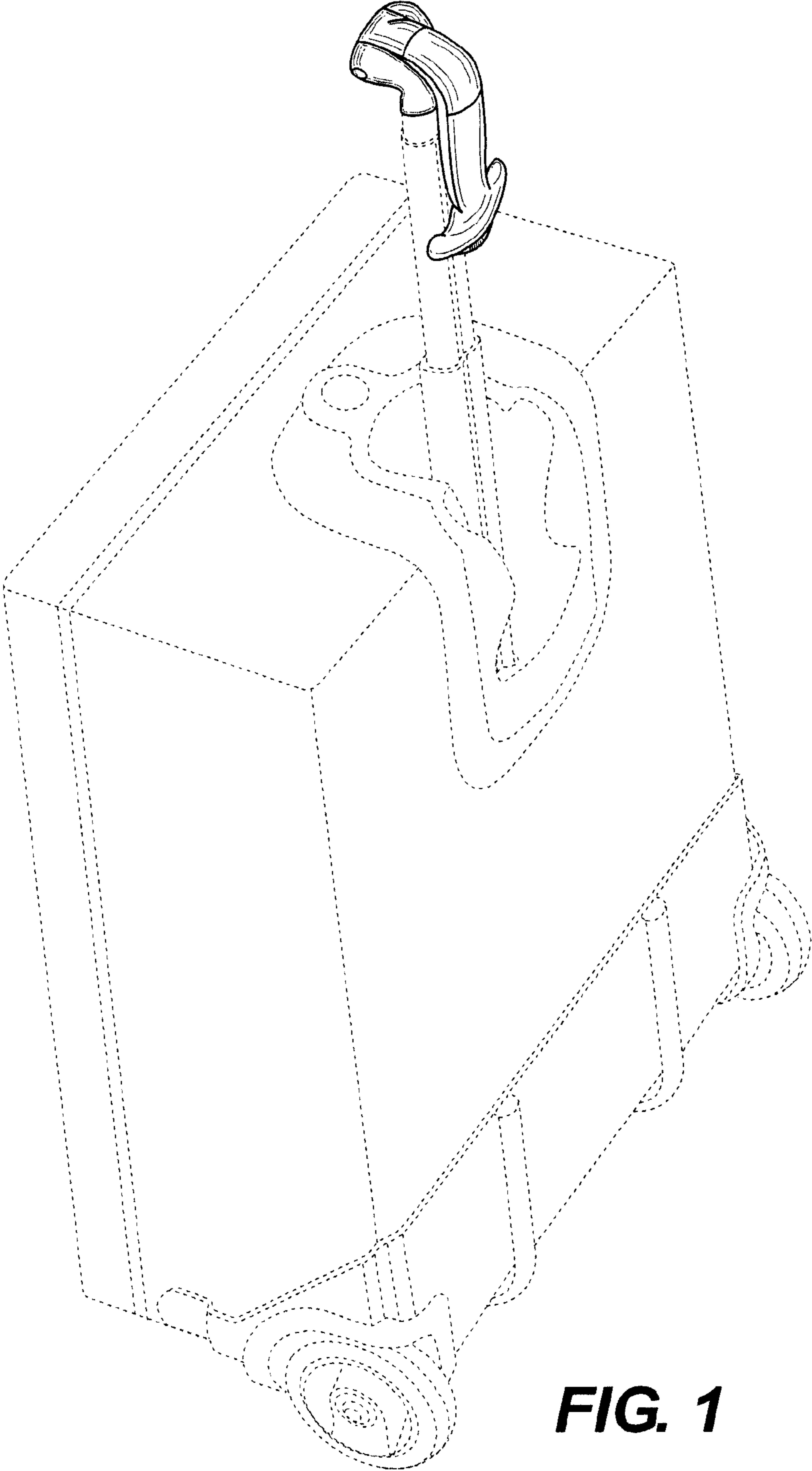

FIG. 1

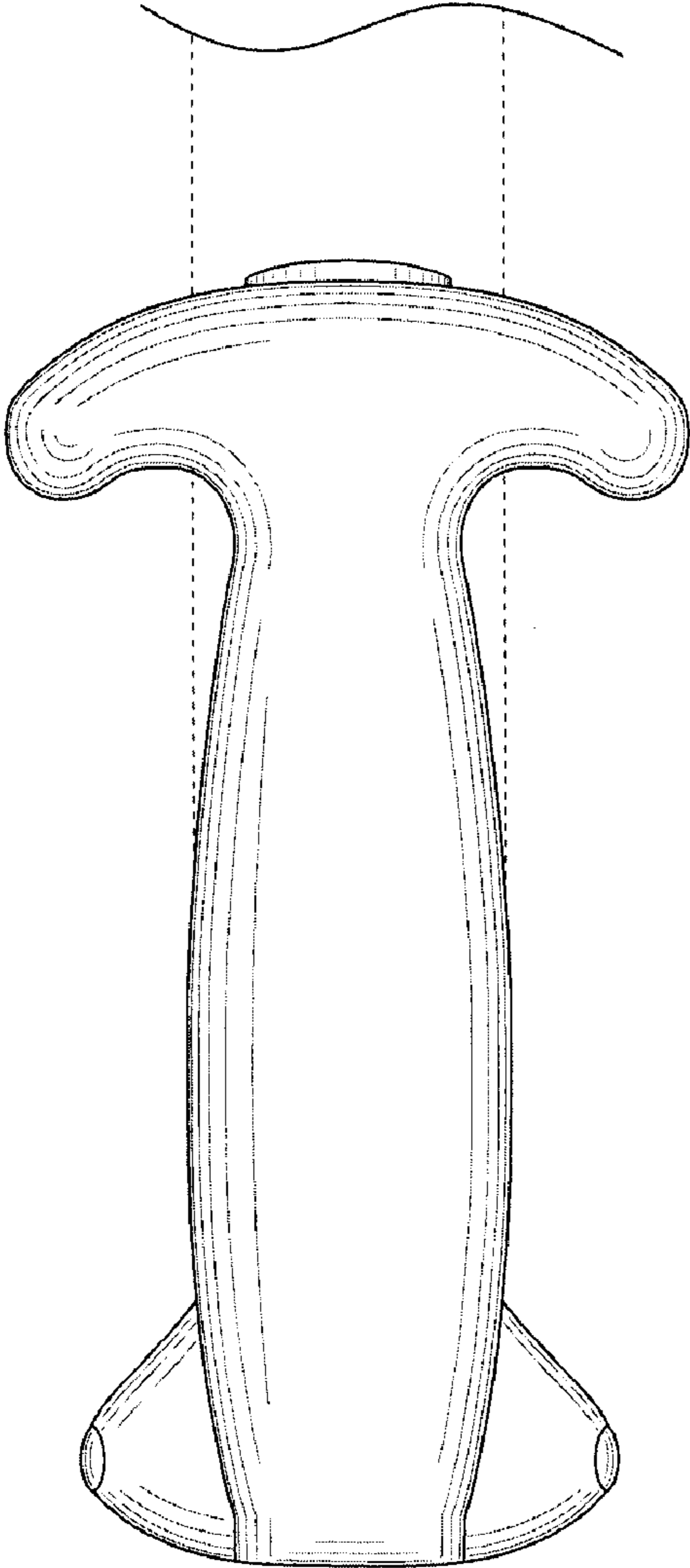

FIG. 2

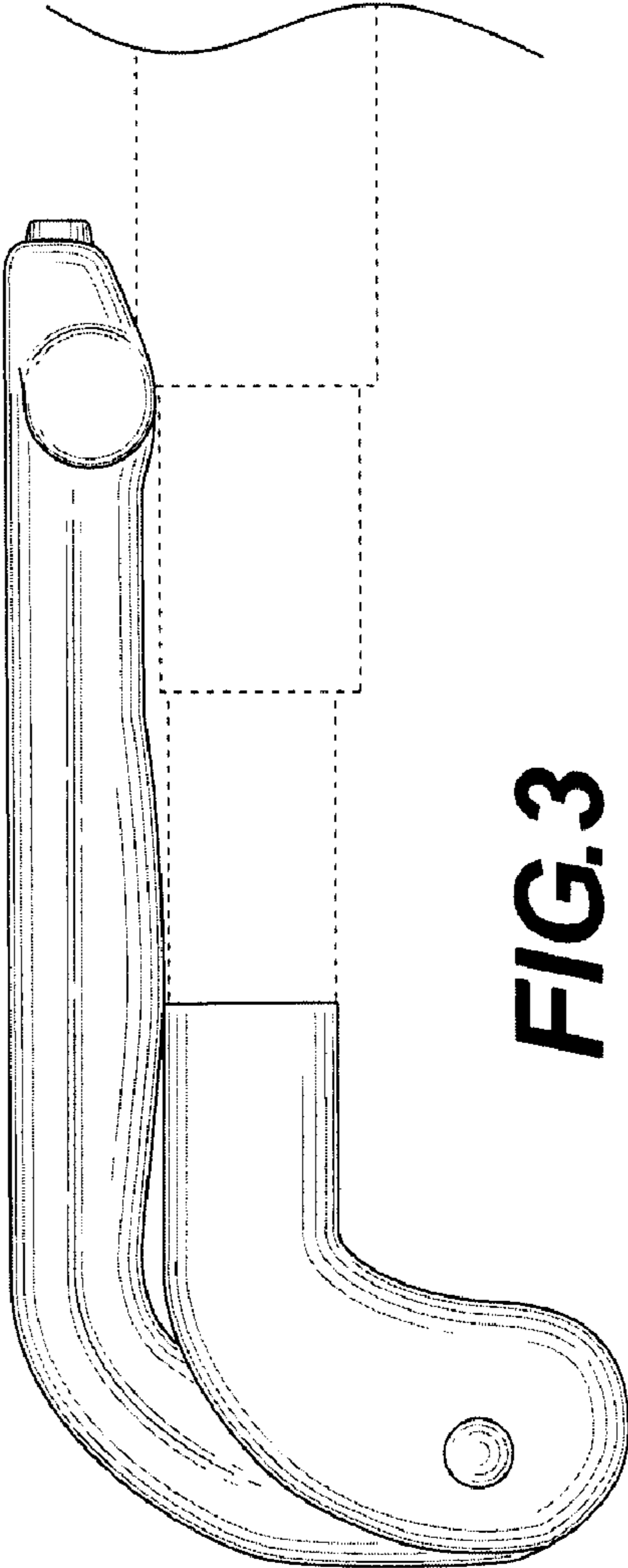

FIG. 3

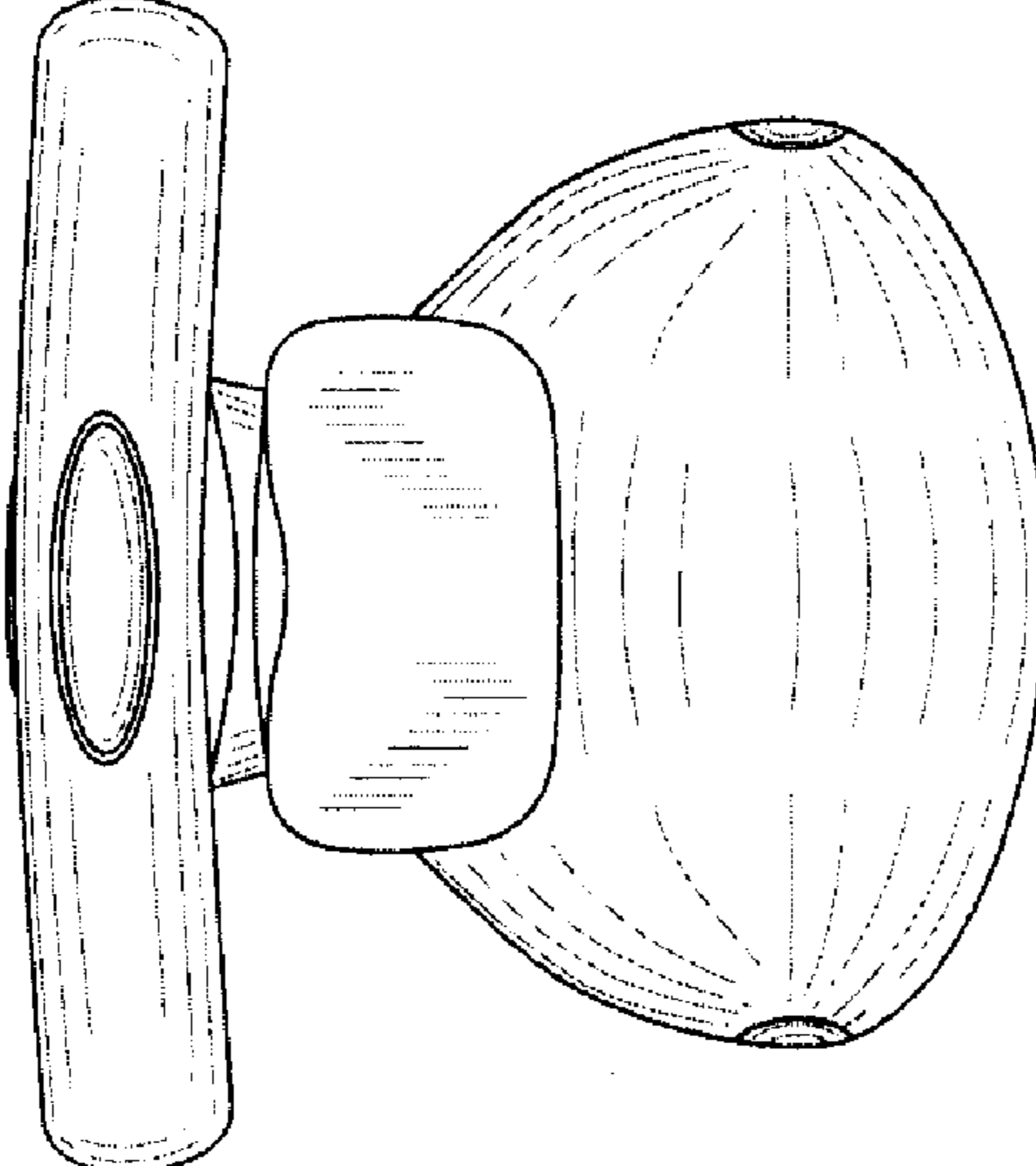

FIG. 5

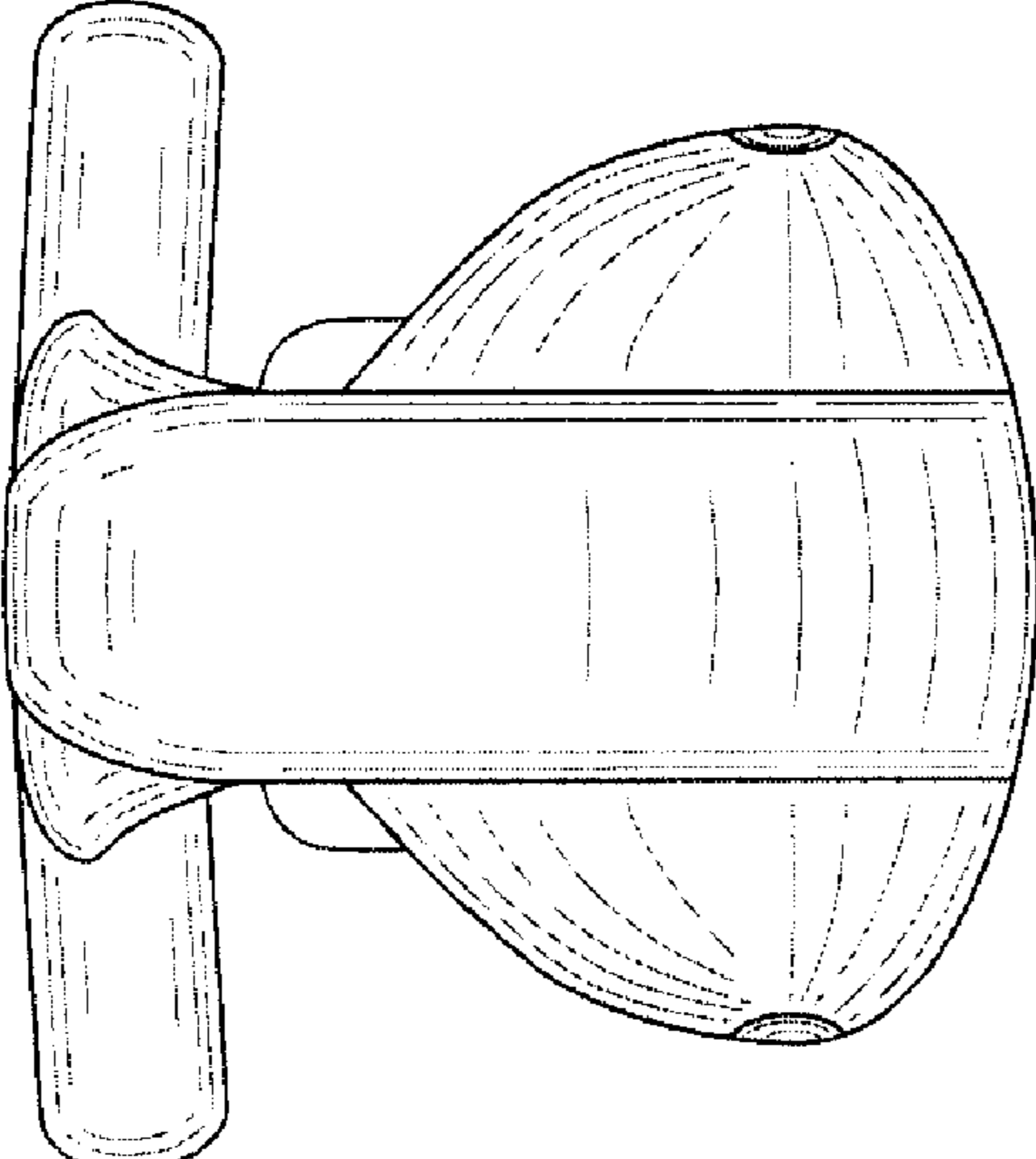

FIG. 4

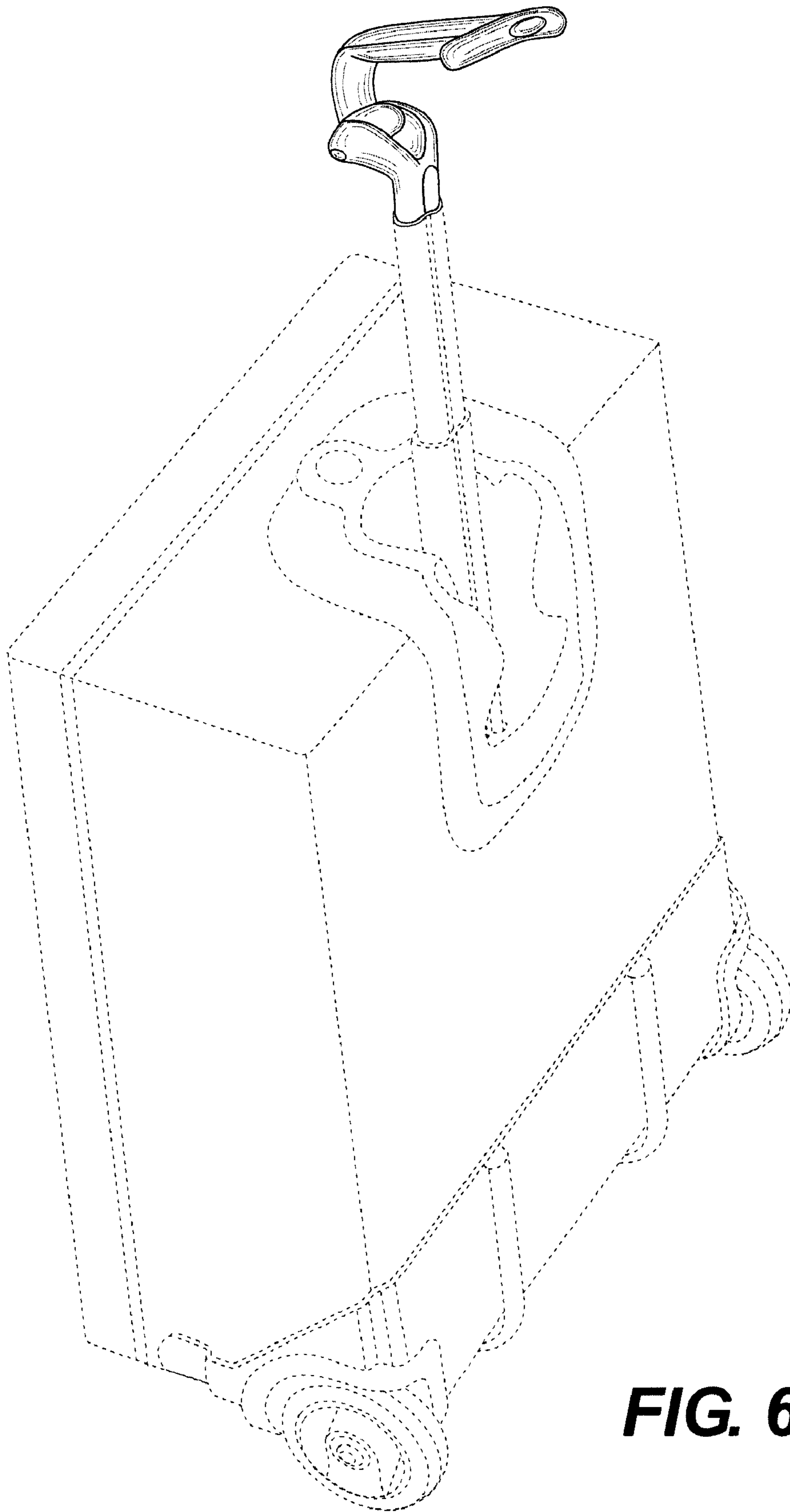

FIG. 6

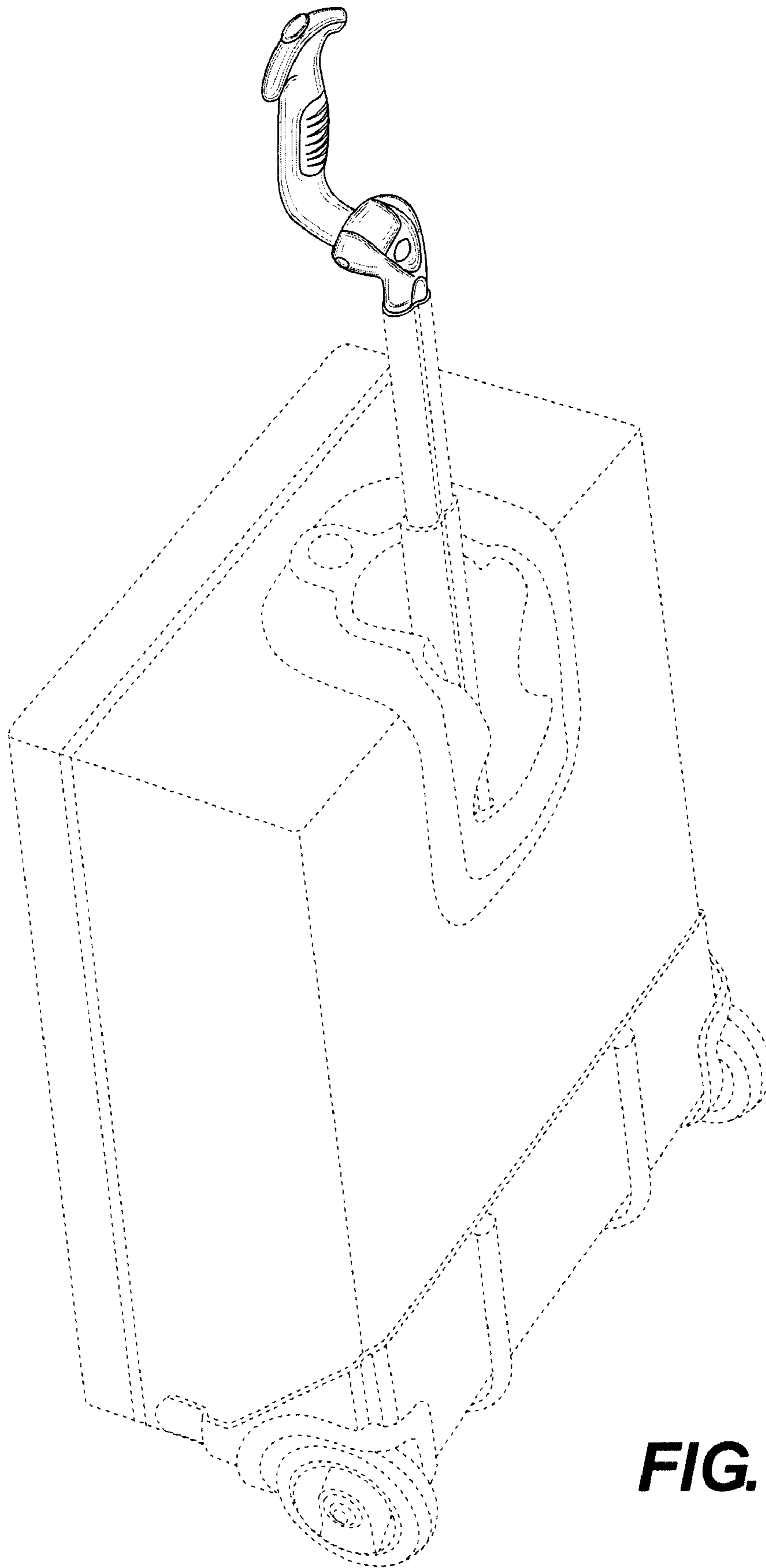

FIG. 7

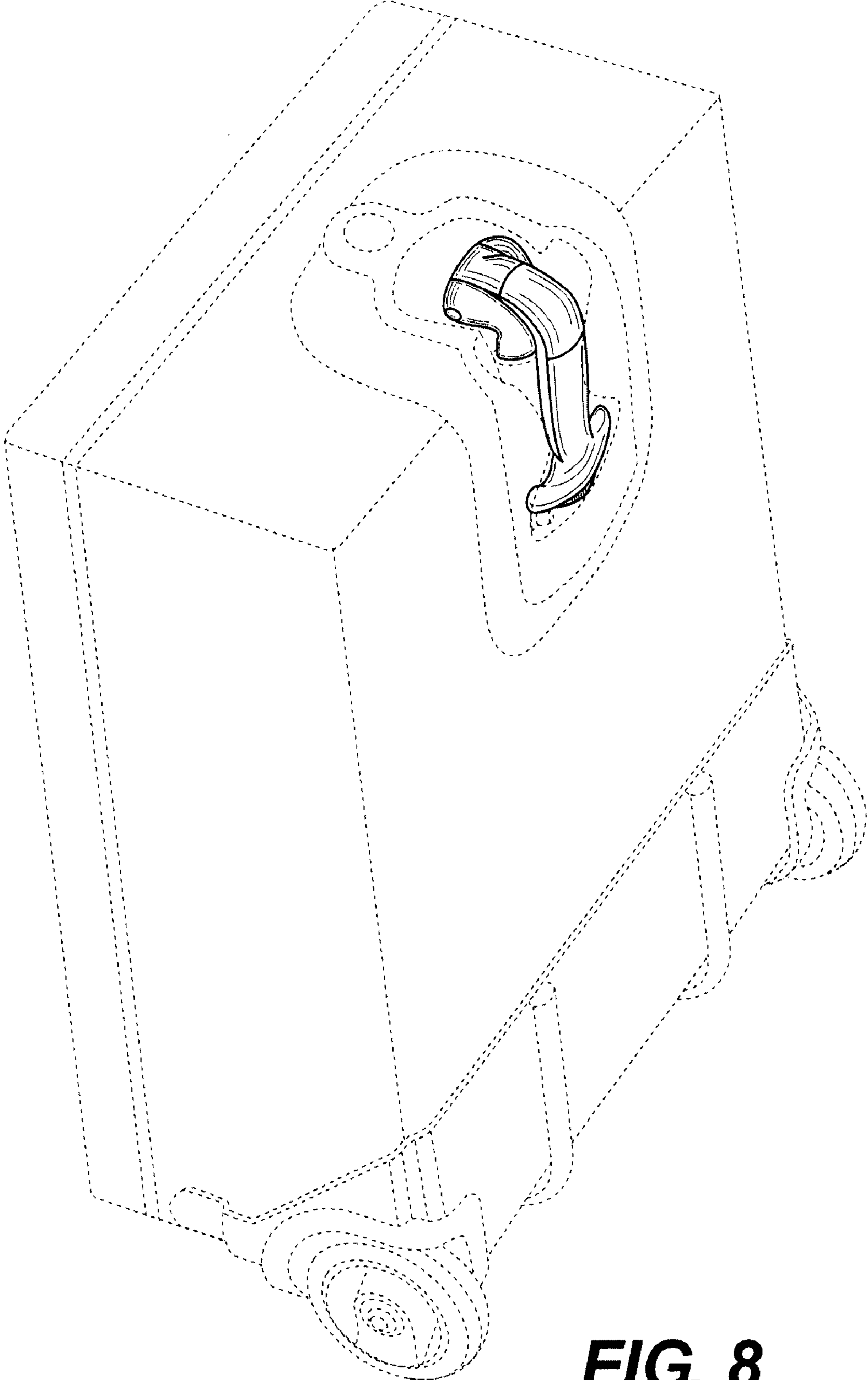

FIG. 8