

US00D507355S

(12) **United States Design Patent**  
**Fischer**

(10) **Patent No.:** **US D507,355 S**  
(45) **Date of Patent:** **\*\* Jul. 12, 2005**

(54) **SLATWALL EXTRUSION**

(76) **Inventor:** **James R. Fischer**, 1717 Twin Oaks  
La., Sheboygan, WI (US) 63083

(\*\*) **Term:** **14 Years**

(21) **Appl. No.:** **29/200,781**

(22) **Filed:** **Mar. 4, 2004**

**Related U.S. Application Data**

(63) Continuation-in-part of application No. 29/194,172, filed on  
Nov. 20, 2003.

(51) **LOC (8) Cl.** ..... **25-01**

(52) **U.S. Cl.** ..... **D25/122**

(58) **Field of Search** ..... 52/36.4, 36.5,  
52/36.6; 211/94.01, 94.02, 87.01; D25/122

(56) **References Cited**

**U.S. PATENT DOCUMENTS**

D393,907 S	*	4/1998	Current	.....	D25/122
D400,270 S		10/1998	Current	.....	D25/123
5,819,490 A		10/1998	Current	.....	52/588.1
D403,085 S		12/1998	Current	.....	D25/123
5,899,344 A		5/1999	Current et al.	.....	211/94.01
6,659,295 B1	*	12/2003	De Land et al.	.....	211/187

**OTHER PUBLICATIONS**

“Tooling Triad,” Gardner Publications, Inc., reprint of Sep.  
2001 Modern Machine Shop Magazine article.

“Slatwall Systems” brochure, Jifram Extrusions, Inc., 2000.

“Extrusion and Fabrication Tooling” brochure, CPC Tooling  
Technologies, published prior to Dec. 15, 2002.

\* cited by examiner

*Primary Examiner*—Doris Clark

(74) *Attorney, Agent, or Firm*—Andrus, Scales, Starke &  
Sawall, LLP

(57) **CLAIM**

The ornamental design of the slatwall extrusion, as shown  
and described.

**DESCRIPTION**

FIG. 1 is a perspective view of the new slatwall extrusion  
design having two panels with a hanger lip at each of their  
lower ends, and with its connecting ends shown in broken  
lines;

FIG. 2 is a front view of the slatwall extrusion;

FIG. 3 is a rear view of the slatwall extrusion;

FIG. 4 is a top end view of the slatwall extrusion;

FIG. 5 is a bottom end view of the slatwall extrusion;

FIG. 6 is a side view of the slatwall extrusion showing it  
mounted to a wall and supporting a hanger bracket, which  
are both shown in broken lines;

FIG. 7 is a perspective view of a second embodiment of the  
new slatwall extrusion design having two panels with an  
offset hanger lip and cross web at each of their lower ends,  
and with its cross web and connecting ends shown in broken  
lines;

FIG. 8 is a side view of the second embodiment of the  
slatwall extrusion;

FIG. 9 is a perspective view of a third embodiment of the  
new slatwall extrusion design having two panels with a  
hanger lip and offset cross web at each of their lower ends,  
and with the cross web and its connecting ends shown in  
broken lines;

FIG. 10 is a side view of the third embodiment of the  
slatwall extrusion;

FIG. 11 is a perspective view of a fourth embodiment of the  
new slatwall extrusion design having three panel with a  
hanger lip at its lower end, and with its connecting ends  
shown in broken lines;

FIG. 12 is a perspective view of a fifth embodiment of the  
new slatwall extrusion design having three panels with an  
offset hanger lip and cross web at each of their lower ends,  
and with its cross web and connecting ends shown in broken  
lines;

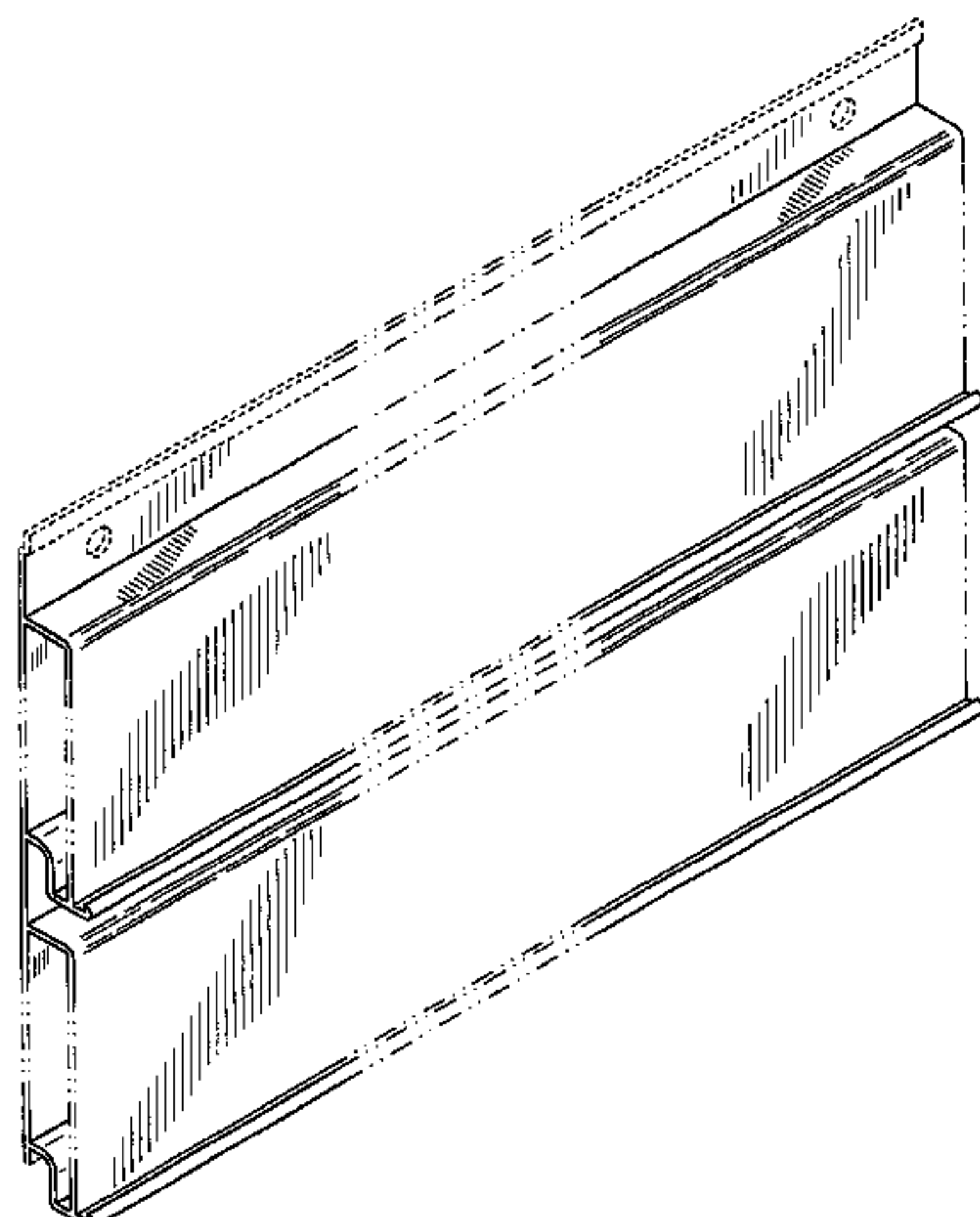

FIG. 13 is a perspective view of a sixth embodiment of the new slatwall extrusion design having three panels with a hanger lip and offset cross web at each of their lower ends, and with the cross web and its connecting ends shown in broken lines;

FIG. 14 is a side view of the fourth embodiment of the slatwall extrusion;

FIG. 15 is a side view of the fifth embodiment of the slatwall extrusion;

FIG. 16 is a side view of the sixth embodiment of the slatwall extrusion;

FIG. 17 is a perspective view of a seventh embodiment of the new slatwall extrusion design having four panel with a hanger lip at its lower end, and with its connecting ends shown in broken lines;

FIG. 18 is a perspective view of a eight embodiment of the new slatwall extrusion design having four panels with an offset hanger lip and cross web at each of their lower ends, and with the cross web and its connecting ends shown in broken lines;

FIG. 19 is a perspective view of a ninth embodiment of the new slatwall extrusion design having four panels with a hanger lip and offset cross web at each of their lower ends, and with the cross web and its connecting ends shown in broken lines;

FIG. 20 is a side view of the seventh embodiment of the slatwall extrusion;

FIG. 21 is a side view of the eighth embodiment of the slatwall extrusion; and,

FIG. 22 is a side view of the ninth embodiment of the slatwall extrusion.

The side views opposite those in FIGS. 6, 8, 10, 14–16 and 20–22 are mirror images. The broken lines showing the connecting ends, fastener holes, cross web, wall and hanger are for illustrative purposes only and form no part of the claimed design. The remaining broken lines in the drawings are to disclose the indeterminate length of the slatwall extrusion and the indeterminate width of its panels.

**1 Claim, 15 Drawing Sheets**

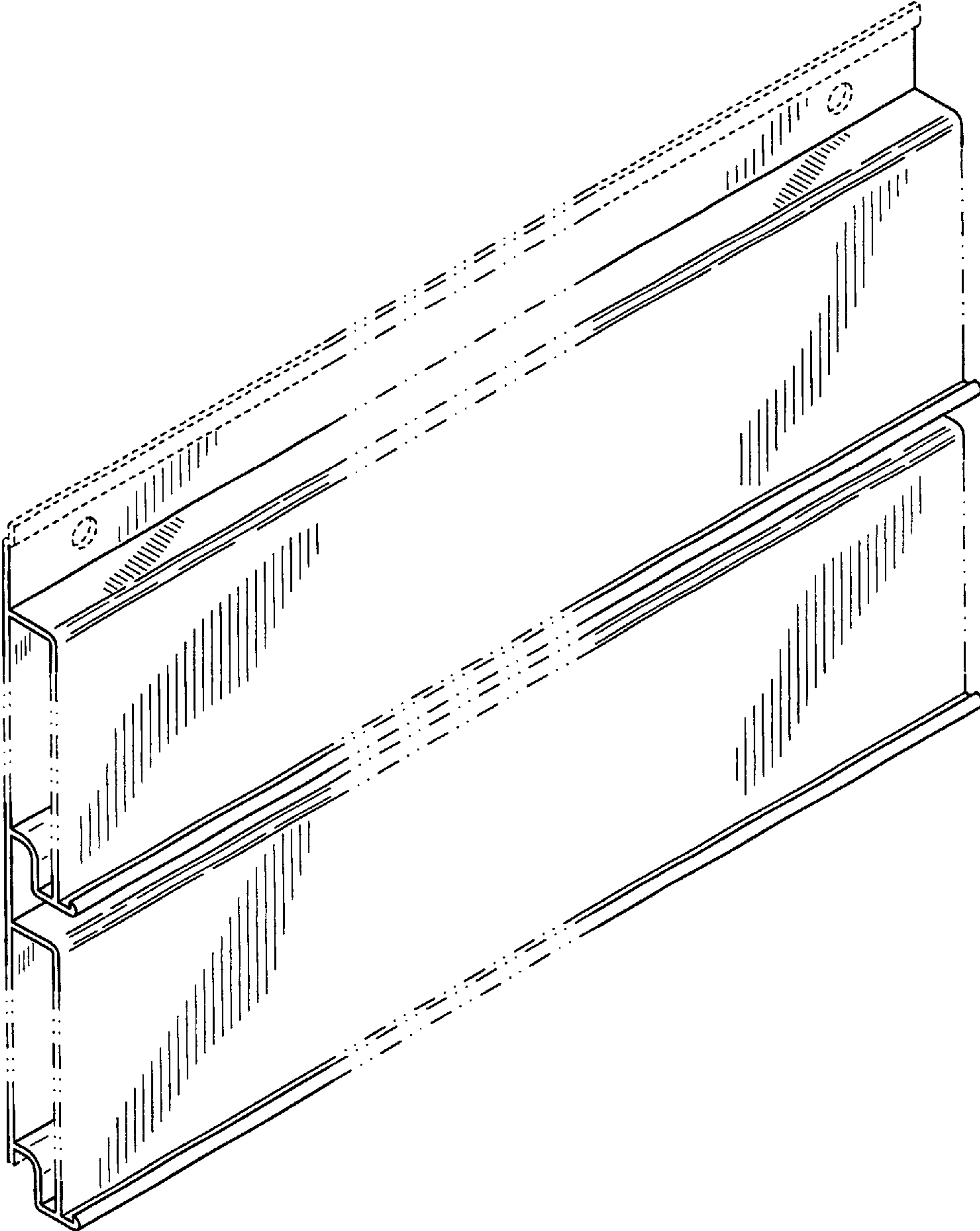

FIG. 1

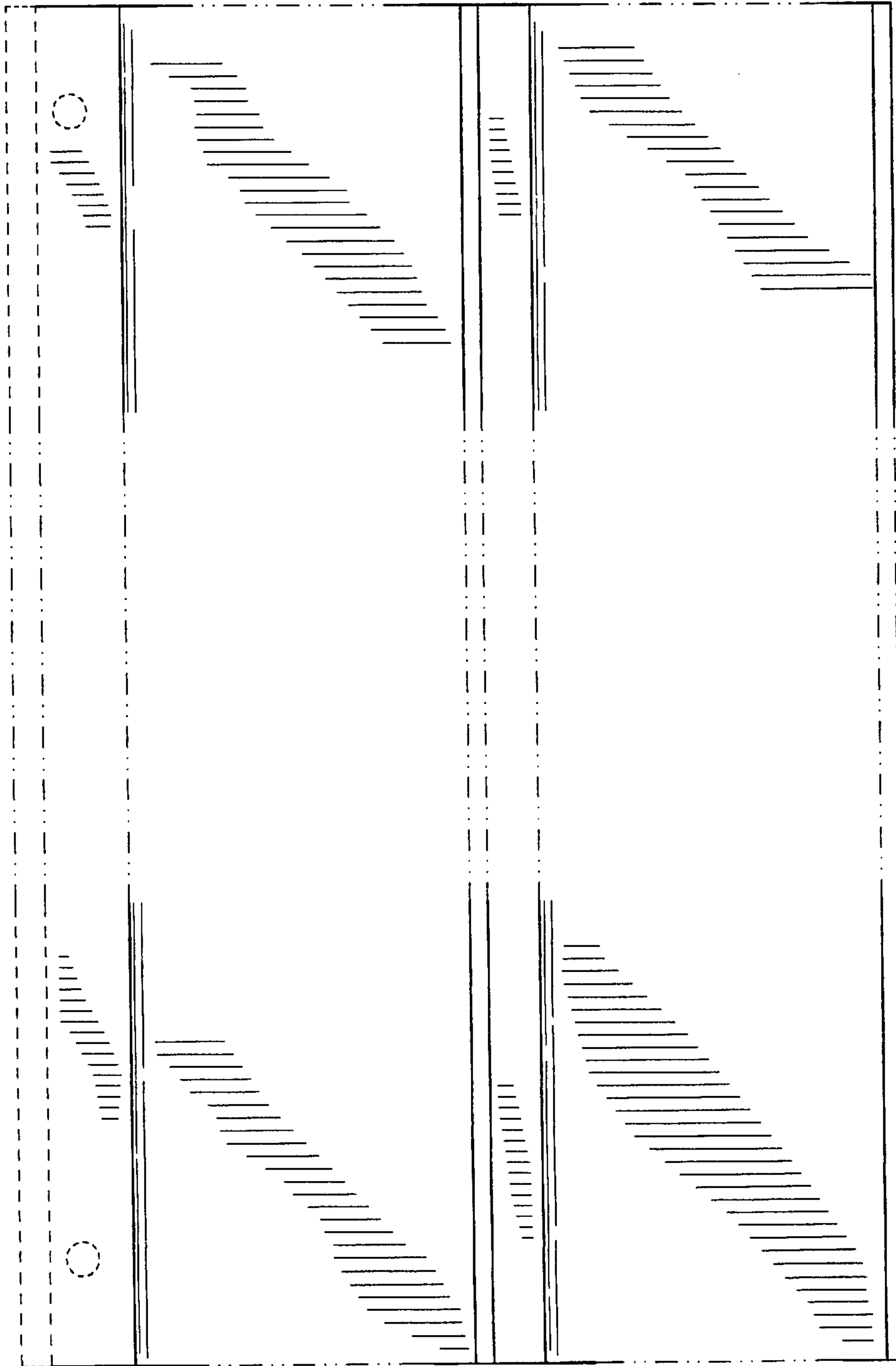

FIG. 2

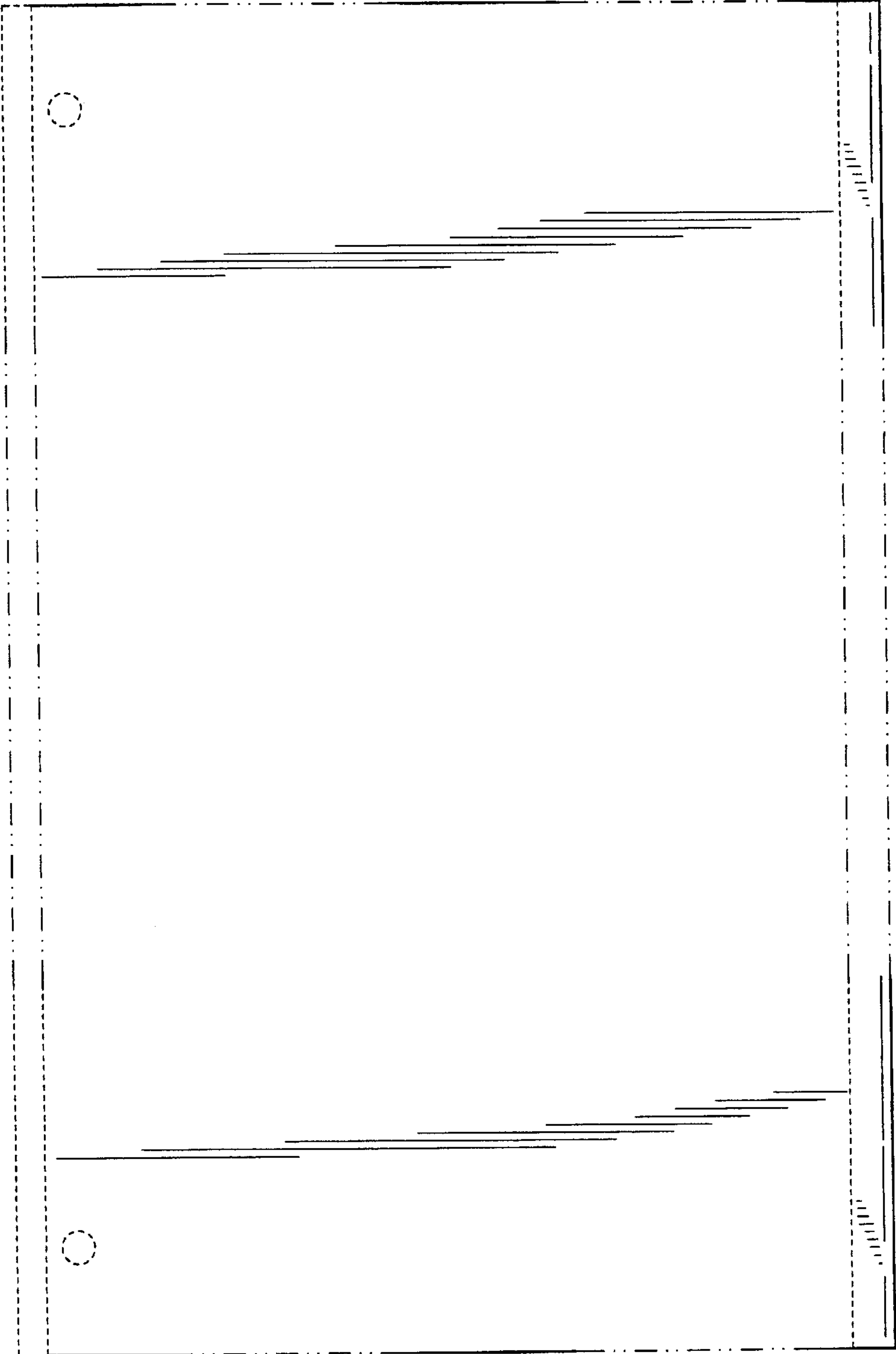

FIG. 3



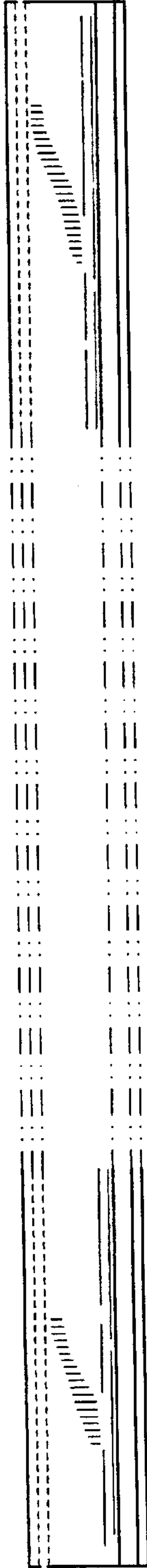

FIG. 4



FIG. 5

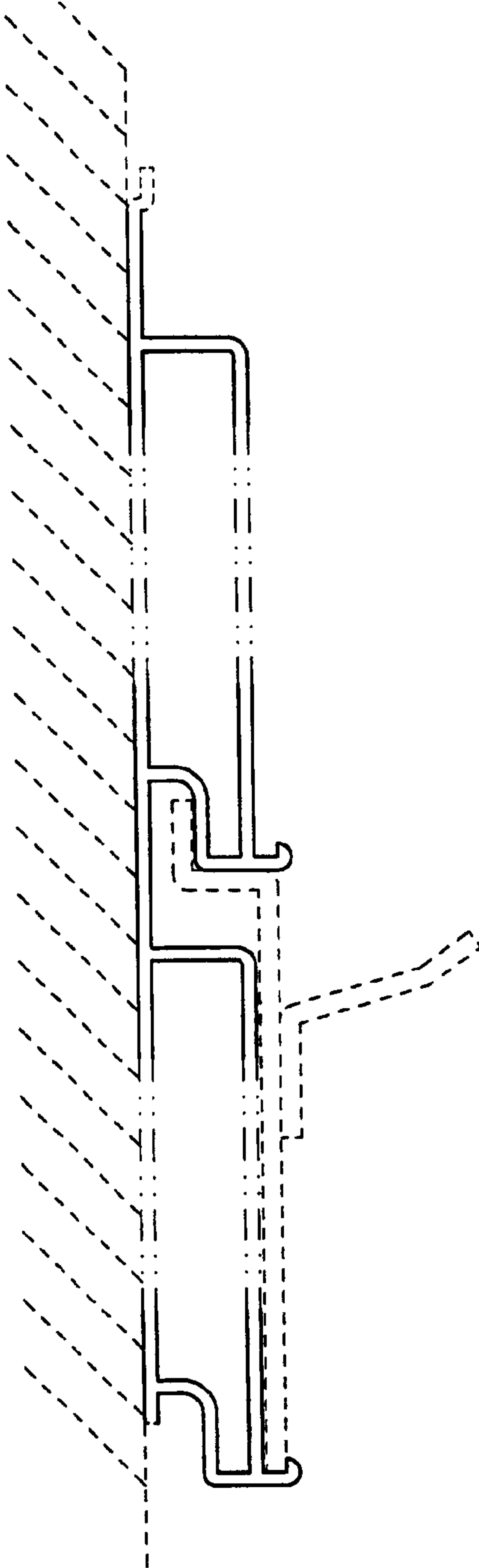

FIG. 6

FIG. 7

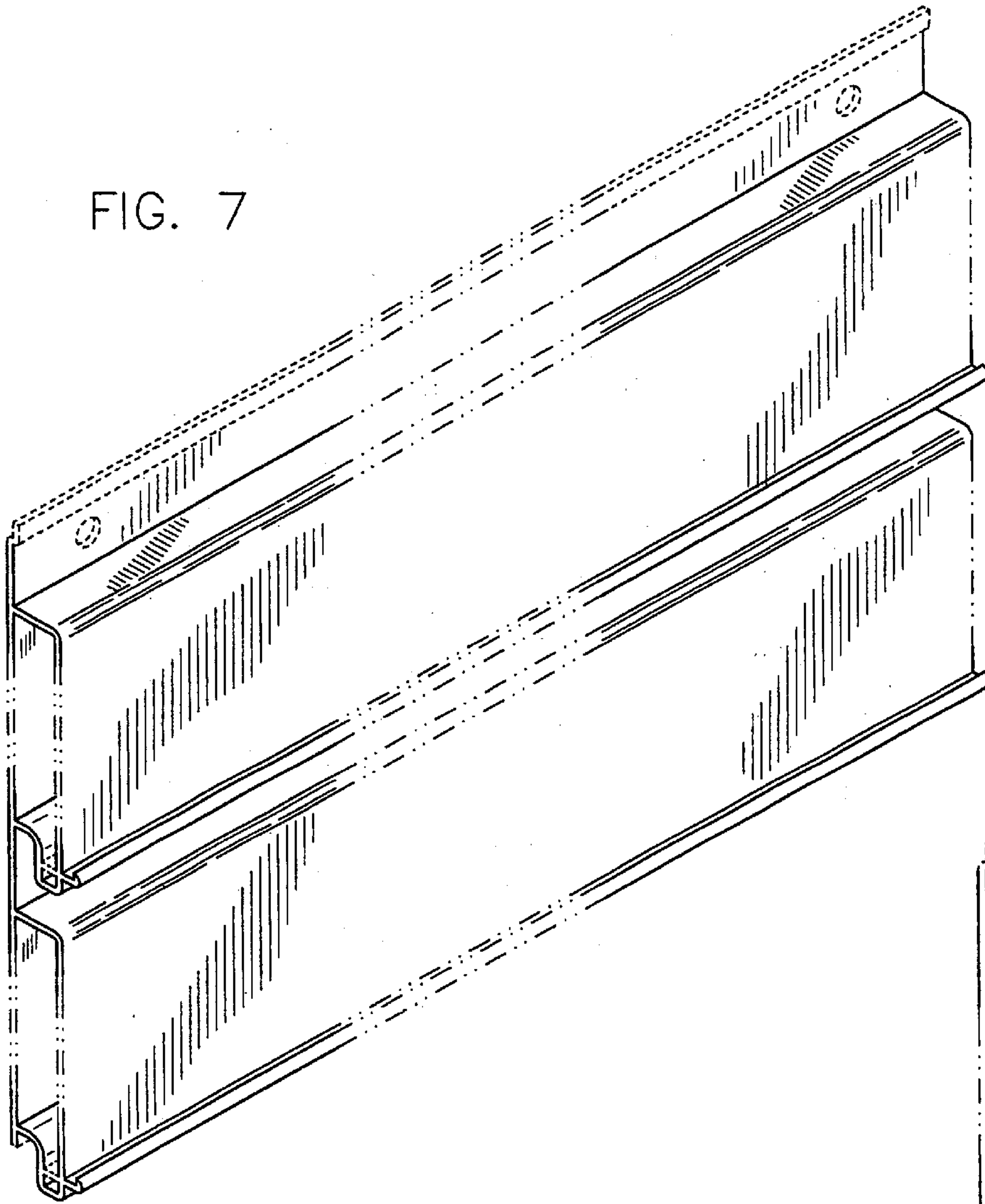

FIG. 8

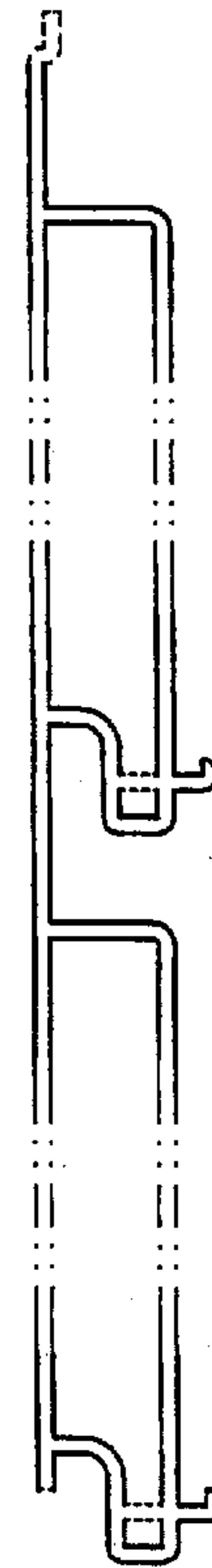



FIG. 9

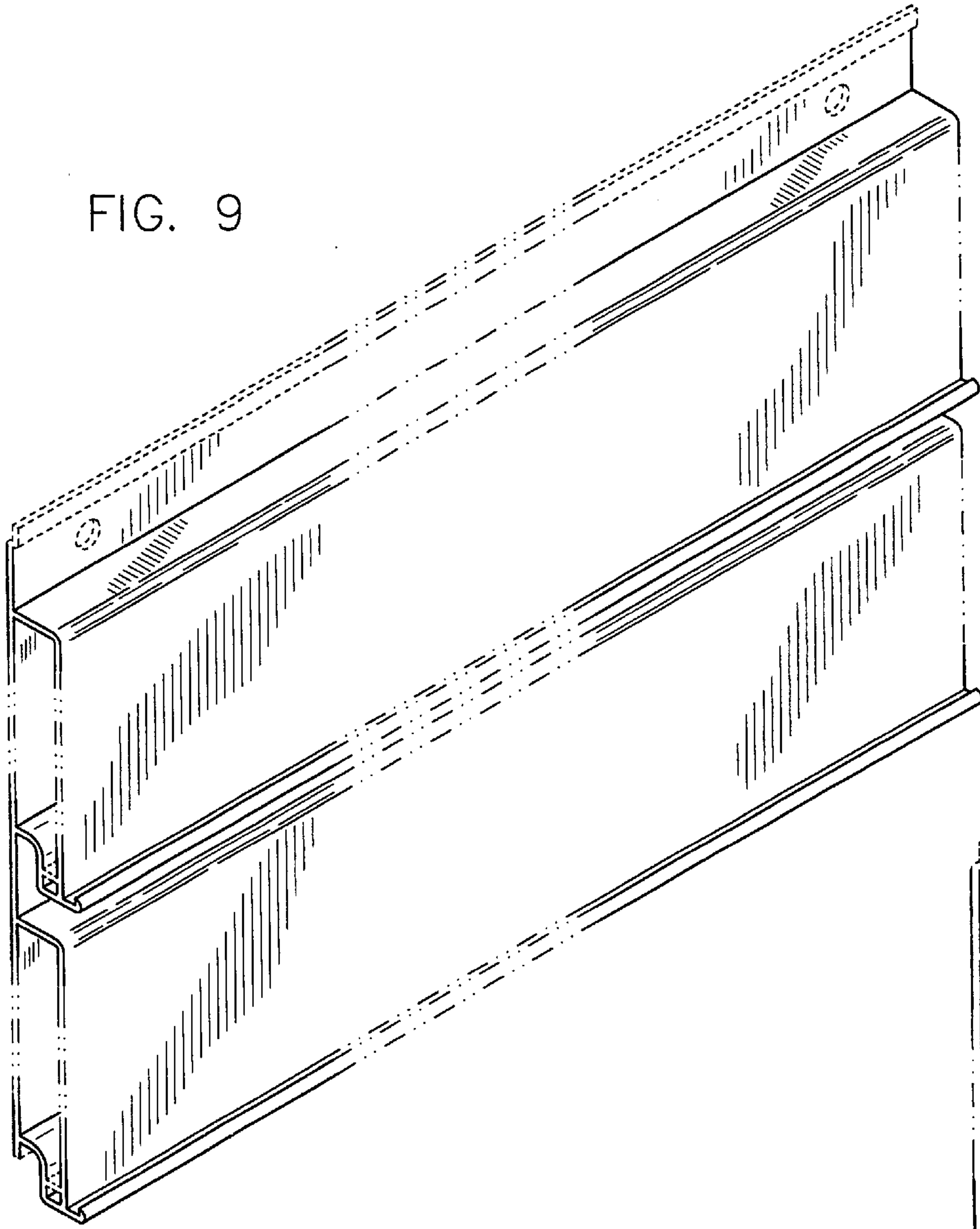
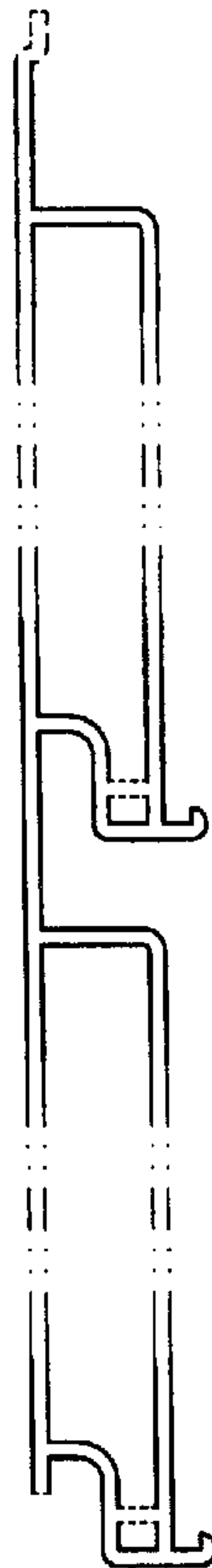

FIG. 10



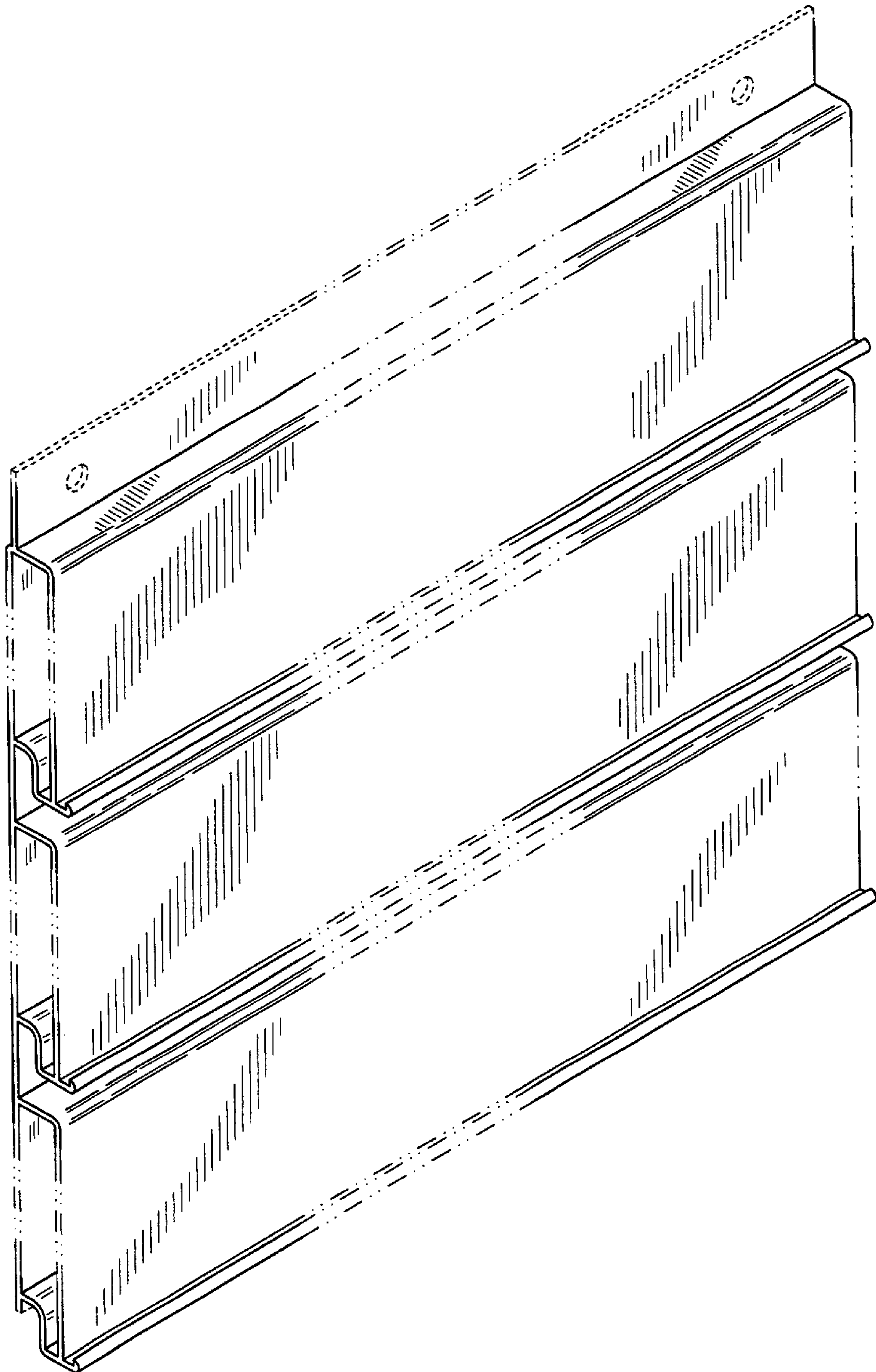

FIG. 11

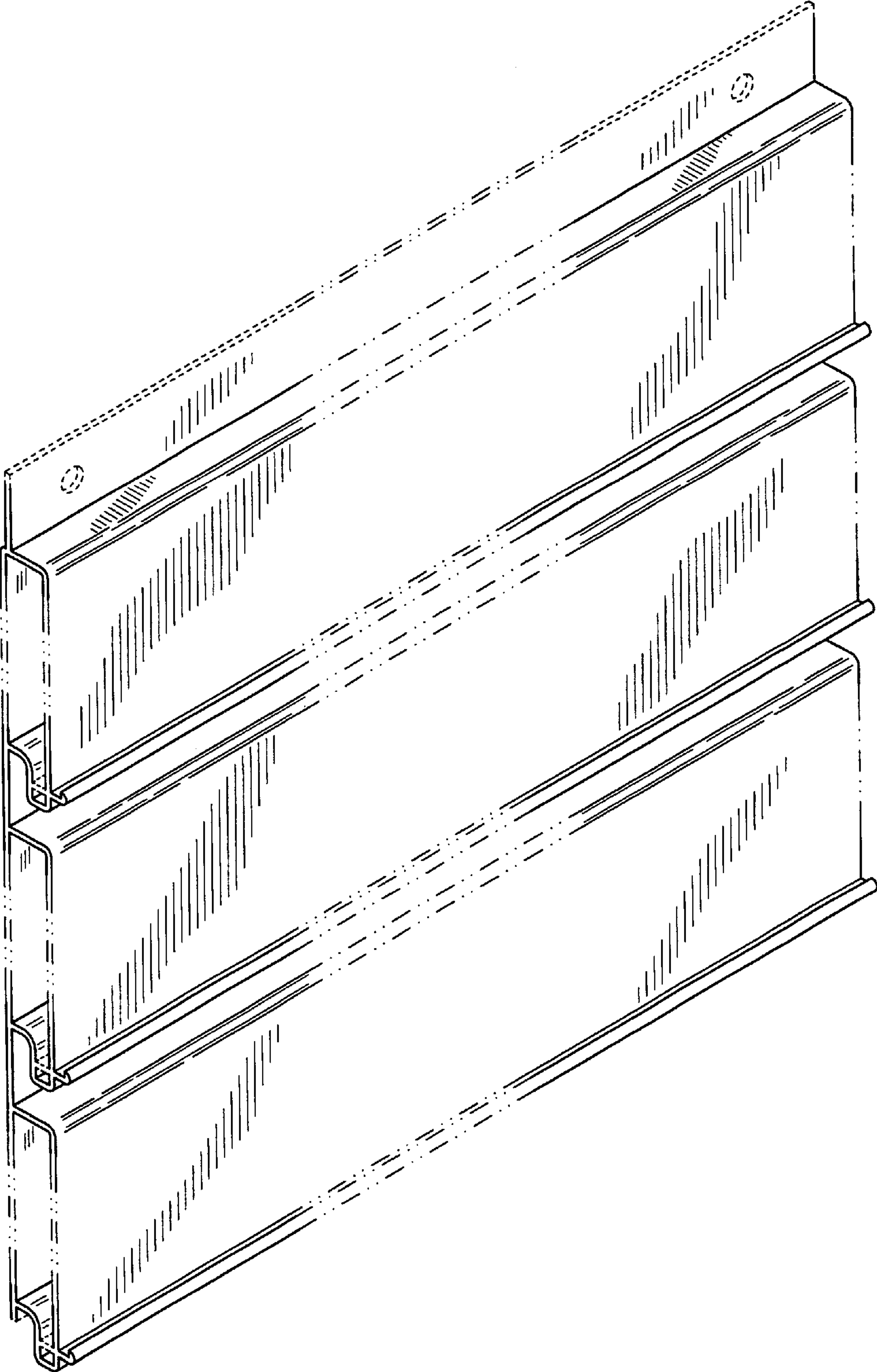

FIG. 12

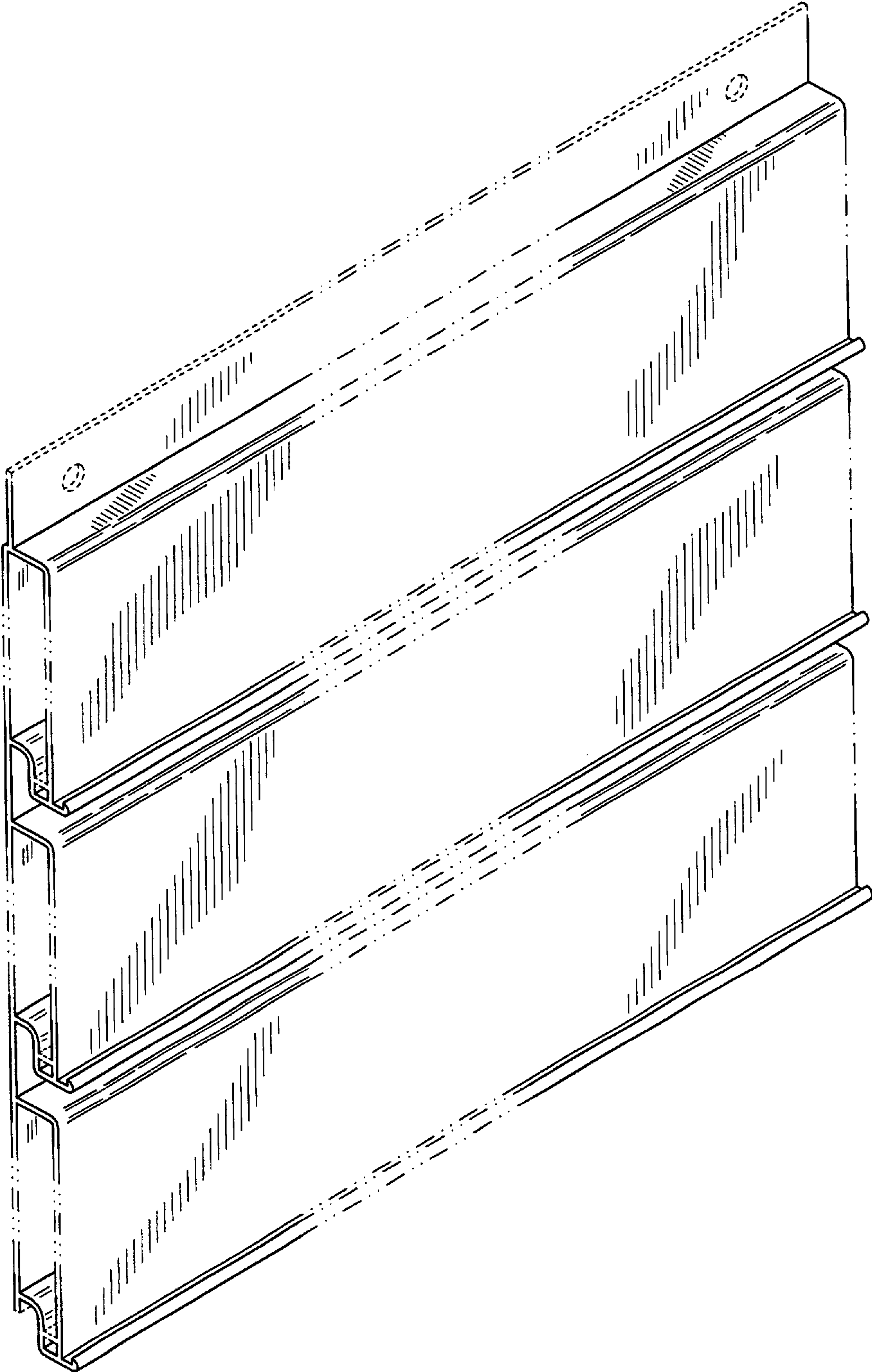

FIG. 13

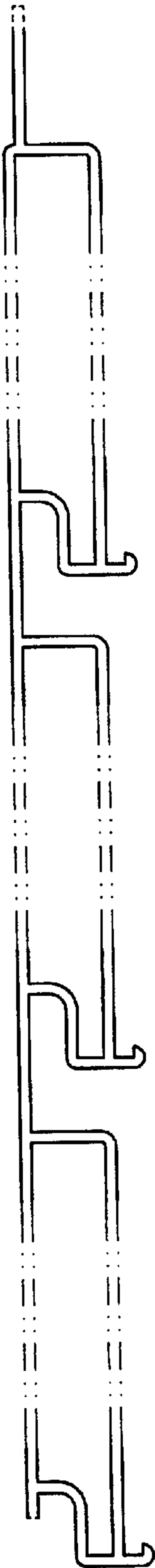

FIG. 14

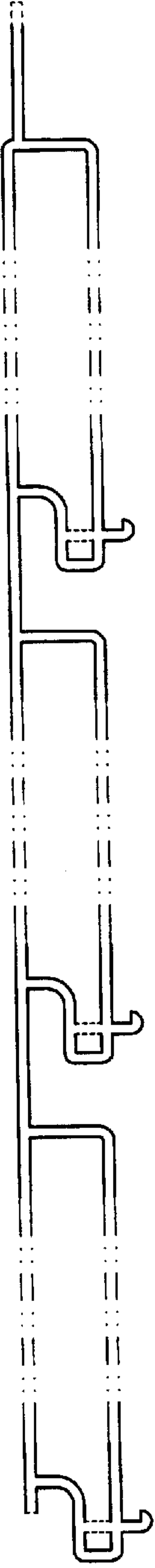

FIG. 15

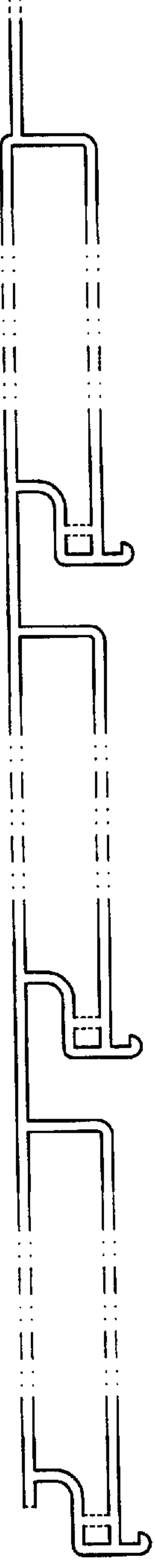

FIG. 16



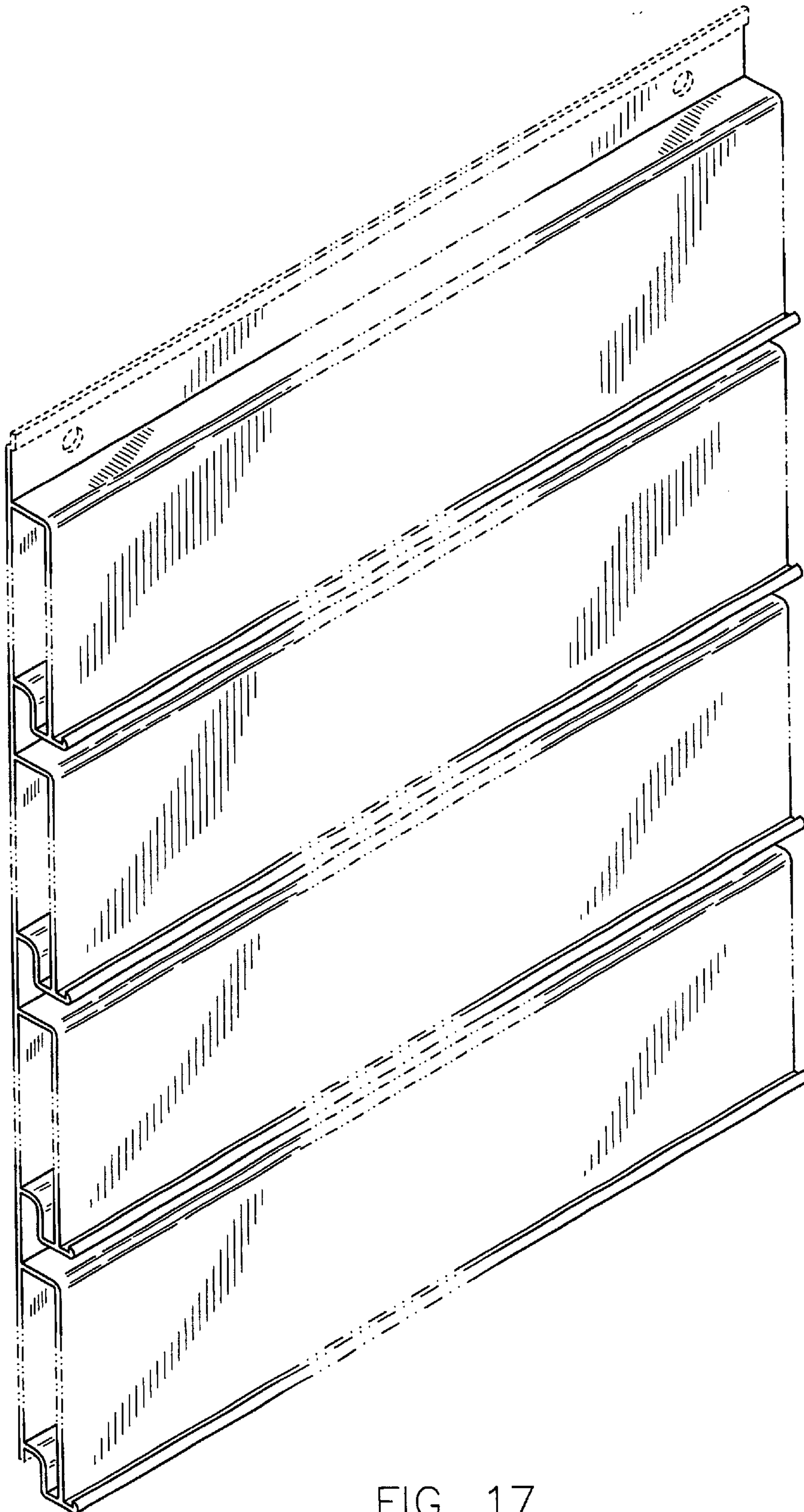

FIG. 17



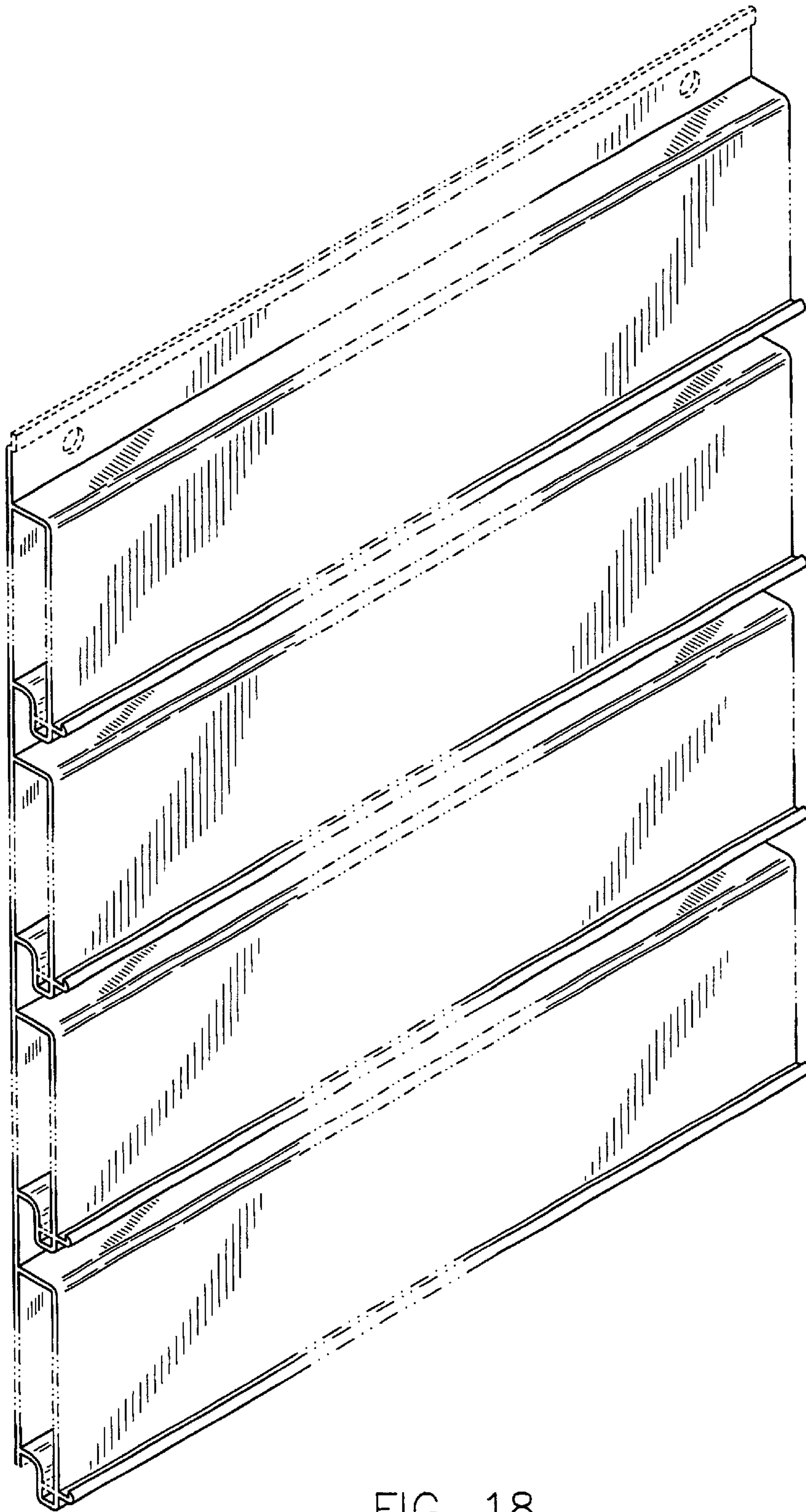

FIG. 18

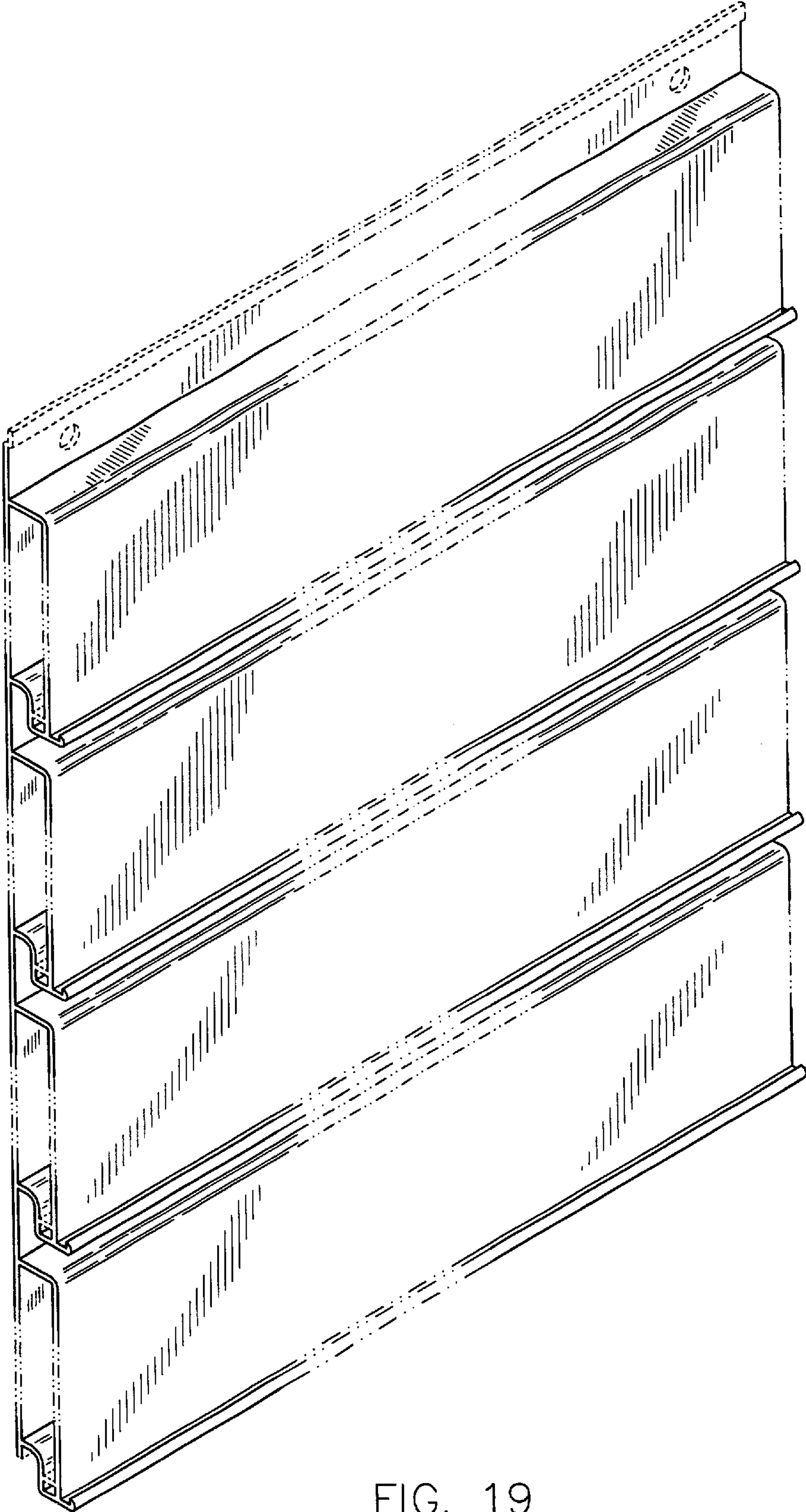

FIG. 19

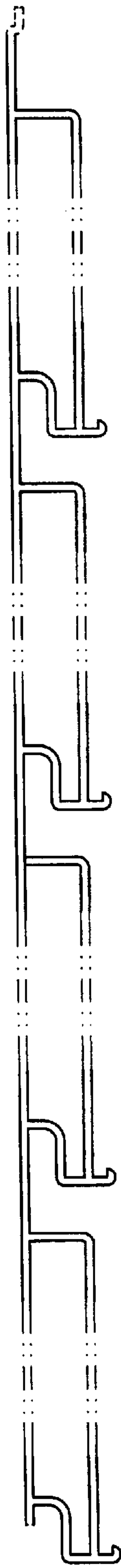

FIG. 20

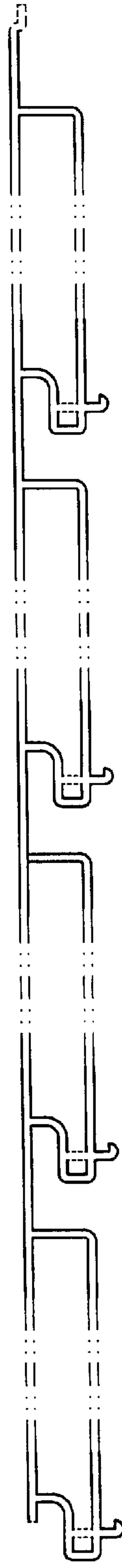

FIG. 21

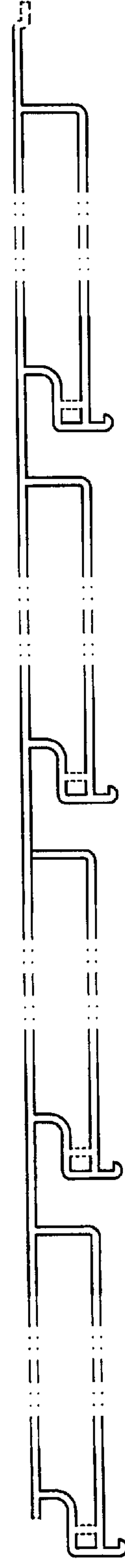

FIG. 22