

US00D507208S

(12) **United States Design Patent**
Ulch

(10) **Patent No.:** **US D507,208 S**
(45) **Date of Patent:** **** Jul. 12, 2005**

(54) **MOTORCYCLE AERODYNAMIC STORAGE TRAILER**

(75) Inventor: **Christopher S. Ulch**, Edgewater, FL (US)

(73) Assignee: **Fab Metal Services, LLC.**, Edgewater, FL (US)

(**) Term: **14 Years**

(21) Appl. No.: **29/200,330**

(22) Filed: **Feb. 25, 2004**

(51) **LOC (8) Cl.** **12-10**

(52) **U.S. Cl.** **D12/102**

(58) **Field of Search** D12/102, 101,
D12/103; 280/475, 656, 763.1, 482, 204;
296/181, 190

(56) **References Cited**

U.S. PATENT DOCUMENTS

4,256,321 A	3/1981	Trulove	280/204
D288,419 S	* 2/1987	Read et al.	D12/102
D340,429 S	10/1993	Smith	D12/102
5,308,096 A	5/1994	Smith	280/204
5,641,173 A	6/1997	Cobb, Jr.	280/204
D384,010 S	9/1997	Chiu	D12/102
5,687,980 A	11/1997	Eckroth	280/202
D391,526 S	* 3/1998	Kass et al.	D12/102
D394,619 S	* 5/1998	DeShong et al.	D12/102
5,785,333 A	7/1998	Hinkston	280/204
D400,476 S	11/1998	Winchester	D12/102
6,213,539 B1	4/2001	Williams	296/181
6,409,194 B1	6/2002	Voas	280/204
D495,276 S	* 8/2004	Armstrong	D12/102

* cited by examiner

Primary Examiner—Melody N. Brown

(74) *Attorney, Agent, or Firm*—Brian S. Steinberger; Law Offices of Brian S. Steinberger, P.A.

(57) **CLAIM**

The ornamental design for a motorcycle aerodynamic storage trailer, as shown and described.

DESCRIPTION

FIG. 1 is an upper front right perspective view of a first embodiment design of the novel motorcycle aerodynamic storage trailer, and the broken lines are intended to represent a tow hitch, wheel and bumper which are not intended to be part of the invention

FIG. 2 is an upper rear left perspective view of the first embodiment design of FIG. 1.

FIG. 3 is a right side view of the first embodiment design of FIG. 1.

FIG. 4 is a left side view of the first embodiment design of FIG. 1.

FIG. 5 is a rear view of the first embodiment design of FIG. 1.

FIG. 6 is a front view of the first embodiment design of FIG. 1.

FIG. 7 is a top view of the first embodiment design of FIG. 1.

FIG. 8 is a bottom view of the first embodiment design of FIG. 1.

FIG. 9 is an upper front right perspective view of a second embodiment design of the novel motorcycle aerodynamic storage trailer with rear bumper, and the broken lines are intended to represent a tow hitch, and wheel which are not intended to be part of the invention

FIG. 10 is an upper rear left perspective view of the second embodiment design of FIG. 9.

FIG. 11 is a right side view of the second embodiment design of FIG. 9.

FIG. 12 is a left side view of the second embodiment design of FIG. 9.

FIG. 13 is a rear view of the second embodiment design of FIG. 9.

FIG. 14 is a front view of the second embodiment design of FIG. 9.

FIG. 15 is a top view of the second embodiment design of FIG. 9; and,

FIG. 16 is a bottom view of the second embodiment design of FIG. 9.

1 Claim, 10 Drawing Sheets

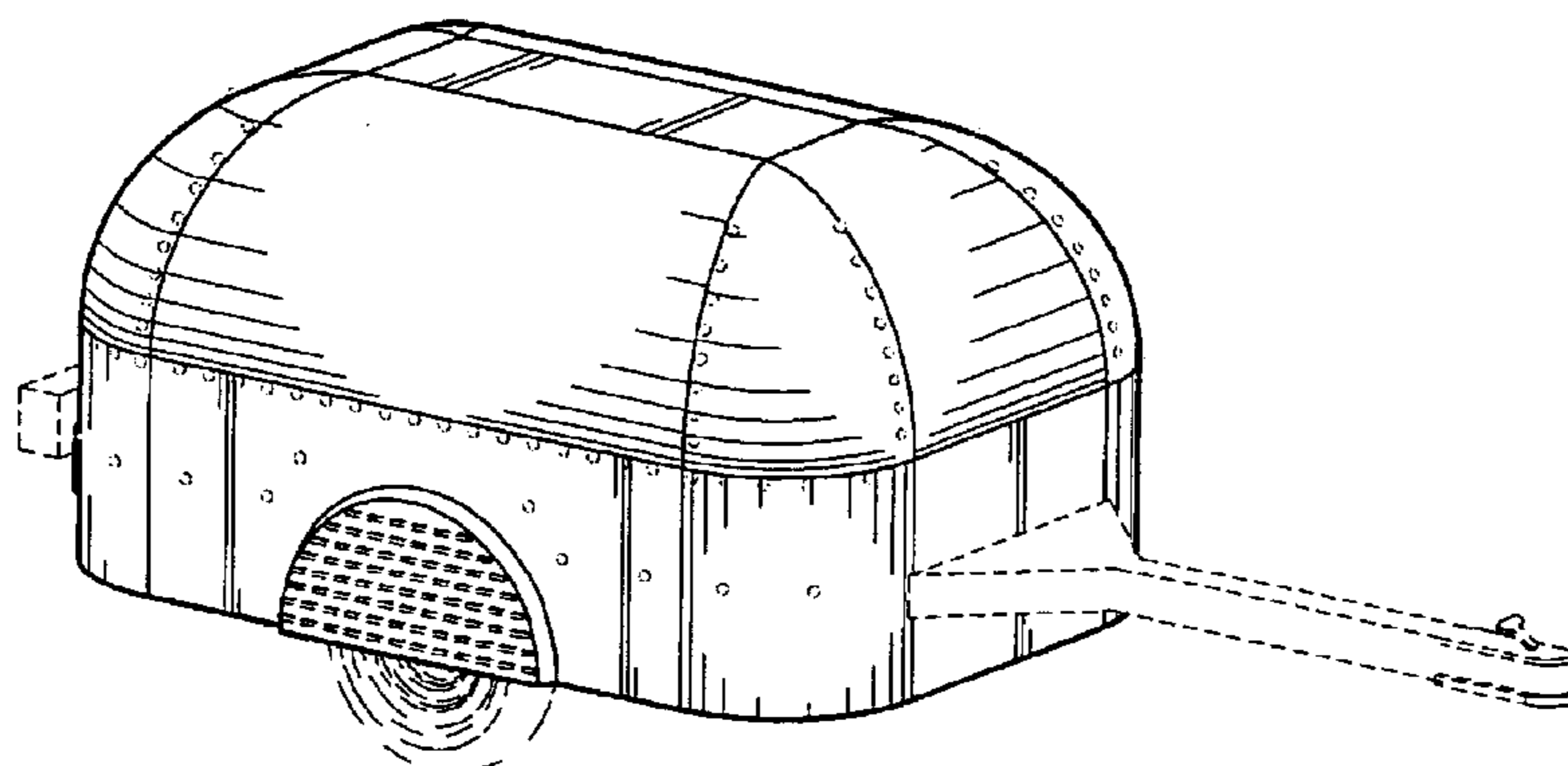

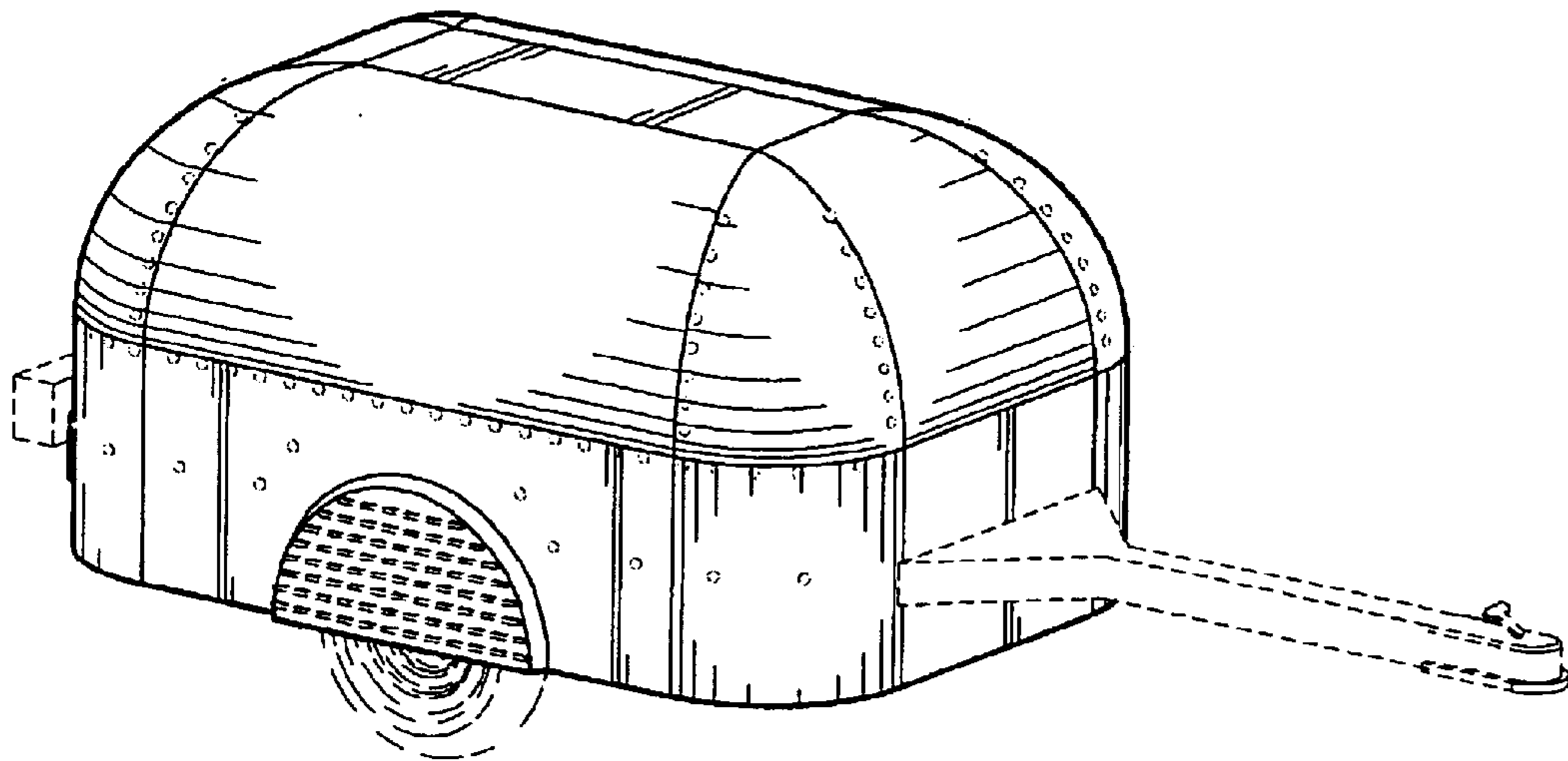

FIG - 1

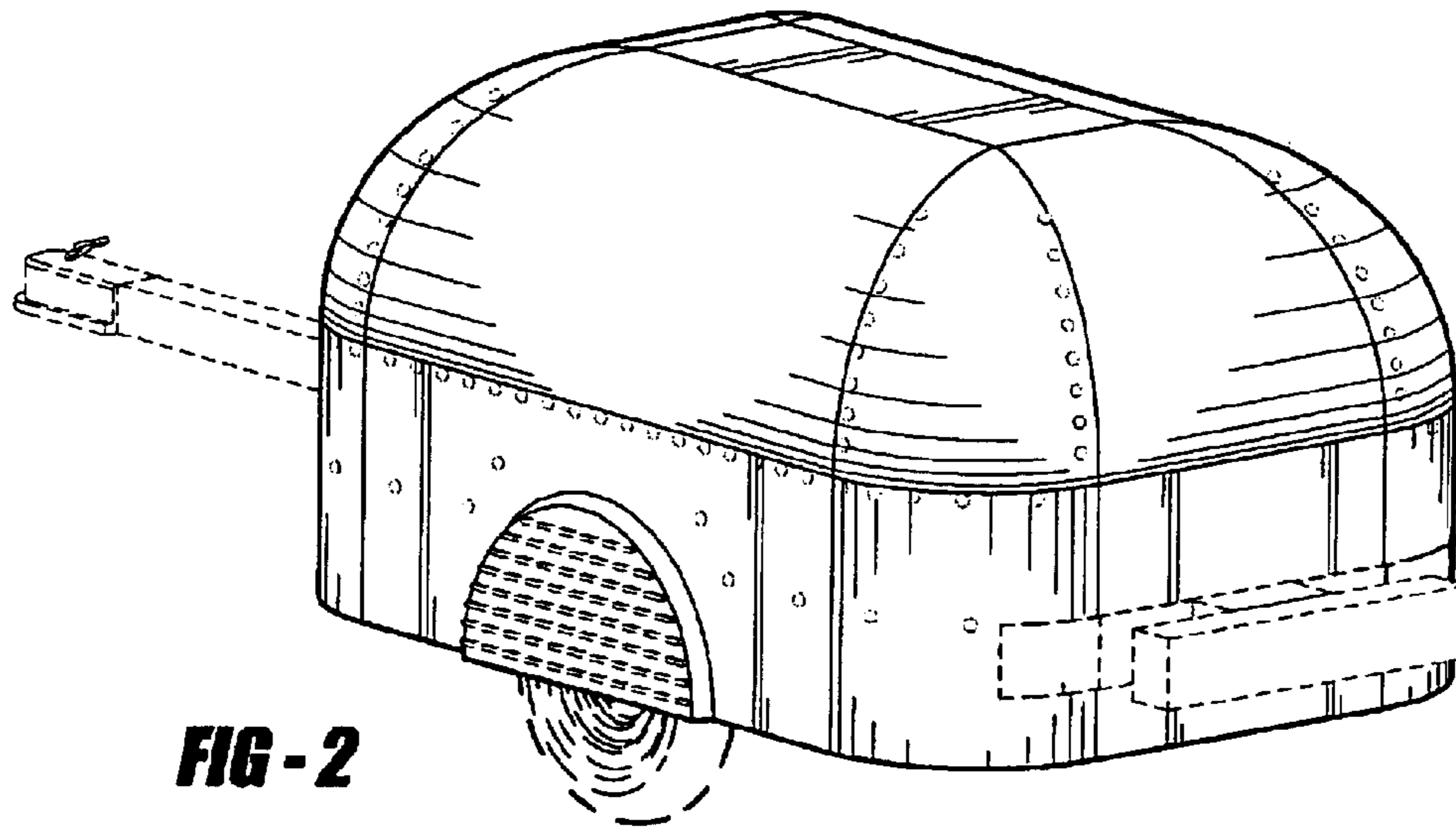
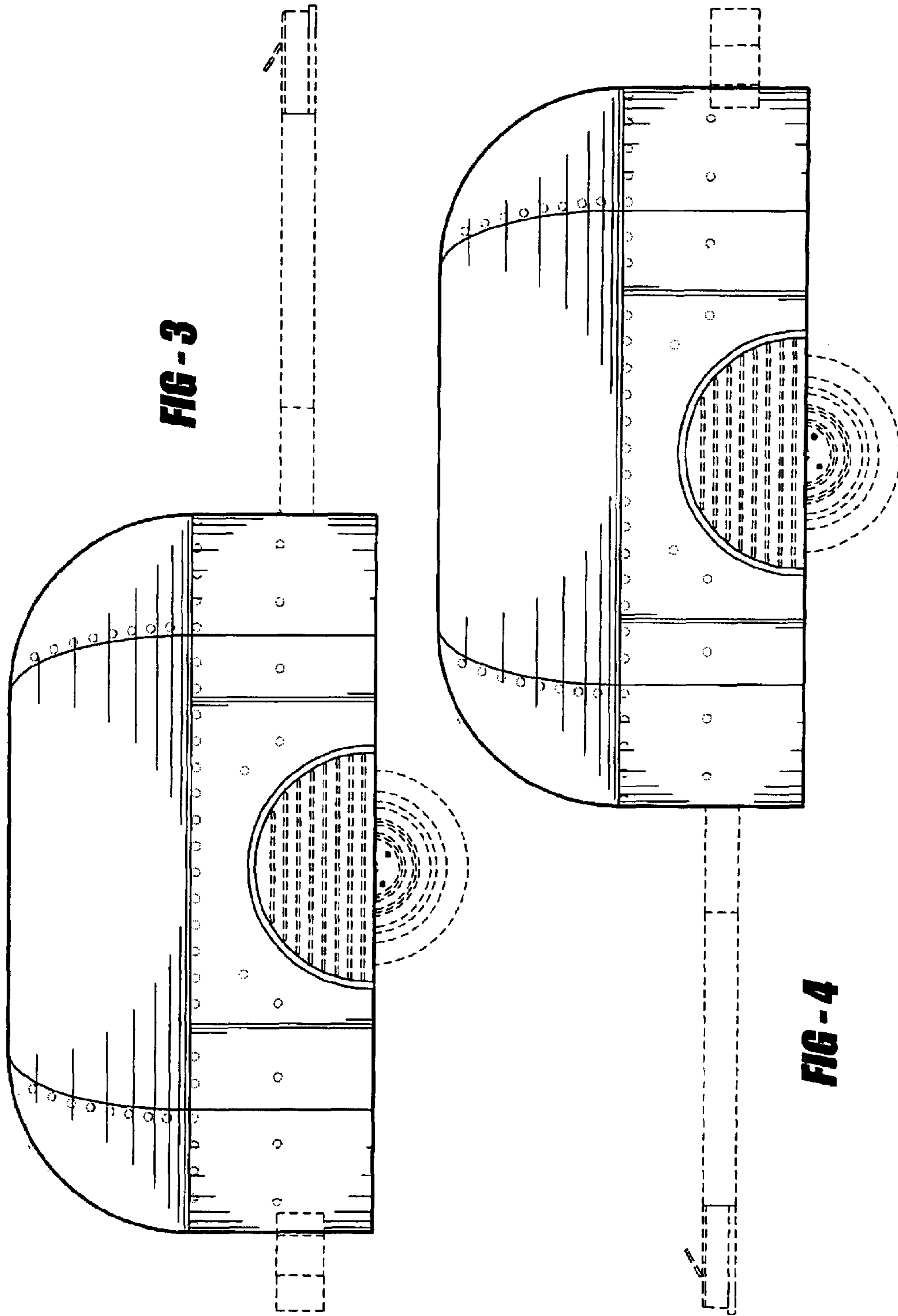
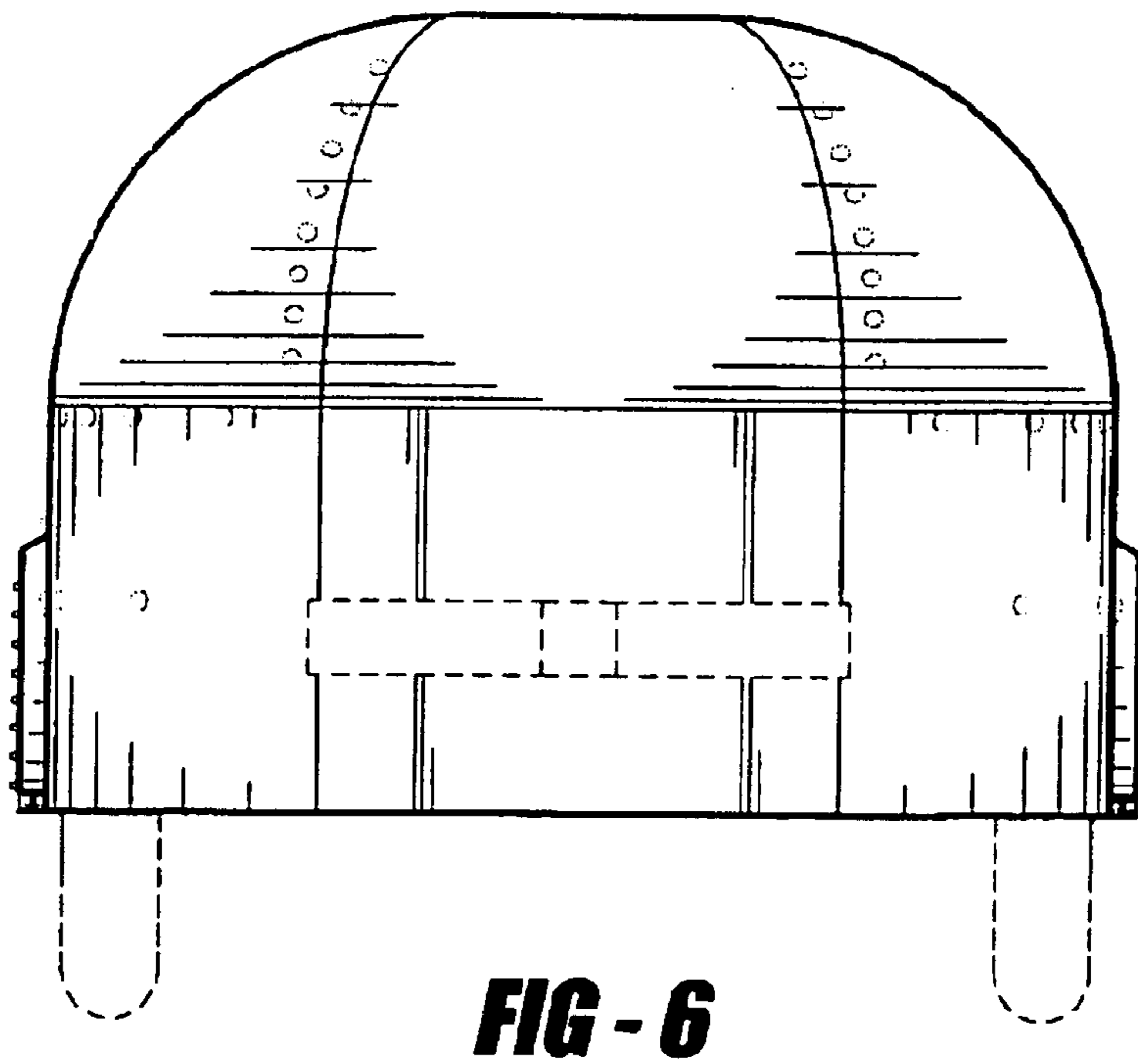
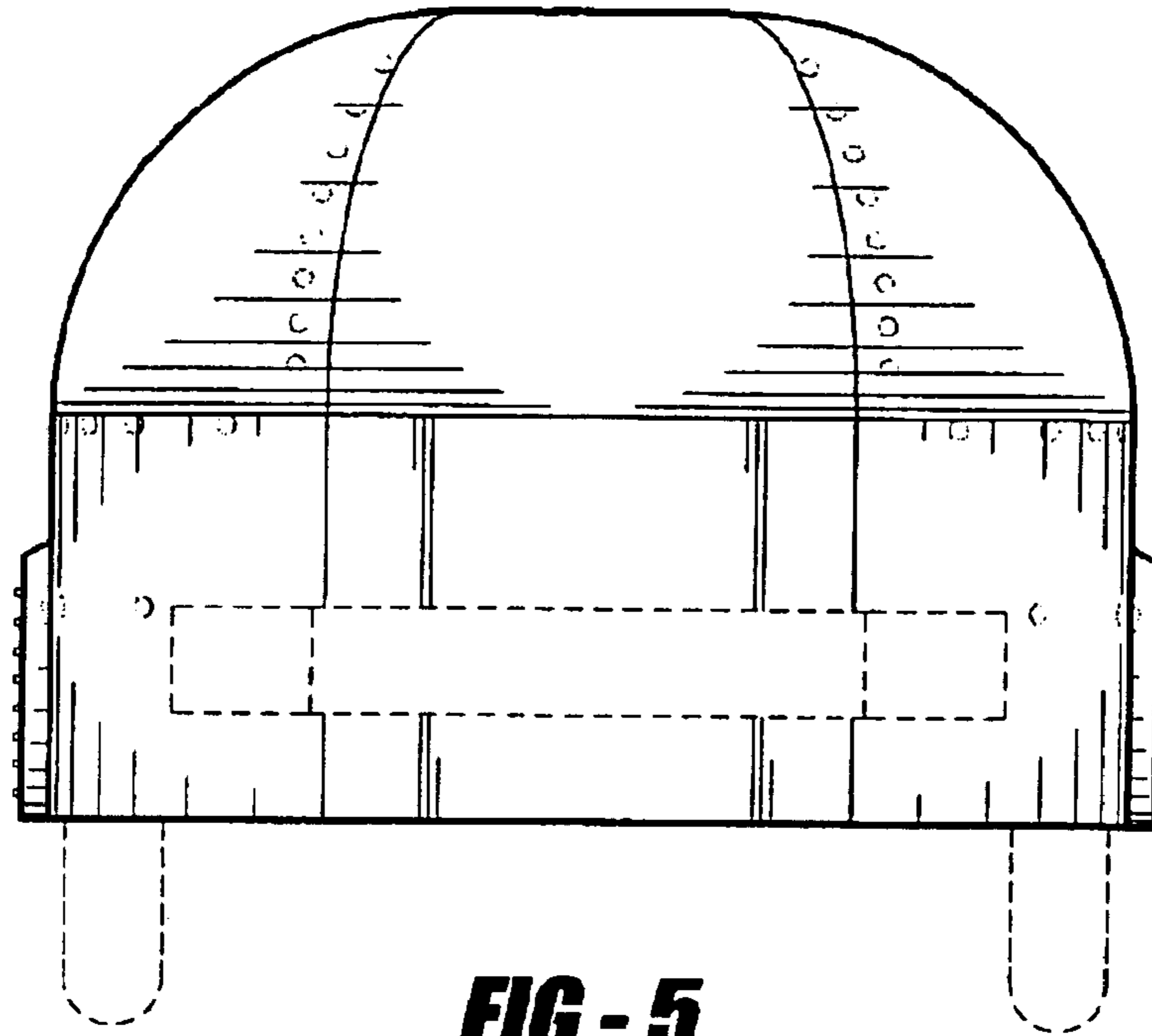

FIG - 2





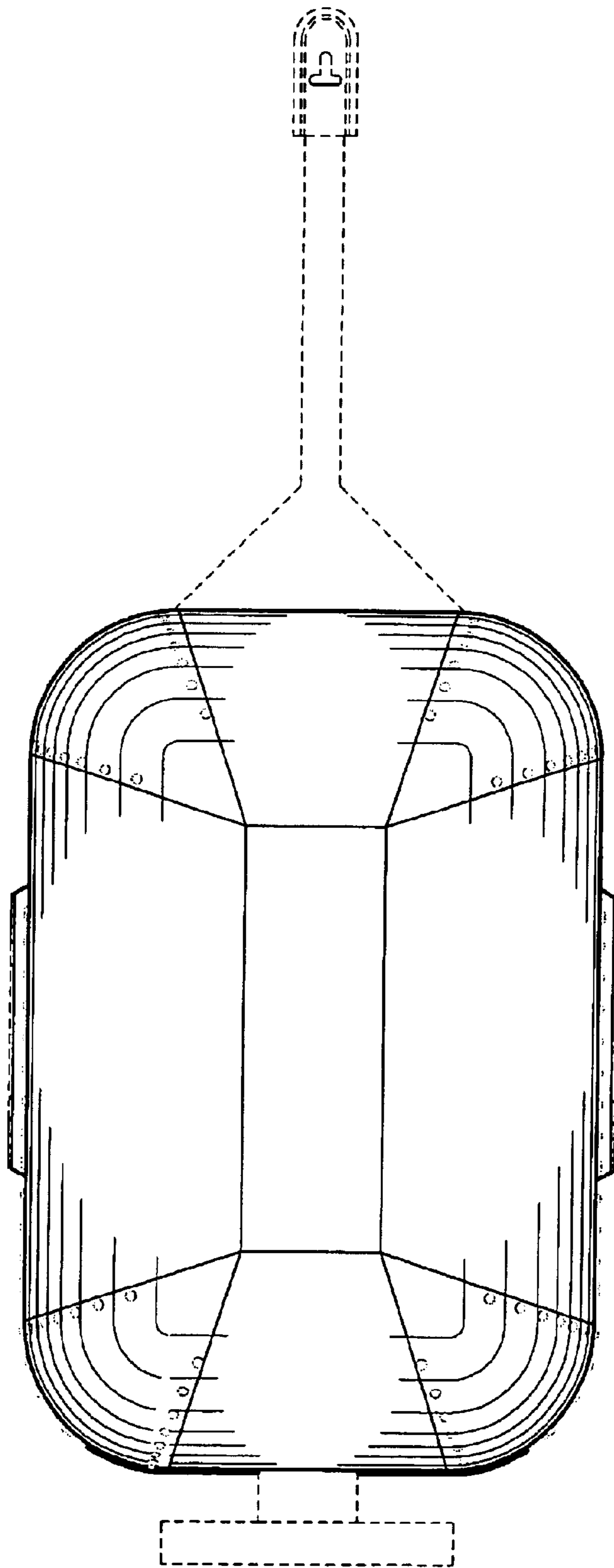

FIG - 7

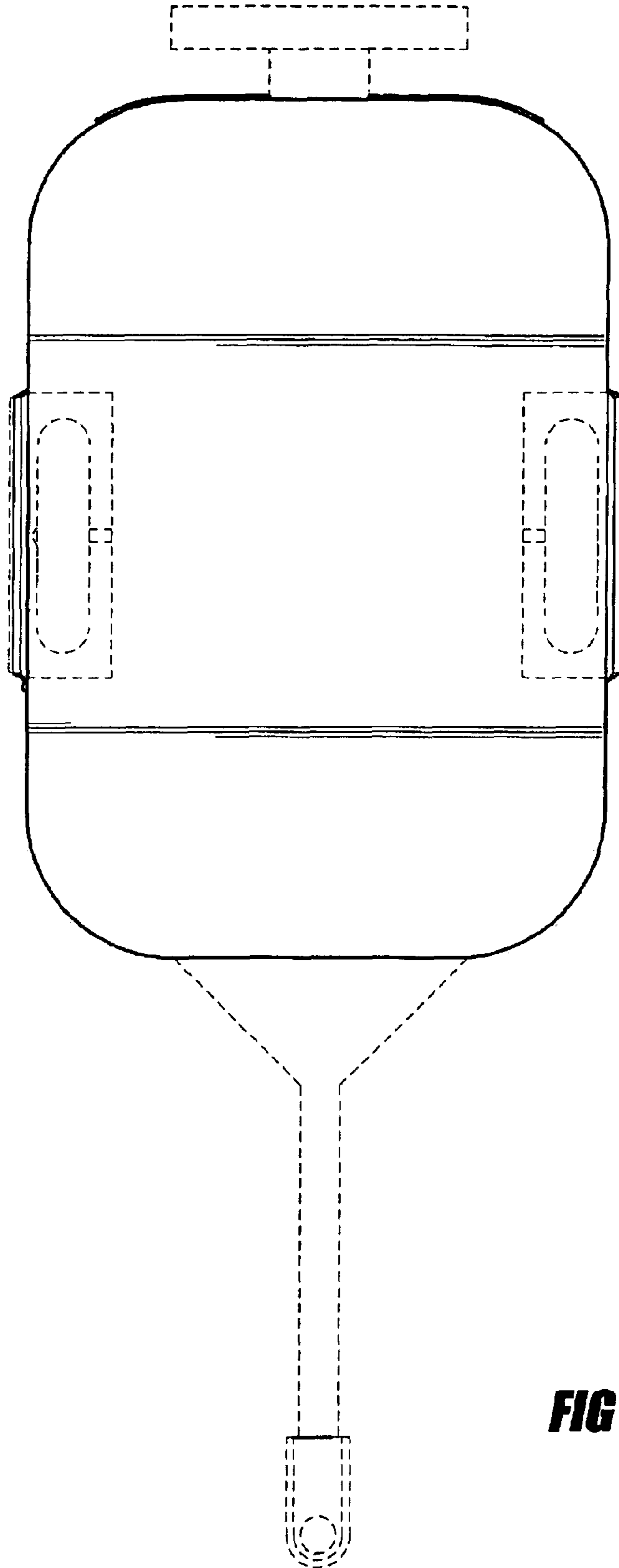

FIG - 8

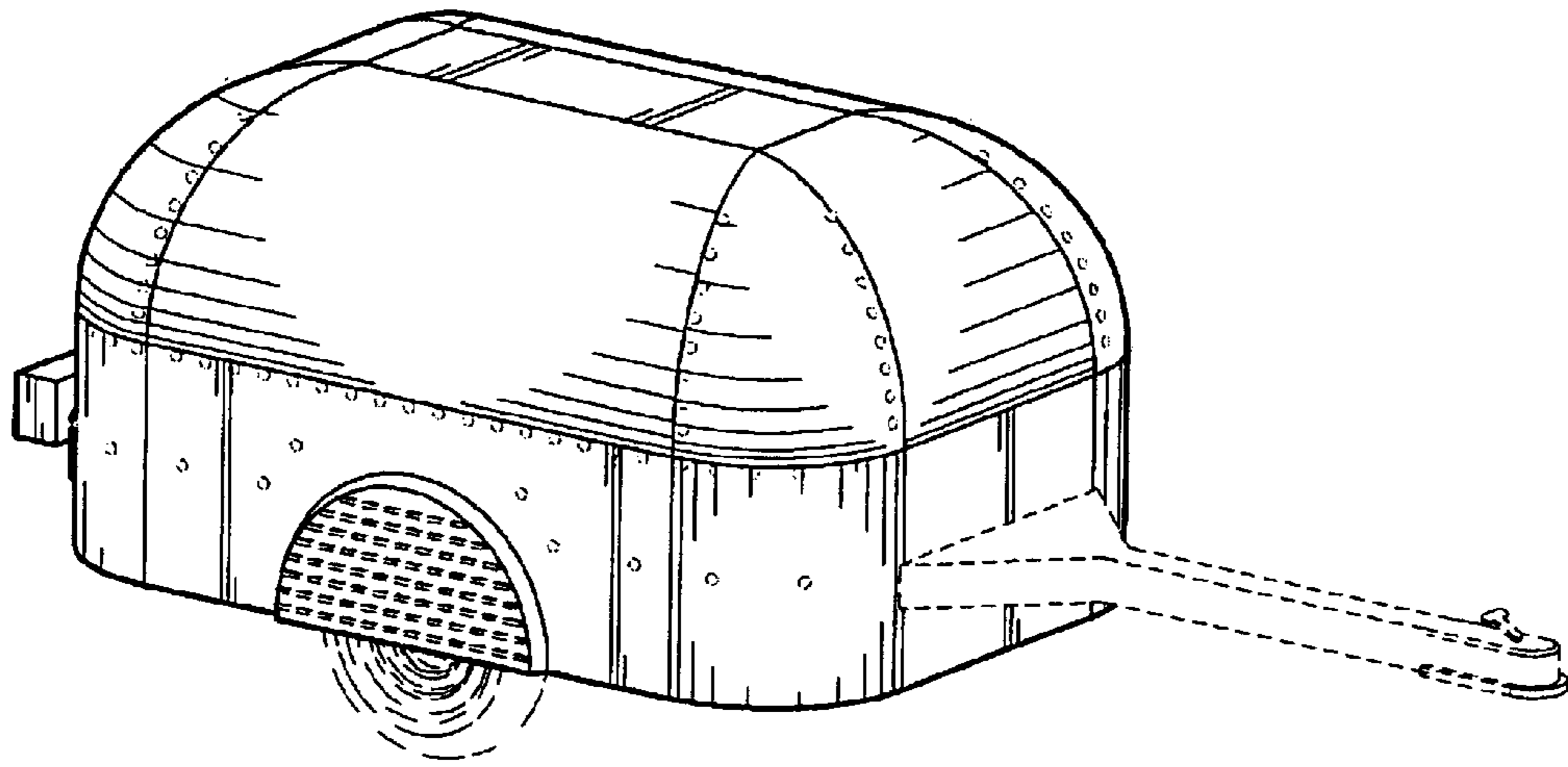

FIG - 9

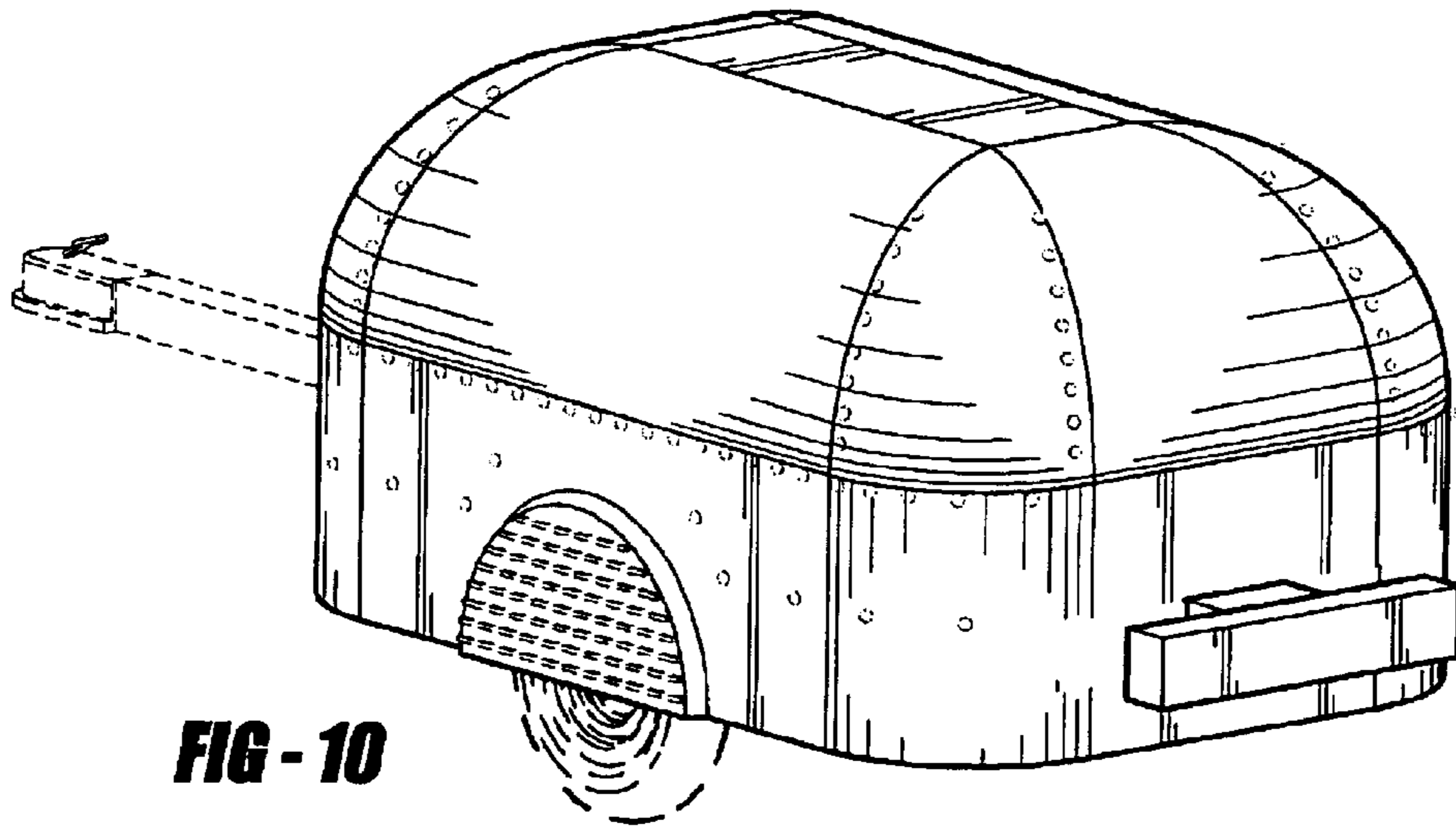
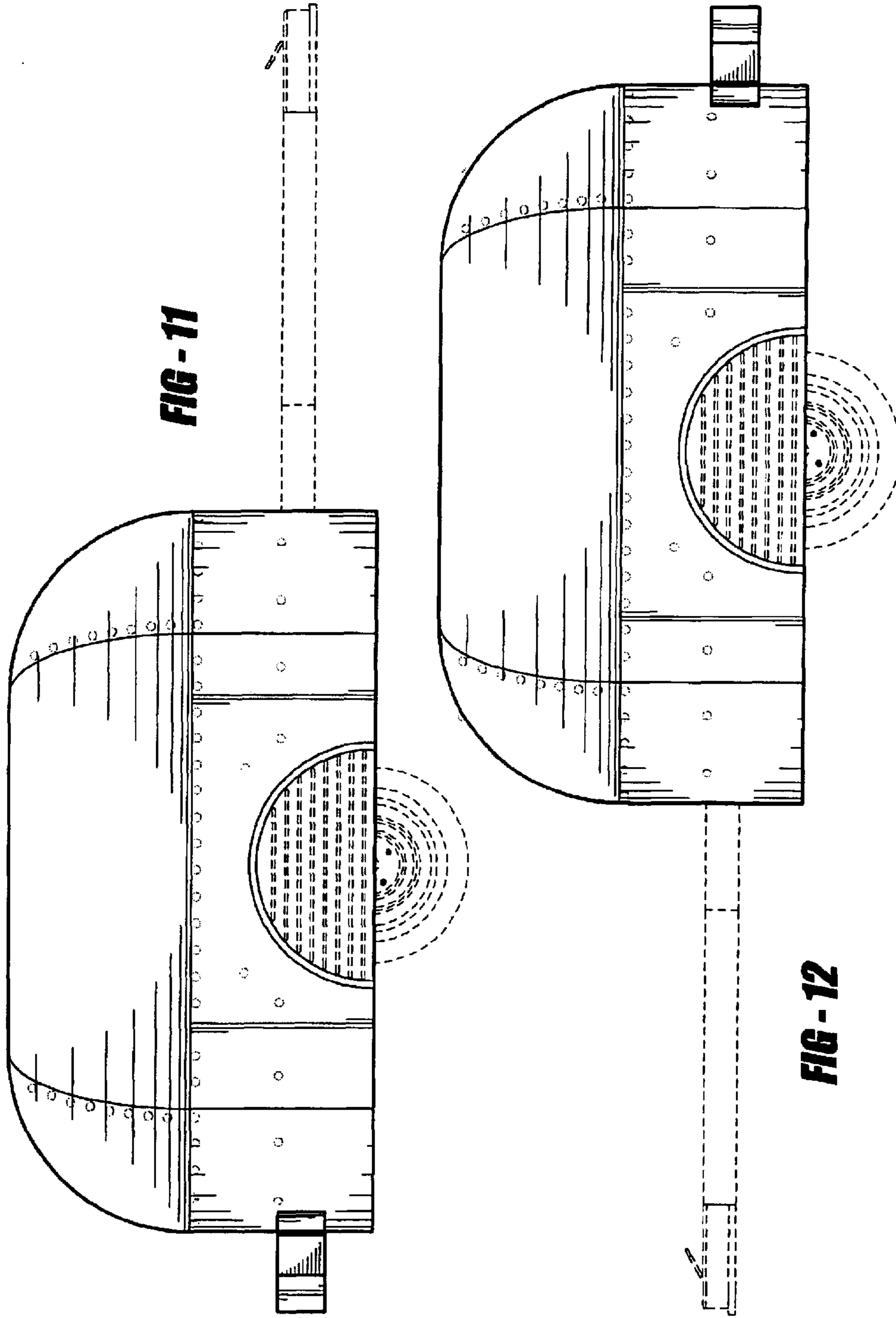

FIG - 10



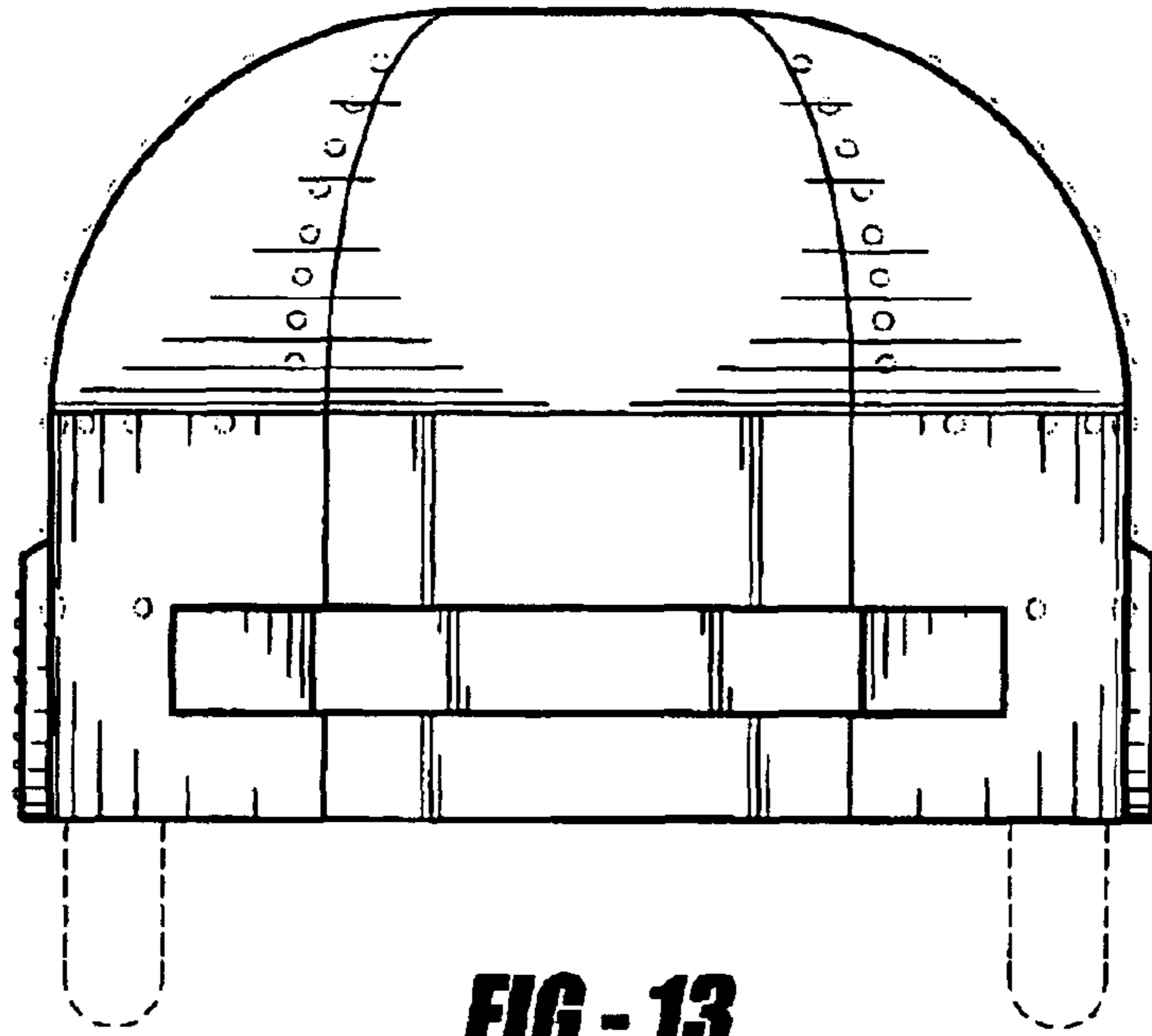

FIG - 13

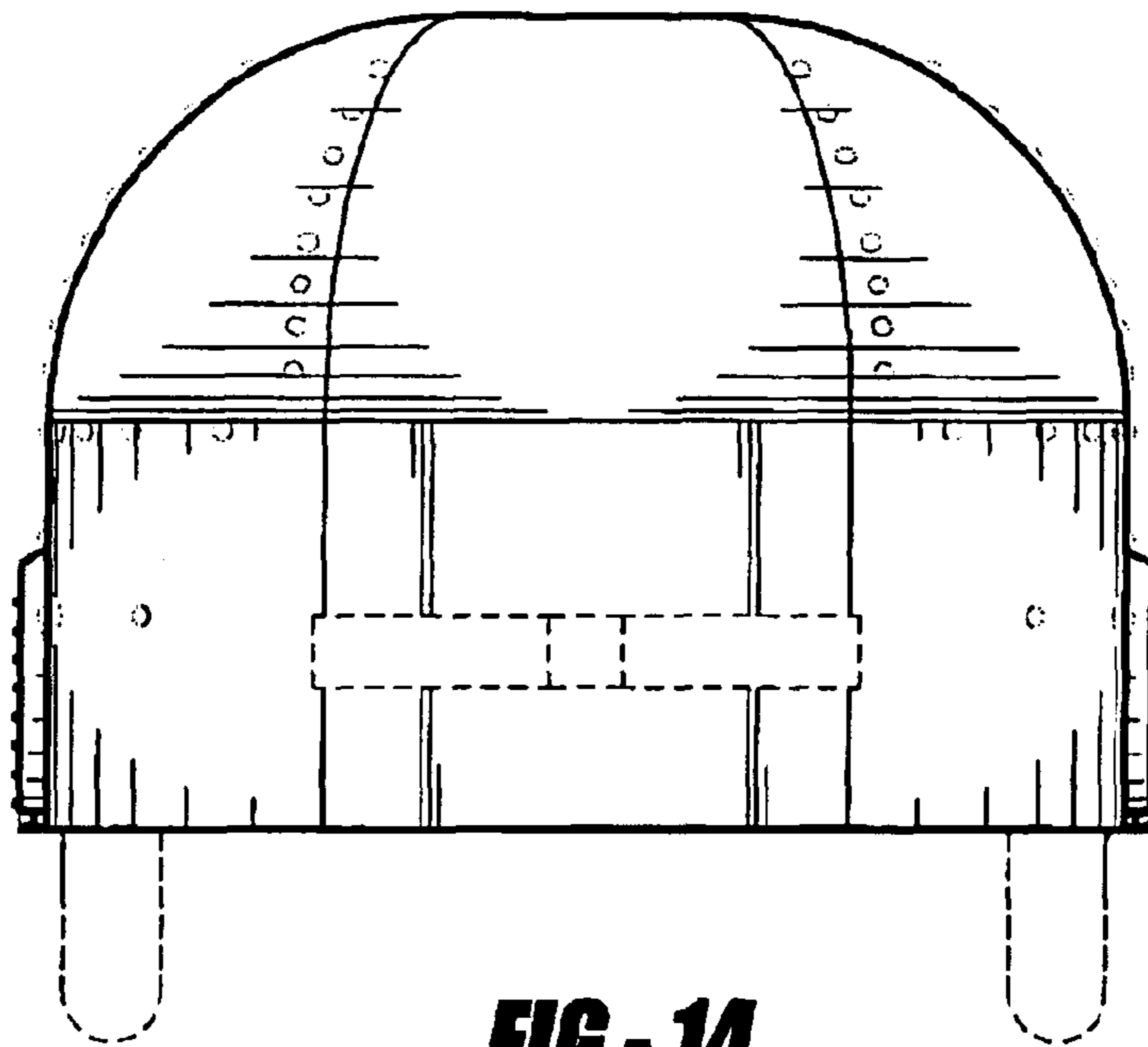

FIG - 14

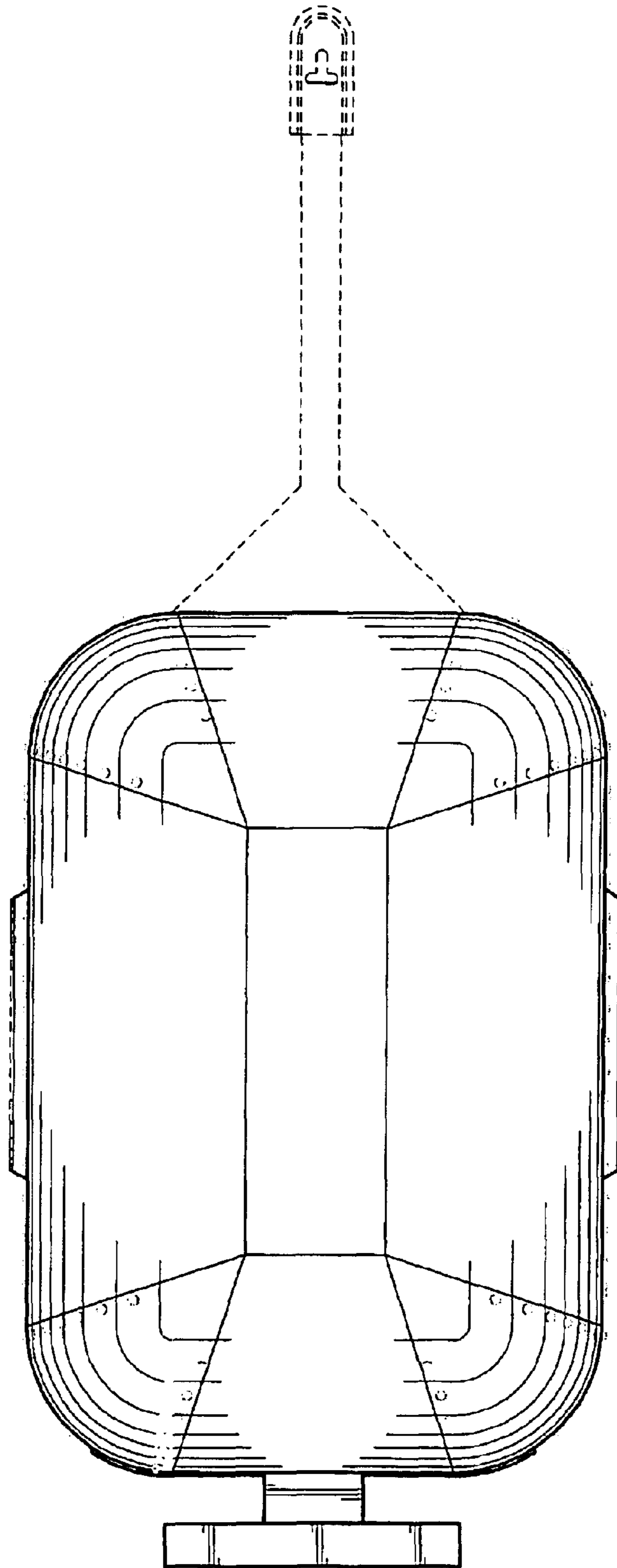

FIG - 15

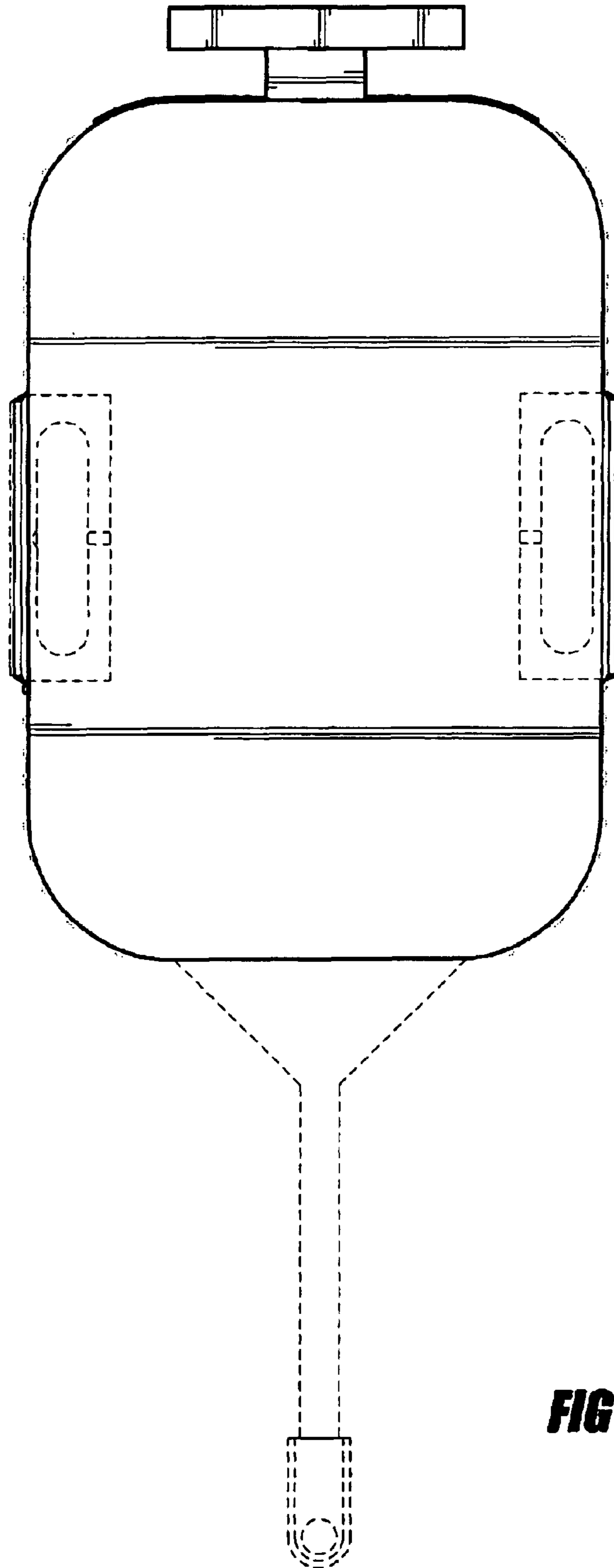

FIG - 16