

US00D507165S

(12) **United States Design Patent**
Kishi et al.

(10) **Patent No.:** **US D507,165 S**
(45) **Date of Patent:** **** Jul. 12, 2005**

(54) **STAPLE CARTRIDGE**

(75) Inventors: **Kazuhiko Kishi**, Tokyo (JP); **Toshio Shimizu**, Tokyo (JP); **Kazuo Higuchi**, Tokyo (JP)

(73) Assignee: **Max Kabushiki Kaisha (Max Co., Ltd.)**, Tokyo (JP)

(**) Term: **14 Years**

(21) Appl. No.: **29/200,139**

(22) Filed: **Feb. 25, 2004**

(30) **Foreign Application Priority Data**

Aug. 29, 2003 (JP) 2003-025344

(51) **LOC (8) Cl.** **19-02**

(52) **U.S. Cl.** **D8/49**

(58) **Field of Search** D8/49, 50, 61;
227/7, 120, 131, 132, 135, 136, 156

(56) **References Cited**

U.S. PATENT DOCUMENTS

- 5,474,222 A * 12/1995 Kanai et al. 227/131
- 6,039,230 A * 3/2000 Yagi et al. 227/136
- 6,568,579 B2 * 5/2003 Mochizuki 227/131
- D480,614 S * 10/2003 Haramiishi D8/49
- 2002/0017546 A1 * 2/2002 Takeuchi et al. 227/131

* cited by examiner

Primary Examiner—Adir Aronovich
(74) *Attorney, Agent, or Firm*—Burns, Doane, Swecker & Mathis, L.L.P.

(57) **CLAIM**

The ornamental design for a staple cartridge, as shown and described.

DESCRIPTION

FIG. 1 is a front, top perspective view of a staple cartridge showing our new design.

FIG. 2 is a bottom, rear perspective view thereof.

FIG. 3 is a front elevational view thereof.

FIG. 4 is a rear elevational view thereof.

FIG. 5 is a right side elevational view thereof; the left side being a mirror image thereof.

FIG. 6 is a top plan view thereof.

FIG. 7 is a bottom plan view thereof.

FIG. 8 is a front, top exploded perspective view thereof.

FIG. 9 is a cross-sectional view taken generally along the line 9—9 shown in FIG. 6; and,

FIG. 10 is a perspective cross-sectional view, with staples inserted in the staple cartridge.

The broken line showing of the staples inserted in the staple cartridge in FIG. 10 is for illustrative purposes only and forms no part of the claimed design.

The stipple shading illustrating the contrast throughout the views is limited to distinguish contours between the open and closed areas and does not represent any color, texture or material.

1 Claim, 5 Drawing Sheets

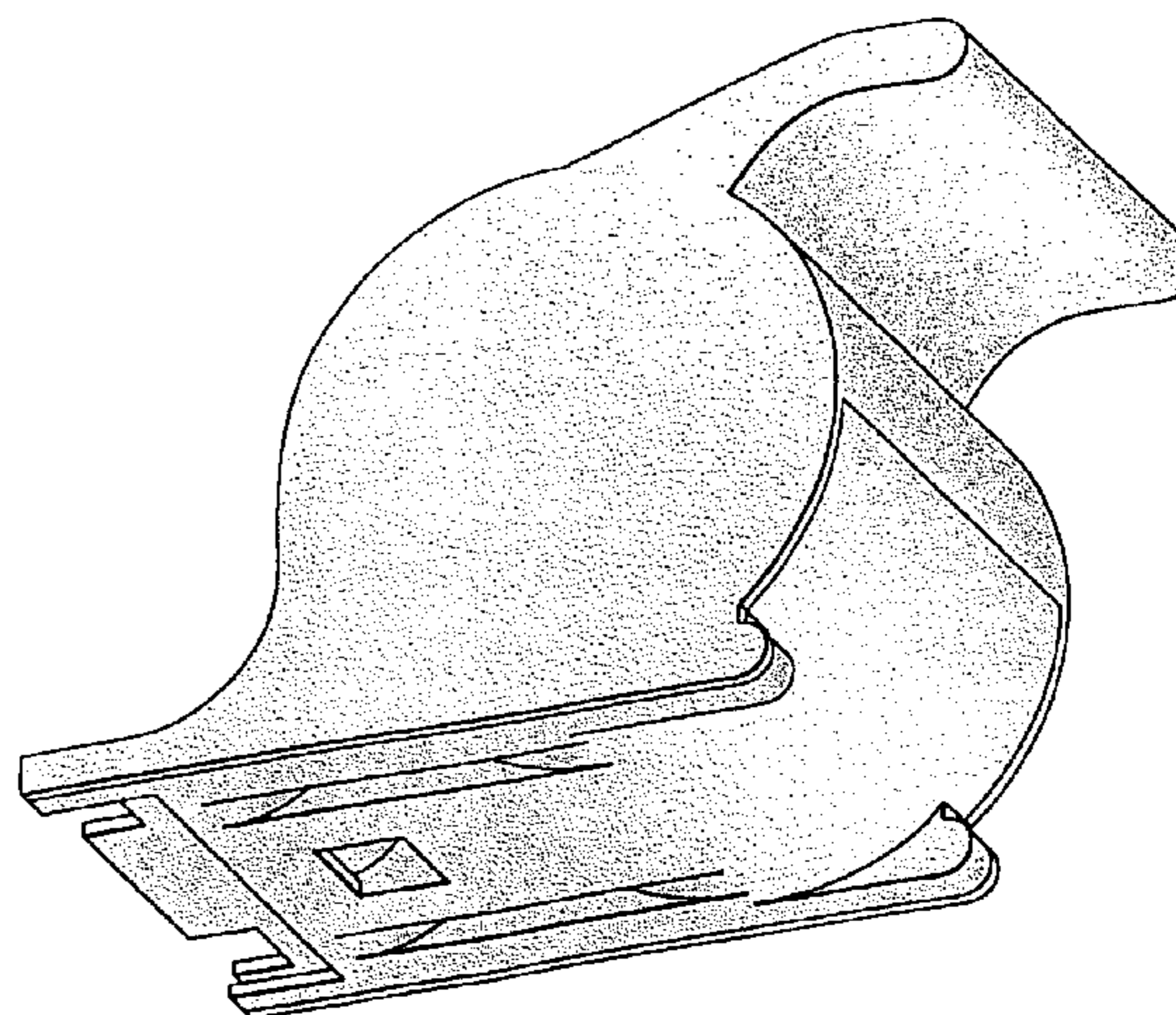
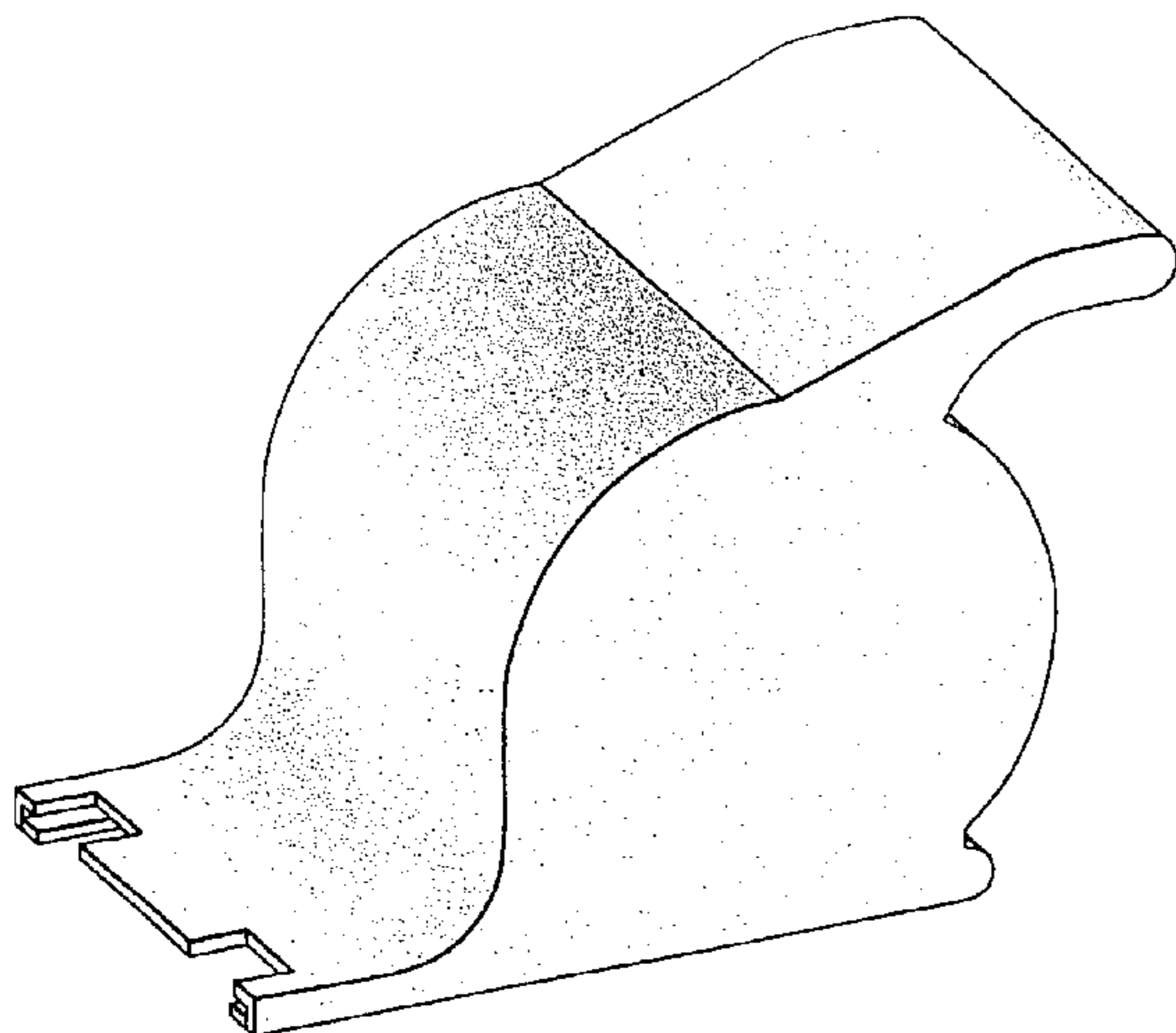

FIG. 1

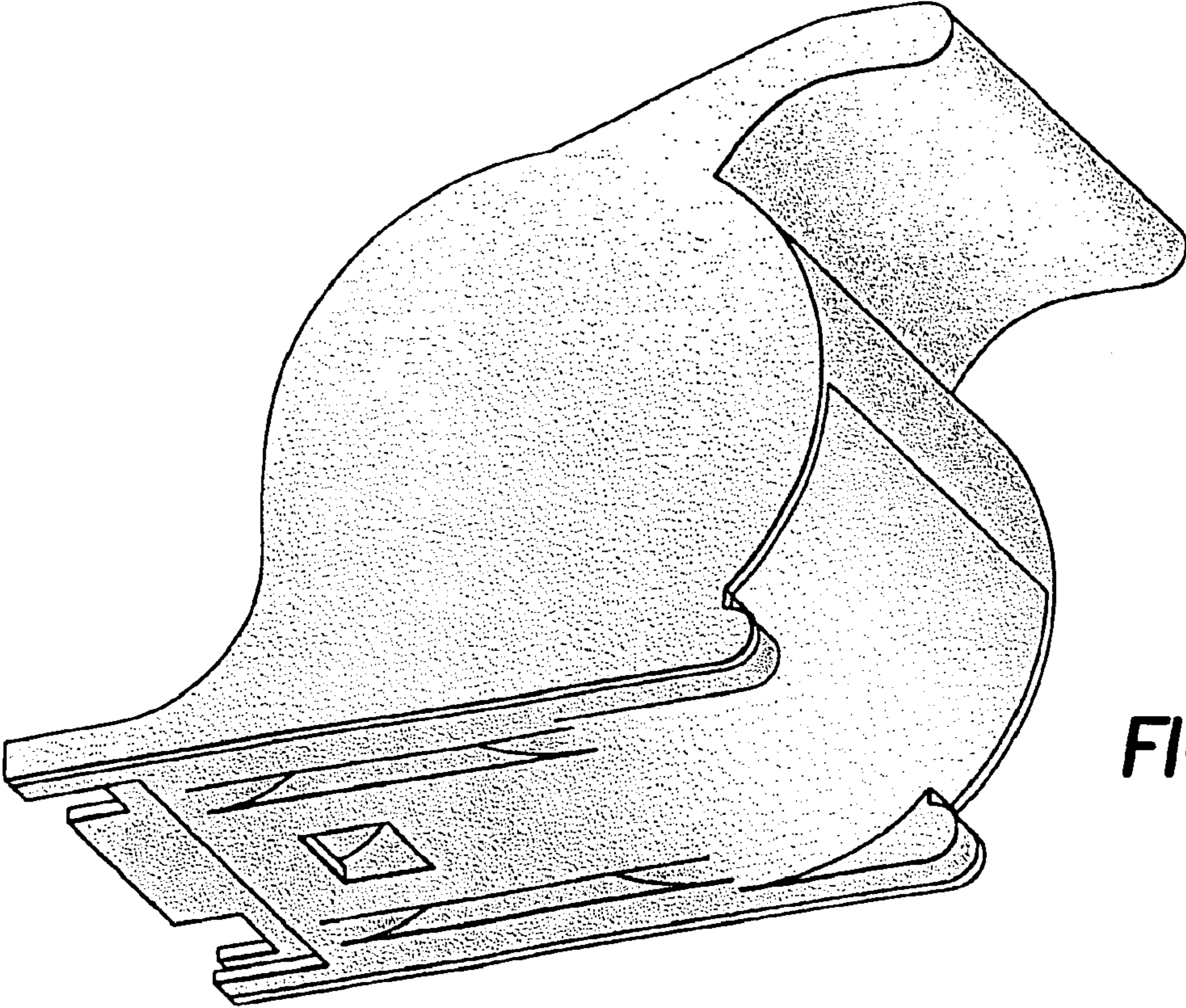
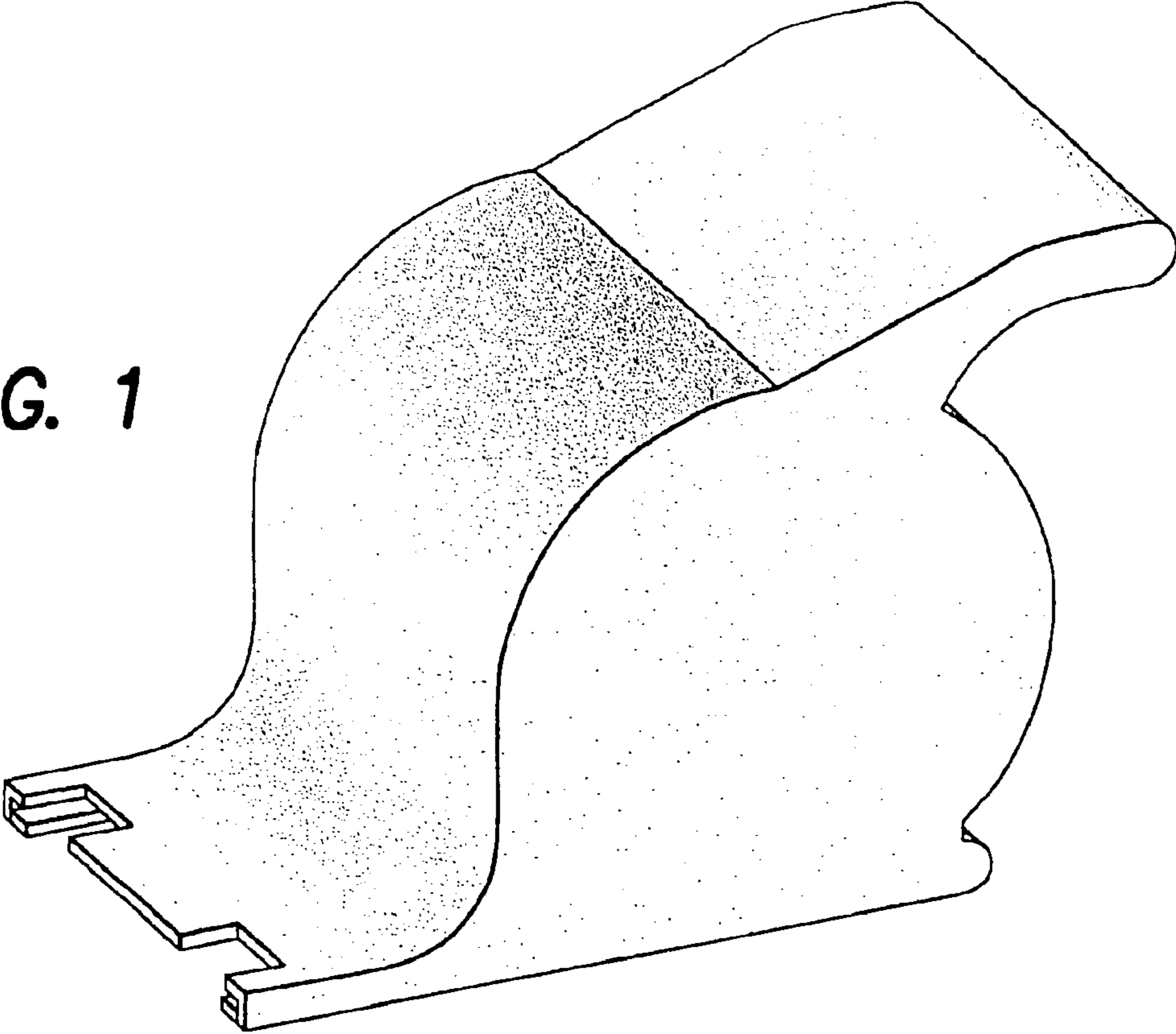

FIG. 2

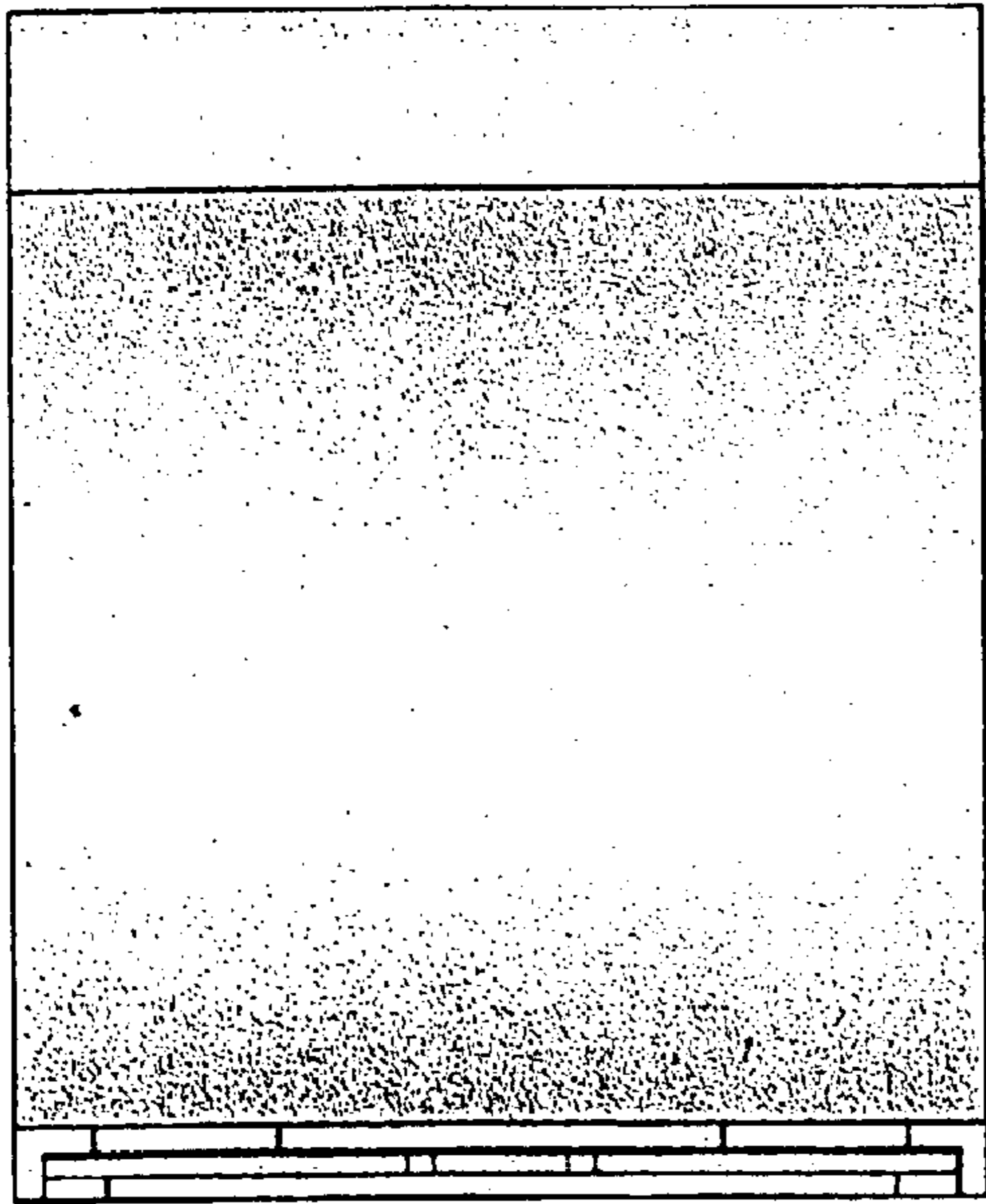

FIG. 3

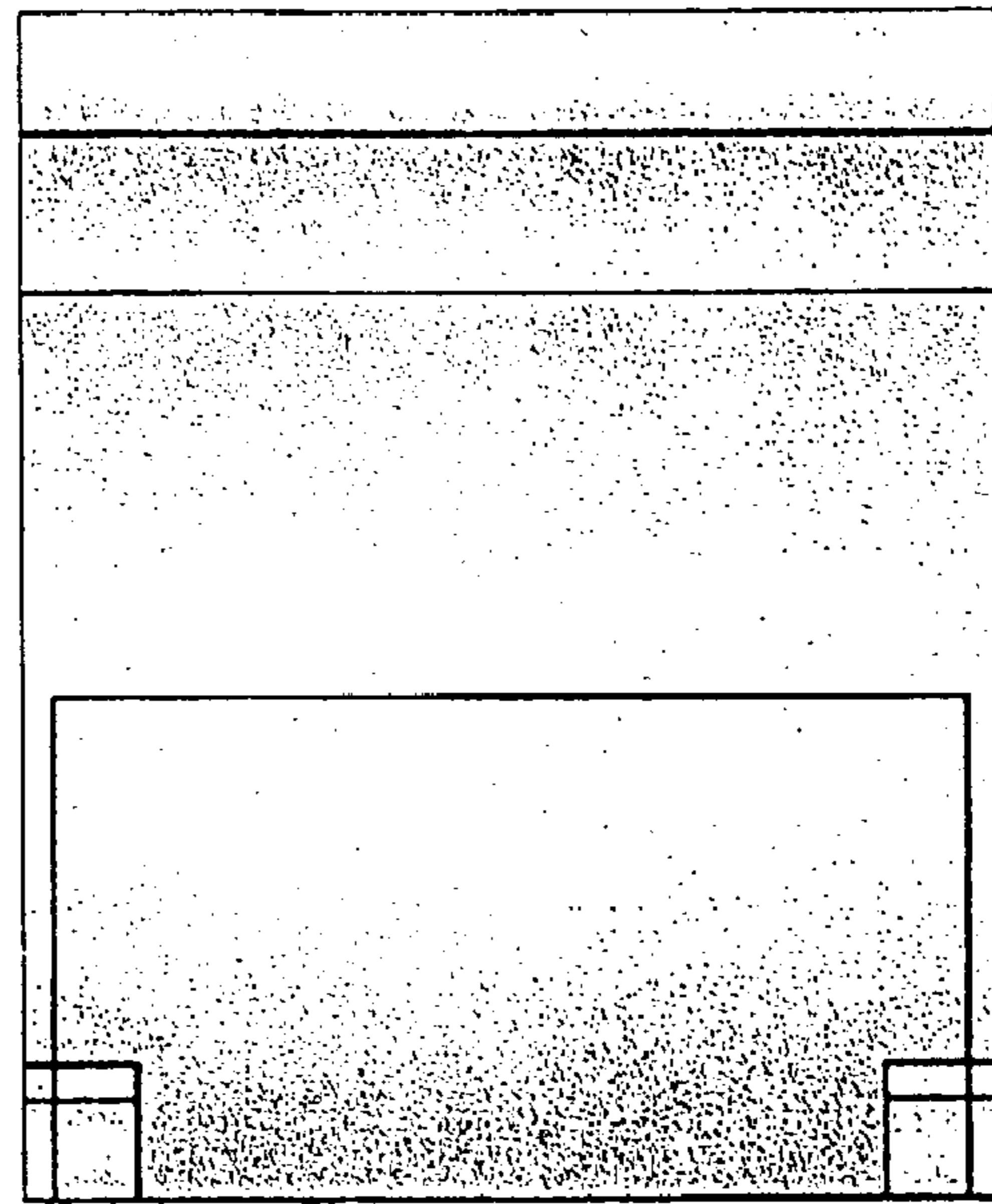

FIG. 4

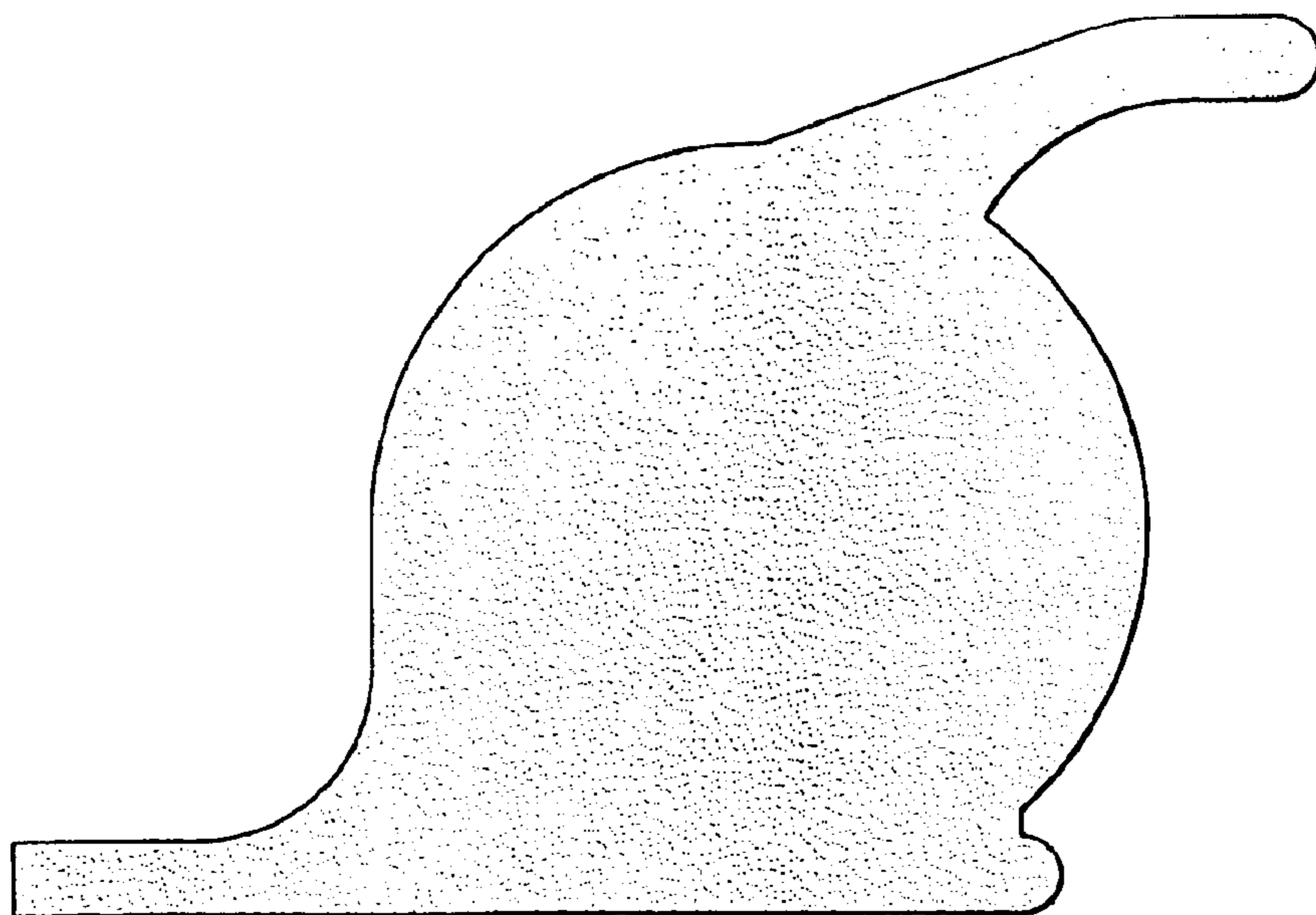
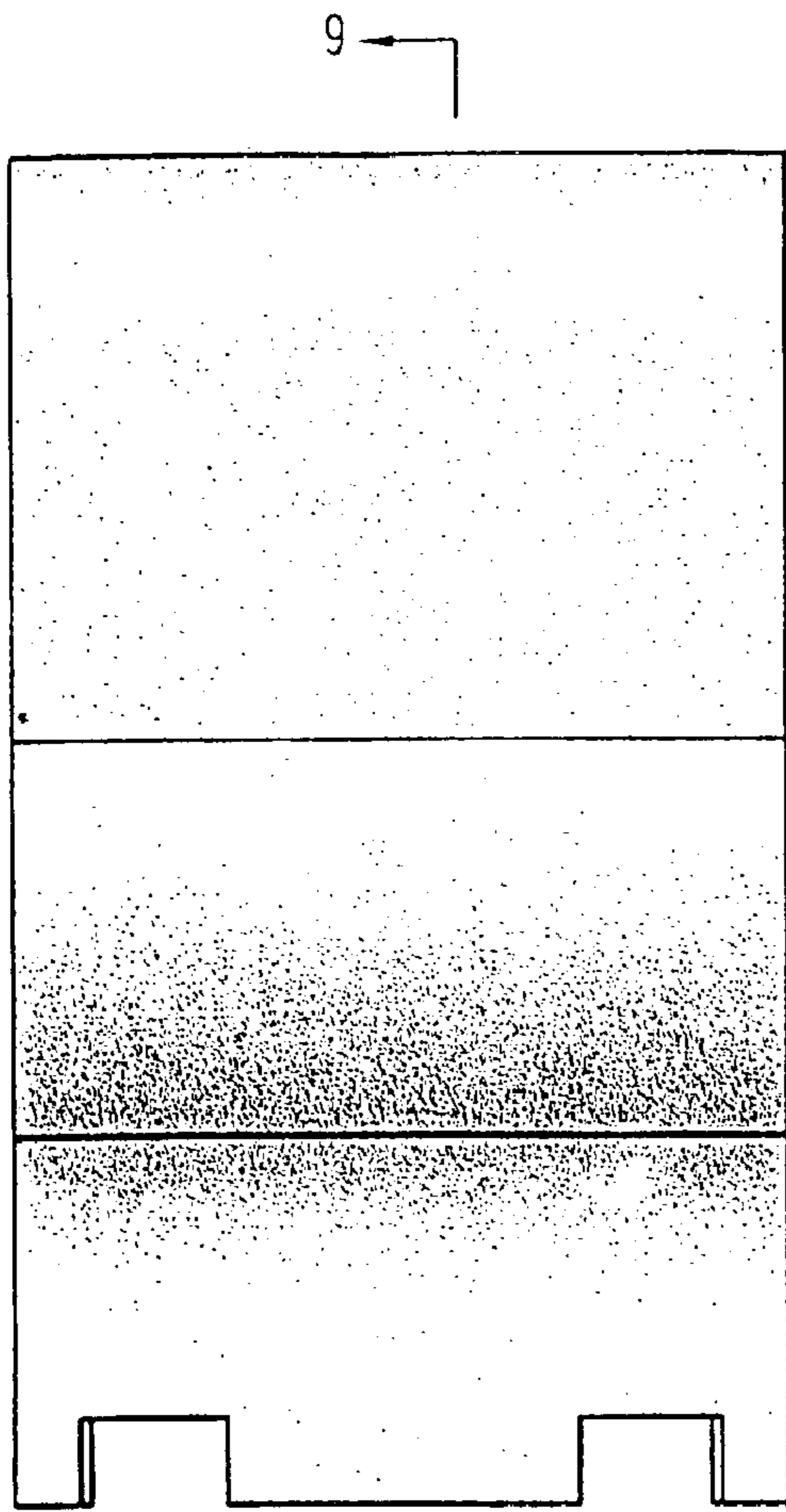

FIG. 5



9
FIG. 6

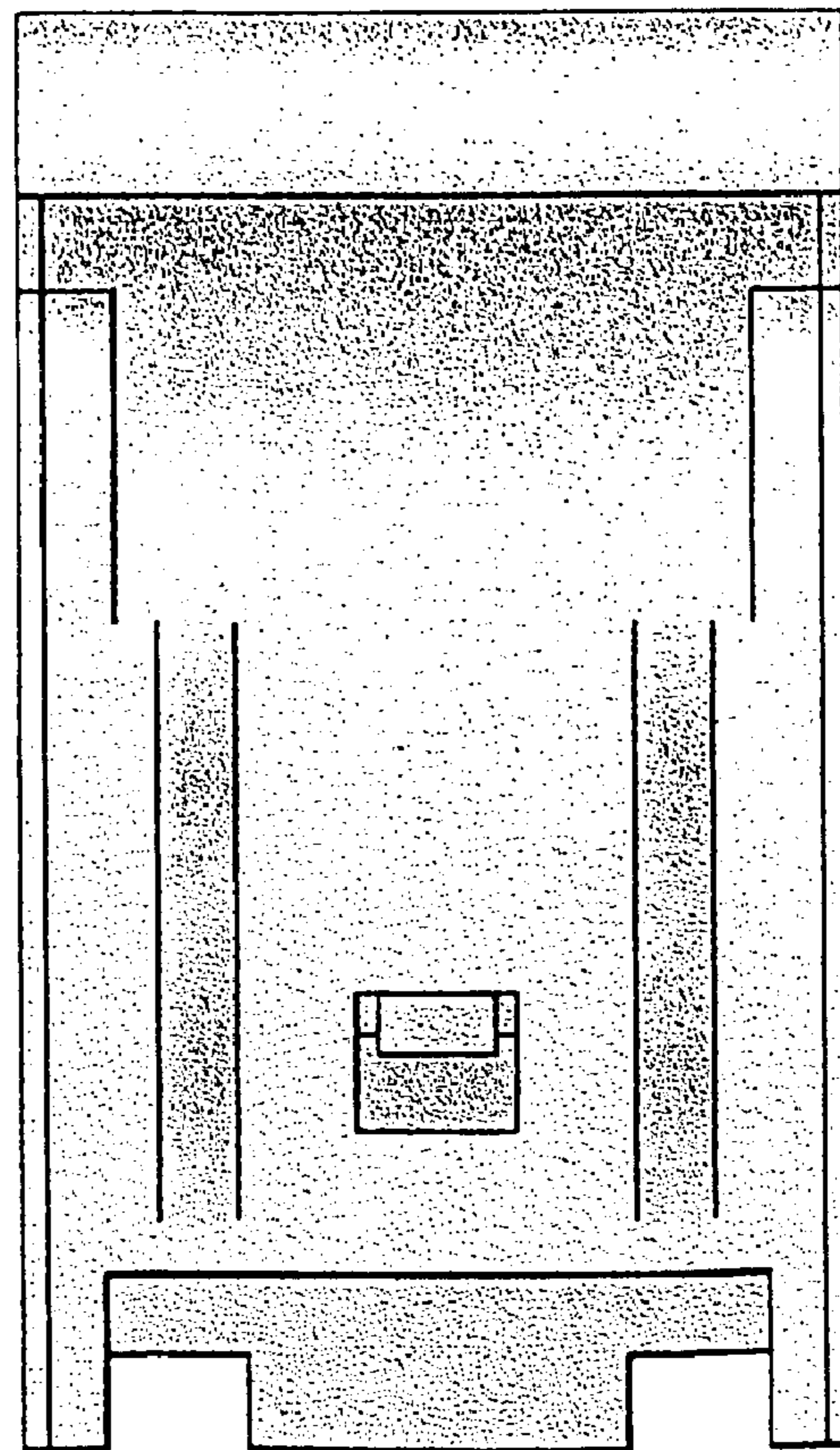

FIG. 7

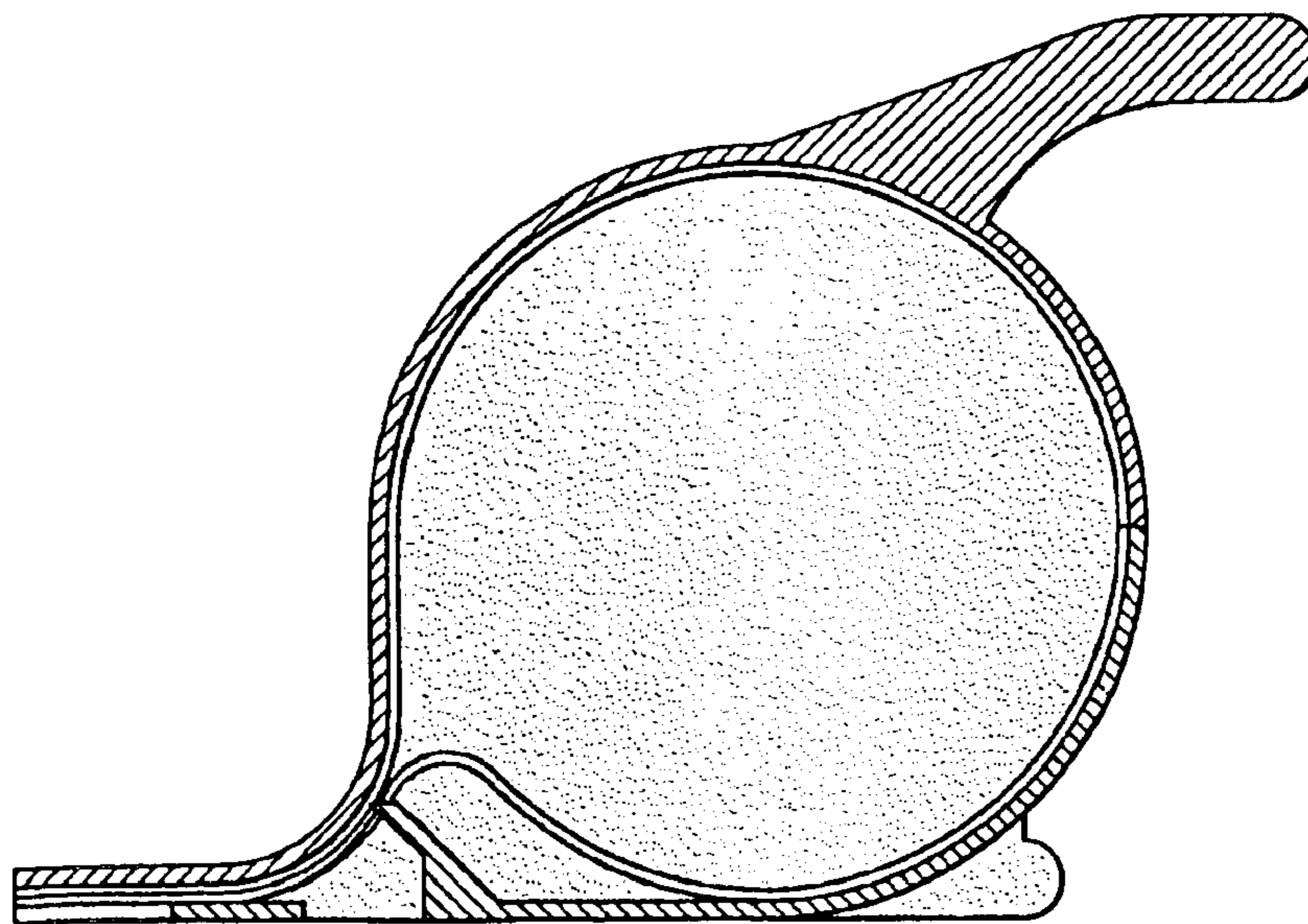
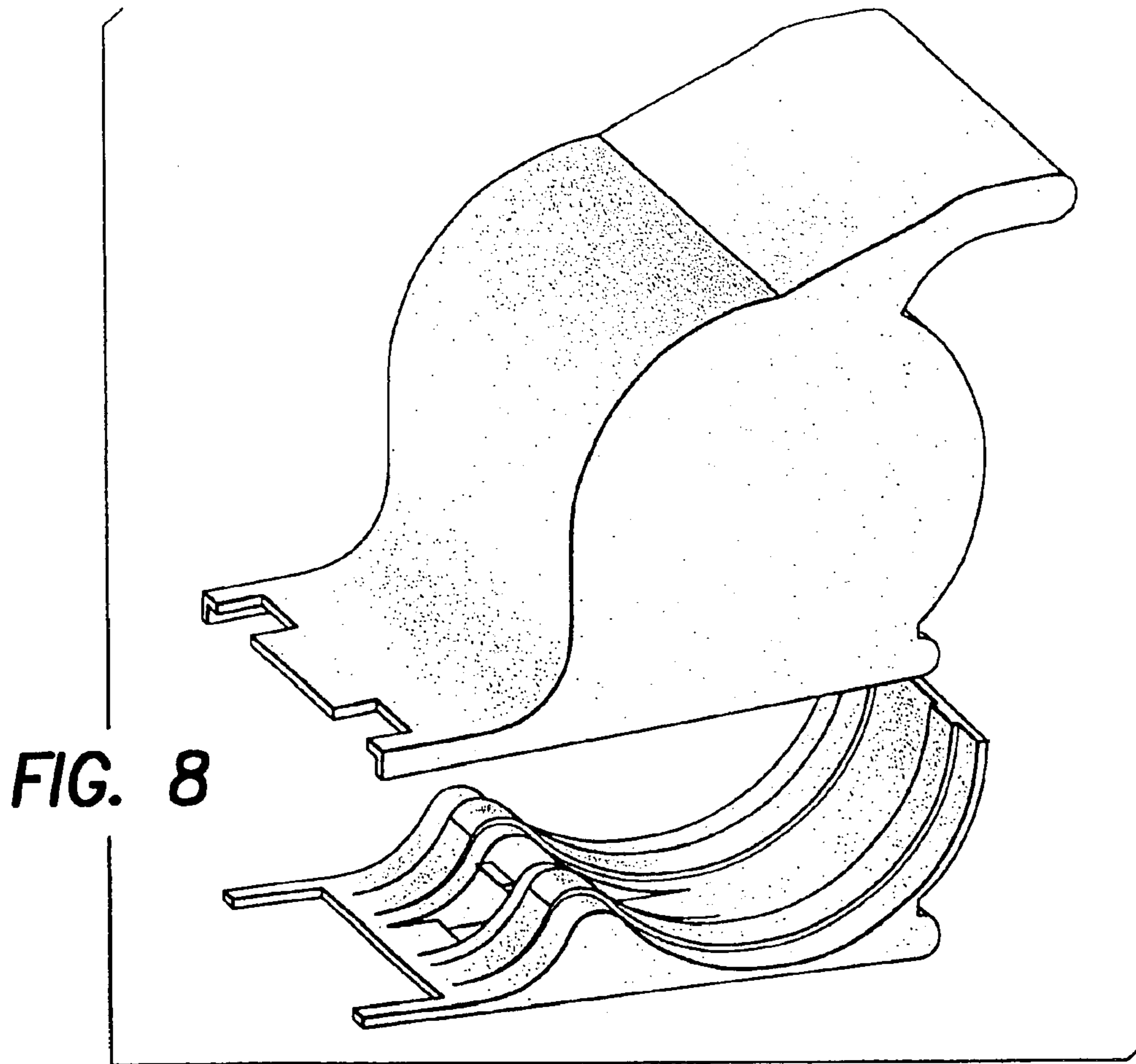

FIG. 9

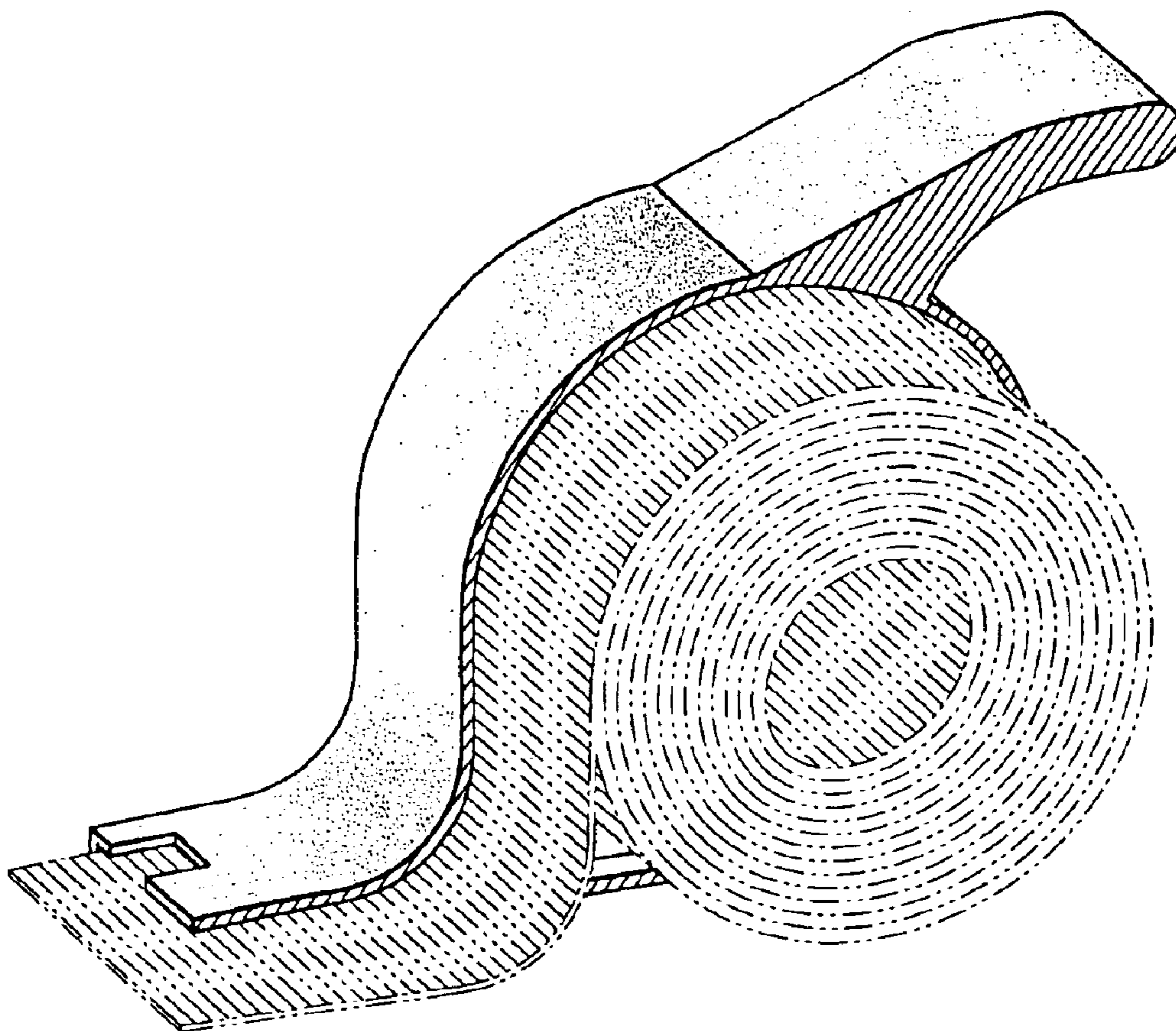

FIG. 10