



US00D506891S

(12) **United States Design Patent** (10) **Patent No.:** **US D506,891 S**
Paus (45) **Date of Patent:** **** Jul. 5, 2005**

(54) **FURNITURE POST**

(75) Inventor: **Michael J. Paus**, High Point, NC (US)

(73) Assignee: **Thomasville Furniture Industries, Inc.**, Thomasville, NC (US)

(**) Term: **14 Years**

(21) Appl. No.: **29/205,297**

(22) Filed: **May 12, 2004**

(51) **LOC (8) Cl.** **06-06**

(52) **U.S. Cl.** **D6/495**

(58) **Field of Search** D6/432, 436-441,
D6/445-448, 470, 491, 495; 312/114, 204,
224

(56) **References Cited**

U.S. PATENT DOCUMENTS

| | | | | | |
|------------|---|---------|-----------------|-------|--------|
| D24,598 S | * | 8/1895 | Mohring | | D6/448 |
| D249,860 S | * | 10/1978 | Ungaro | | D6/435 |
| D250,234 S | * | 11/1978 | Ungaro | | D6/436 |
| D379,126 S | * | 5/1997 | Keller | | D6/495 |
| D385,133 S | * | 10/1997 | Myers | | D6/497 |
| D422,167 S | * | 4/2000 | Vaaler | | D6/495 |
| D423,257 S | * | 4/2000 | Paus | | D6/495 |
| D456,646 S | * | 5/2002 | McDaniel et al. | | D6/495 |

OTHER PUBLICATIONS

Post on Server, Chesapeake Collection brochure, Lexington Furniture Industries, p. 25, 1994.

Chest of Drawers, Christie, Manson and Woods, Ltd., p. 81 of unknown publication, 1780-1800.

E15, D9, E2, D4, C16 and D12, Britain/Chests of Drawers, p. 242 (E15), p. 243 (D9, E2, D4, and C16) and p. 244 (D12), date unknown, available as of the filing date.

Post on Door Dresser, Santa Fe Collection brochure, Thomasville Furniture Industries, Inc., p. 7, date unknown, available as of the filing date.

Post on Dresser, Santiago Collection brochure, Thomasville Furniture Industries, Inc., p. 7, 1999.

* cited by examiner

Primary Examiner—Cathron C. Brooks

(74) *Attorney, Agent, or Firm*—Womble Carlyle Sandridge & Rice, PLLC

(57) **CLAIM**

The ornamental design for a furniture post, as shown and described.

DESCRIPTION

FIG. 1 is a front side perspective view of a first embodiment of a furniture post showing my new design;

FIG. 2 is a front elevational view thereof;

FIG. 3 is a left side view;

FIG. 4 is a front elevational view thereof, and including broken lines indicating representative environmental elements;

FIG. 5 is a top view thereof, and including broken lines indicating representative environmental elements;

FIG. 6 is a top view of a second embodiment of a furniture post showing my new design, and including broken lines indicating representative environmental elements; and,

FIG. 7 is a perspective view of the second embodiment.

The sole difference between the two embodiments resides in the curved front of the upper portion of the post in the second embodiment, as best seen in FIG. 6.

The views of the furniture post not shown form no part of the claimed design. The broken lines depicting a dresser in FIG. 4, and the portions of the top of the dresser shown in FIGS. 5 and 6, represent environmental elements only and form no part of the claimed design. The separation and bracket indicate, for ease of illustration, that the precise height of the furniture post is not claimed.

1 Claim, 3 Drawing Sheets

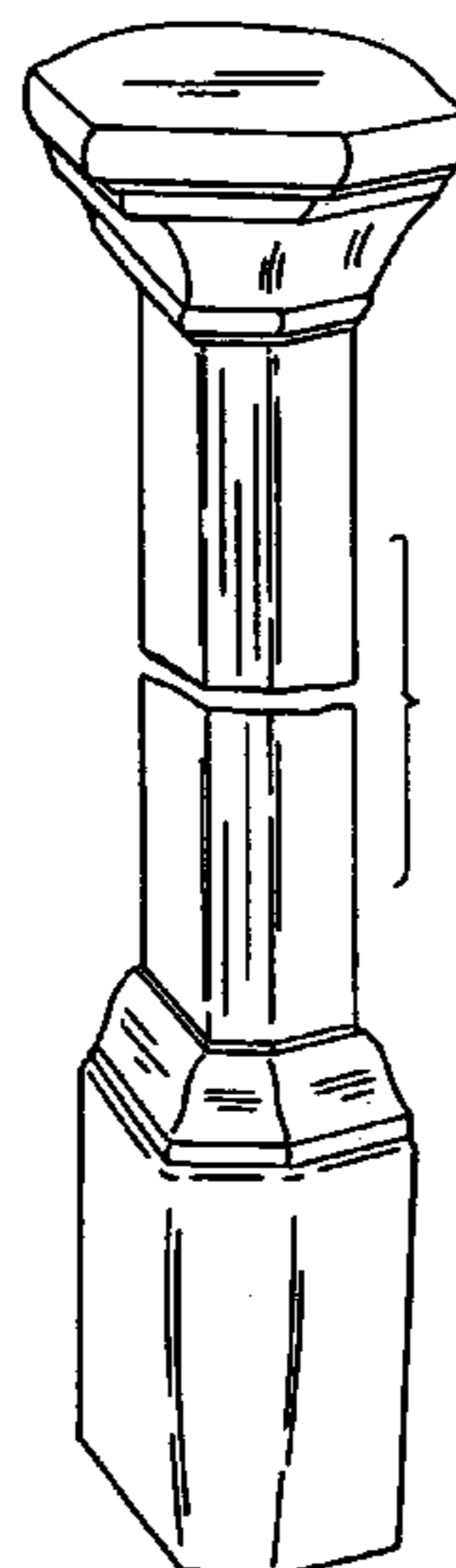

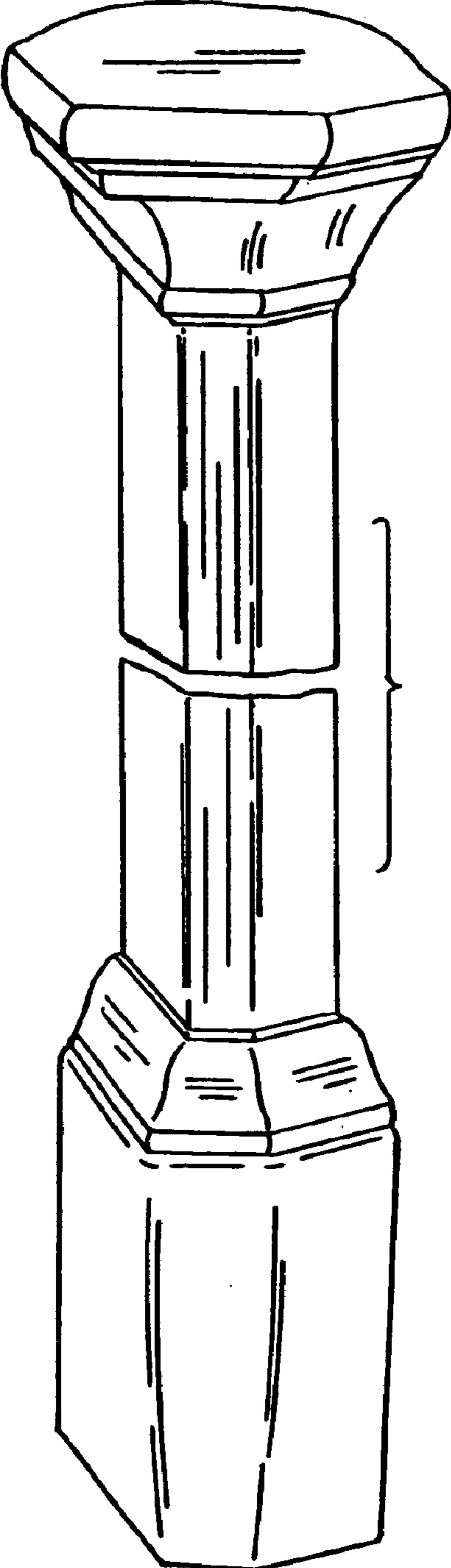

FIG. 1

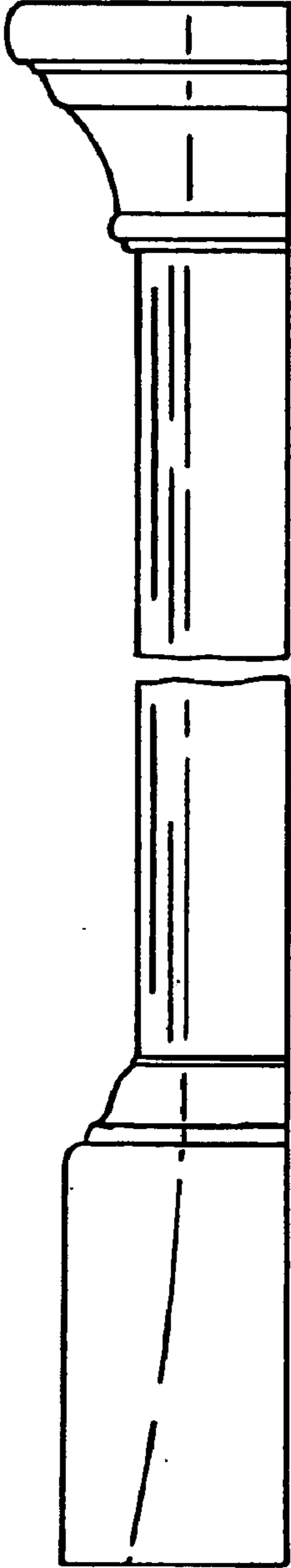

FIG. 2

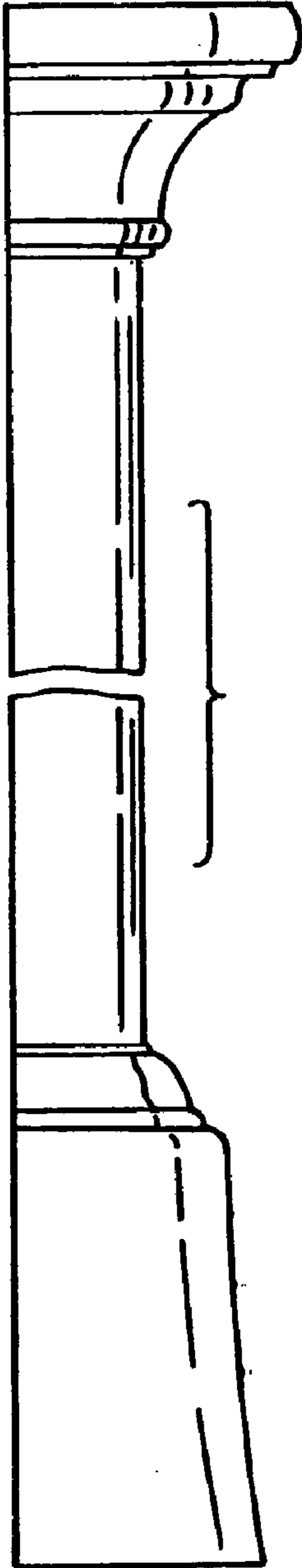

FIG. 3

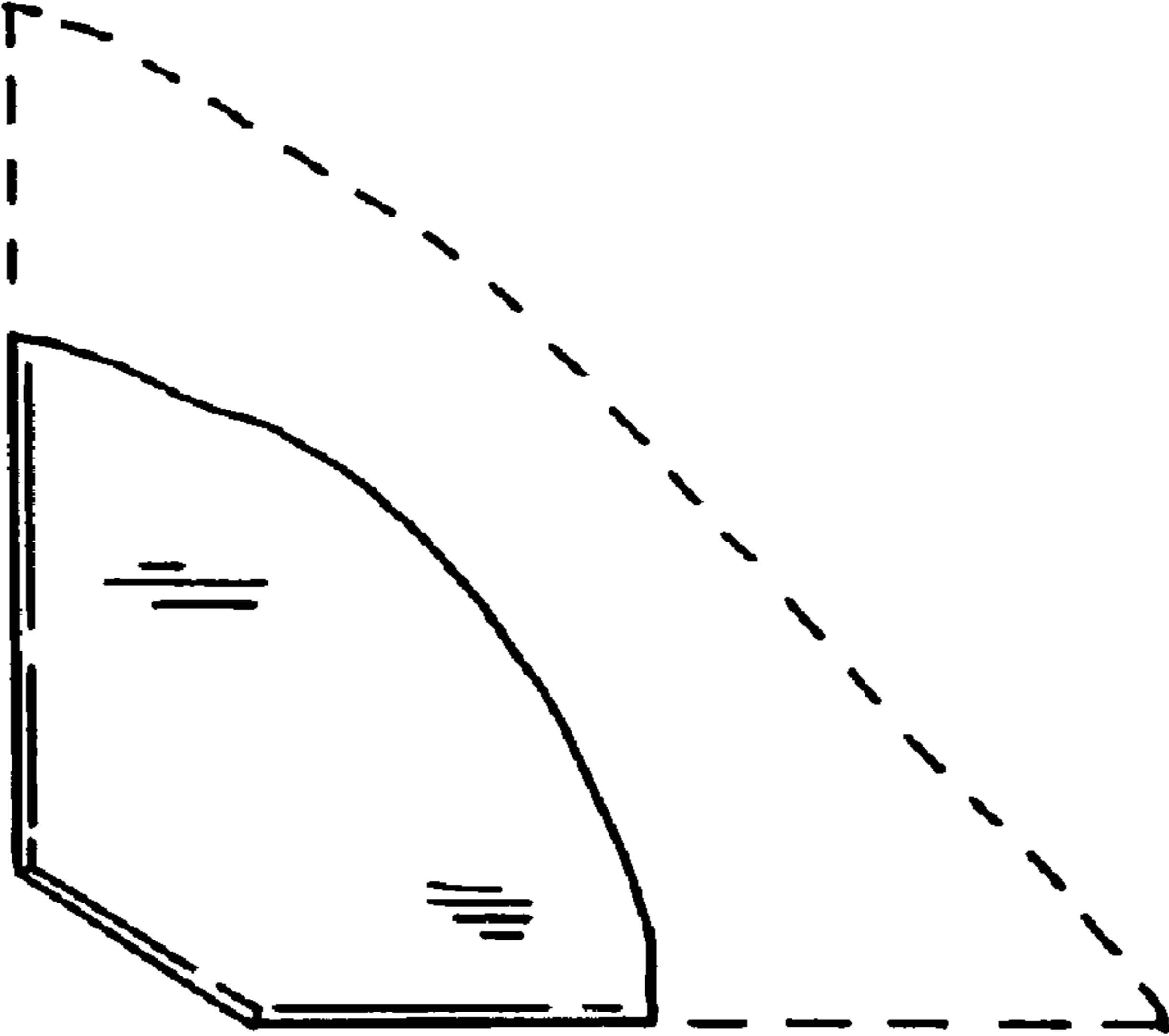

FIG. 5

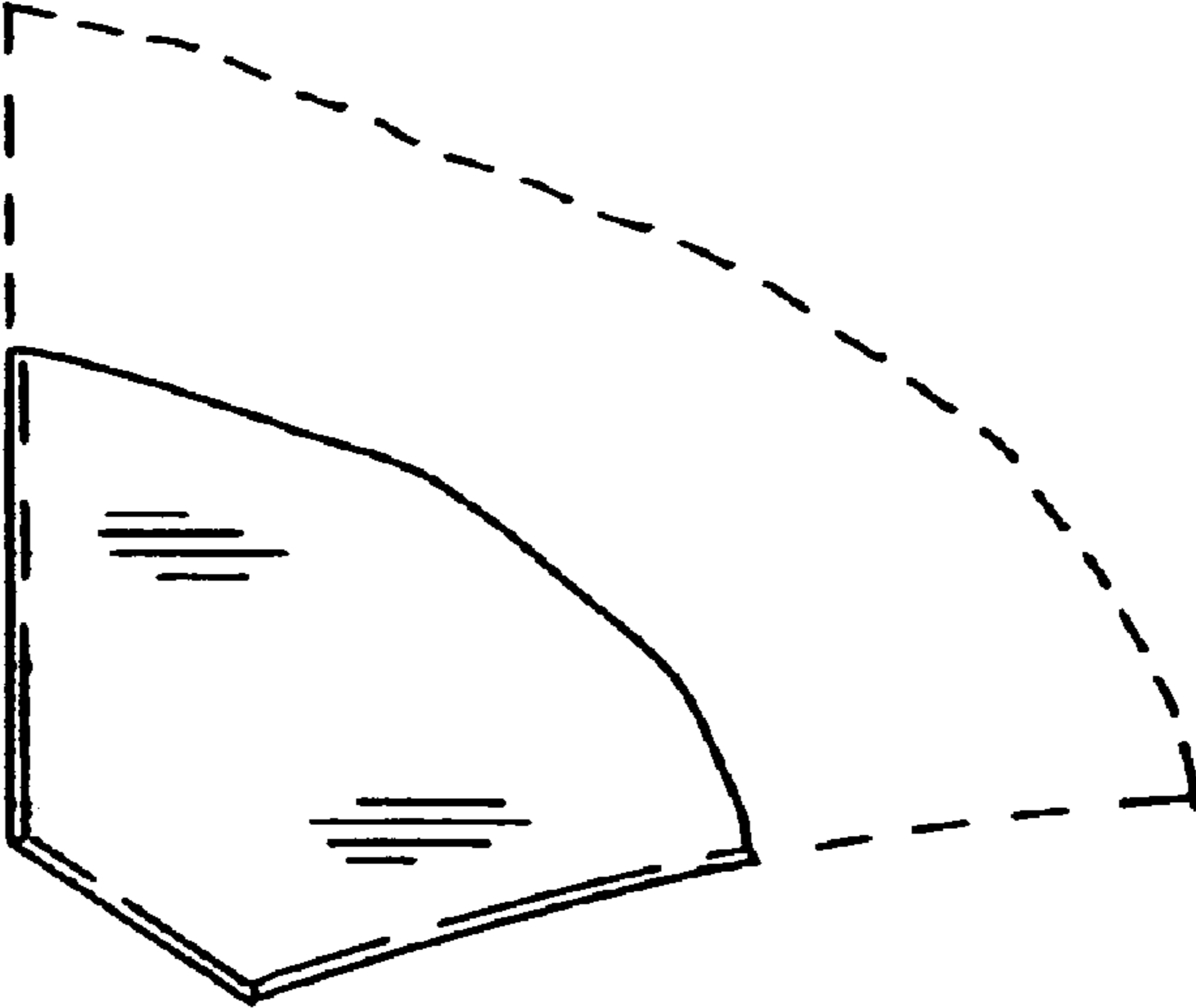

FIG. 6

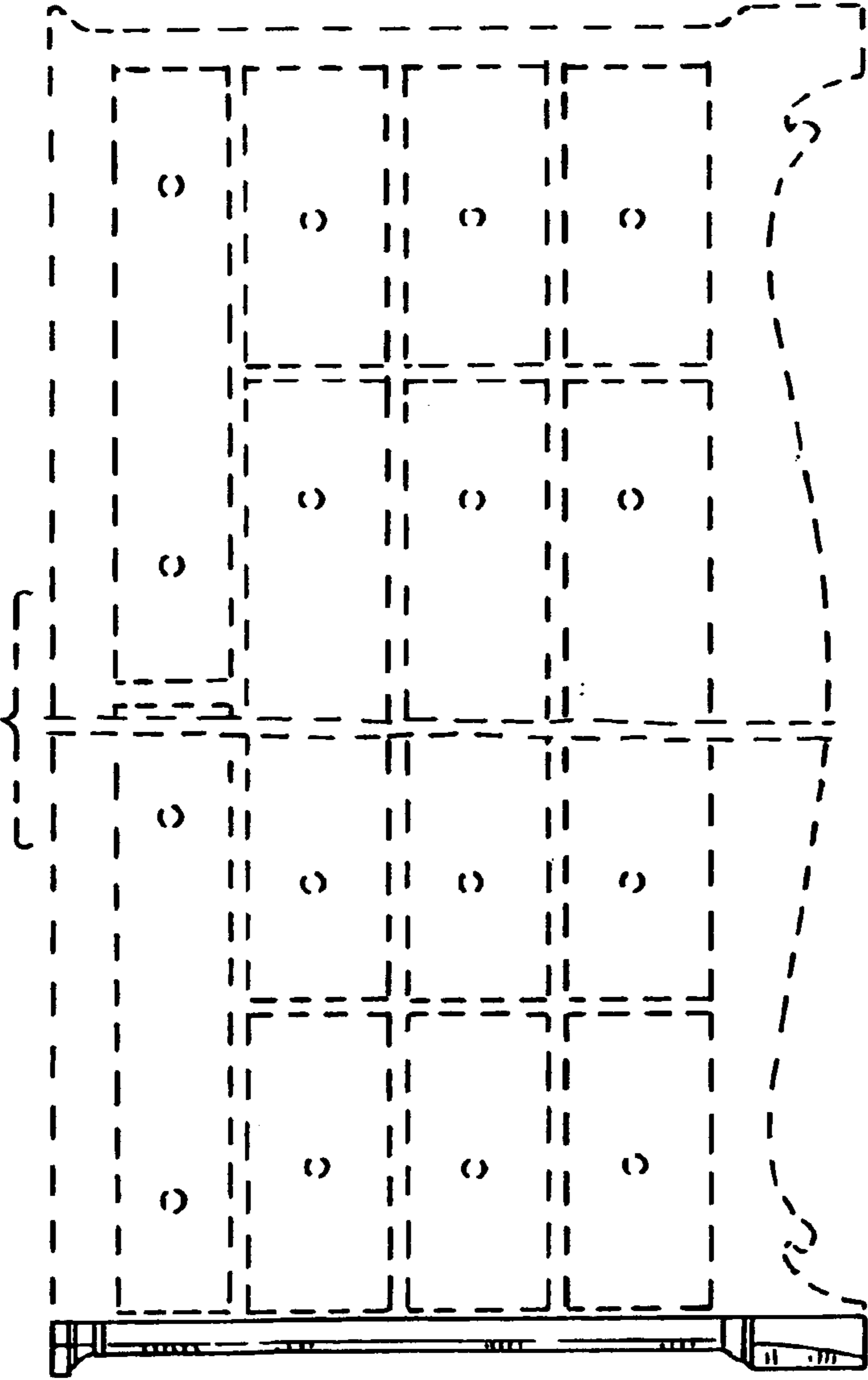
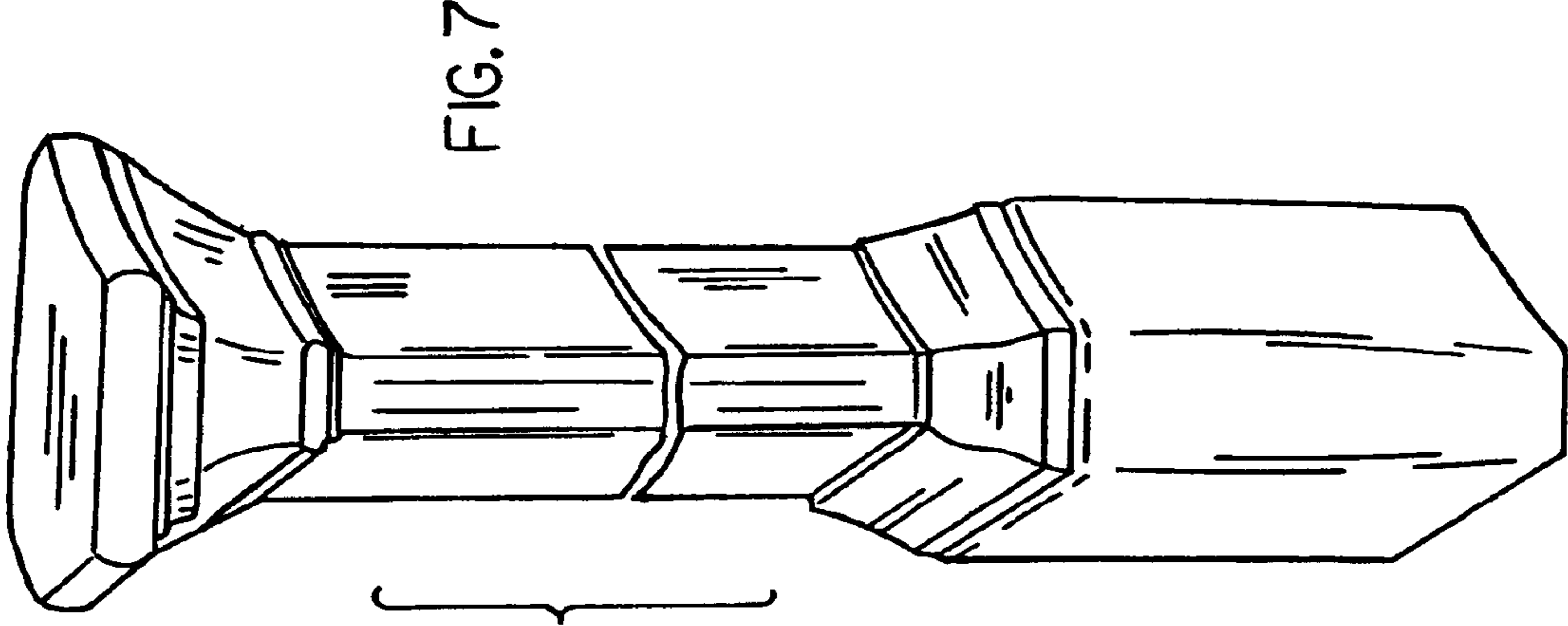

FIG. 4