

US00D506423S

(12) **United States Design Patent**  
**Matsumoto**

(10) **Patent No.: US D506,423 S**  
(45) **Date of Patent: \*\* Jun. 21, 2005**

(54) **LINING PAD OF DISK BRAKE FOR VEHICLE**

(75) Inventor: **Yutaka Matsumoto, Ueda (JP)**

(73) Assignee: **Nissin Kogyo Co., Ltd., Nagano-Ken (JP)**

(\*\*) Term: **14 Years**

(21) Appl. No.: **29/202,318**

(22) Filed: **Mar. 30, 2004**

(30) **Foreign Application Priority Data**

Sep. 30, 2003 (JP) ..... 2003-028598

(51) **LOC (8) Cl. .... 12-16**

(52) **U.S. Cl. .... D12/180**

(58) **Field of Search .... D12/180; 188/73.3, 188/73.31-73.39, 73.43, 73.45, 218 XL, 250 B, 250 E, 250 G**

(56) **References Cited**

**U.S. PATENT DOCUMENTS**

- D270,824 S \* 10/1983 Robinette ..... D12/180
- D277,175 S \* 1/1985 Caplygin ..... D12/180
- D359,020 S \* 6/1995 Steinke et al. .... D12/180
- D368,453 S \* 4/1996 Steinke et al. .... D12/180
- D417,642 S \* 12/1999 Ashley, Sr. .... D12/180

- 6,367,600 B1 \* 4/2002 Arbesman ..... 188/250 G
- 6,374,959 B1 \* 4/2002 Kay ..... 188/73.1
- 6,481,544 B2 \* 11/2002 Brecht et al. .... 188/250 E
- D466,846 S \* 12/2002 Krivenkoff ..... D12/180

**FOREIGN PATENT DOCUMENTS**

JP 11 52 167 9/2002

\* cited by examiner

*Primary Examiner*—Melody N. Brown

(74) *Attorney, Agent, or Firm*—Sughrue Mion, PLLC

(57) **CLAIM**

The ornamental design for a lining pad of disk brake for vehicle, as shown and described.

**DESCRIPTION**

FIG. 1 is a perspective view of the top, front and left side of a lining pad of disk brake for vehicle showing my new design;

FIG. 2 is a front elevational view thereof;

FIG. 3 is a rear elevational view thereof;

FIG. 4 is a top plan view thereof;

FIG. 5 is a bottom plan view thereof; and,

FIG. 6 is a left side elevational view thereof, the right side elevational view being a mirror image thereof.

The elements shown in broken lines are for illustrative purposes only and form no part of the claimed design.

**1 Claim, 3 Drawing Sheets**

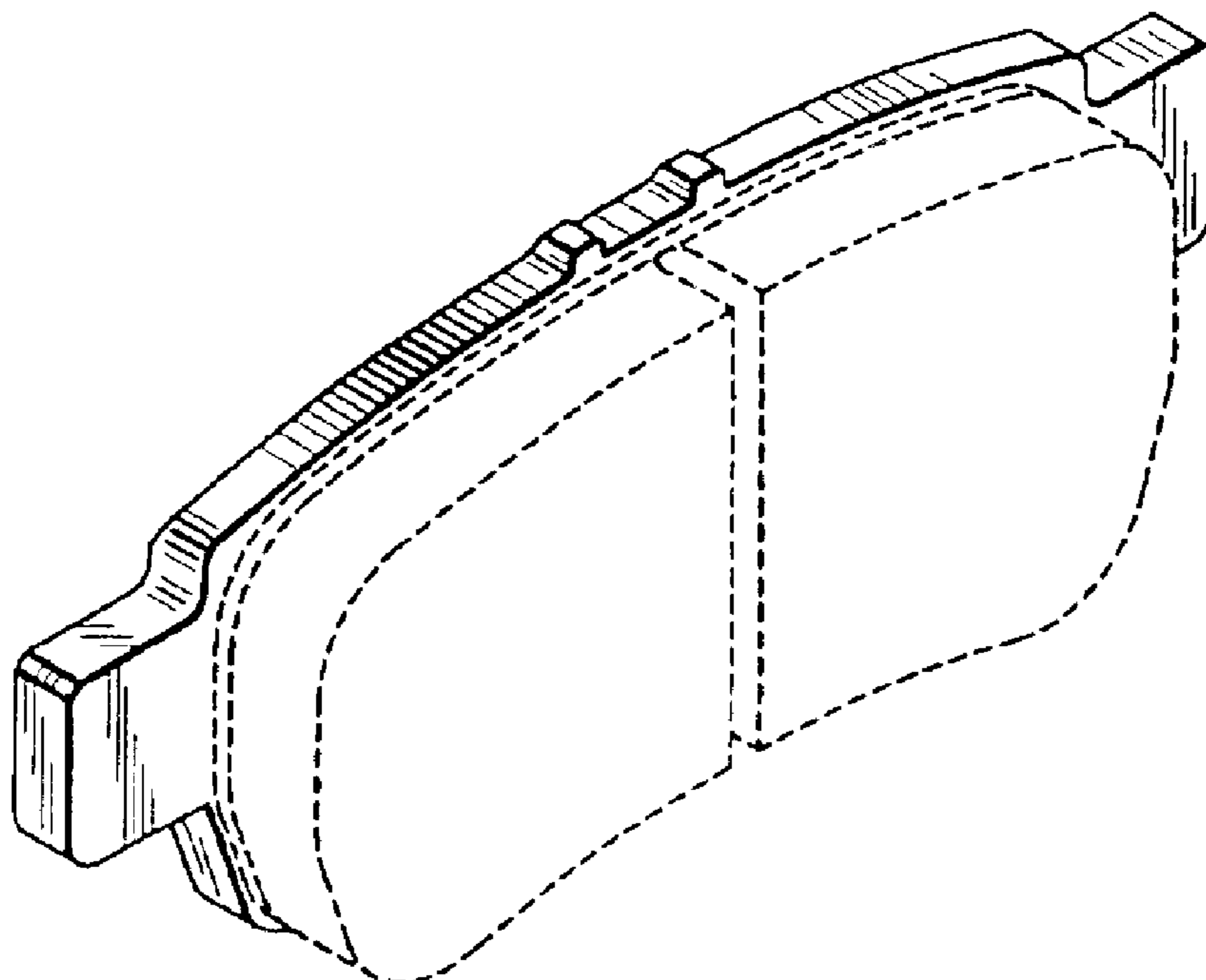

FIG. 1

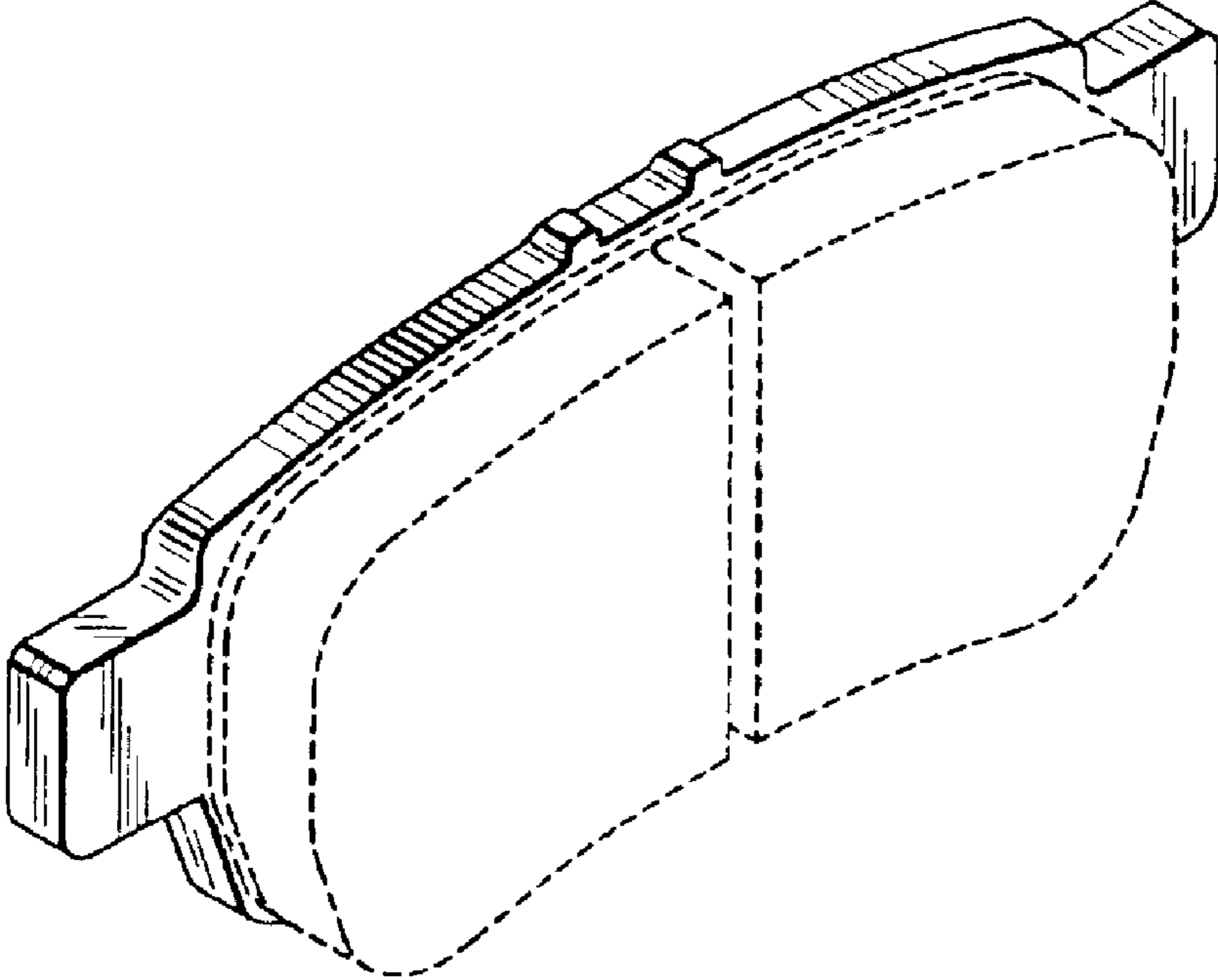

FIG.2

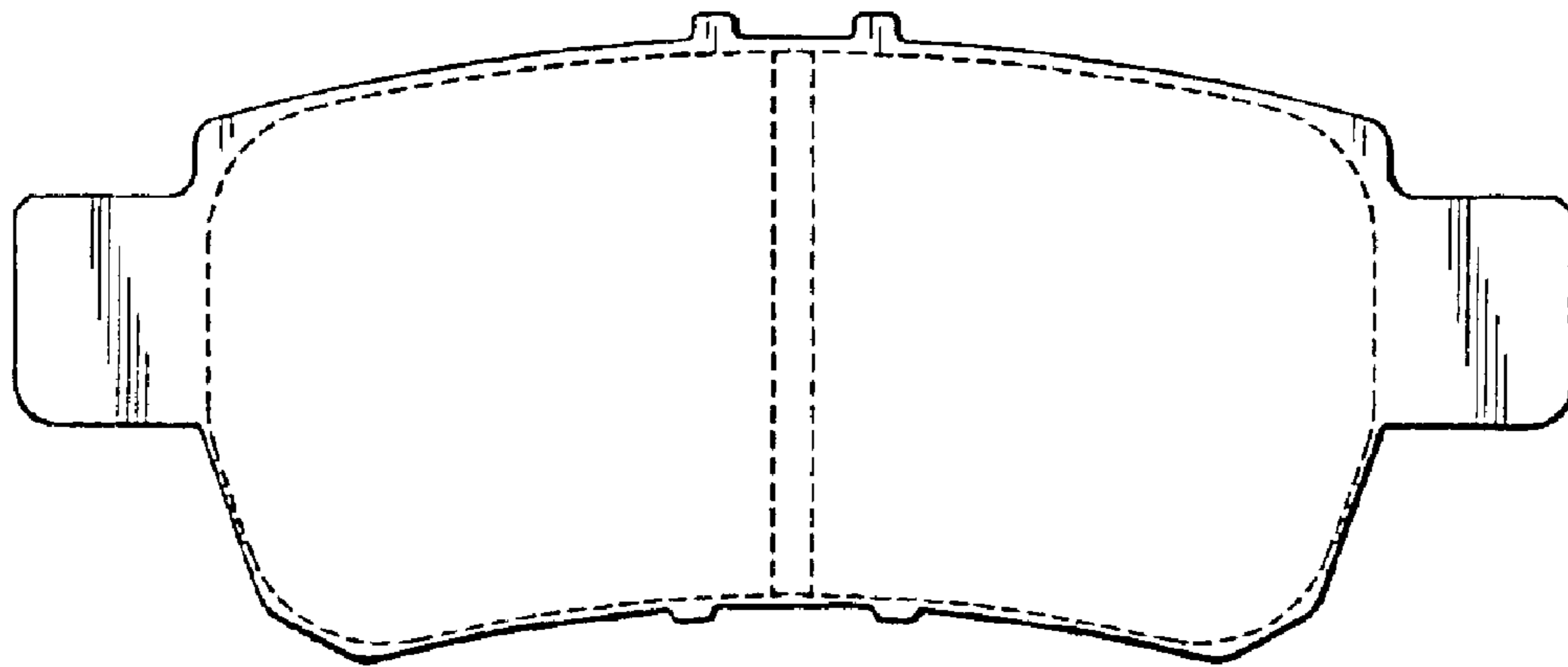

FIG.3

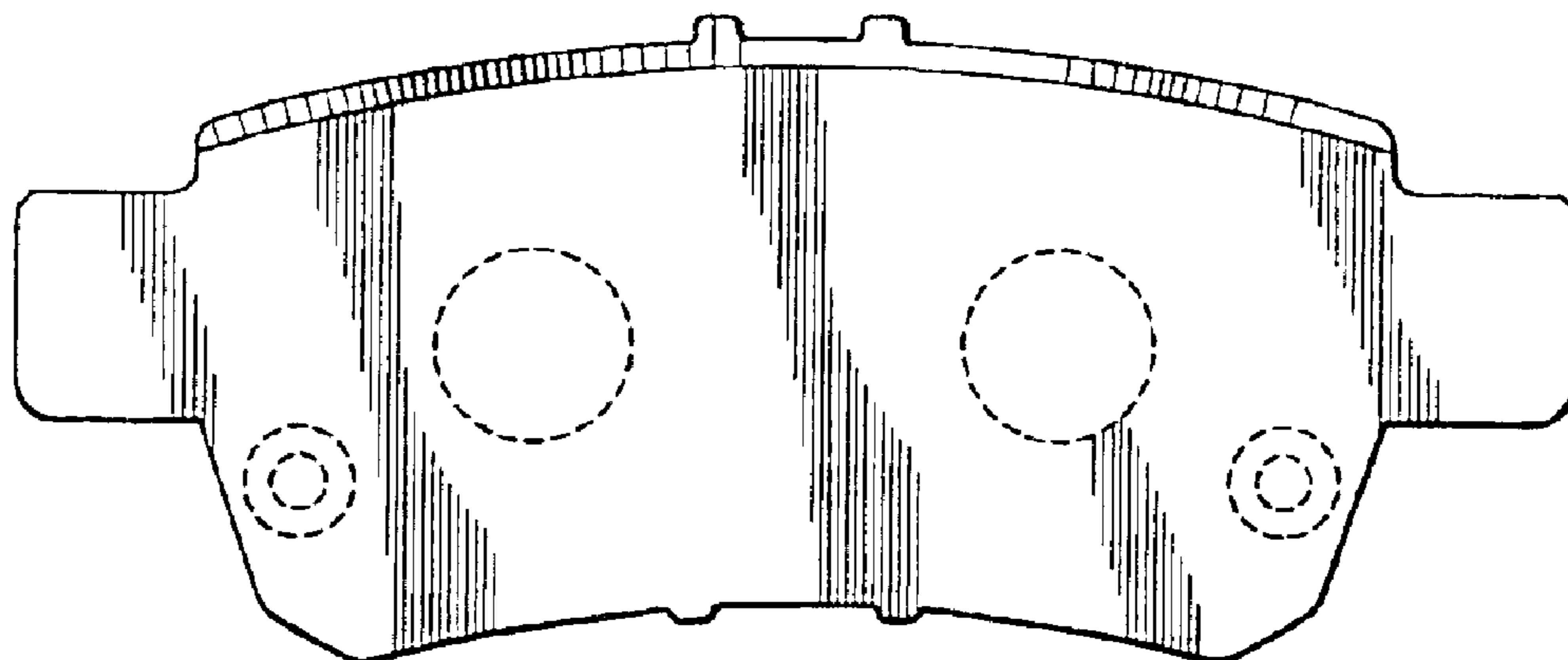

FIG.4

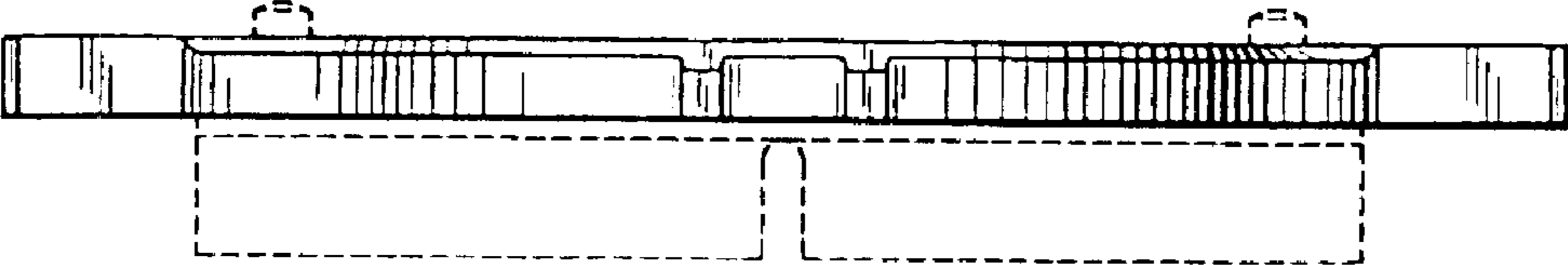

FIG.5

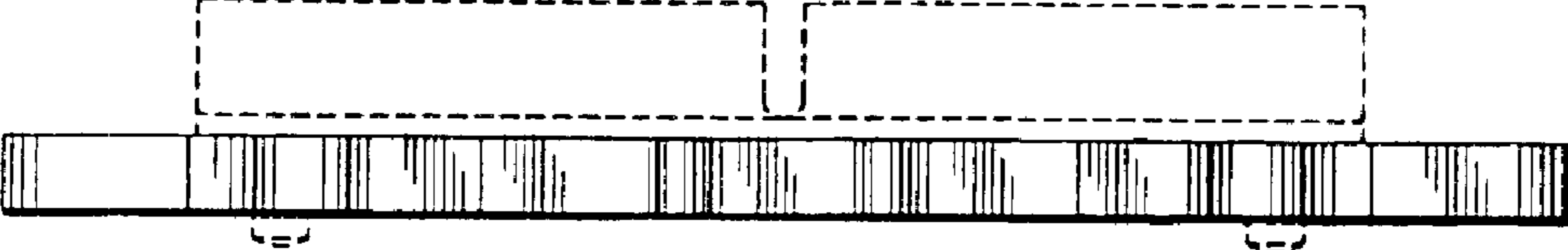

FIG.6

