

US00D506416S

(12) **United States Design Patent** (10) **Patent No.:** **US D506,416 S**
Boyer (45) **Date of Patent:** **** Jun. 21, 2005**

(54) **SURFACE CONFIGURATION OF A VEHICLE, TOY AND/OR OTHER REPLICAS**

(75) Inventor: **Boyke Boyer, Ismaning (DE)**

(73) Assignee: **Bayerische Motoren Werke Aktiengesellschaft, Munich (DE)**

(**) Term: **14 Years**

(21) Appl. No.: **29/204,040**

(22) Filed: **Apr. 23, 2004**

(30) **Foreign Application Priority Data**

Oct. 24, 2003 (DE) 403 06 906

(51) **LOC (8) Cl.** **12-08**

(52) **U.S. Cl.** **D12/91**

(58) **Field of Search** D12/90-92, 86;
D21/424, 433; 296/185

(56) **References Cited**

U.S. PATENT DOCUMENTS

D392,220 S	*	3/1998	Hausmann	D12/91
D436,059 S	*	1/2001	Goplen	D12/91
D464,914 S	*	10/2002	Warkuss et al.	D12/91
D476,923 S		7/2003	Boyer	D12/92
D489,648 S	*	5/2004	Gale et al.	D12/92
D496,306 S	*	9/2004	Chapman	D12/92
D499,357 S	*	12/2004	Velazco	D12/91

* cited by examiner

Primary Examiner—Melody N. Brown
(74) *Attorney, Agent, or Firm*—Crowell & Moring LLP

(57) **CLAIM**

The ornamental design for a surface configuration of a vehicle, toy and/or other replicas, as shown and described.

DESCRIPTION

This application is related to the following co-pending applications, of the inventor, filed on even date herewith: application Ser. No. 29/204,039, entitled “Surface Configuration of a Rear Fender for a Vehicle”; application Ser. No. 29/204,038, entitled “Surface Configuration of a Rear Door for a Vehicle”; and application Ser. No. 29/204,041, entitled “Surface Configuration of a Rear Bumper for a Vehicle”.

FIG. 1 is a left, front perspective view of a surface configuration of a vehicle, toy and/or other replicas according to my novel design, the right, front perspective view being mirror symmetrical;

FIG. 2 is a left, rear perspective view of the surface configuration of a vehicle, toy and/or other replicas according to my novel design, the right, rear perspective view being mirror symmetrical;

FIG. 3 is a left side view of the surface configuration of a vehicle, toy and/or other replicas according to my novel design;

FIG. 4 is a right side view of the surface configuration of a vehicle, toy and/or other replicas according to my novel design;

FIG. 5 is a front view of the surface configuration of a vehicle, toy and/or other replicas according to my novel design;

FIG. 6 is a rear view of the surface configuration of a vehicle, toy and/or other replicas according to my novel design; and,

FIG. 7 is a top view of the surface configuration of a vehicle, toy and/or other replicas according to my novel design.

The broken lines are for illustrative purposes only and form no part of the claimed design.

1 Claim, 5 Drawing Sheets

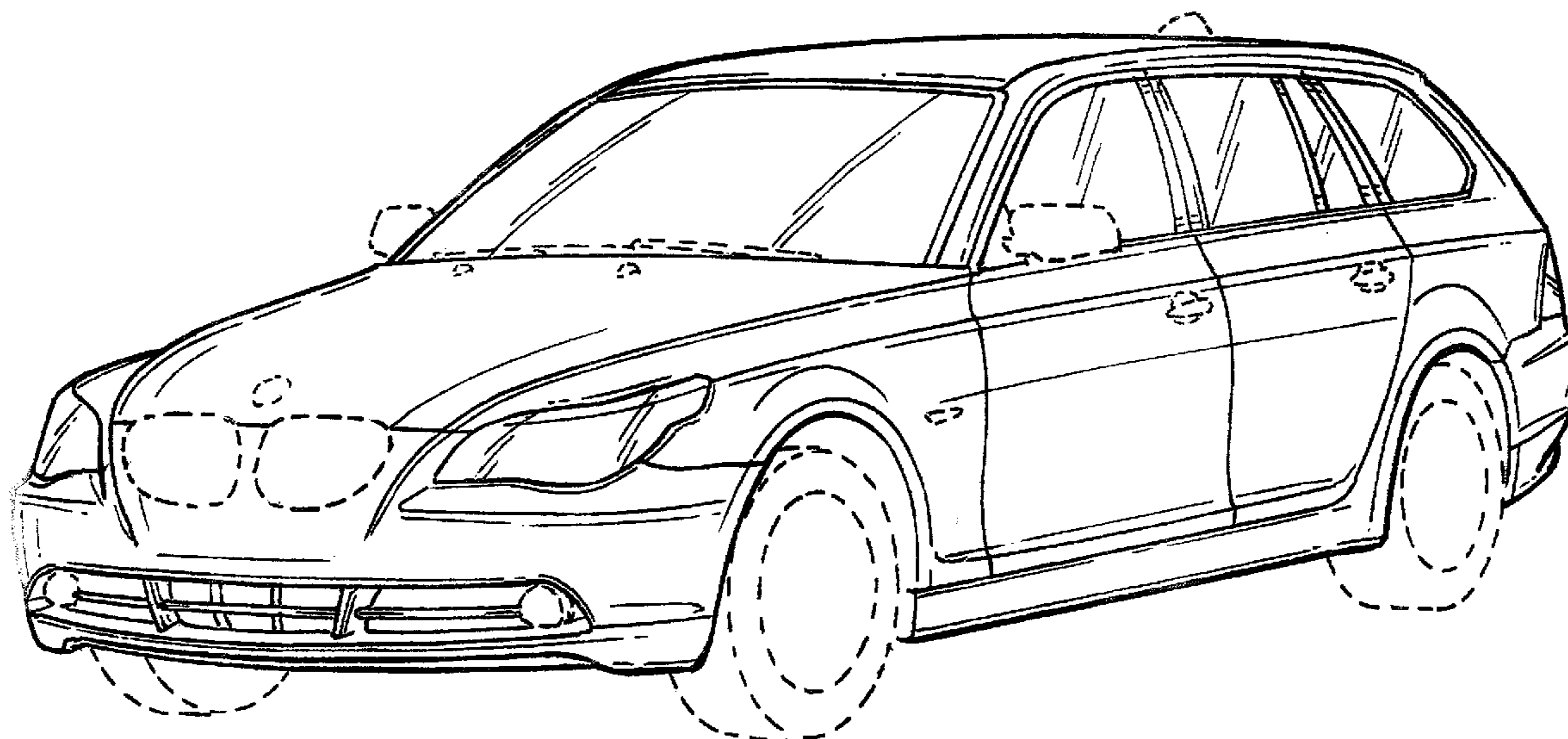

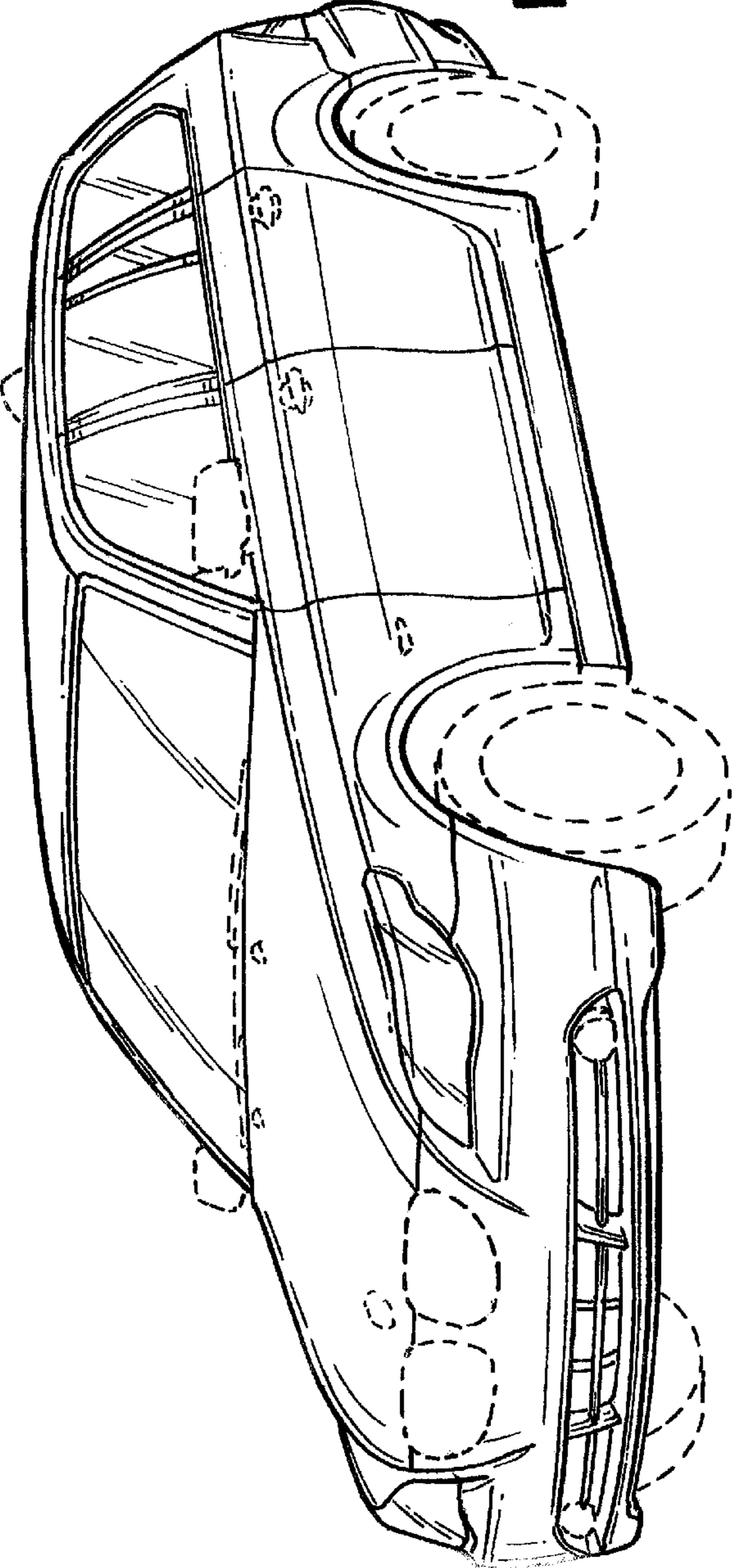

FIG. 1

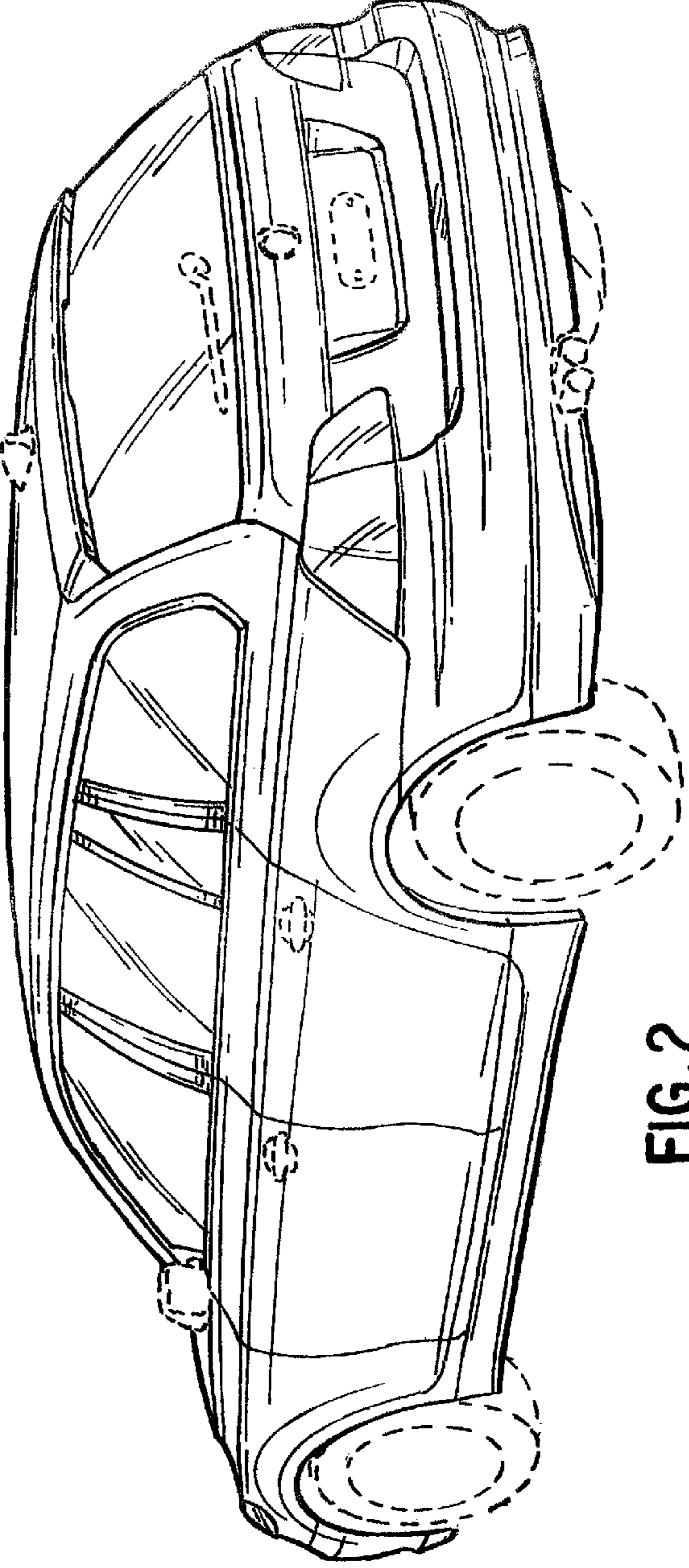

FIG. 2

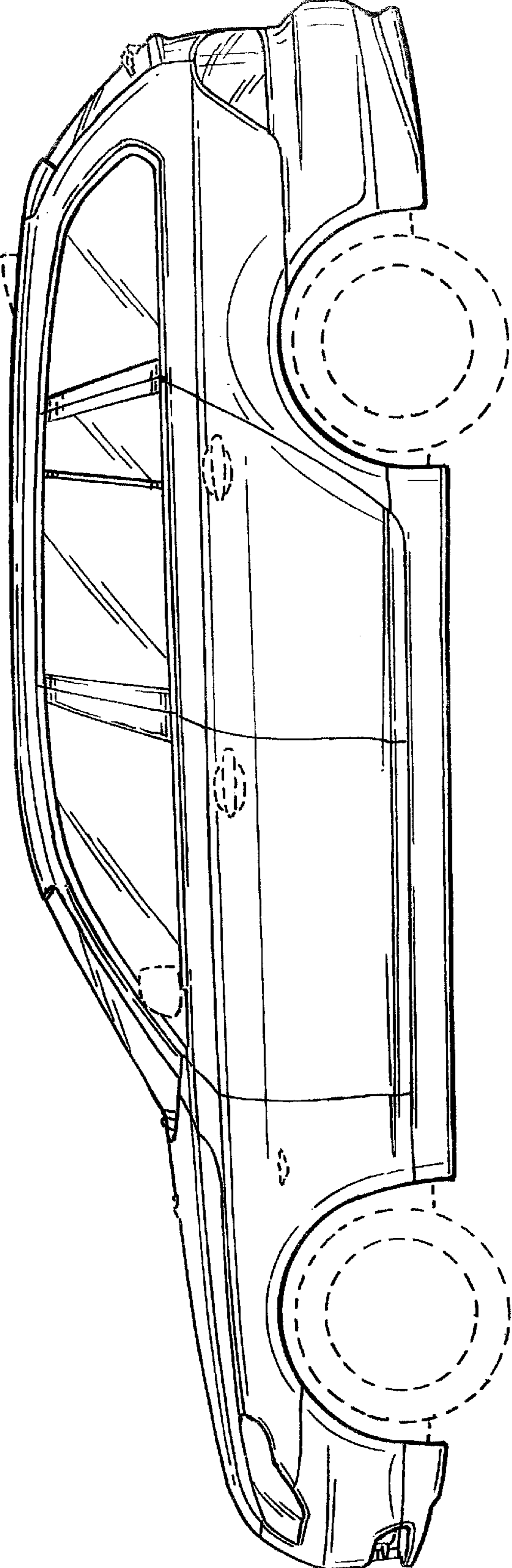

FIG. 3

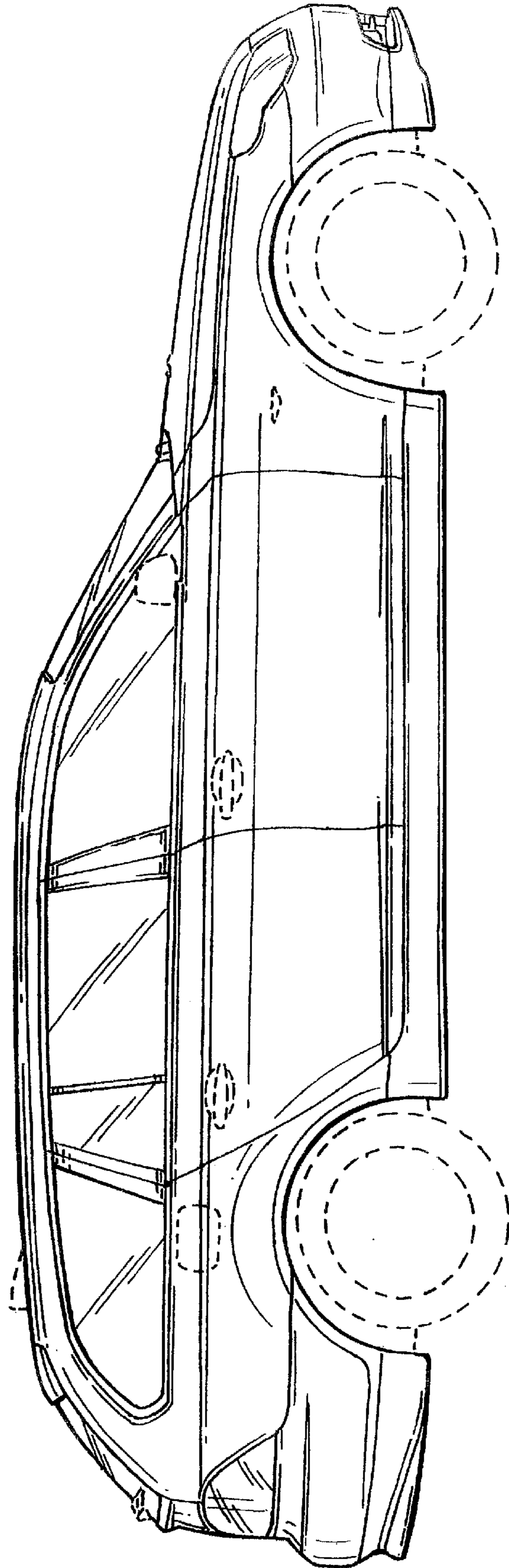

FIG. 4

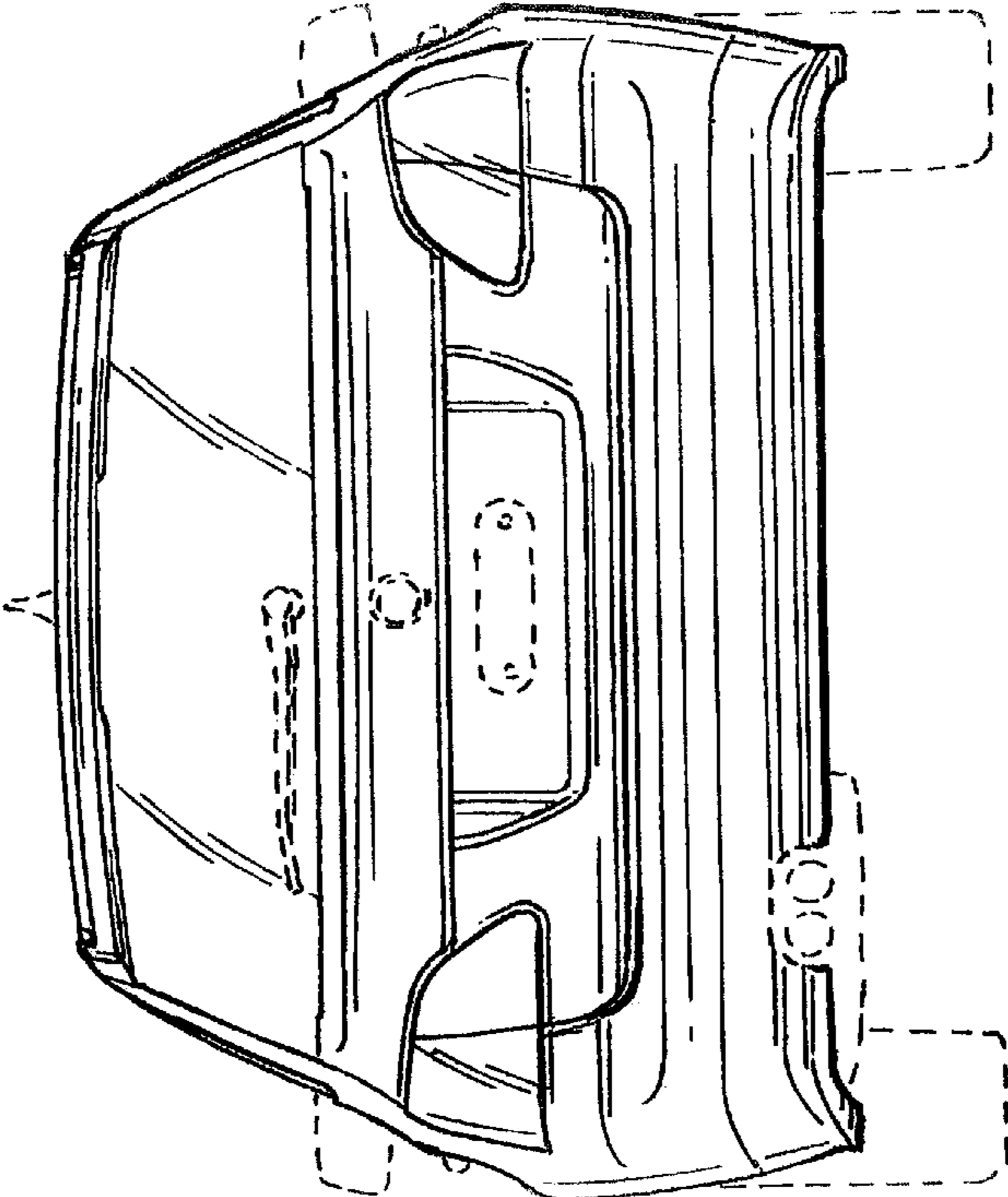

FIG. 6

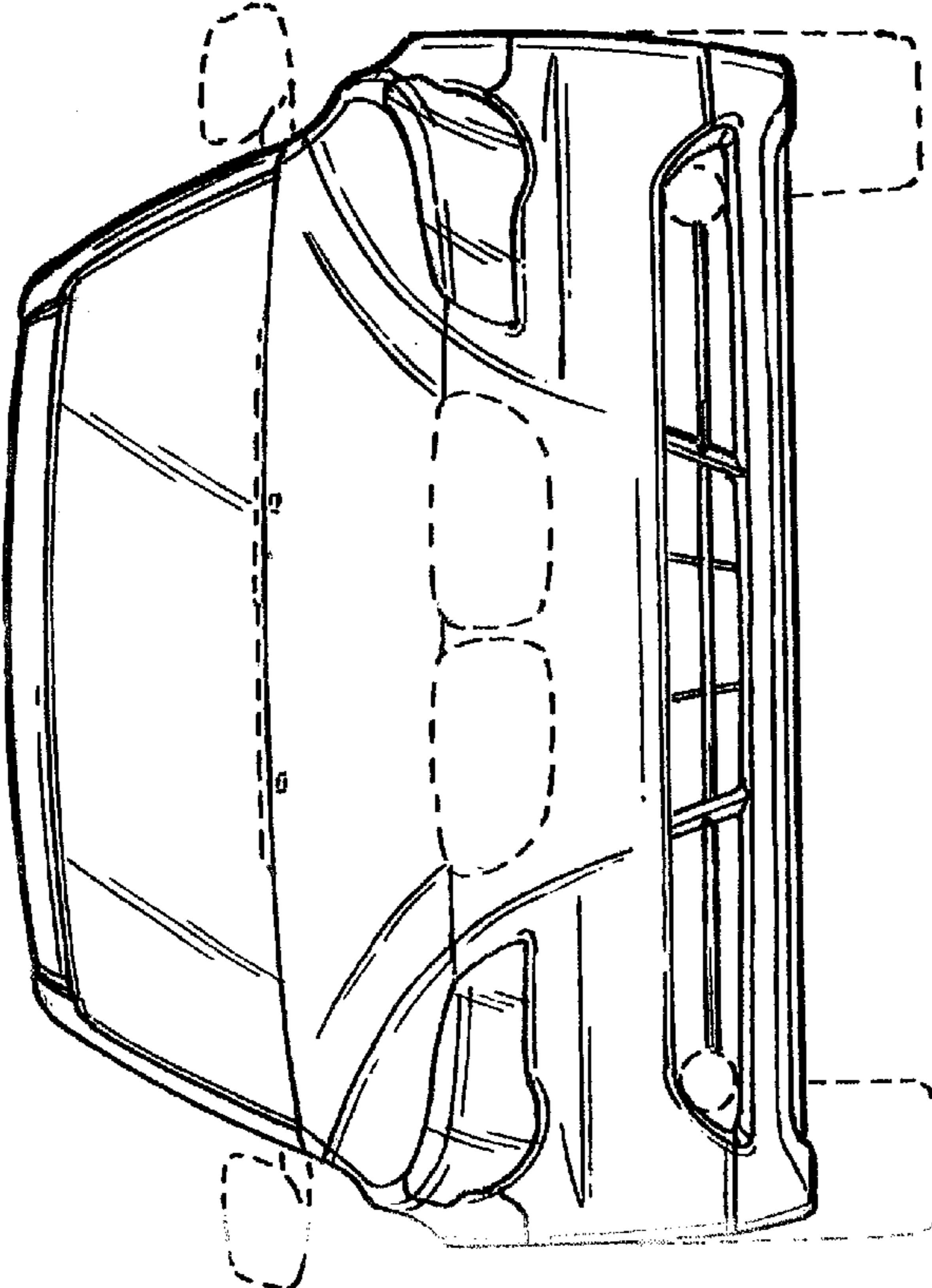

FIG. 5

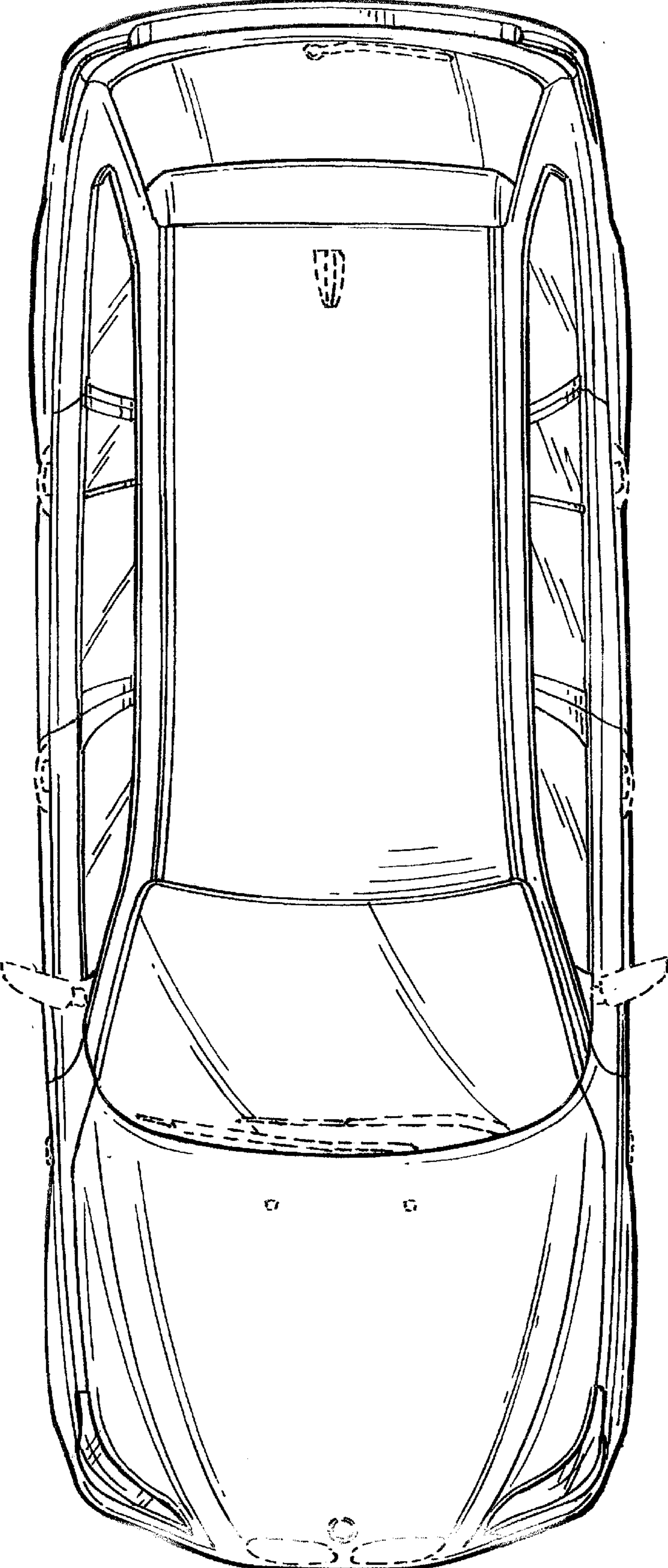

FIG. 7