

US00D506385S

(12) **United States Design Patent**
Brown

(10) **Patent No.:** **US D506,385 S**

(45) **Date of Patent:** **** Jun. 21, 2005**

(54) **SNAP CLAMP**

6,129,317 A 10/2000 Rodrigues et al.

(75) **Inventor:** **Larry D. Brown, San Diego, CA (US)**

* cited by examiner

(73) **Assignee:** **Securus, Inc., San Marcos, CA (US)**

Primary Examiner—Louis S. Zarfaz

Assistant Examiner—Gregory Andoll

(**) **Term:** **14 Years**

(74) *Attorney, Agent, or Firm*—Stetina Brunda Garred & Brucker

(21) **Appl. No.:** **29/179,017**

(57) **CLAIM**

(22) **Filed:** **Apr. 3, 2003**

The ornamental design for a snap clamp, as shown and described.

(51) **LOC (8) Cl.** **08-08**

(52) **U.S. Cl.** **D8/396; D8/394**

(58) **Field of Search** D8/395, 396, 356;
24/336, 339; 248/74.1, 74.2, 68.1, 229.26;
403/391, 396, 397, 400; D26/138

DESCRIPTION

(56) **References Cited**

U.S. PATENT DOCUMENTS

1,129,553 A	2/1915	Cope	
2,354,919 A	8/1944	Lockwood	
3,128,073 A	4/1964	Berlyn	
3,188,030 A	6/1965	Fischer	
D212,505 S	* 10/1968	Guerrero	D8/396
3,944,175 A	3/1976	Kearney	
4,051,035 A	9/1977	Boschen et al.	
D269,155 S	* 5/1983	Rose	D8/356
4,395,009 A	7/1983	Bormke	
4,555,589 A	11/1985	Osada	
4,562,982 A	1/1986	McSherry et al.	
4,655,023 A	4/1987	Yung	
4,679,754 A	7/1987	Richards	
4,766,651 A	8/1988	Kobayashi et al.	
D299,213 S	* 1/1989	Puntillo	D8/395
4,899,963 A	2/1990	Murphy	
4,905,942 A	3/1990	Moretti	
4,993,669 A	2/1991	Dyer	
5,002,244 A	3/1991	Holbury et al.	
5,131,613 A	7/1992	Kamiya et al.	
5,149,026 A	9/1992	Allen	
5,303,887 A	4/1994	Hasty et al.	
5,367,127 A	11/1994	Dormon	
5,598,995 A	2/1997	Meuth et al.	
5,655,738 A	8/1997	Ragsdale et al.	
5,876,000 A	3/1999	Ismert	
D408,273 S	* 4/1999	Senninger	D8/356
6,126,122 A	10/2000	Ismert	

FIG. 1 is a top perspective view of a snap clamp holding a pipe and being mounted to a bracket by a bolt and washer with the bracket, pipe, bolt and washer not comprising a portion of the invention and being shown in broken lines to show one context for the invention;

FIG. 2 is a top left perspective view of the front of the snap clamp of FIG. 1 and having an elongated slot in a mounting flange of the snap clamp;

FIG. 3 is a top left perspective view of the back of the snap clamp of FIG. 2;

FIG. 4 is front plan view of the snap clamp of FIG. 2;

FIG. 5 is back plan view of the snap clamp of FIG. 2;

FIG. 6 is left plan view of the snap clamp of FIG. 2;

FIG. 7 is right plan view of the snap clamp of FIG. 2;

FIG. 8 is bottom plan view of the snap clamp of FIG. 2;

FIG. 9 is top plan view of the snap clamp of FIG. 2;

FIG. 10 is a top left perspective view of the front of the snap clamp of FIG. 1 and having a round hole in the mounting flange;

FIG. 11 is a top left perspective view of the back of the snap clamp of FIG. 10;

FIG. 12 is front plan view of the snap clamp of FIG. 10;

FIG. 13 is back plan view of the snap clamp of FIG. 10;

FIG. 14 is left plan view of the snap clamp of FIG. 10;

FIG. 15 is right plan view of the snap clamp of FIG. 10;

FIG. 16 is bottom plan view of the snap clamp of FIG. 10;

and,

FIG. 17 is top plan view of the snap clamp of FIG. 10.

1 Claim, 3 Drawing Sheets

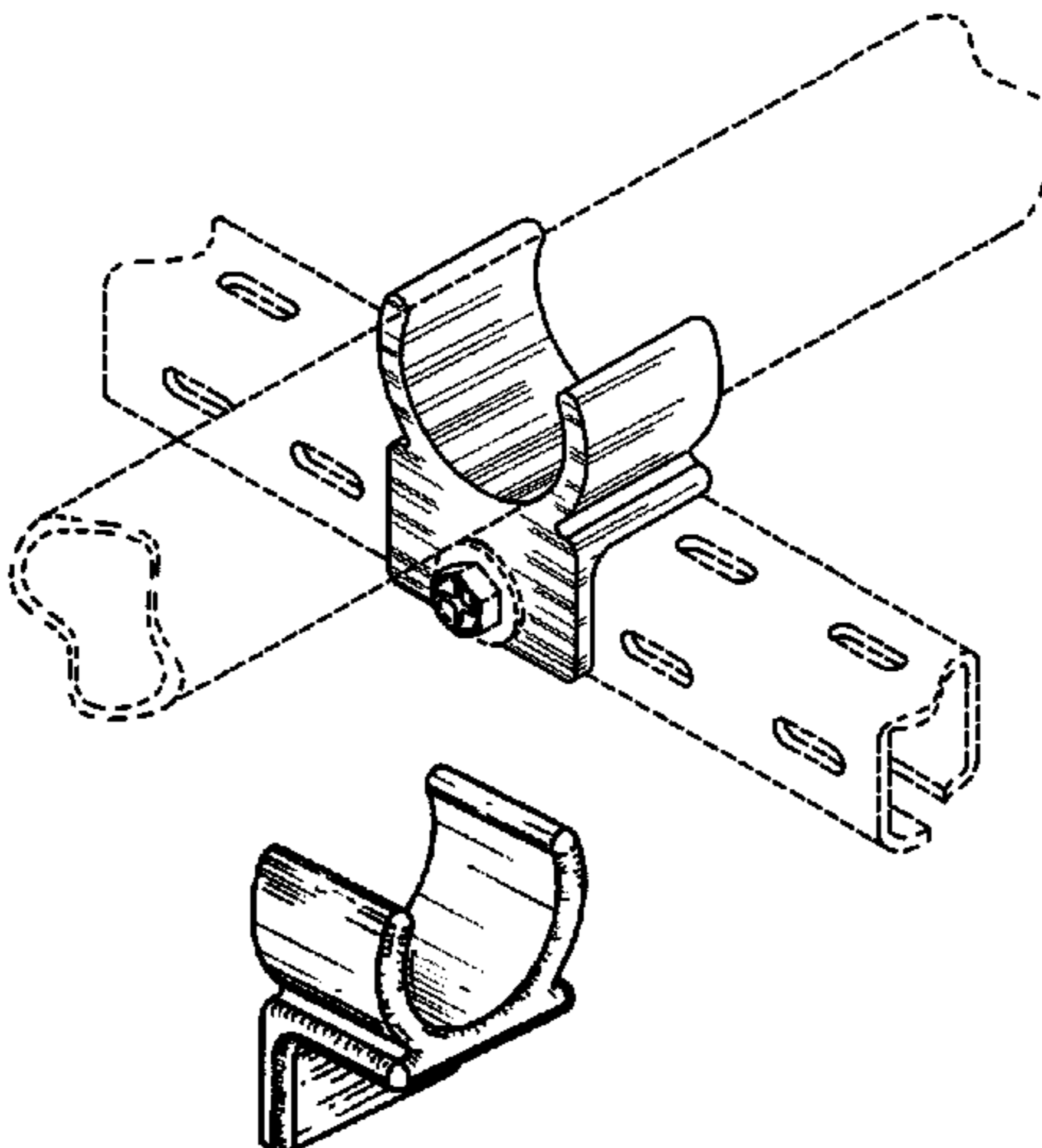

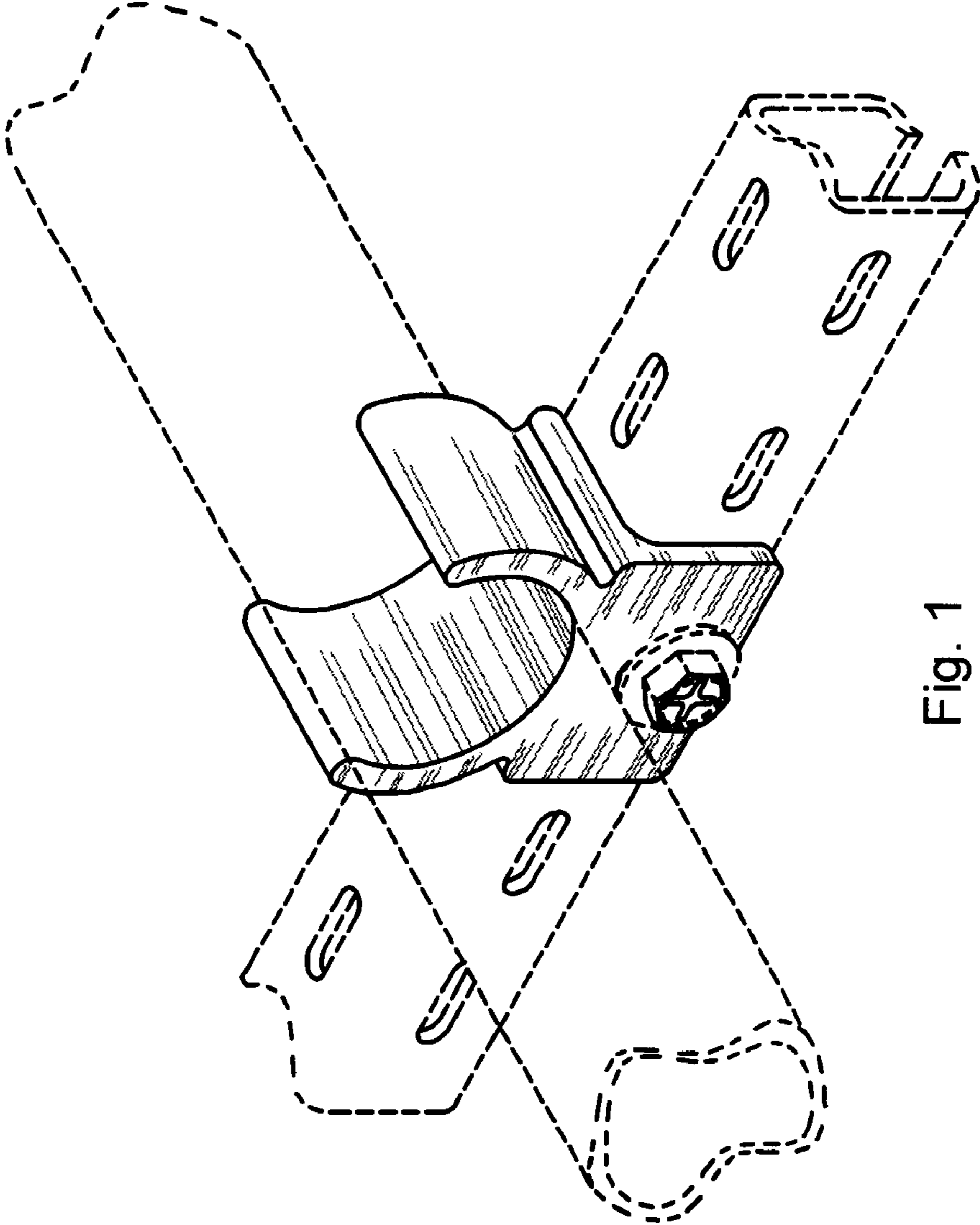

Fig. 1

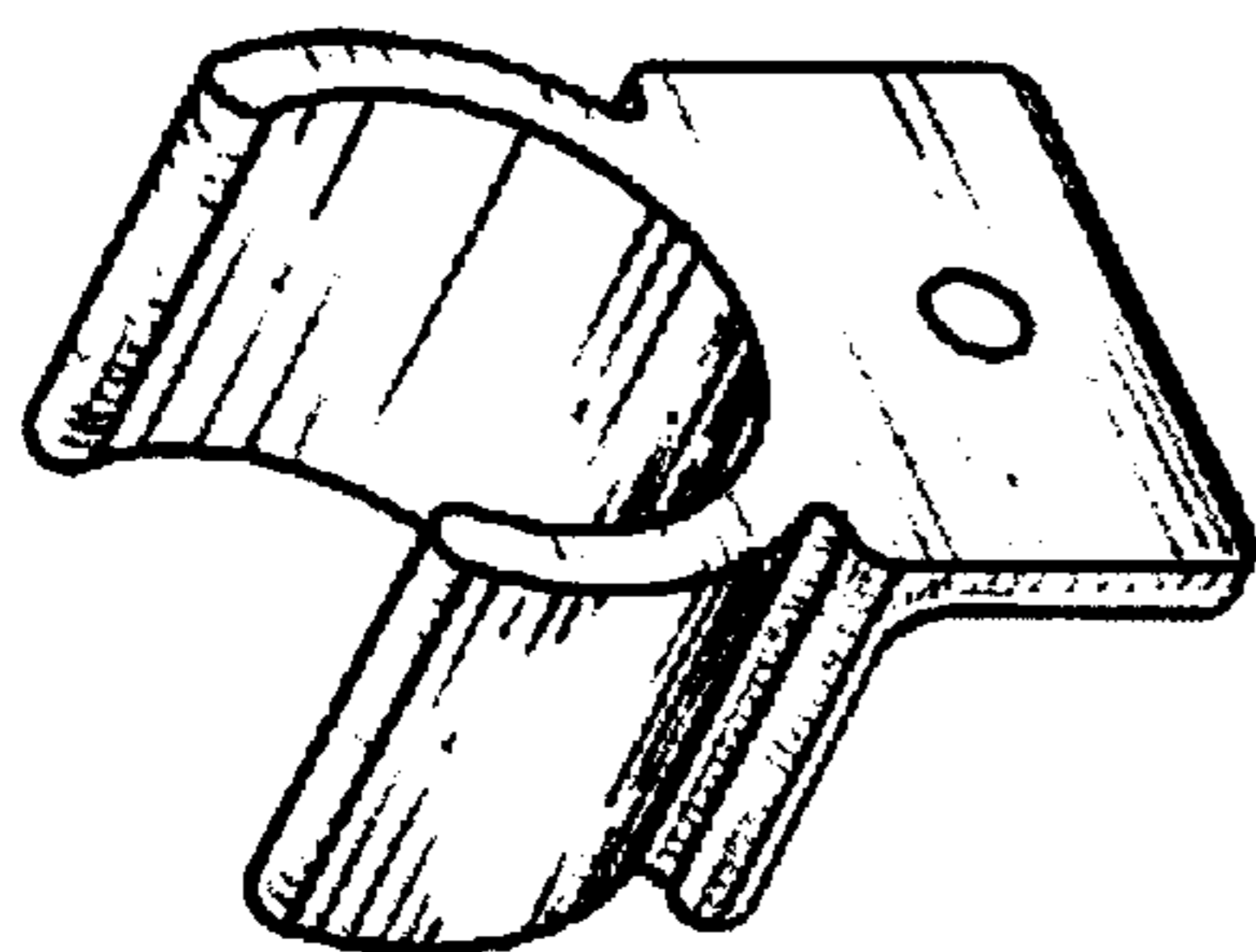

Fig. 2

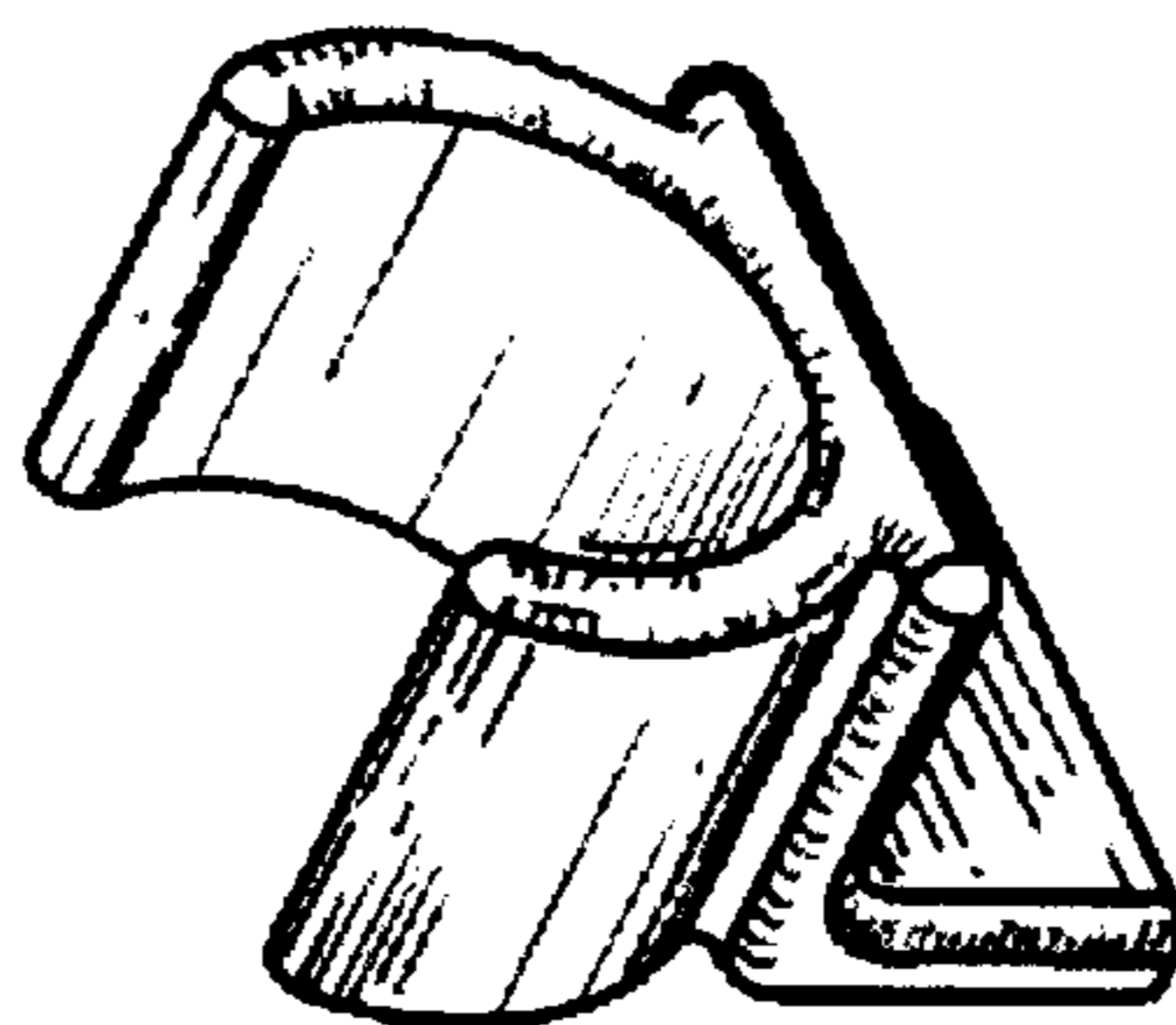

Fig. 3

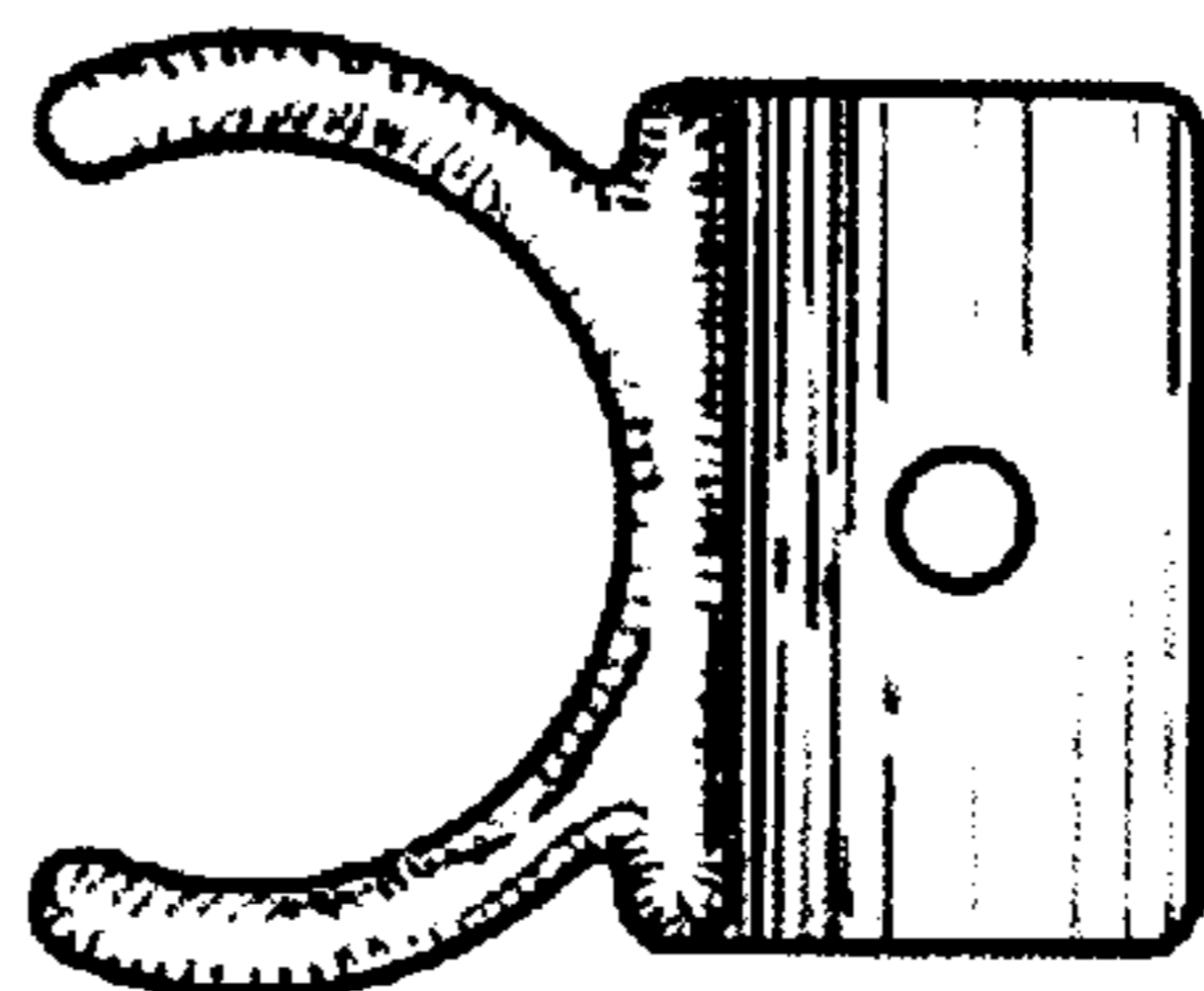

Fig. 5

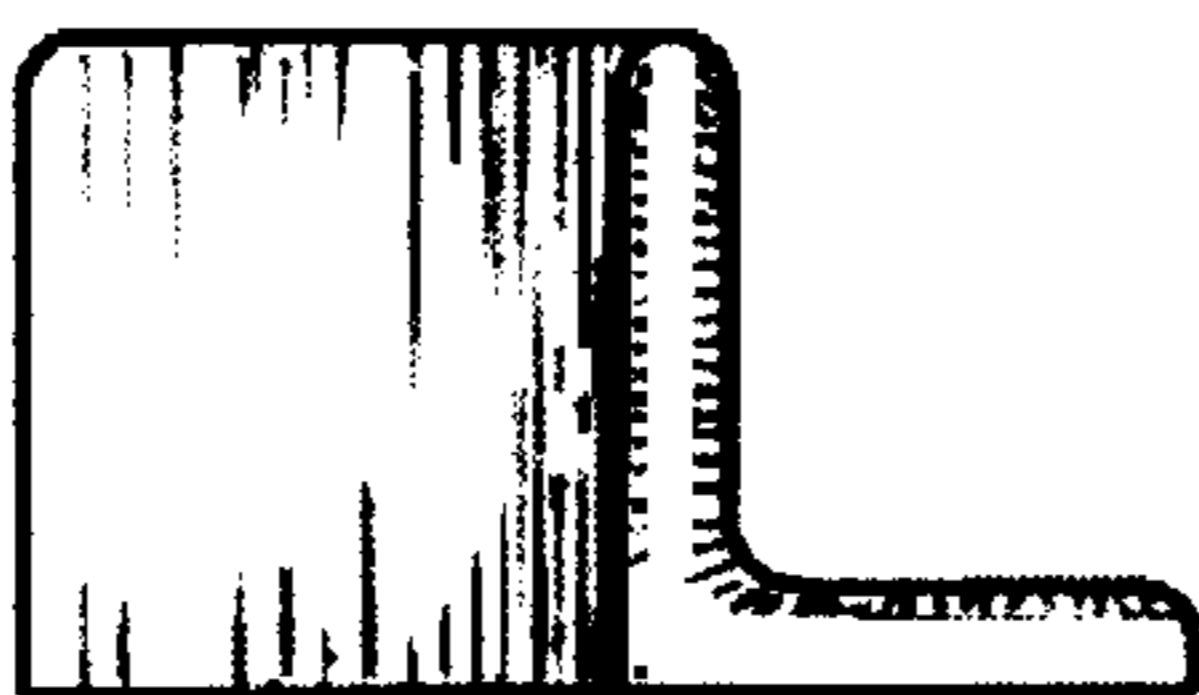

Fig. 7

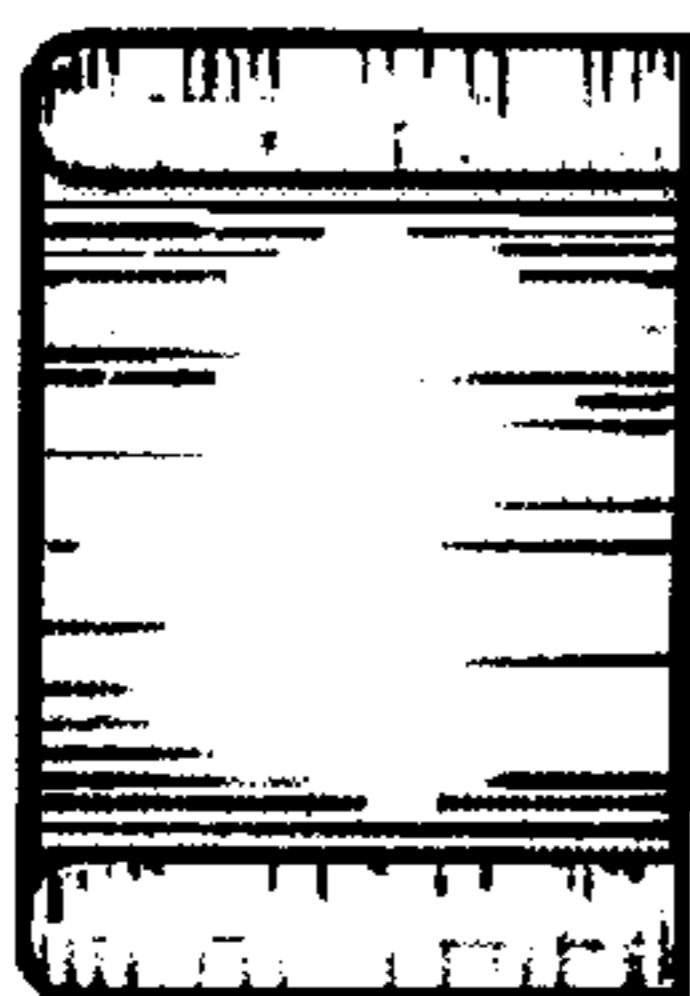

Fig. 9

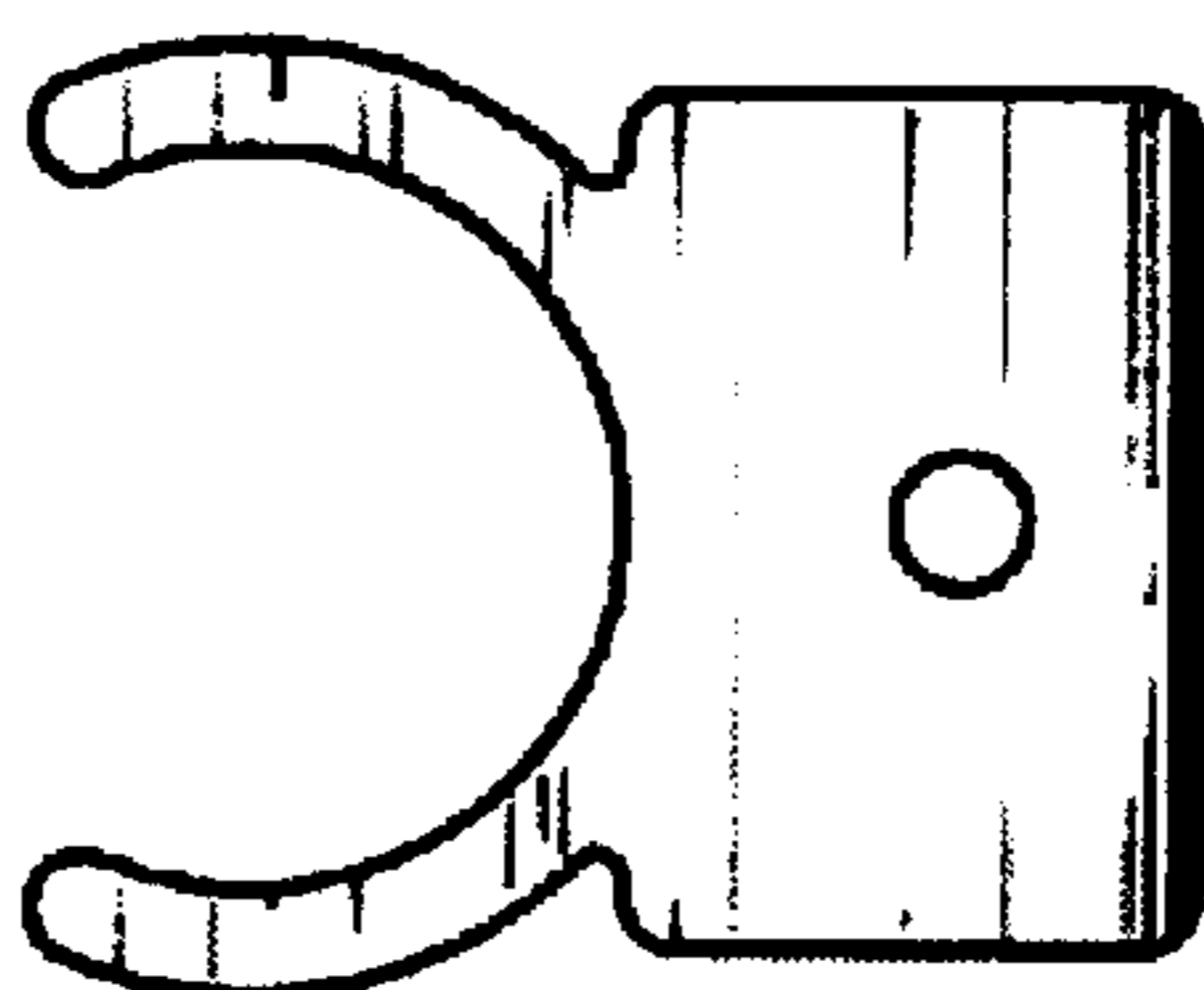

Fig. 4

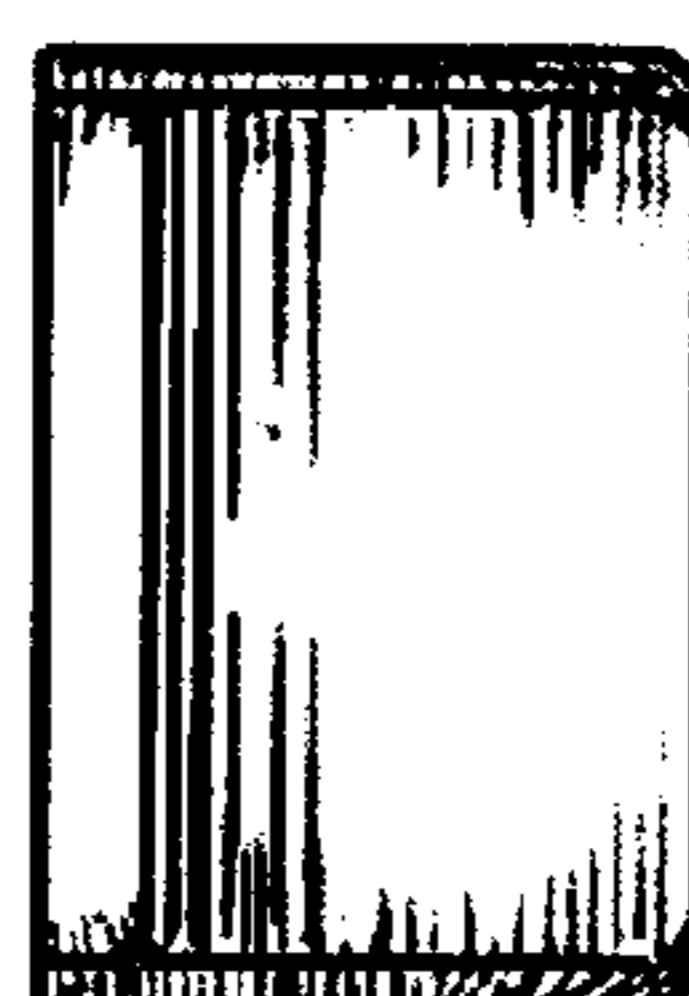

Fig. 8

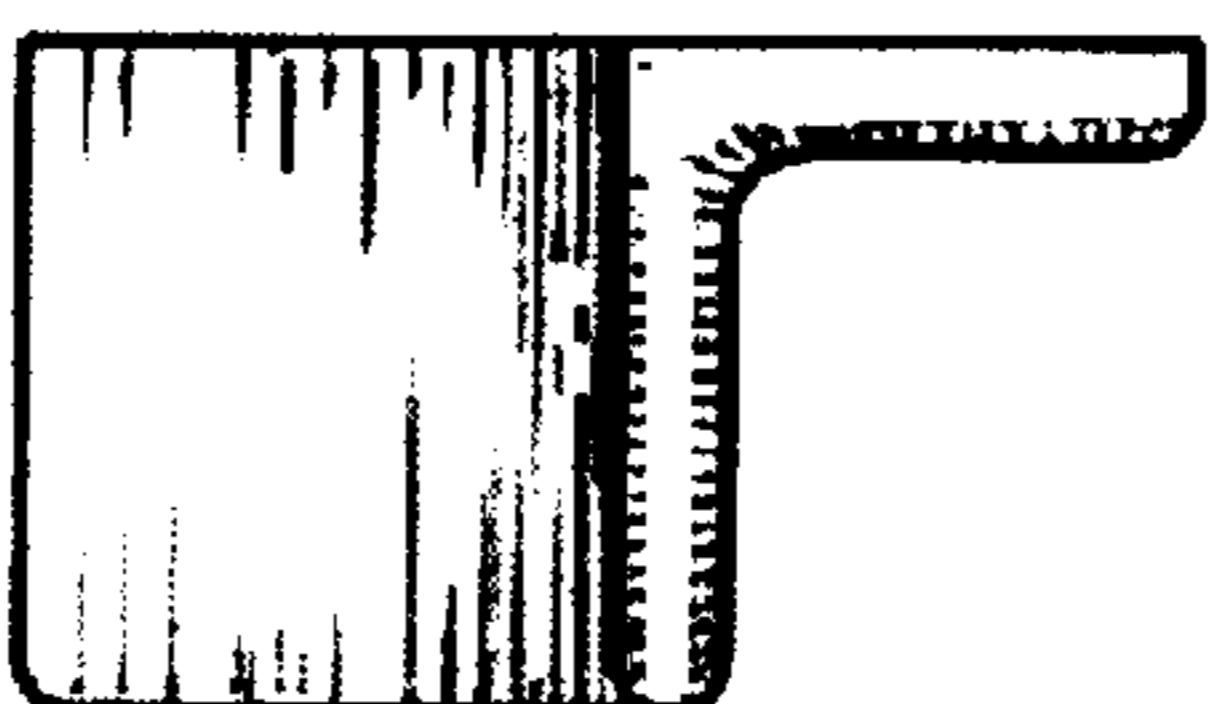

Fig. 6

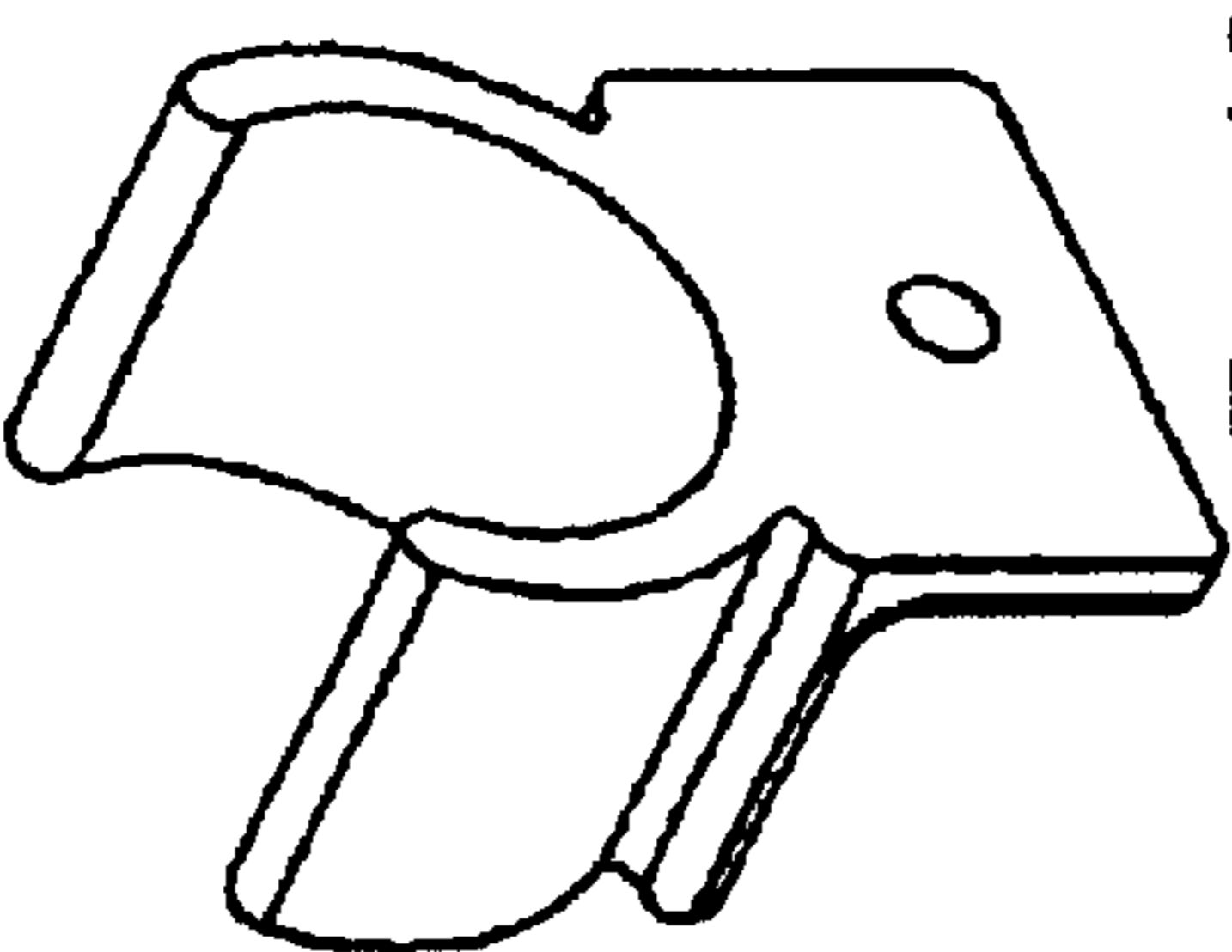

Fig. 10

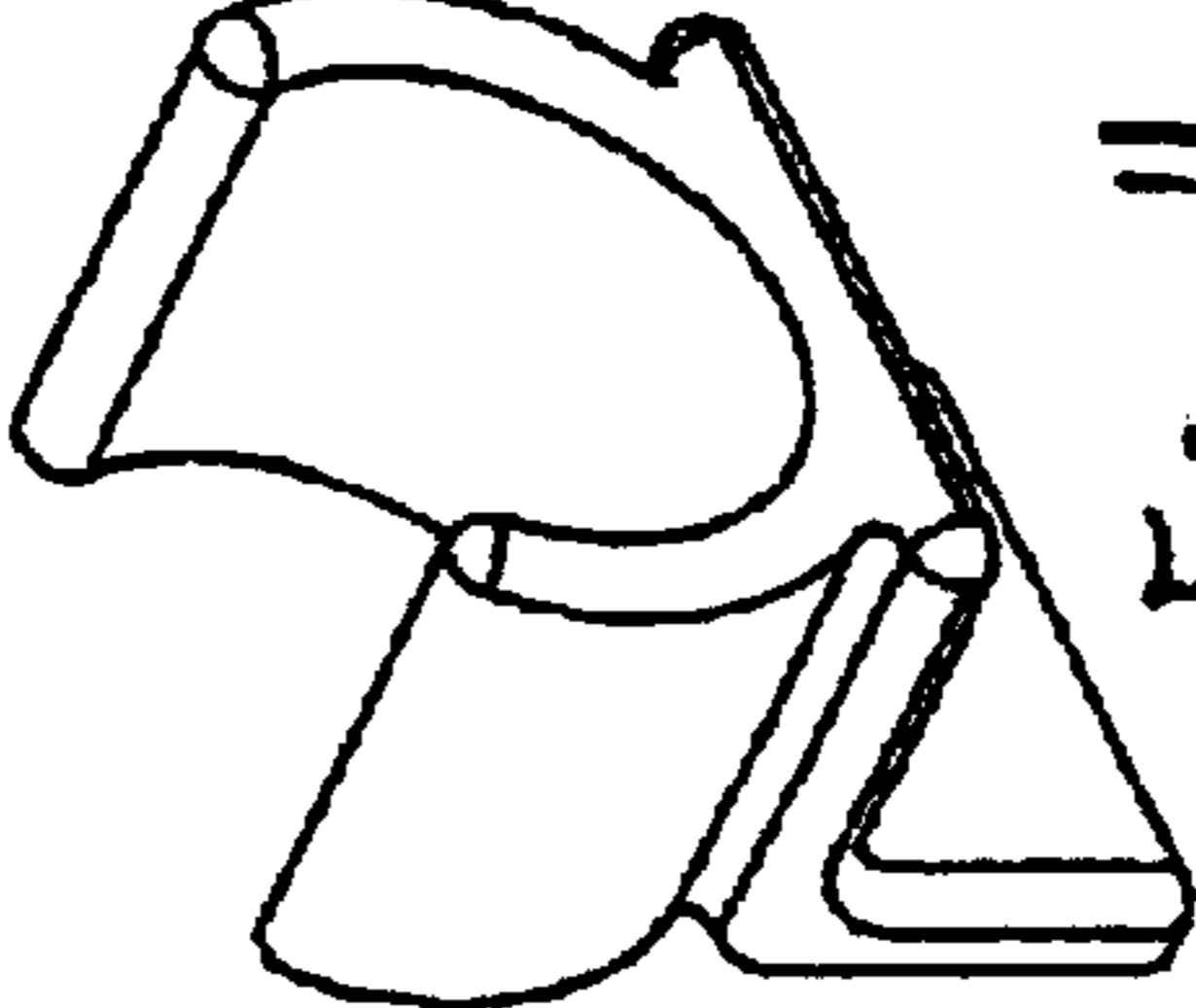

Fig. 11

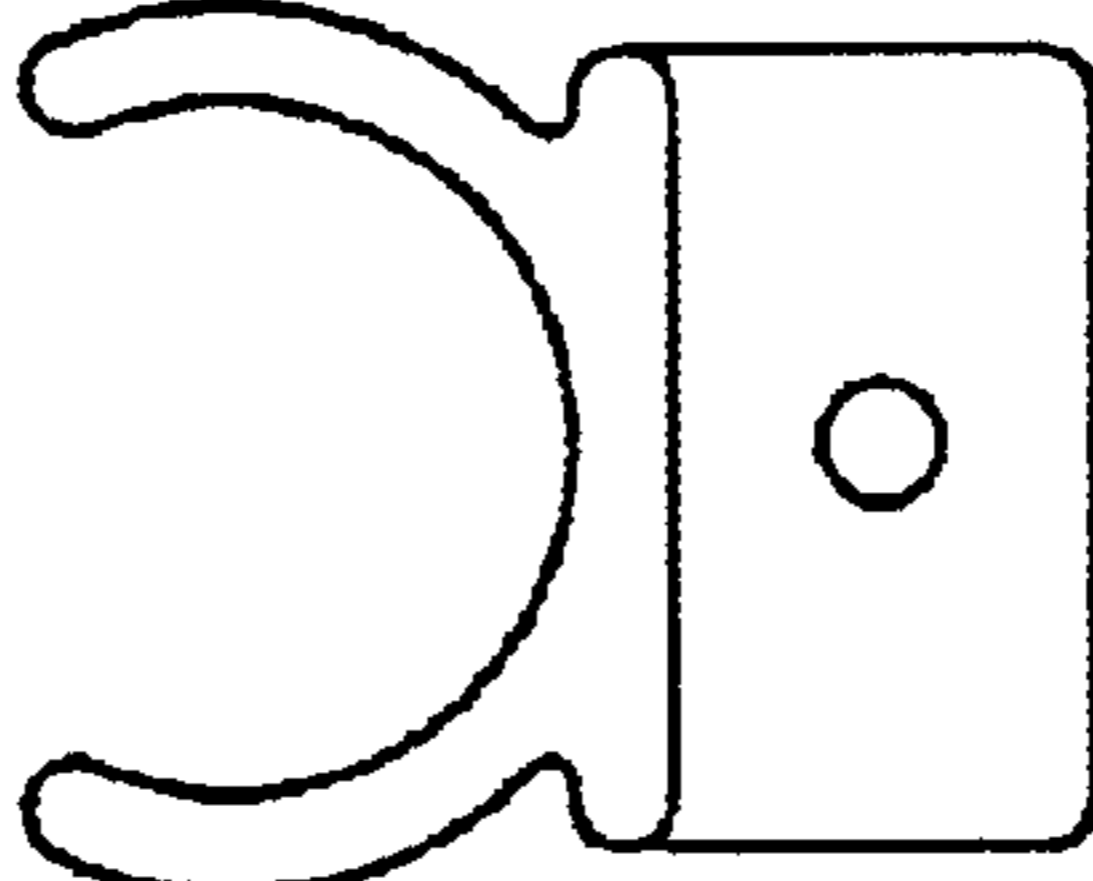

Fig. 13

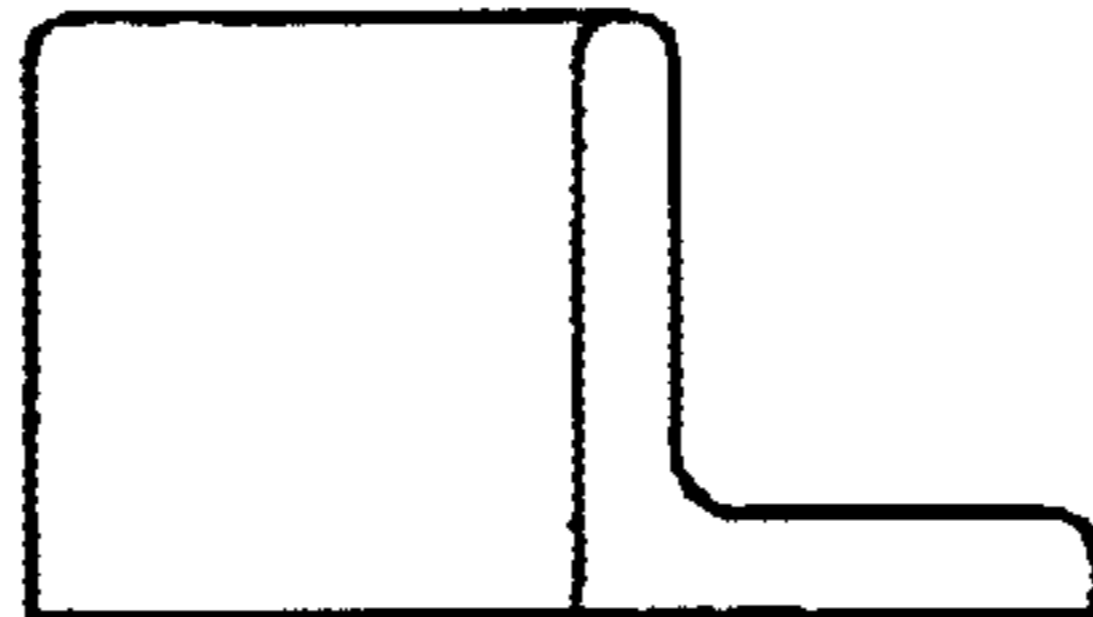

Fig. 15

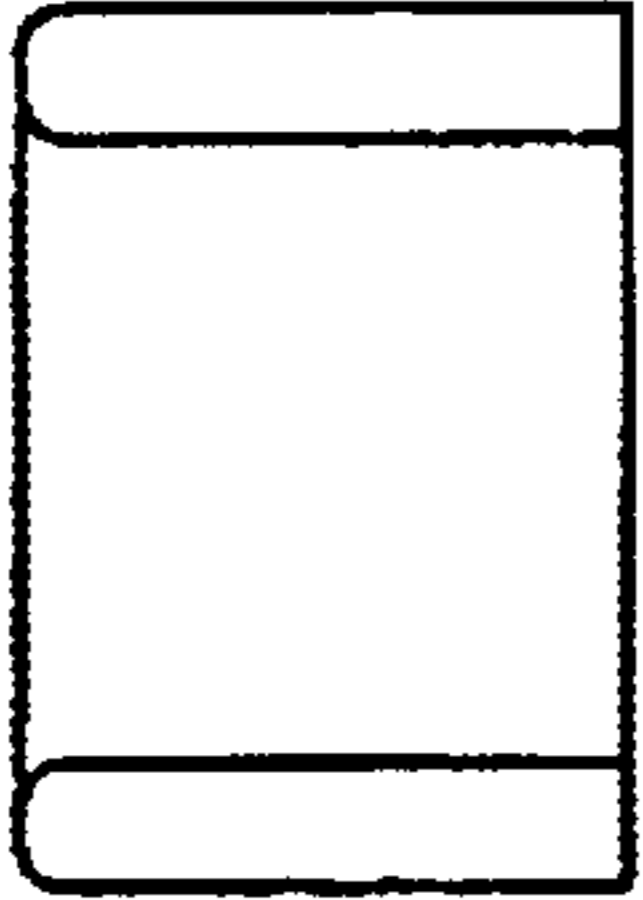

Fig. 17

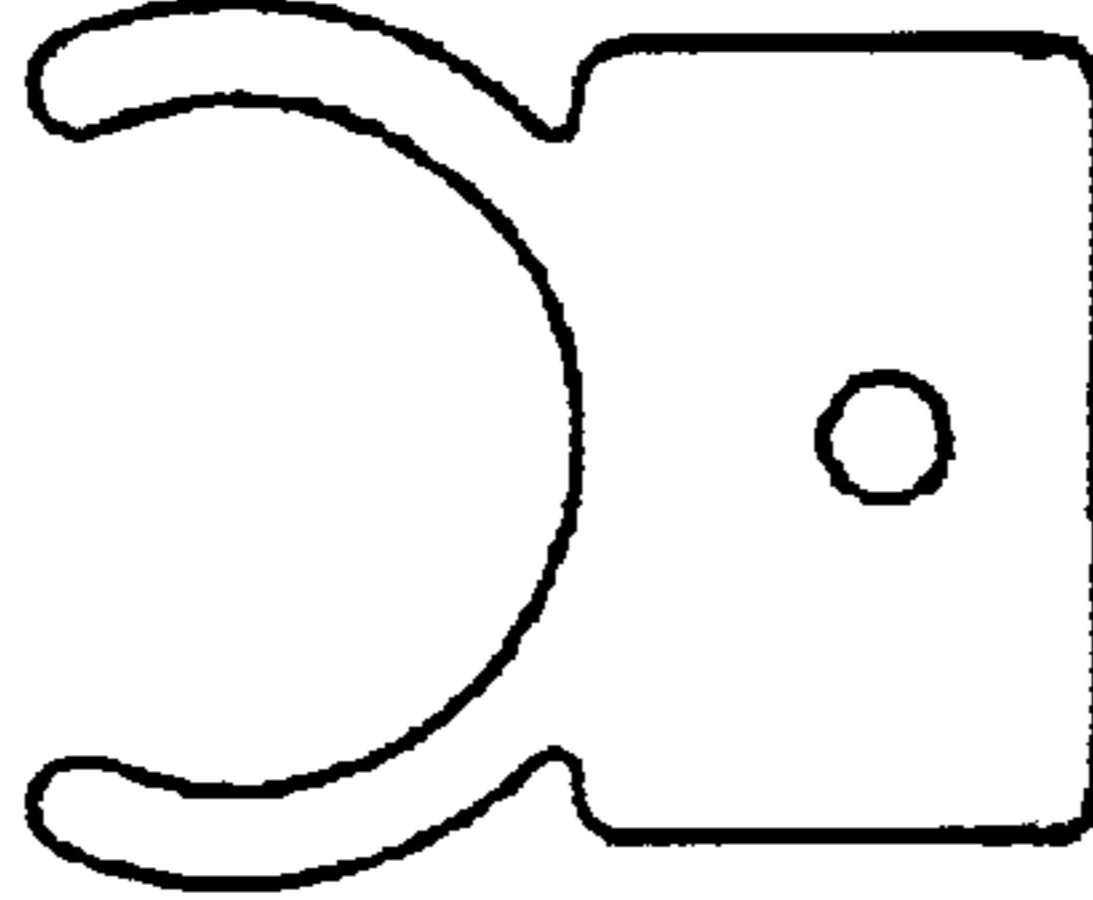

Fig. 12

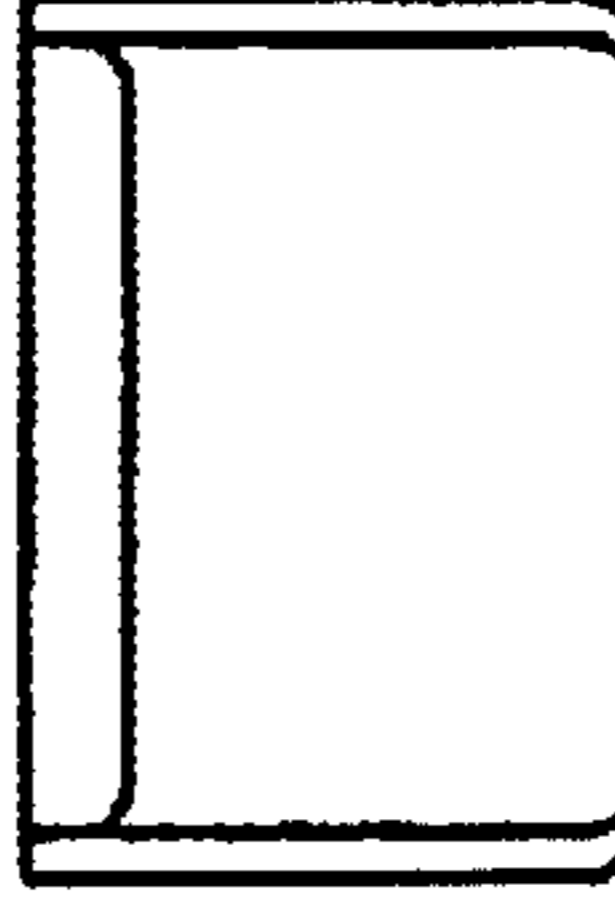

Fig. 16

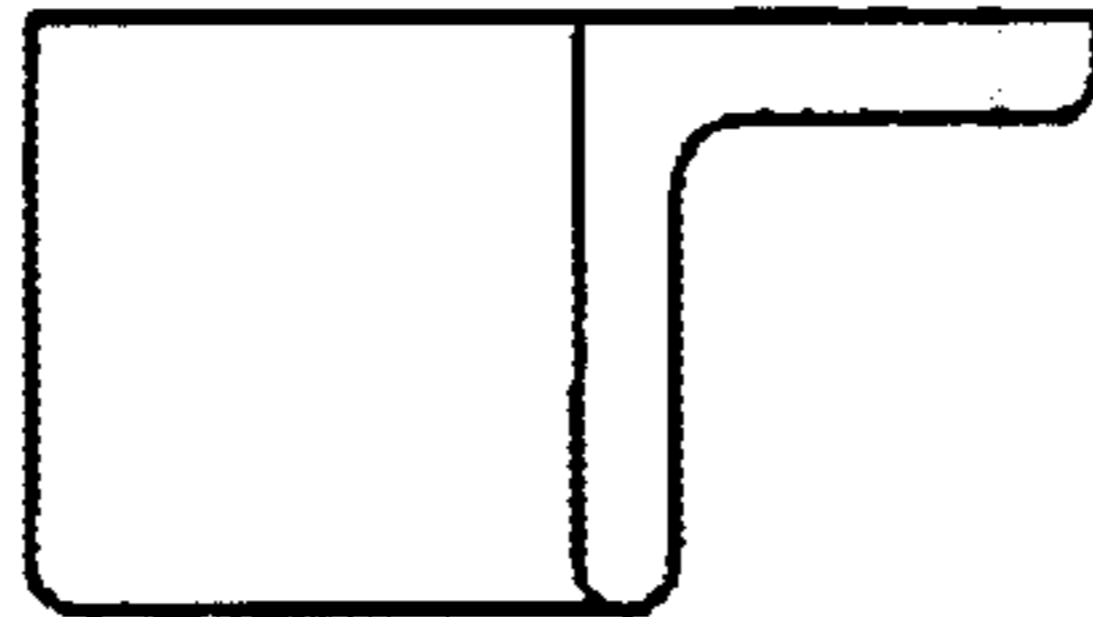

Fig. 14