

US00D506169S

(12) **United States Design Patent** (10) **Patent No.:** **US D506,169 S**
Pfeiffer et al. (45) **Date of Patent:** **** Jun. 14, 2005**

(54) **SURFACE CONFIGURATION OF A SIDE MIRROR FOR A VEHICLE**

(75) Inventors: **Peter Pfeiffer**, Boeblingen (DE);
Hans-Dieter Futschik, Gechingen (DE)

(73) Assignee: **DaimlerChrysler AG**, Stuttgart (DE)

(**) Term: **14 Years**

(21) Appl. No.: **29/201,387**

(22) Filed: **Mar. 16, 2004**

(30) **Foreign Application Priority Data**

Oct. 15, 2003 (DE) 403 06 633

(51) **LOC (8) Cl.** **12-16**

(52) **U.S. Cl.** **D12/187**

(58) **Field of Search** D12/187-189;
359/830-856, 864-881; 248/475.1, 476

(56) **References Cited**

U.S. PATENT DOCUMENTS

D410,421 S	*	6/1999	Pfeiffer	D12/187
D428,840 S	*	8/2000	Weidhase	D12/187
D445,386 S	*	7/2001	Sacco et al.	D12/187
D463,342 S	*	9/2002	Sinkwitz	D12/187
D464,922 S	*	10/2002	Kuo	D12/187
D484,837 S	*	1/2004	Liu	D12/187
D493,755 S	*	8/2004	Kneefel et al.	D12/187
D496,616 S	*	9/2004	Hoelzel et al.	D12/187

* cited by examiner

Primary Examiner—Melody N. Brown

(74) *Attorney, Agent, or Firm*—Crowell & Moring LLP

(57) **CLAIM**

The ornamental design for a surface configuration of a side mirror for a vehicle, as shown and described.

DESCRIPTION

FIG. 1 is a rear perspective view of a first embodiment of a surface configuration of a side mirror for a vehicle according to our novel design;

FIG. 2 is a front perspective view of the first embodiment of the surface configuration of a side mirror for a vehicle according to our novel design;

FIG. 3 is a rear, elevated perspective view of the first embodiment of the surface configuration of a side mirror for a vehicle according to our novel design;

FIG. 4 is a front view of the first embodiment of the surface configuration of a side mirror for a vehicle according to our novel design;

FIG. 5 is a top view of the first embodiment of the surface configuration of a side mirror for a vehicle according to our novel design;

FIG. 6 is a side view of the first embodiment of the surface configuration of a side mirror for a vehicle according to our novel design;

FIG. 7 is a bottom view of the first embodiment of the surface configuration of a side mirror for a vehicle according to our novel design;

FIG. 8 is a rear perspective view of a second embodiment of the surface configuration of a side mirror for a vehicle according to our novel design;

FIG. 9 is a front perspective view of the second embodiment of the surface configuration of a side mirror for a vehicle according to our novel design;

FIG. 10 is a rear, elevated perspective view of the second embodiment of the surface configuration of a side mirror for a vehicle according to our novel design;

FIG. 11 is a front view of the second embodiment of the surface configuration of a side mirror for a vehicle according to our novel design;

FIG. 12 is a top view of the second embodiment of the surface configuration of a side mirror for a vehicle according to our novel design;

FIG. 13 is a side view of the second embodiment of the surface configuration of a side mirror for a vehicle according to our novel design; and,

FIG. 14 is a bottom view of the second embodiment of the surface configuration of a side mirror for a vehicle according to our novel design.

The broken lines are for illustrative purposes only and form no part of the claimed design.

1 Claim, 8 Drawing Sheets

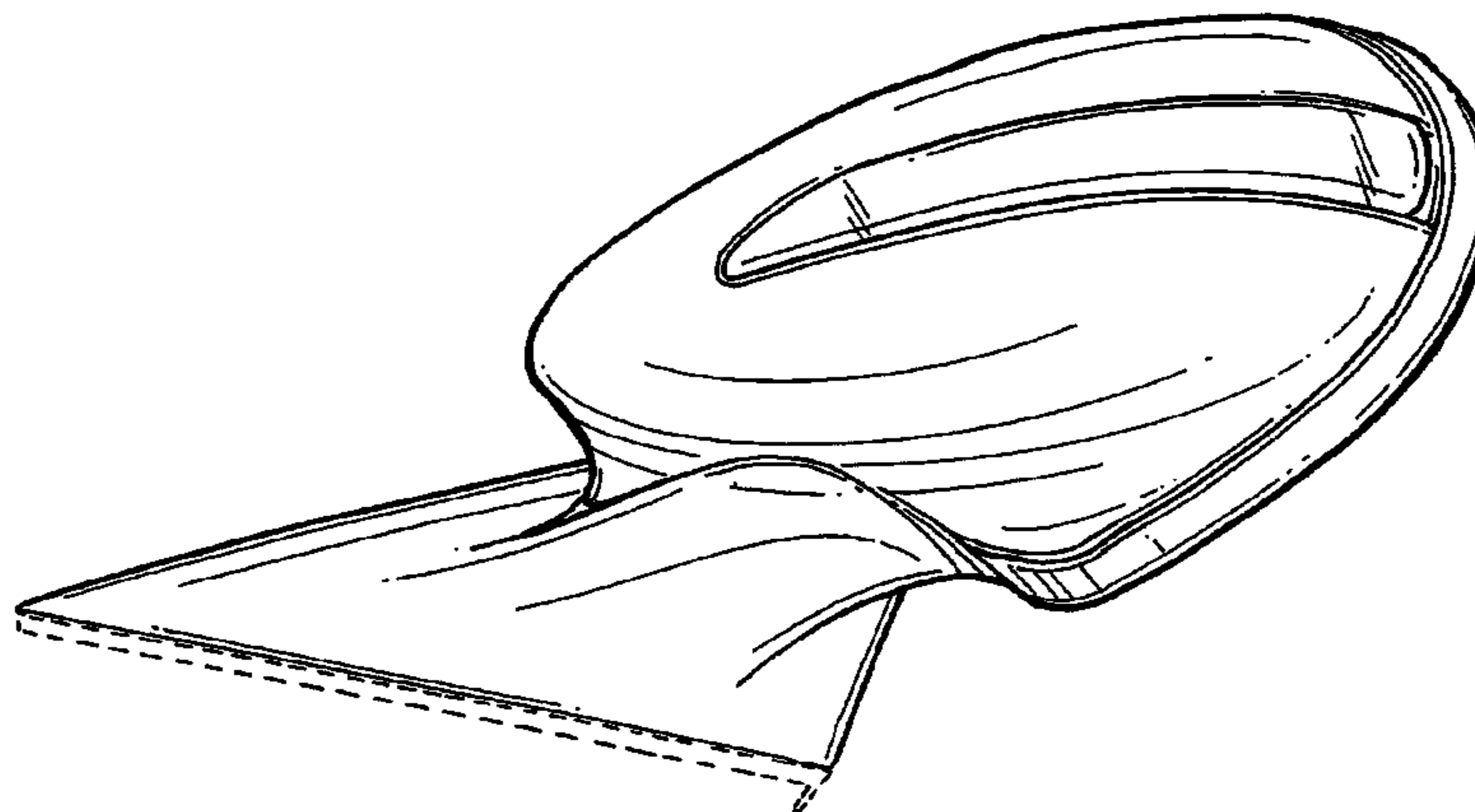

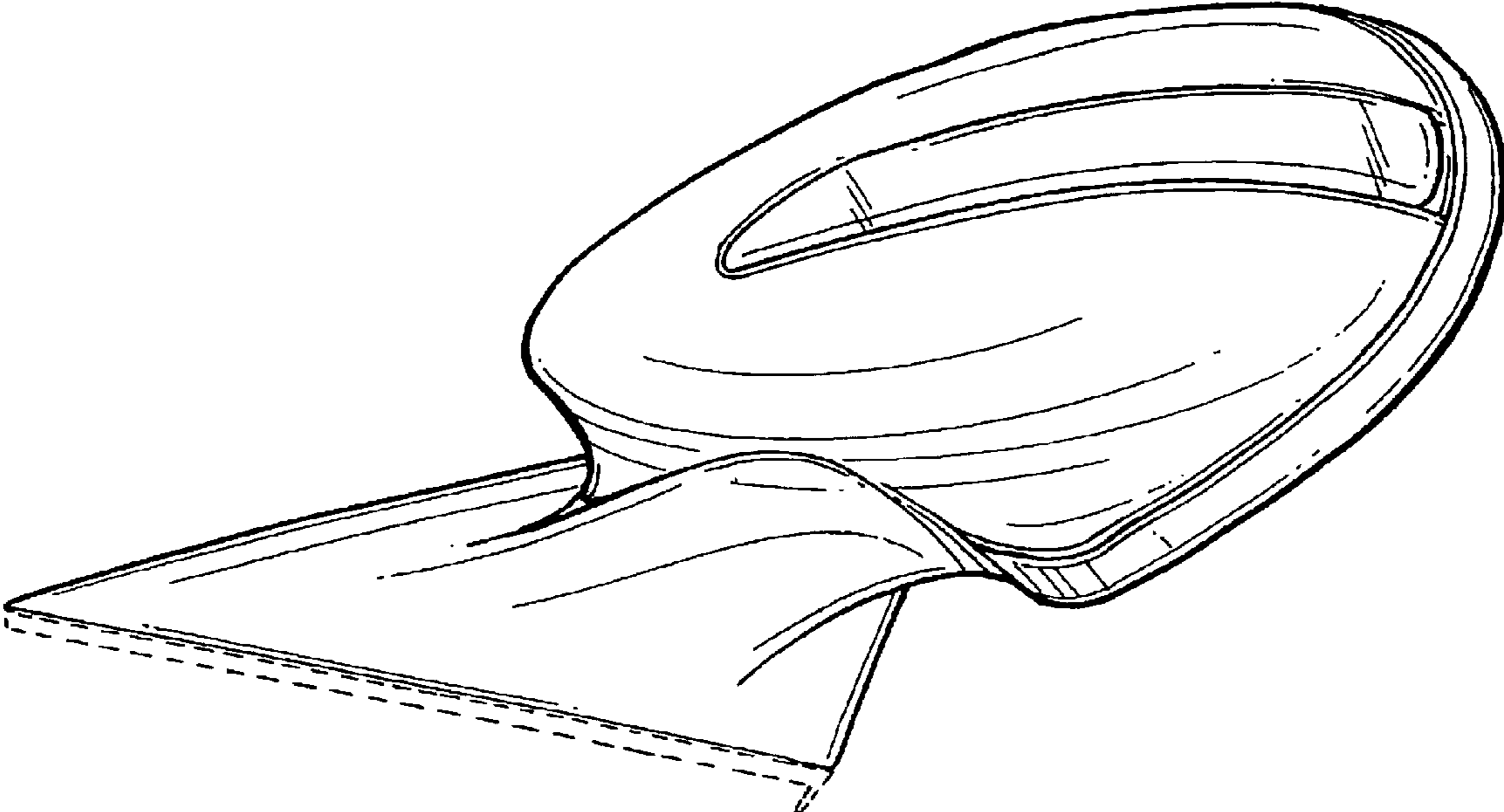

FIG. 1

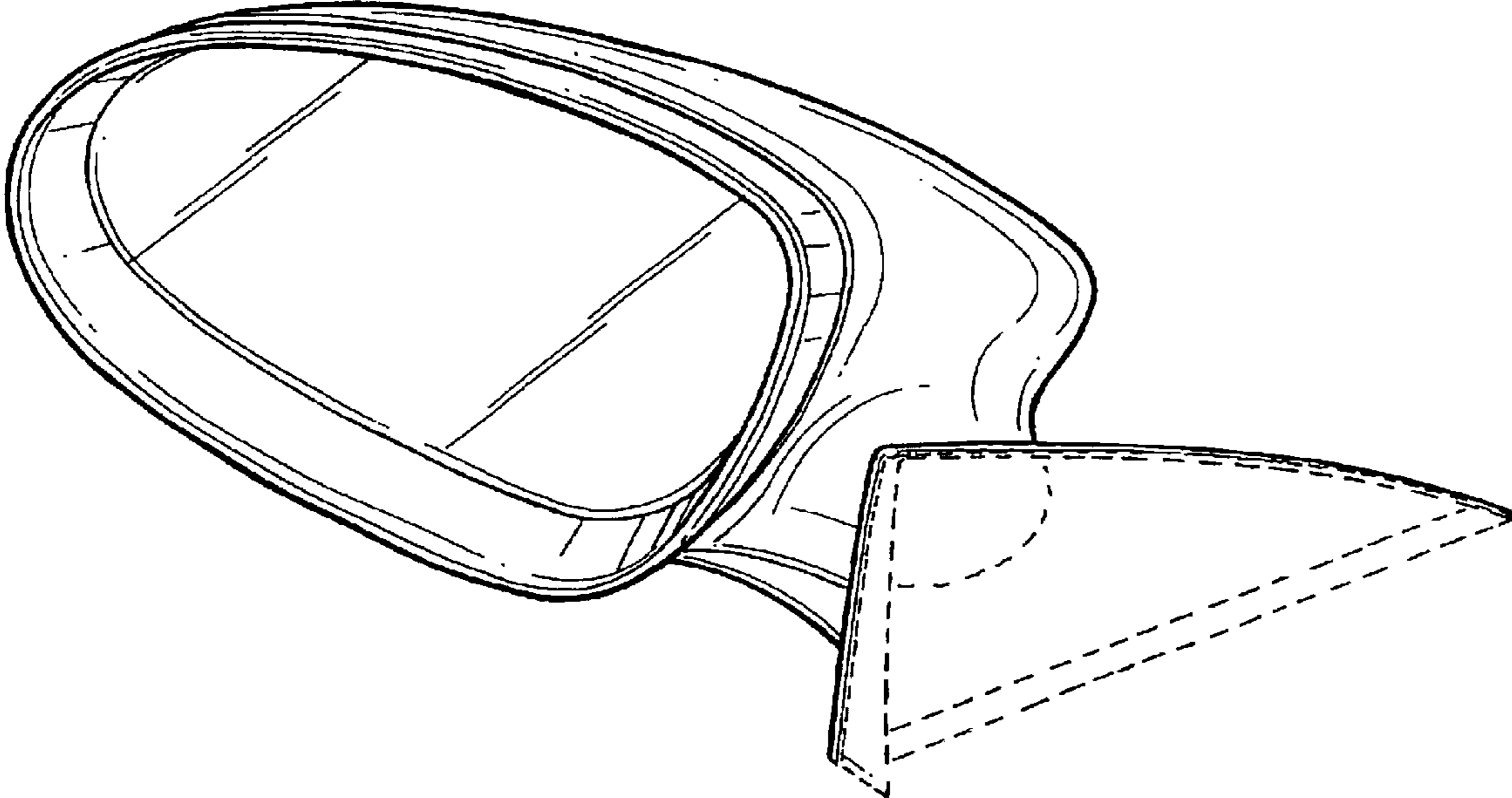

FIG. 2

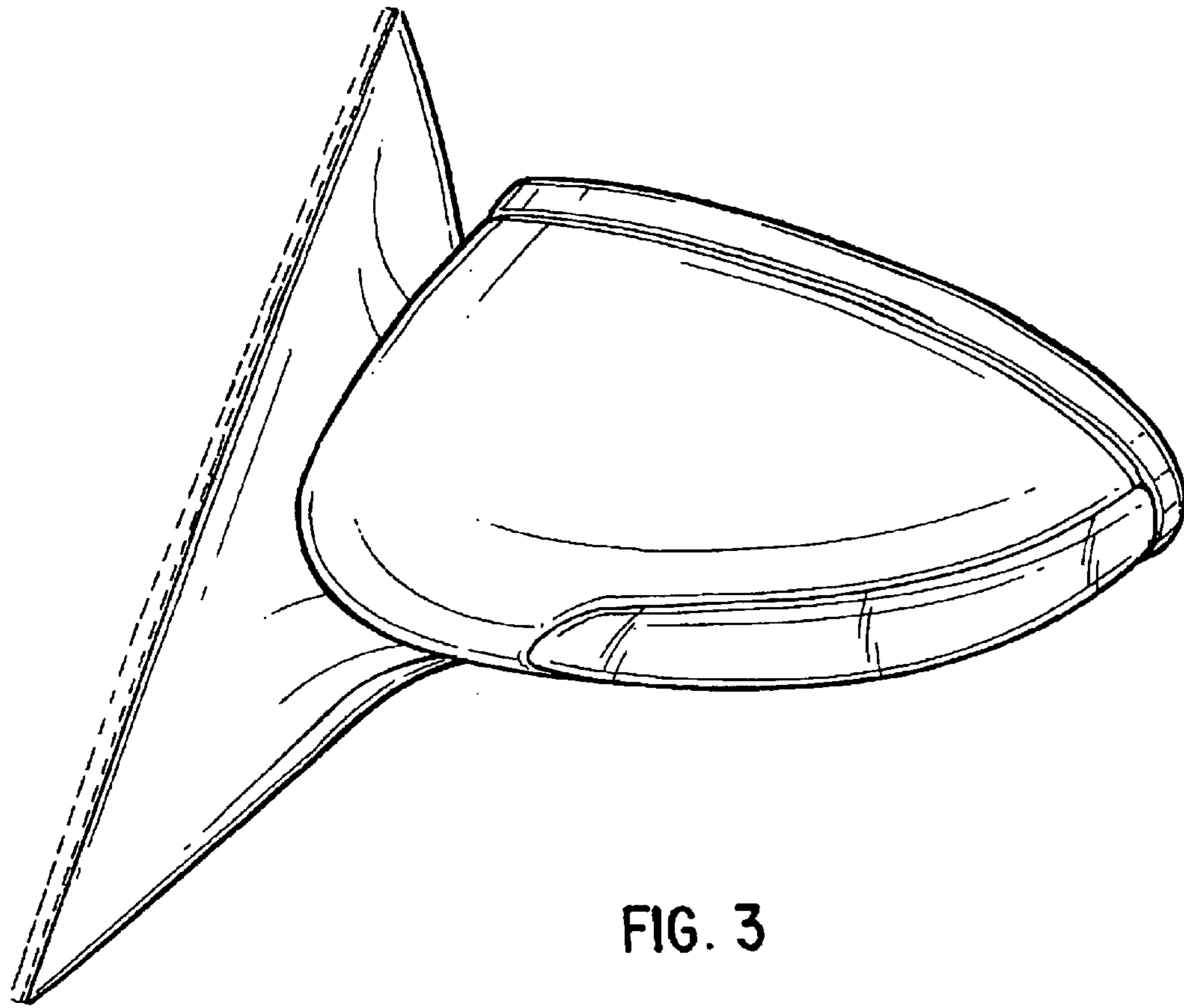

FIG. 3

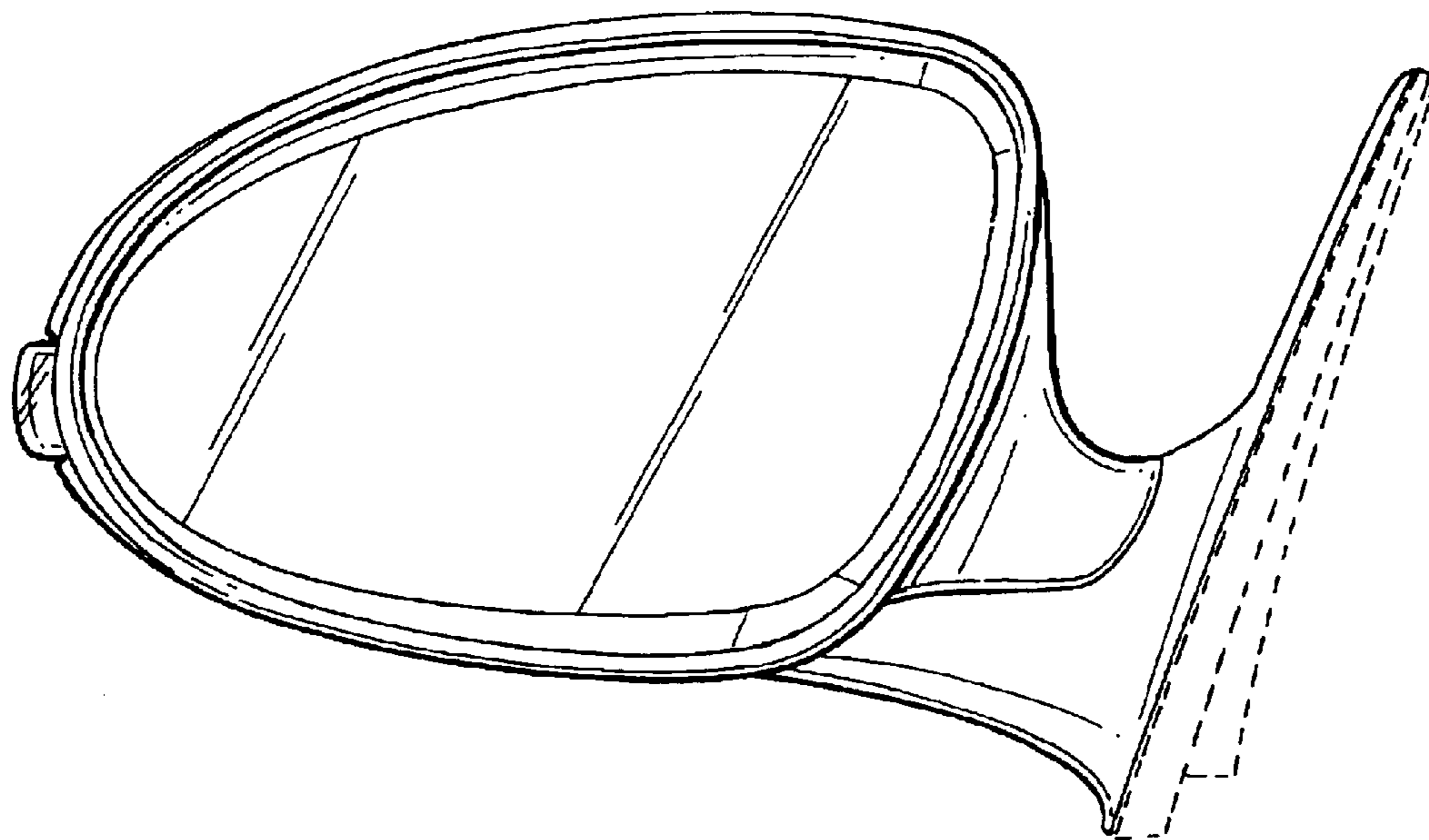

FIG. 4

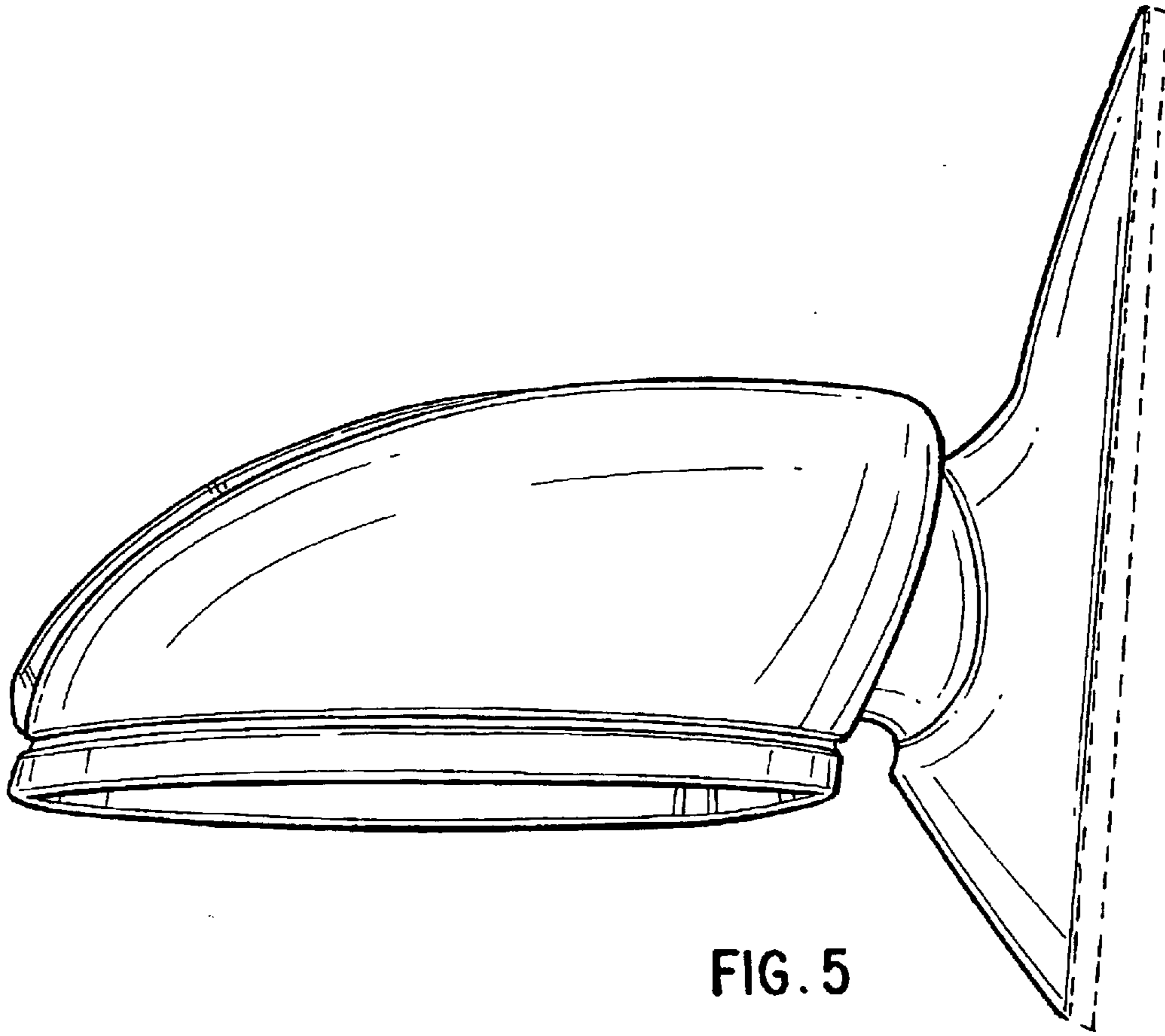

FIG. 5

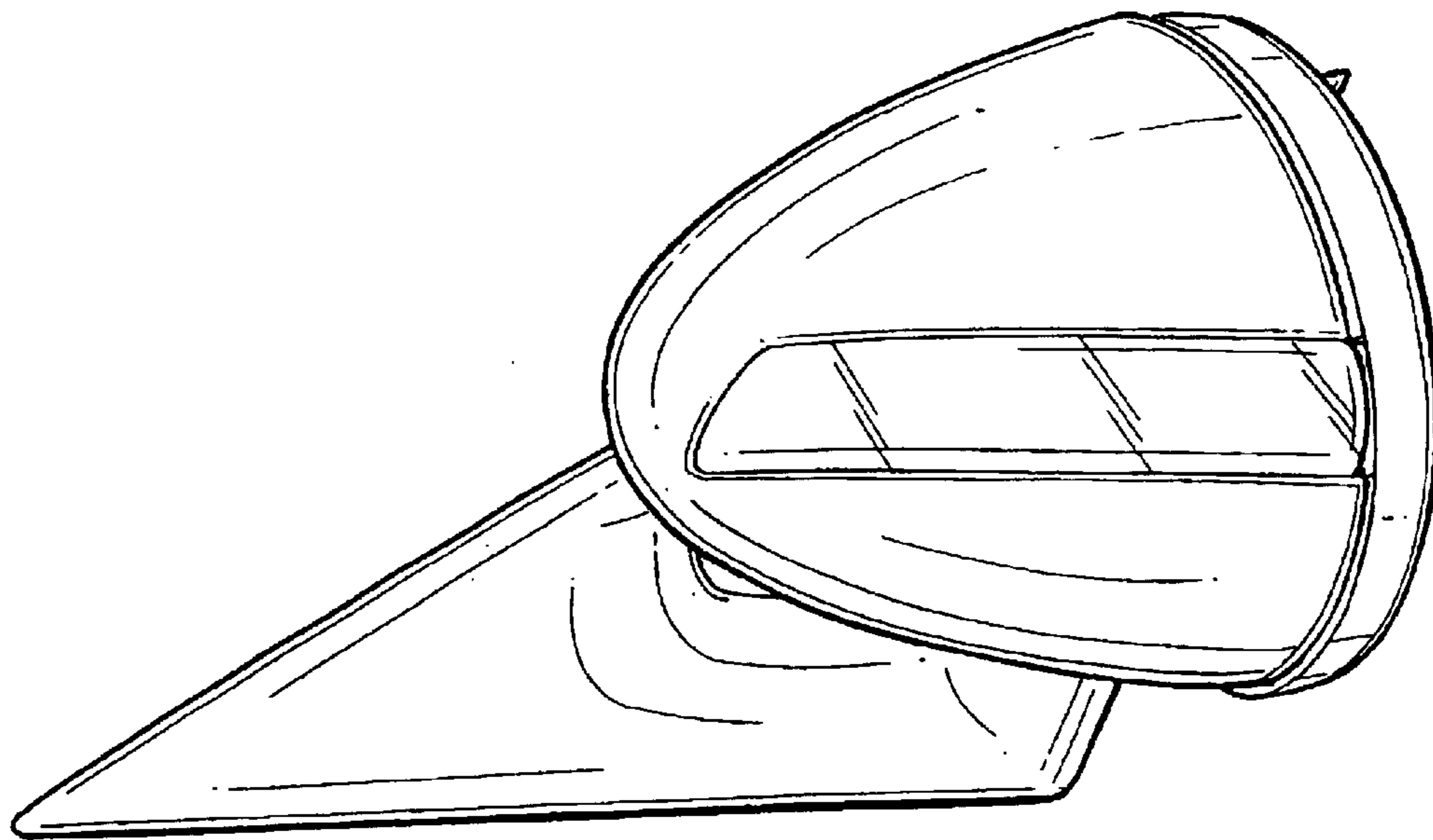

FIG. 6

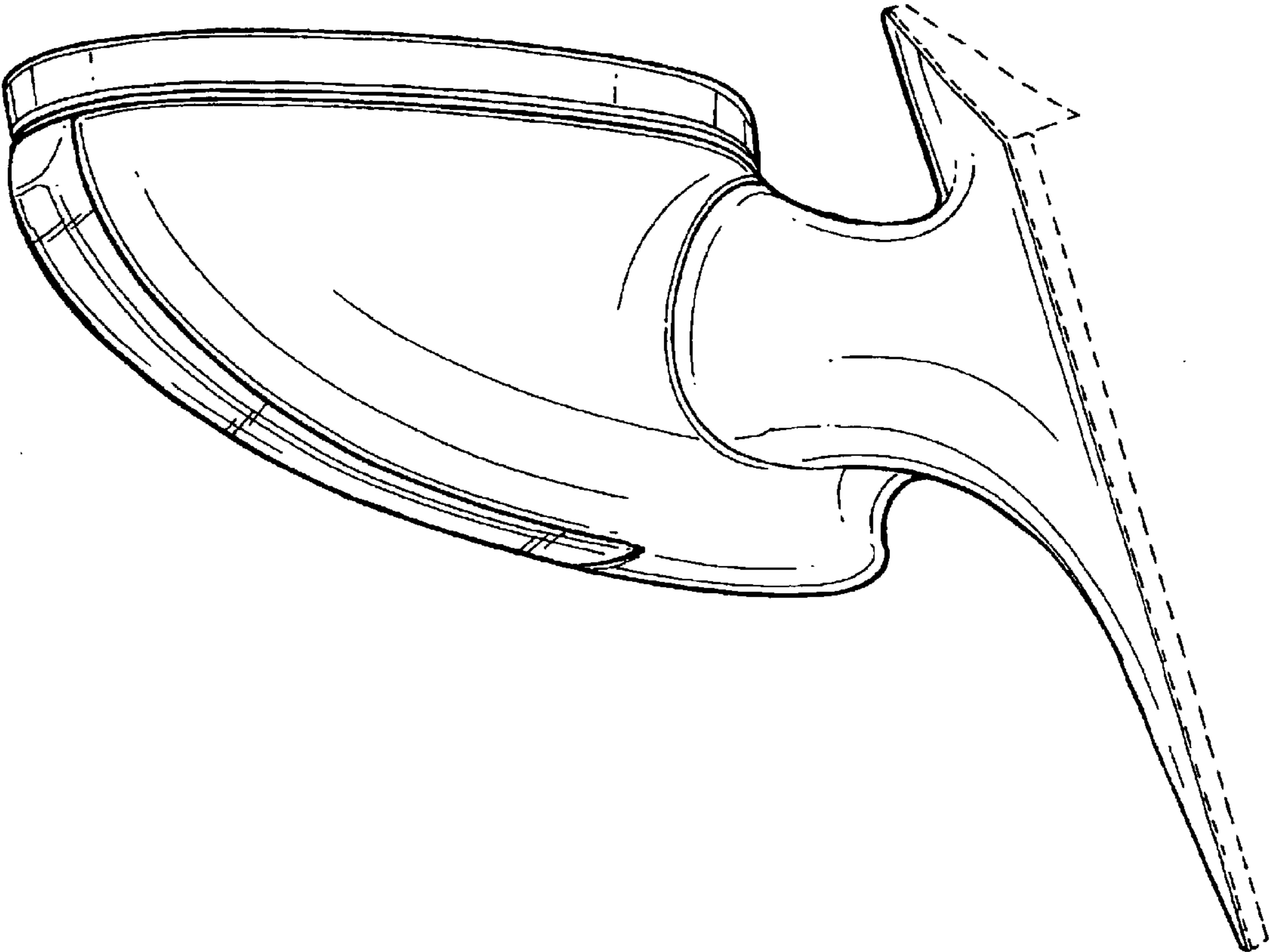

FIG. 7

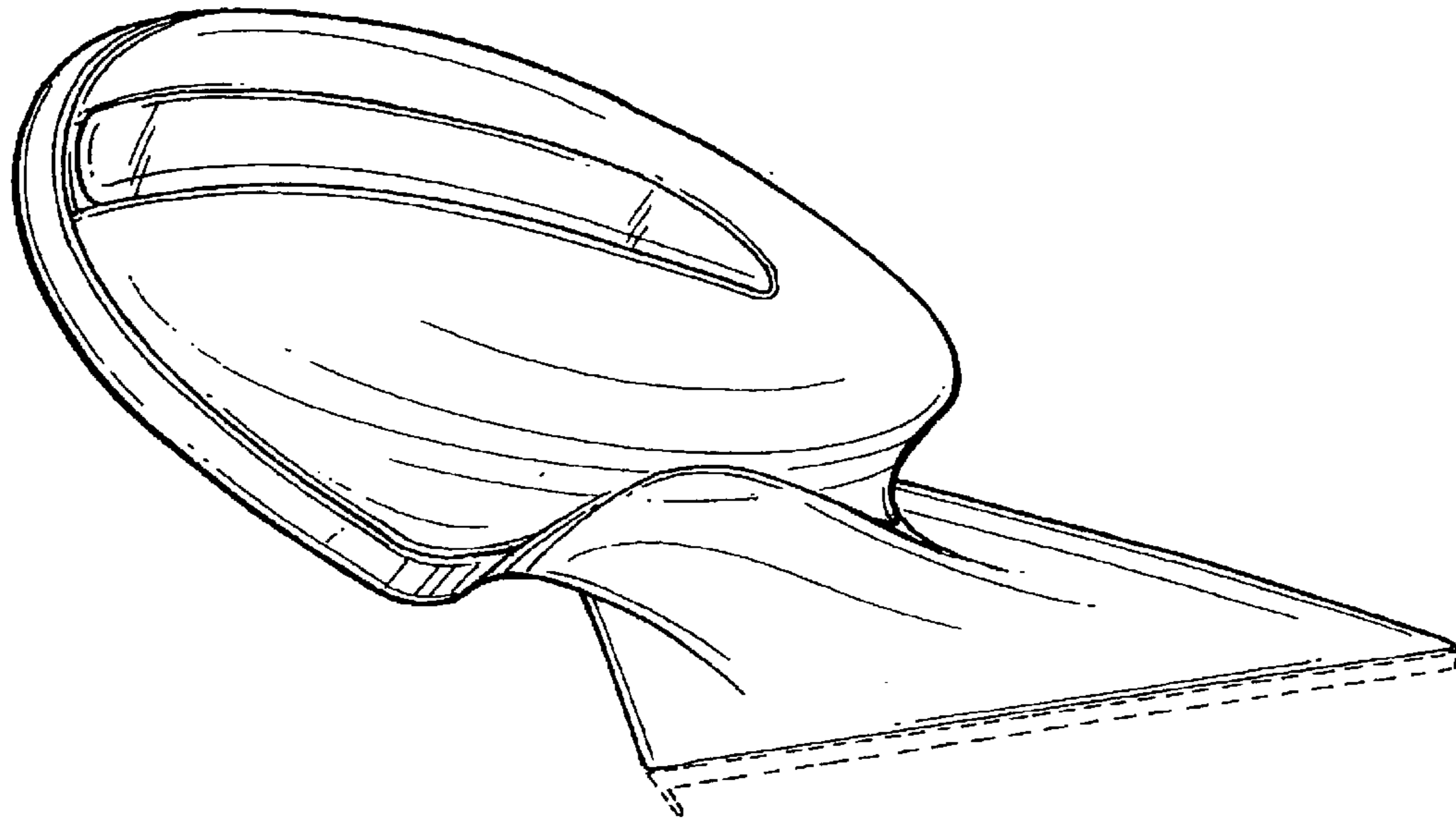

FIG. 8

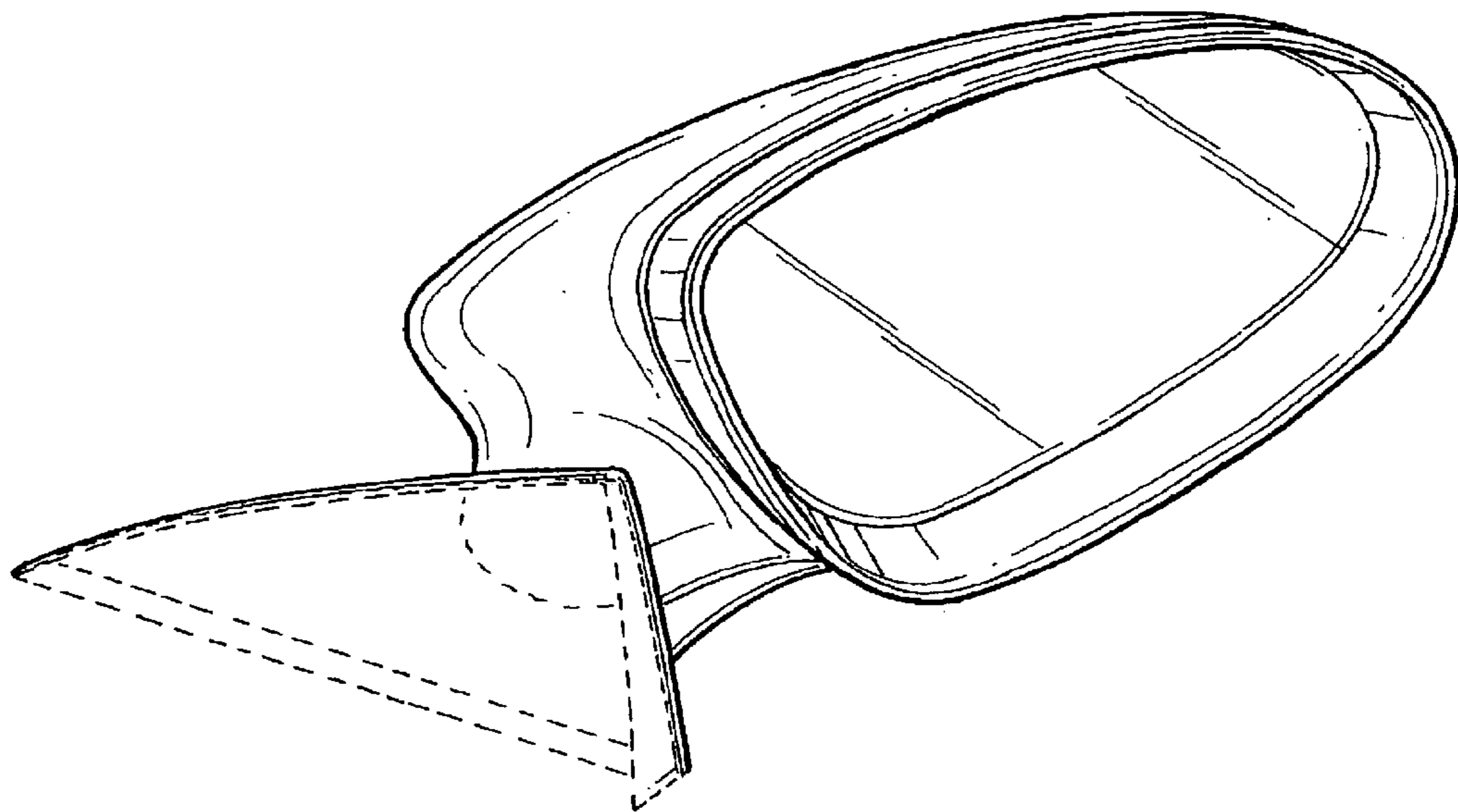

FIG. 9

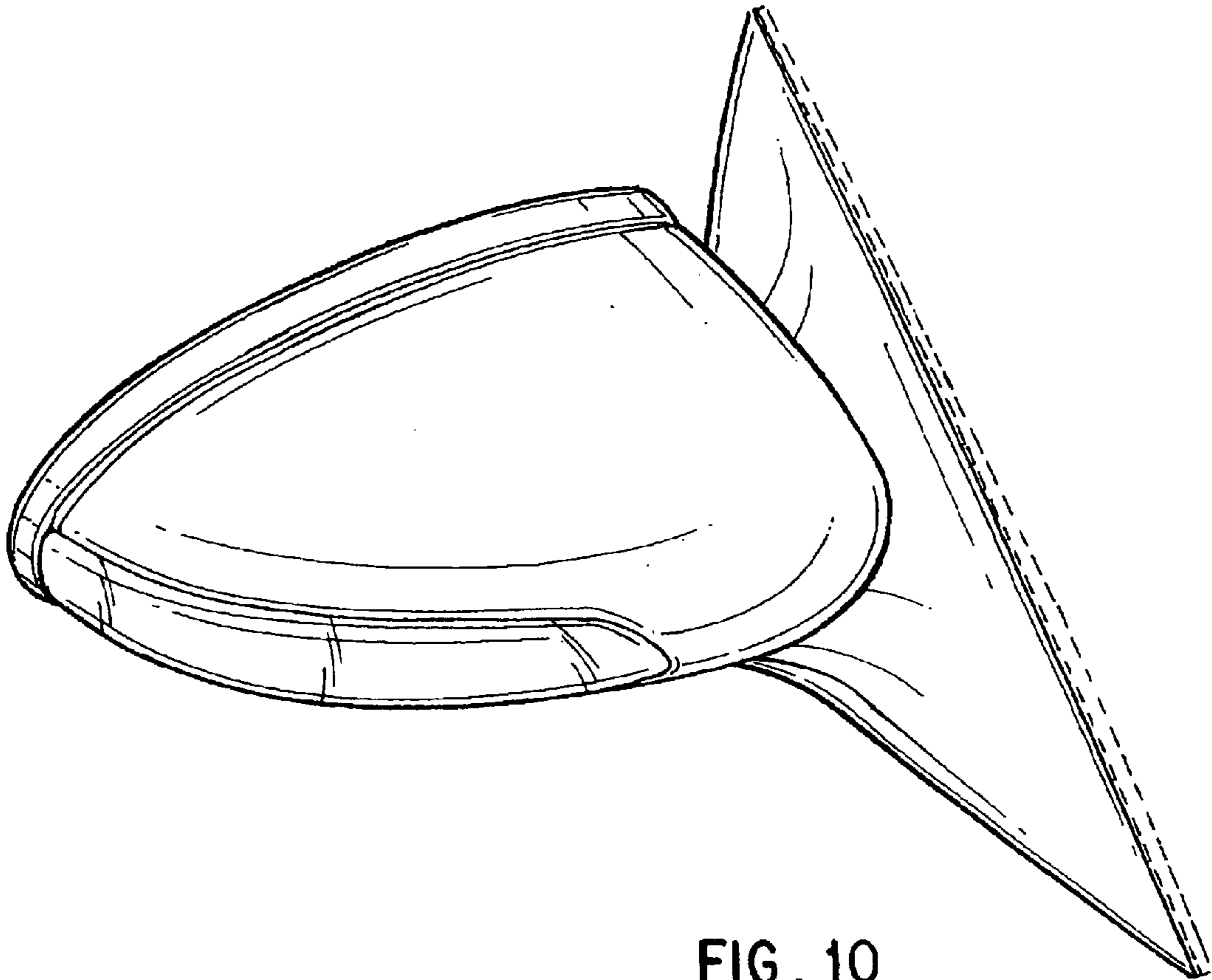

FIG. 10

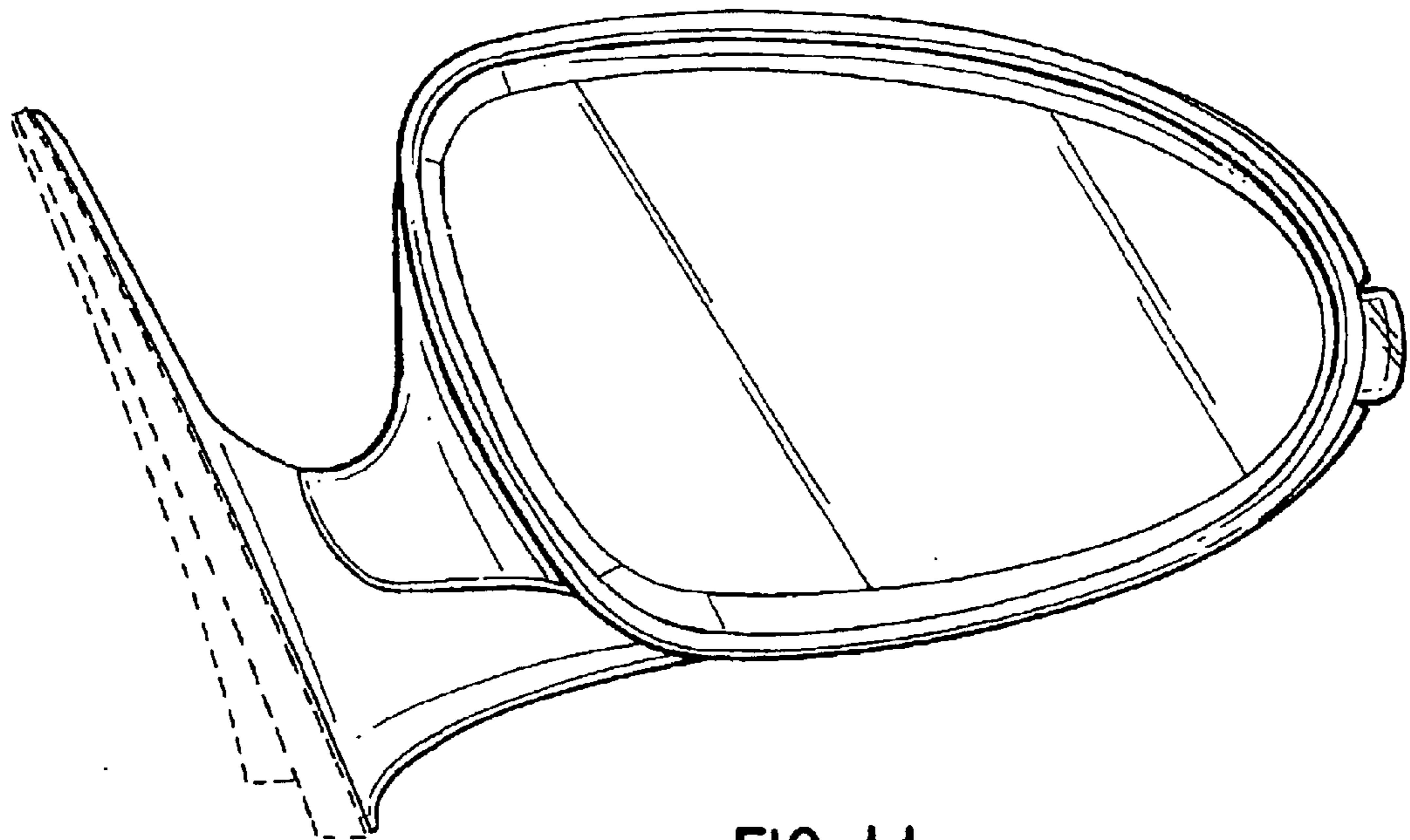

FIG. 11

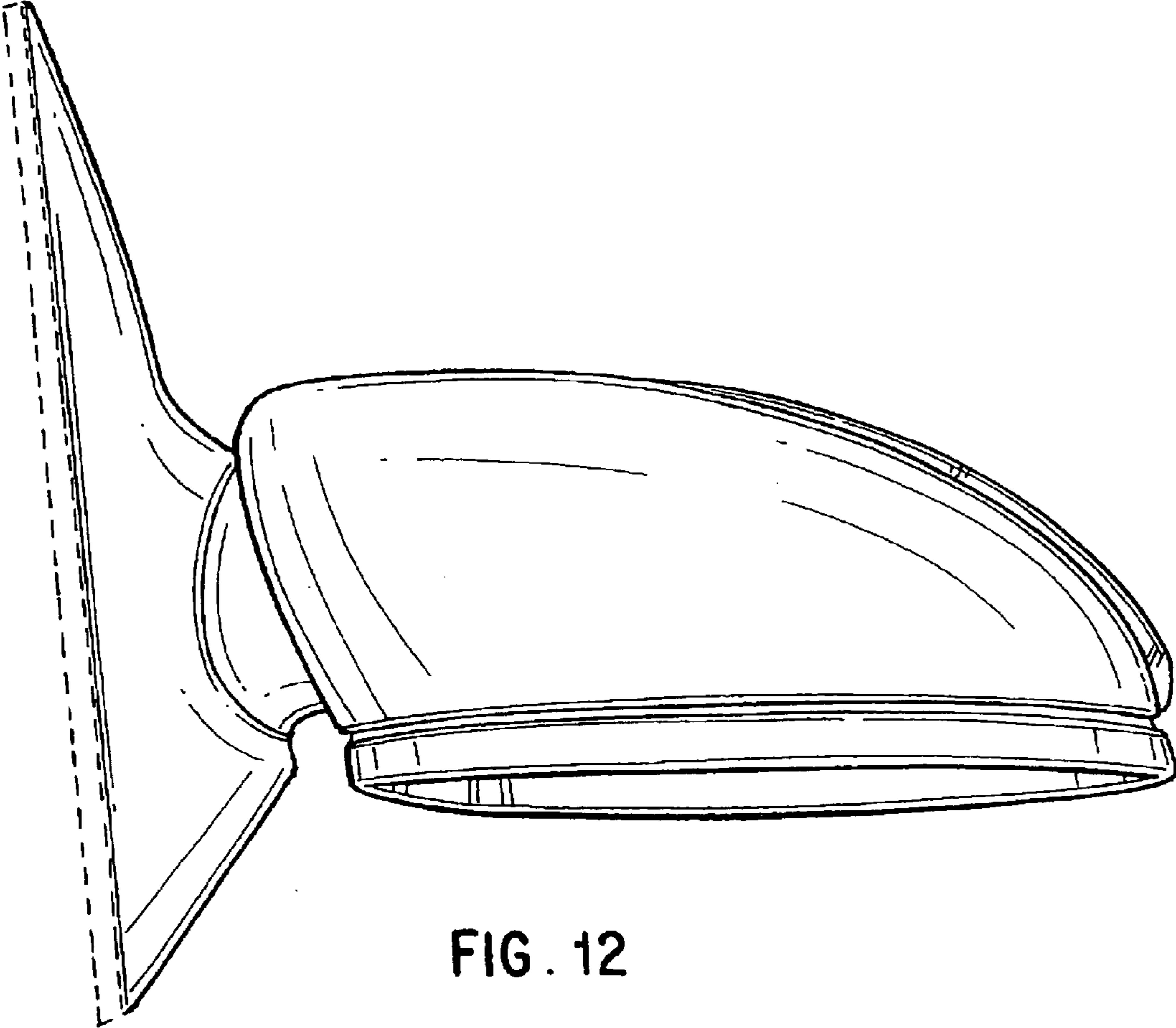

FIG. 12

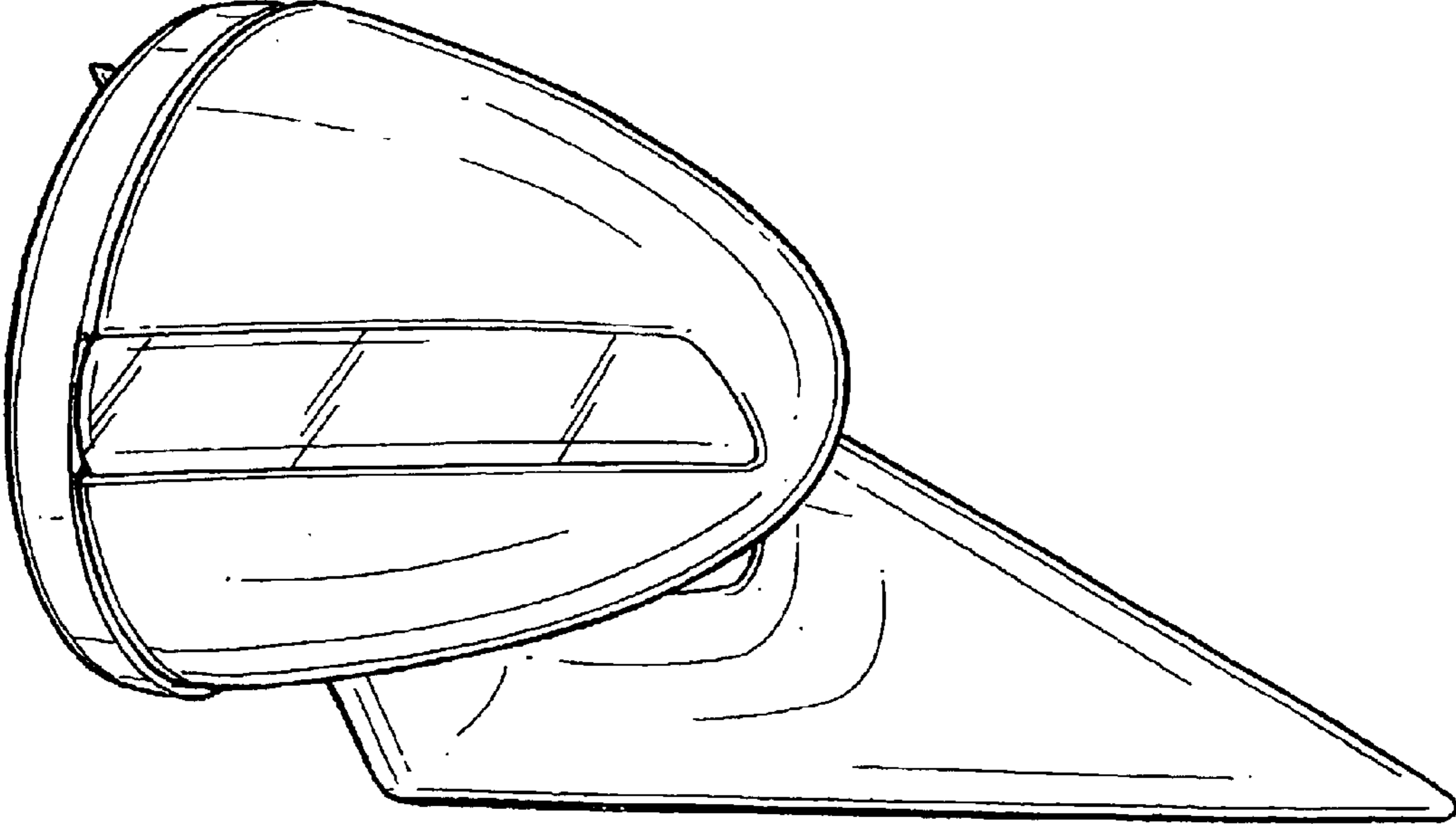

FIG. 13

