

US00D506120S

(12) **United States Design Patent**
Straka, Jr. et al.

(10) **Patent No.: US D506,120 S**
(45) **Date of Patent: ** Jun. 14, 2005**

(54) **MULTI-DIRECTIONAL ROTARY-PAWL LATCH**

(75) Inventors: **Robert Lewis Straka, Jr.**, Phoenixville, PA (US); **Claes Magnusson**, Stockholm (SE)

(73) Assignee: **Southco, Inc.**, Concordville, PA (US)

(**) Term: **14 Years**

(21) Appl. No.: **29/200,725**

(22) Filed: **Mar. 3, 2004**

Related U.S. Application Data

(63) Continuation of application No. 10/784,706, filed on Feb. 22, 2004.

(51) **LOC (8) Cl. 08-07**

(52) **U.S. Cl. D8/331**

(58) **Field of Search** D8/330, 331, 336, D8/343, 302, 339; 292/237, 96, DIG. 30, DIG. 31, 137, 336.5, 63-67; 70/91, 97, 94, 77-79, 206, 102, 210

(56) **References Cited**

U.S. PATENT DOCUMENTS

4,192,536	A	3/1980	Laureano	
4,706,478	A *	11/1987	Swan et al.	70/28
D324,636	S *	3/1992	Schlack et al.	D8/331
5,234,238	A *	8/1993	Takimoto	292/216
5,609,373	A *	3/1997	Gromotka	292/229
5,927,772	A	7/1999	Antonucci et al.	
5,984,383	A *	11/1999	Parikh et al.	292/121
D429,141	S *	8/2000	Antonucci et al.	D8/331
6,109,669	A *	8/2000	Pinkow	292/175
D452,808	S *	1/2002	Kyle	D8/331
D459,192	S *	6/2002	Weinerman et al.	D8/338
6,460,902	B1	10/2002	Kyle	
D475,602	S *	6/2003	McCloskey	D8/331
D489,959	S *	5/2004	Jackson et al.	D8/331
2003/0025339	A1	2/2003	Vitry et al.	

* cited by examiner

Primary Examiner—Prabhakar Deshmukh
(74) *Attorney, Agent, or Firm*—Paul & Paul

(57) **CLAIM**

The ornamental design for a multi-directional rotary-pawl latch, as shown and described.

DESCRIPTION

FIG. 1 is a perspective view of a multi-directional rotary-pawl latch embodying our new design, showing the handle in a folded-down position and the lower housing in a first angular orientation relative to the upper housing;

FIG. 2 is a front view thereof;

FIG. 3 is a rear view thereof;

FIG. 4 is a right side view thereof;

FIG. 5 is a left side view thereof;

FIG. 6 is a top view thereof;

FIG. 7 is a bottom view thereof;

FIG. 8 is a perspective view of the multi-directional rotary-pawl latch of FIG. 1 showing the handle in the raised position;

FIG. 9 is a front view of the multi-directional rotary-pawl latch of FIG. 8;

FIG. 10 is a rear view of the multi-directional rotary-pawl latch of FIG. 8;

FIG. 11 is a right side view of the multi-directional rotary-pawl latch of FIG. 8;

FIG. 12 is a left side view of the multi-directional rotary-pawl latch of FIG. 8;

FIG. 13 is a top view of the multi-directional rotary-pawl latch of FIG. 8;

FIG. 14 is a bottom view of the multi-directional rotary-pawl latch of FIG. 8;

FIG. 15 is a perspective view of the multi-directional rotary-pawl latch of FIG. 1, showing the handle in a folded-down position and the lower housing in a second angular orientation relative to the upper housing;

FIG. 16 is a front view thereof;

FIG. 17 is a rear view thereof;

FIG. 18 is a right side view thereof;

FIG. 19 is a left side view thereof;

FIG. 20 is a top view thereof;

FIG. 21 is a bottom view thereof;

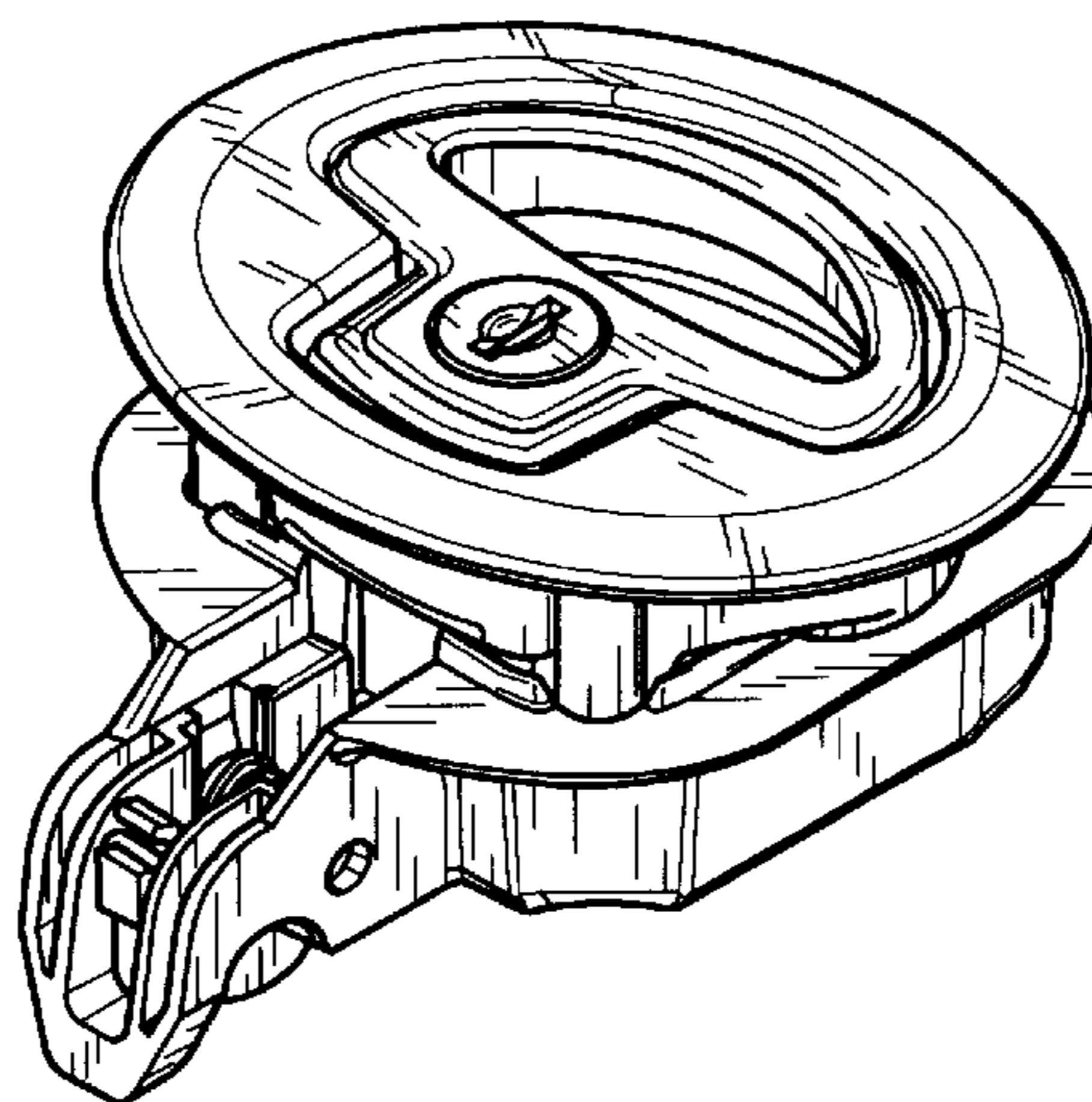

FIG. 22 is a perspective view of the multi-directional rotary-pawl latch of FIG. 15 showing the handle in the raised position;

FIG. 23 is a front view of the multi-directional rotary-pawl latch of FIG. 22;

FIG. 24 is a rear view of the multi-directional rotary-pawl latch of FIG. 22;

FIG. 25 is a right side view of the multi-directional rotary-pawl latch of FIG. 22;

FIG. 26 is a left side view of the multi-directional rotary-pawl latch of FIG. 22;

FIG. 27 is a top view of the multi-directional rotary-pawl latch of FIG. 22;

FIG. 28 is a bottom view of the multi-directional rotary-pawl latch of FIG. 22;

FIG. 29 is a perspective view of the multi-directional rotary-pawl latch of FIG. 1, showing the handle in a folded-down position and the lower housing in a third angular orientation relative to the upper housing;

FIG. 30 is a front view thereof;

FIG. 31 is a rear view thereof;

FIG. 32 is a right side view thereof;

FIG. 33 is a left side view thereof;

FIG. 34 is a top view thereof;

FIG. 35 is a bottom view thereof;

FIG. 36 is a perspective view of the multi-directional rotary-pawl latch of FIG. 29 showing the handle in the raised position;

FIG. 37 is a front view of the multi-directional rotary-pawl latch of FIG. 36;

FIG. 38 is a rear view of the multi-directional rotary-pawl latch of FIG. 36;

FIG. 39 is a right side view of the multi-directional rotary-pawl latch of FIG. 36;

FIG. 40 is a left side view of the multi-directional rotary-pawl latch of FIG. 36;

FIG. 41 is a top view of the multi-directional rotary-pawl latch of FIG. 36;

FIG. 42 is a bottom view of the multi-directional rotary-pawl latch of FIG. 36;

FIG. 43 is a perspective view of the multi-directional rotary-pawl latch of FIG. 1, showing the handle in a folded-down position and the lower housing in a fourth angular orientation relative to the upper housing;

FIG. 44 is a front view thereof;

FIG. 45 is a rear view thereof;

FIG. 46 is a right side view thereof;

FIG. 47 is a left side view thereof;

FIG. 48 is a top view thereof;

FIG. 49 is a bottom view thereof;

FIG. 50 is a perspective view of the multi-directional rotary-pawl latch of FIG. 43 showing the handle in the raised position;

FIG. 51 is a front view of the multi-directional rotary-pawl latch of FIG. 50;

FIG. 52 is a rear view of the multi-directional rotary-pawl latch of FIG. 50;

FIG. 53 is a right side view of the multi-directional rotary-pawl latch of FIG. 50;

FIG. 54 is a left side view of the multi-directional rotary-pawl latch of FIG. 50;

FIG. 55 is a top view of the multi-directional rotary-pawl latch of FIG. 50; and,

FIG. 56 is a bottom view of the multi-directional rotary-pawl latch of FIG. 50.

1 Claim, 16 Drawing Sheets

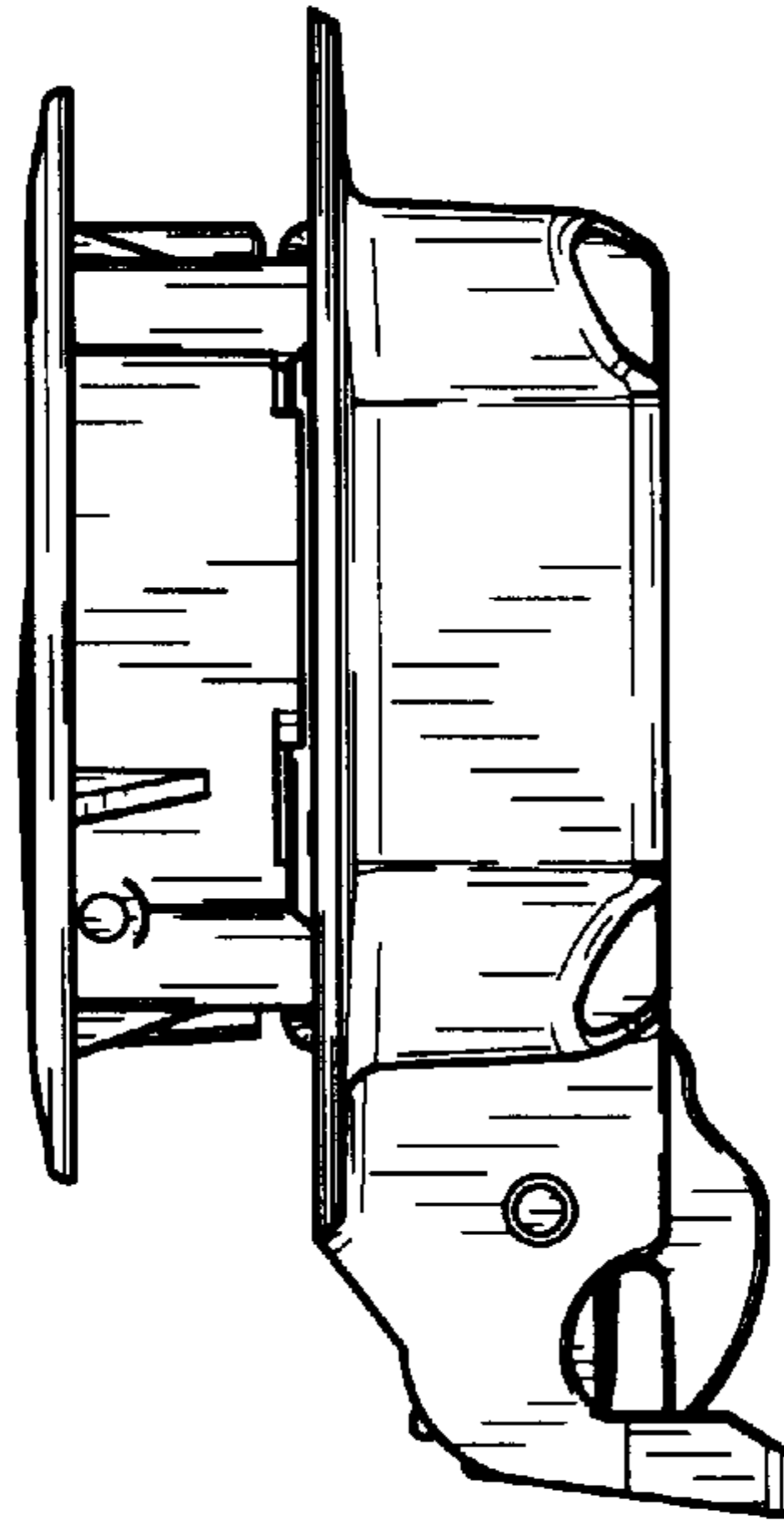
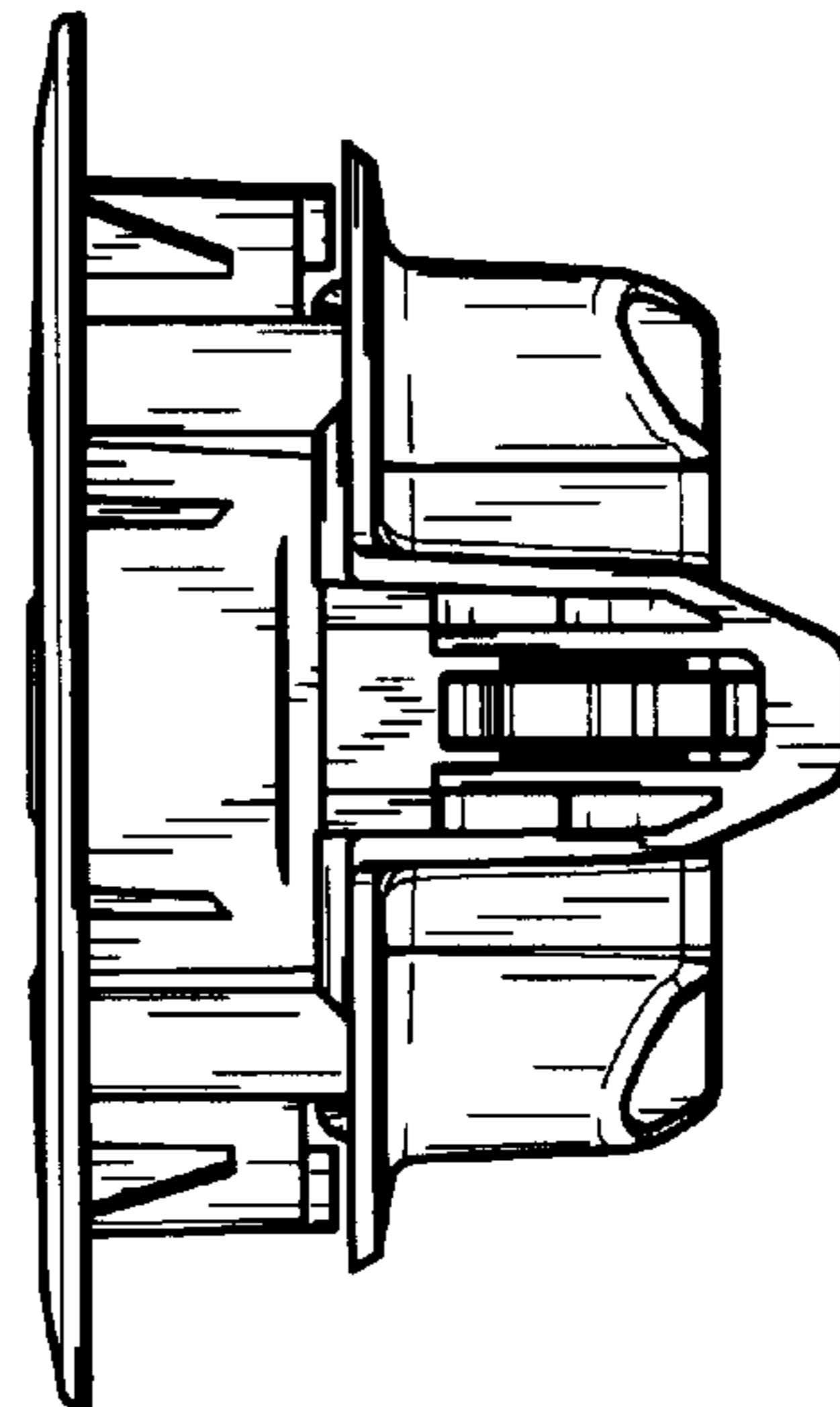
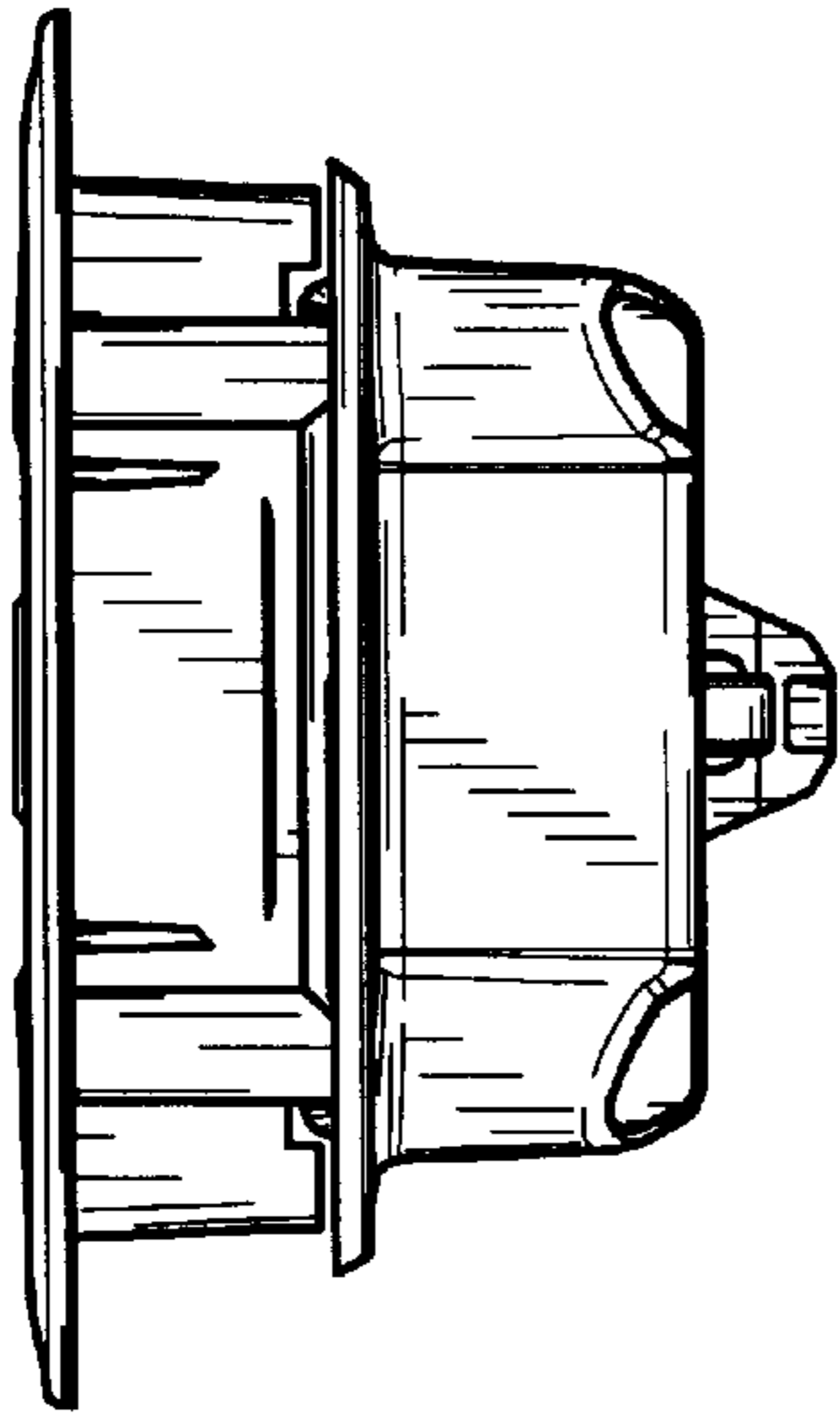
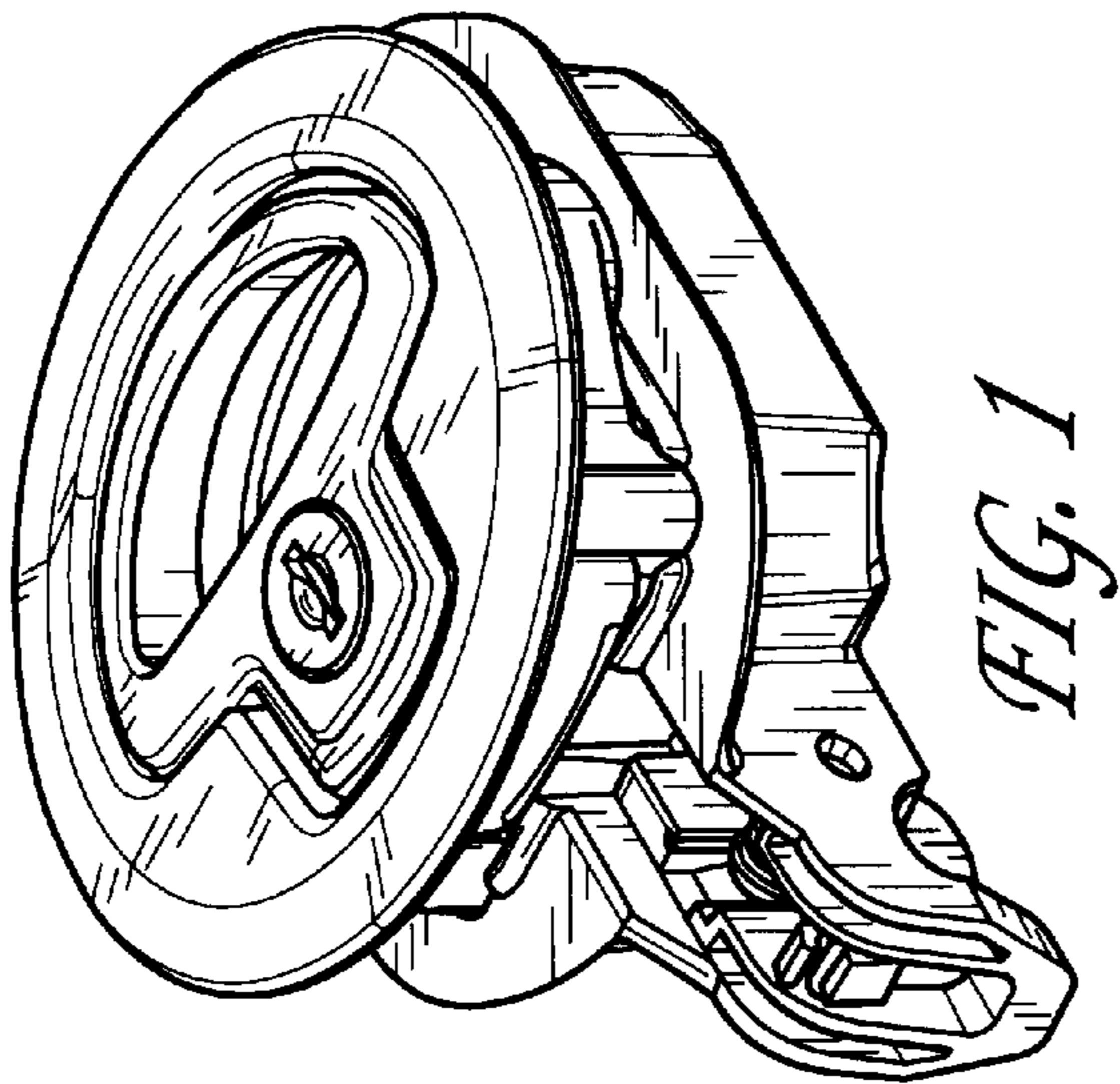



FIG. 5

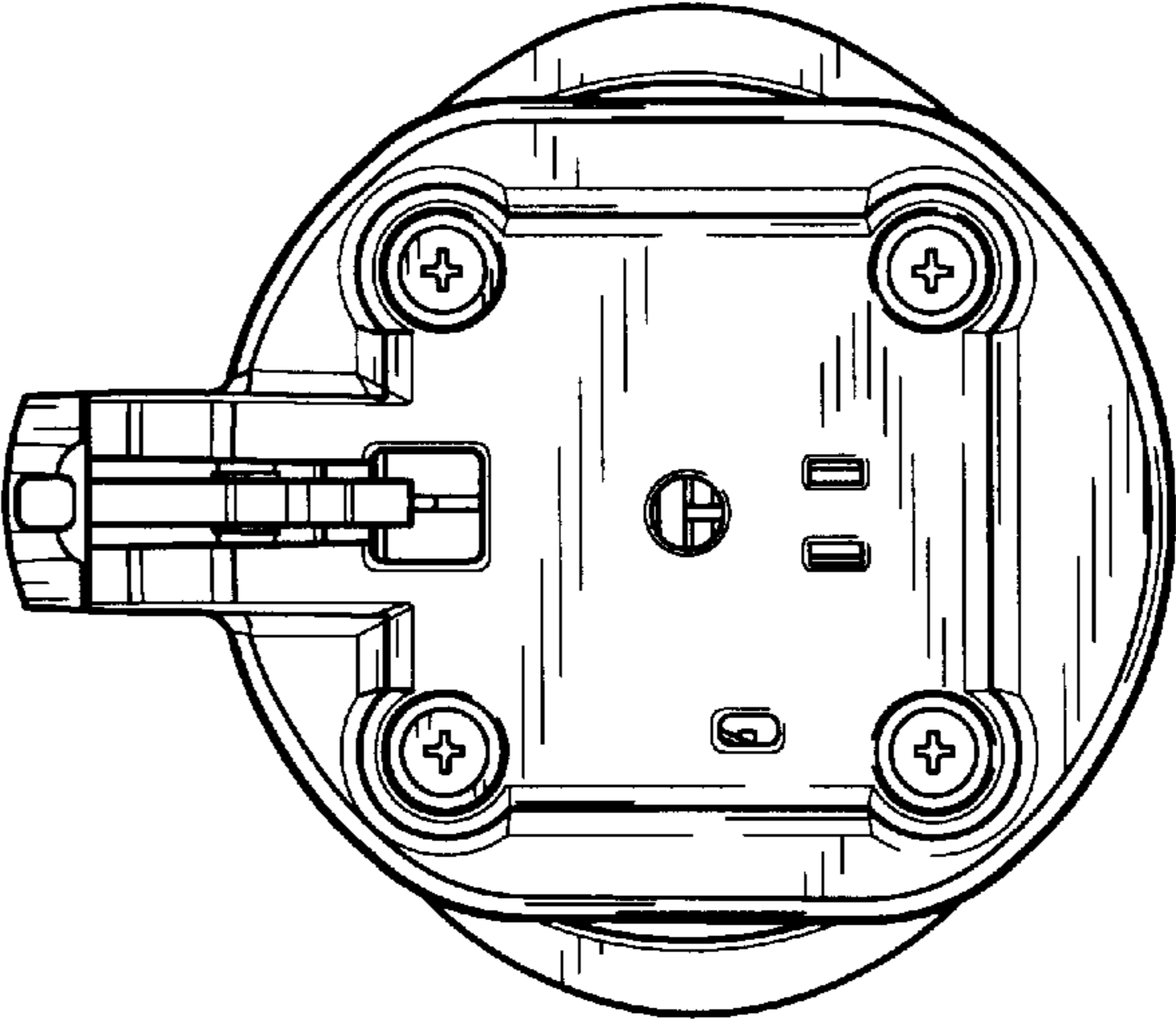

FIG. 7

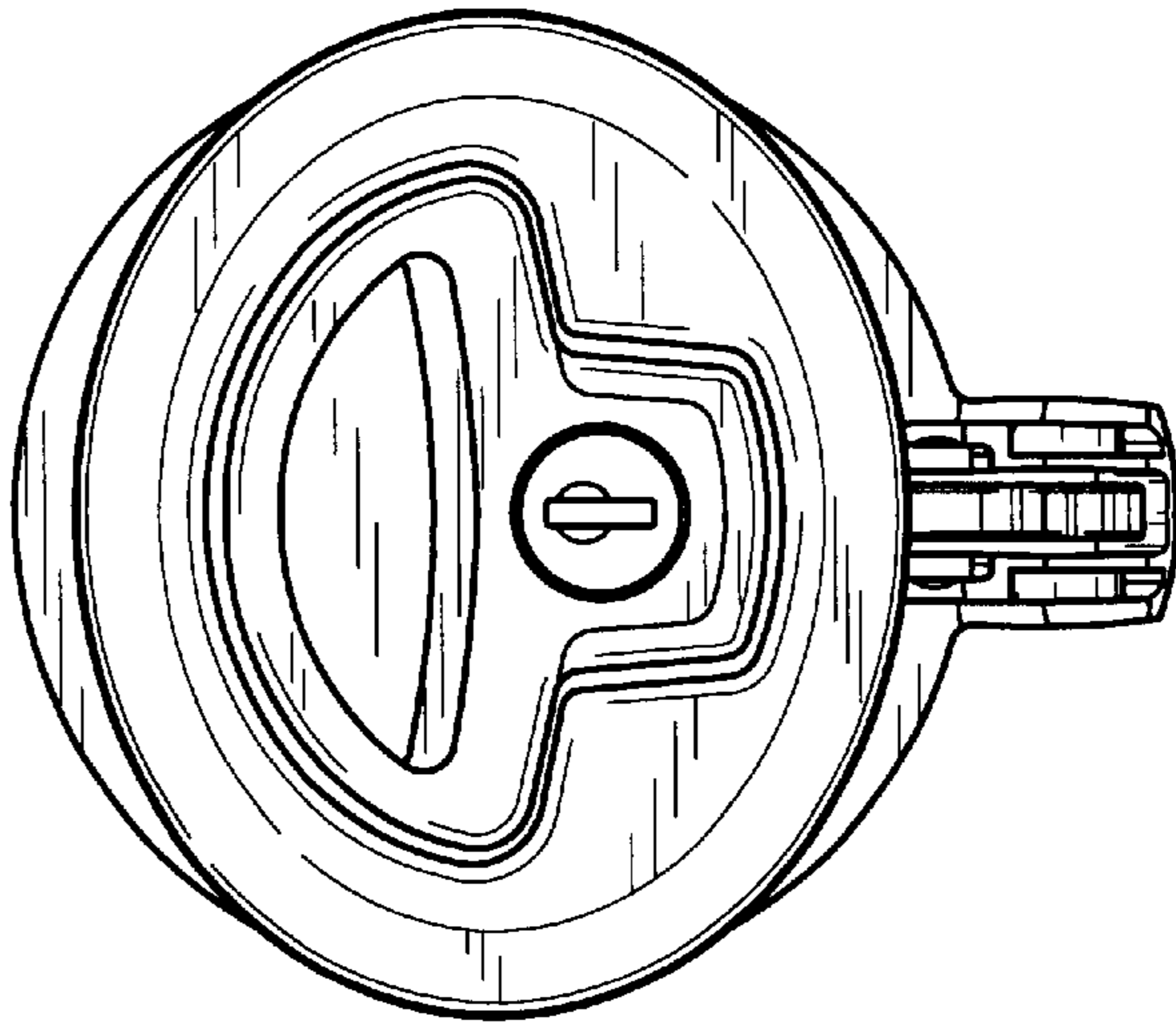

FIG. 6

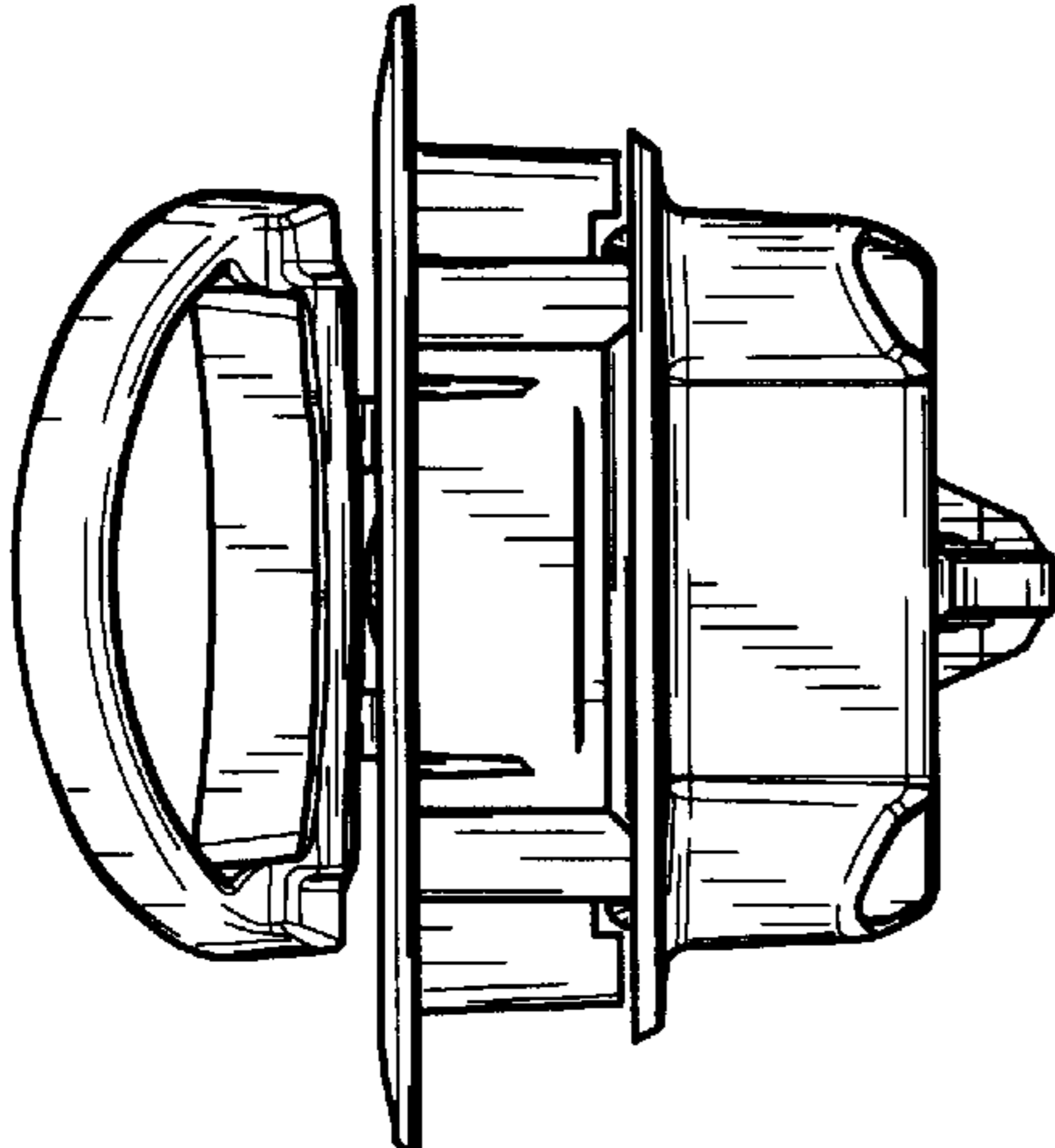

FIG. 9

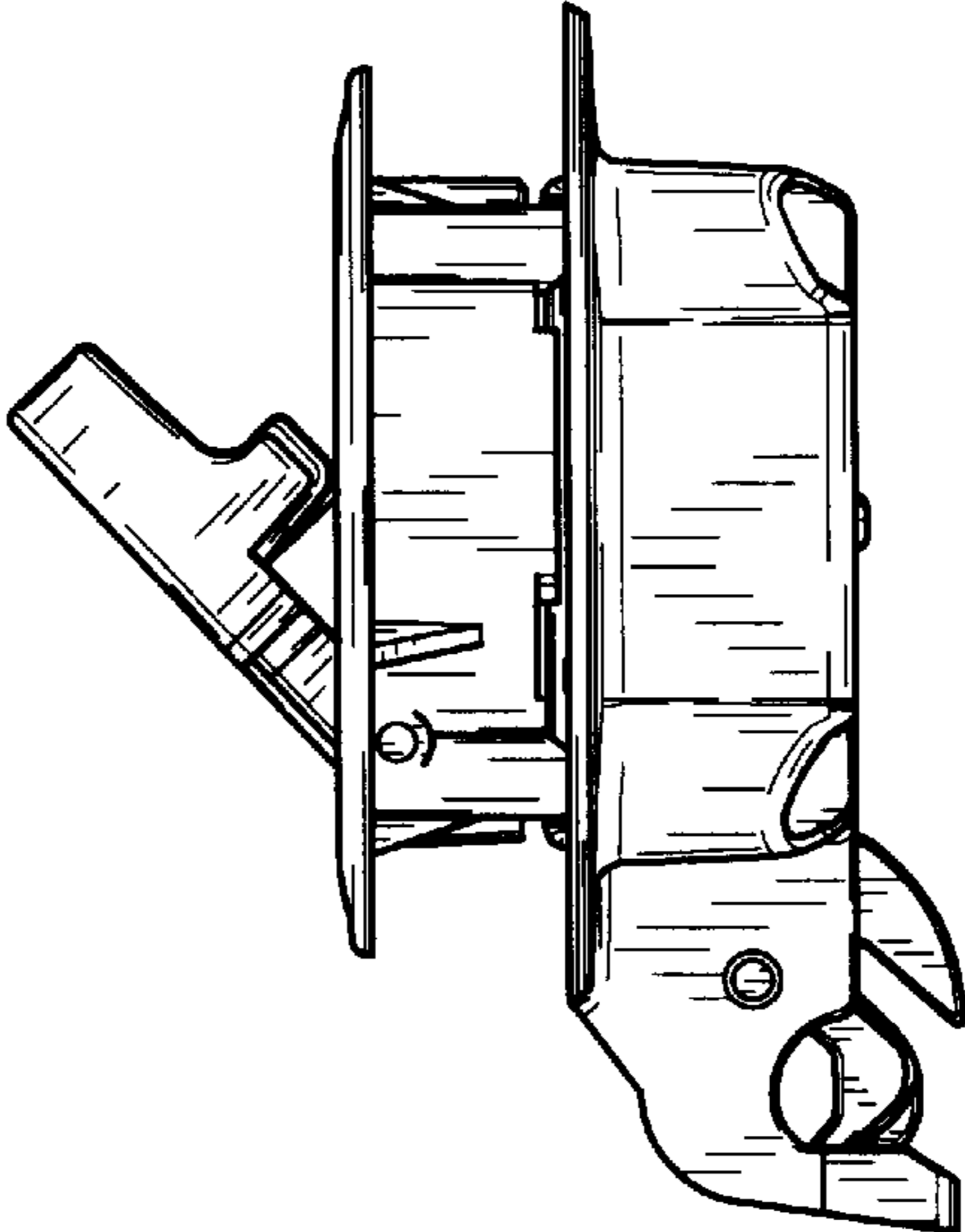

FIG. 11

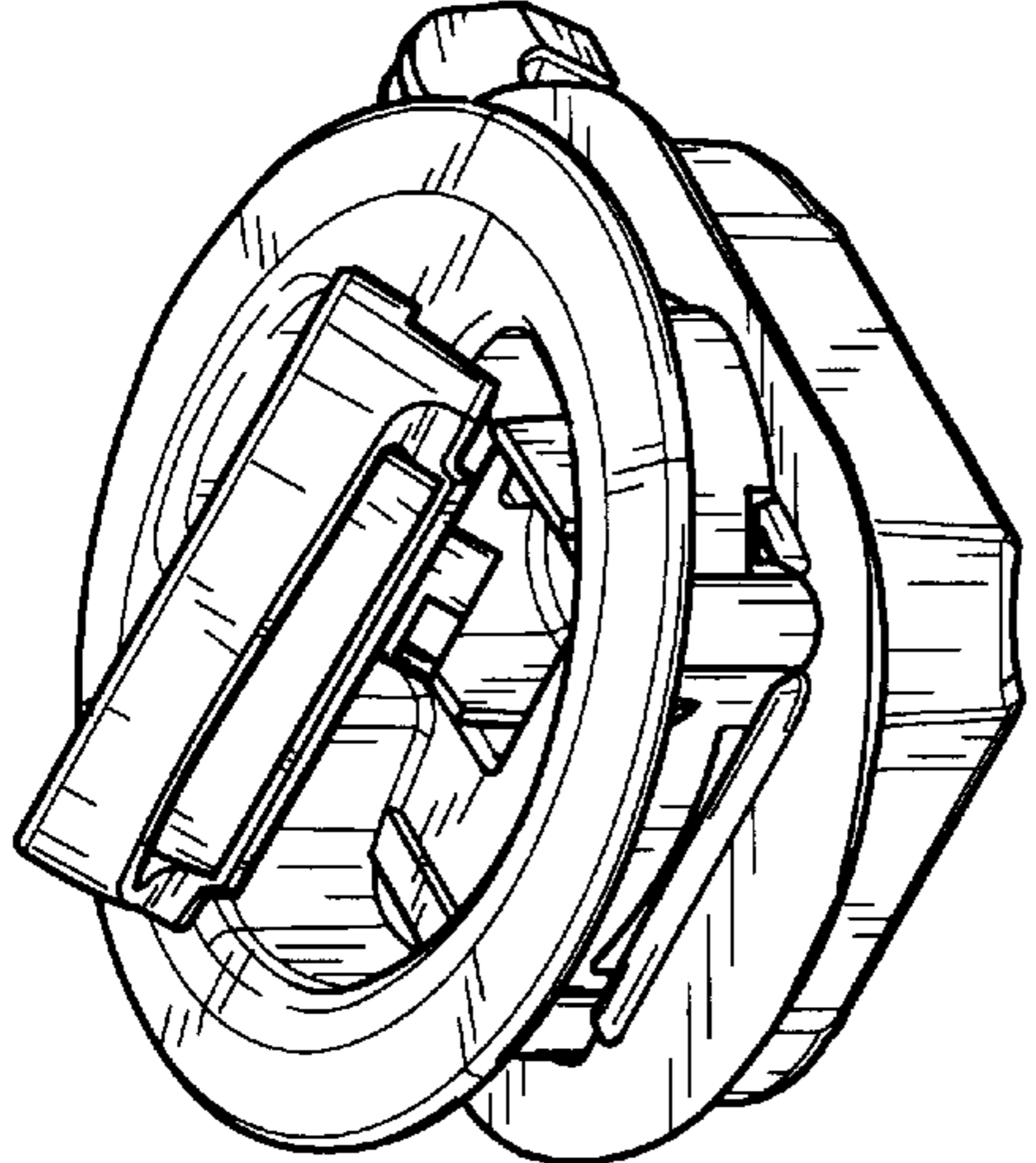

FIG. 8

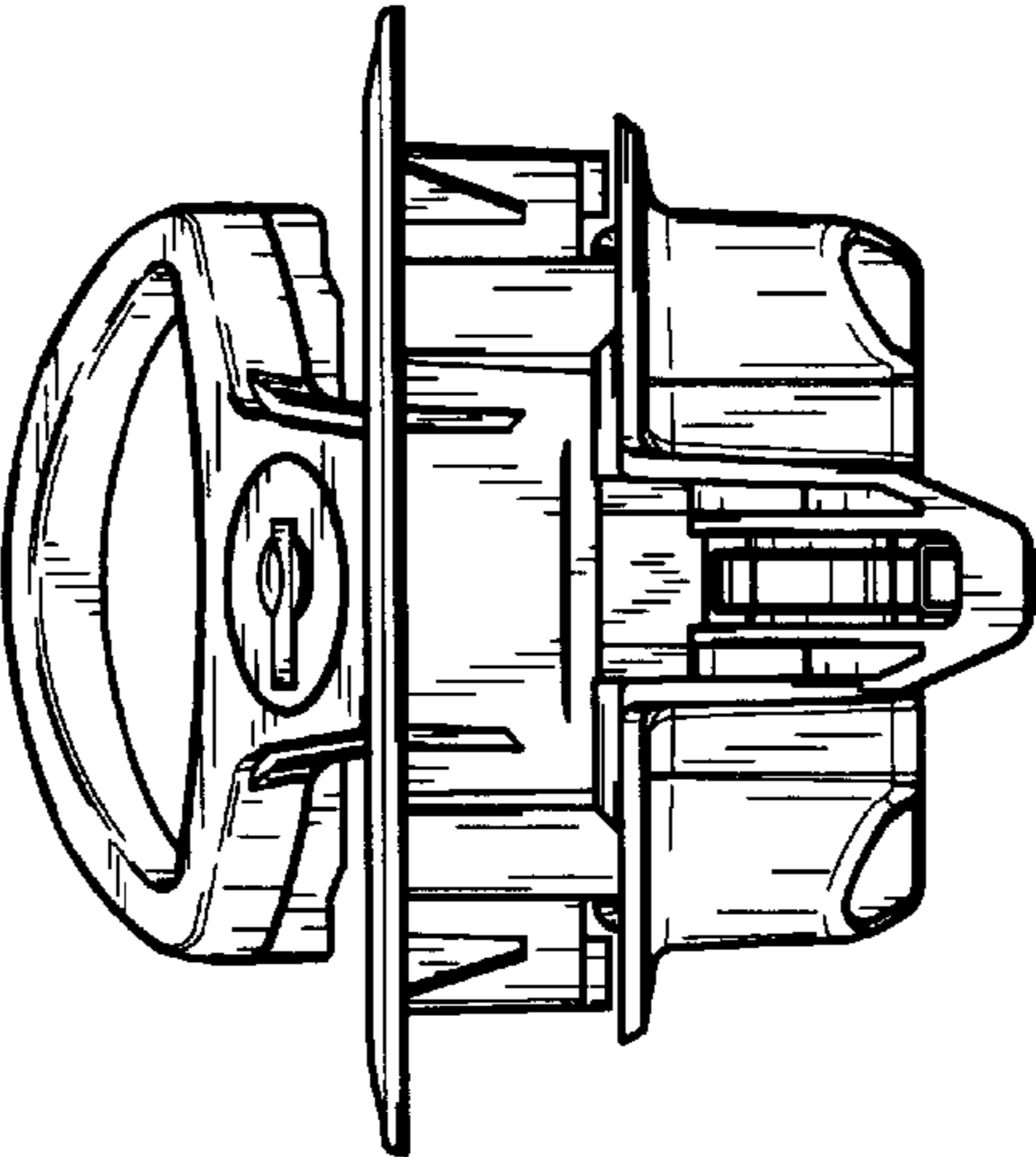

FIG. 10

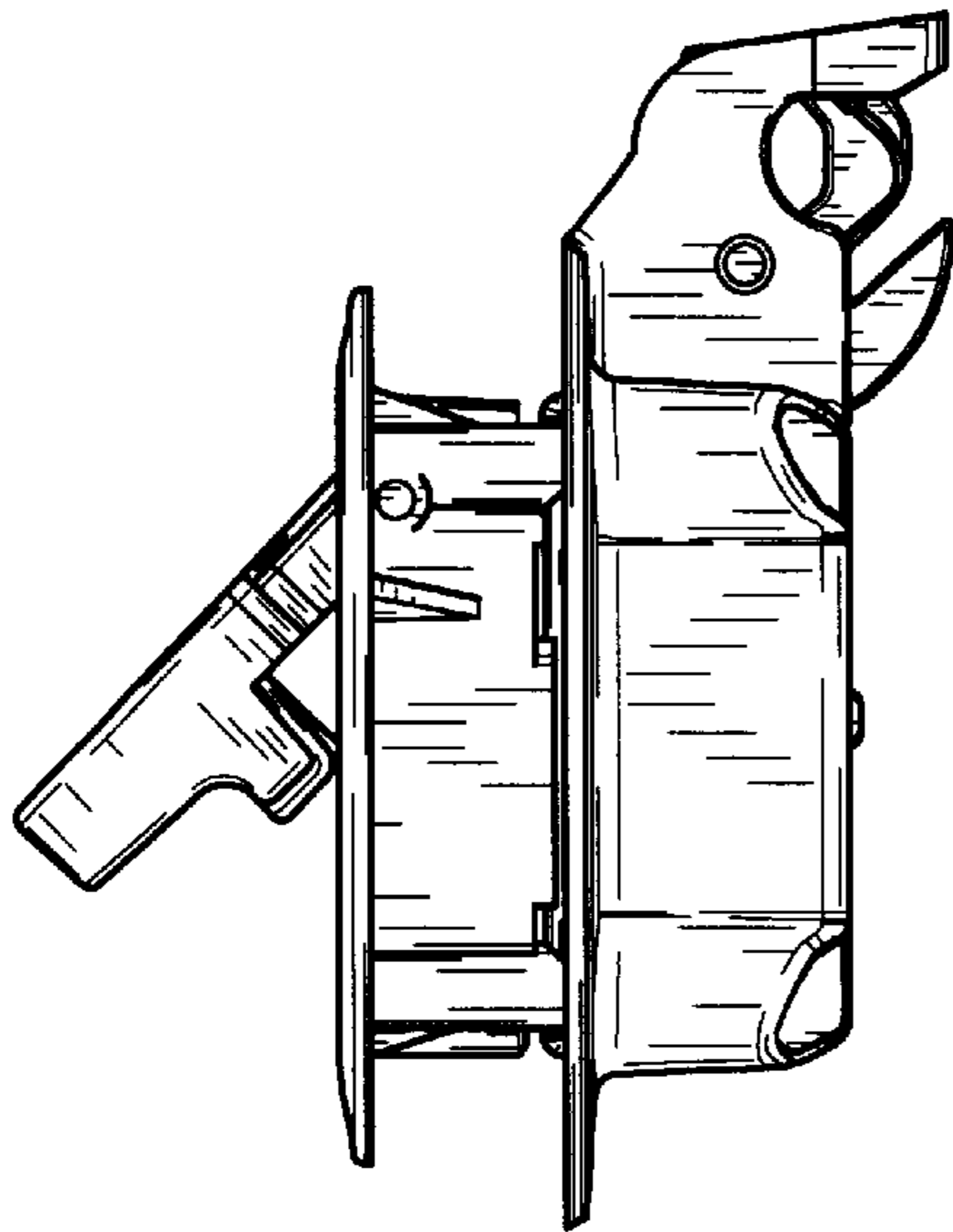

FIG. 12

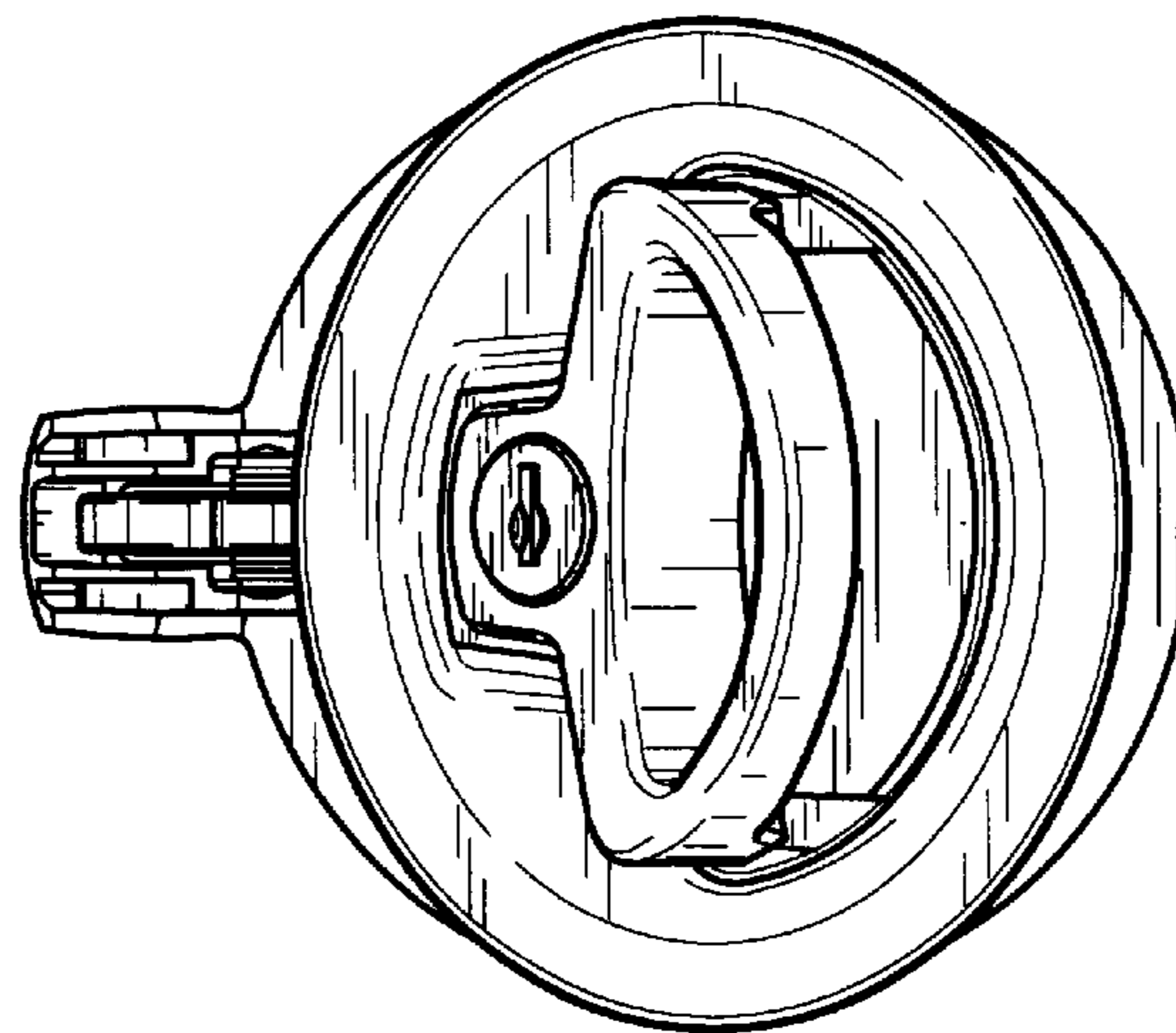

FIG. 13

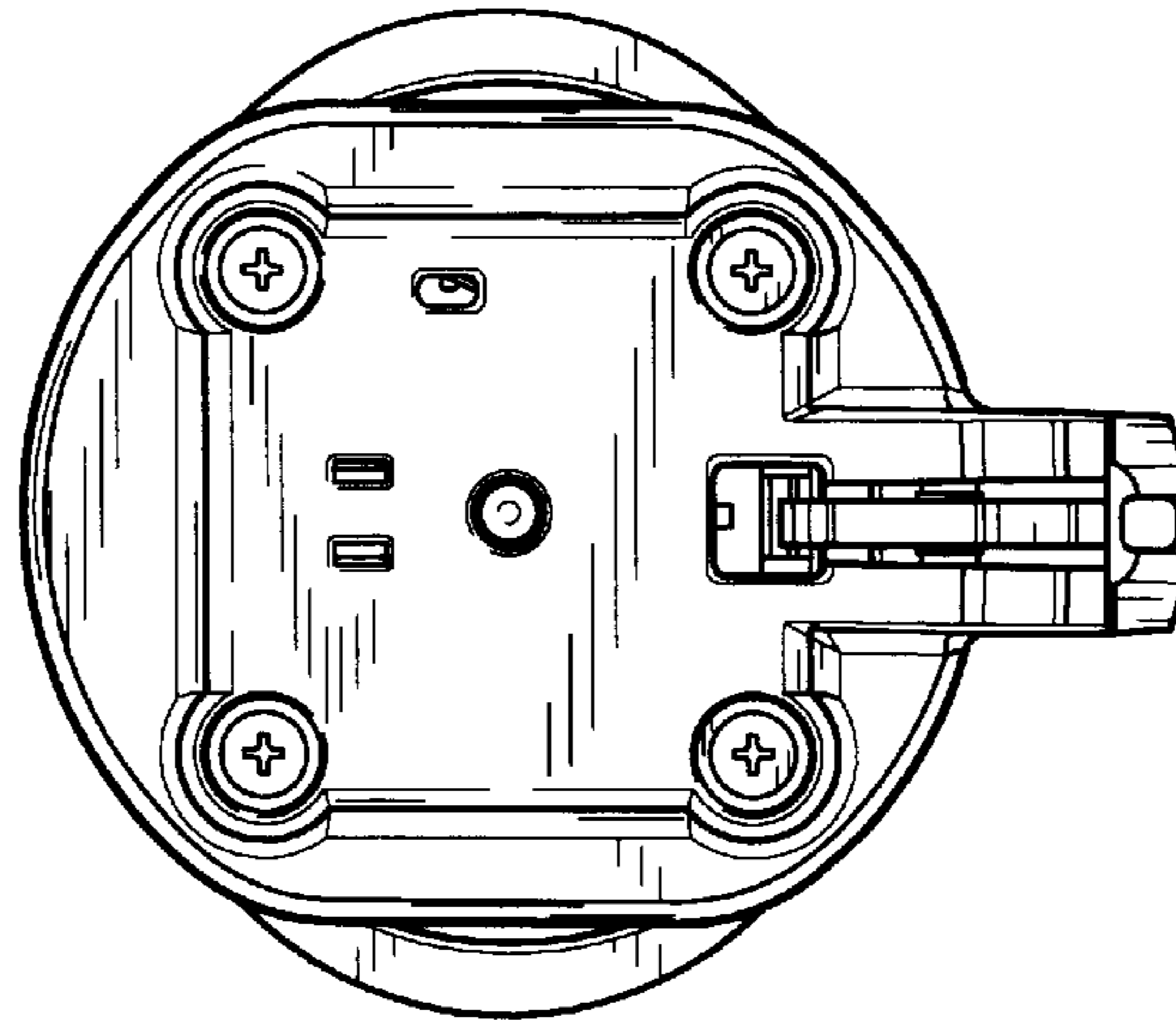
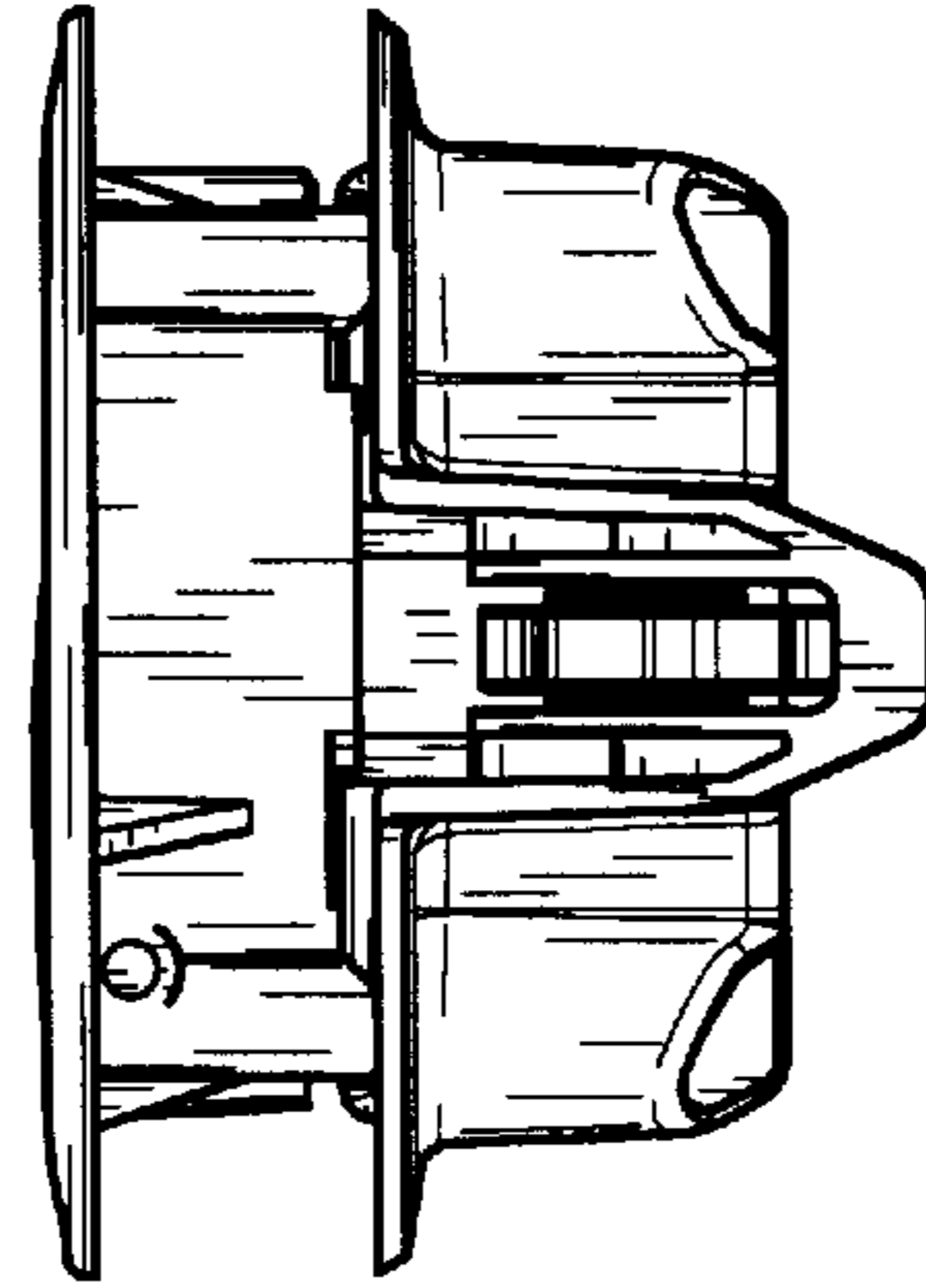
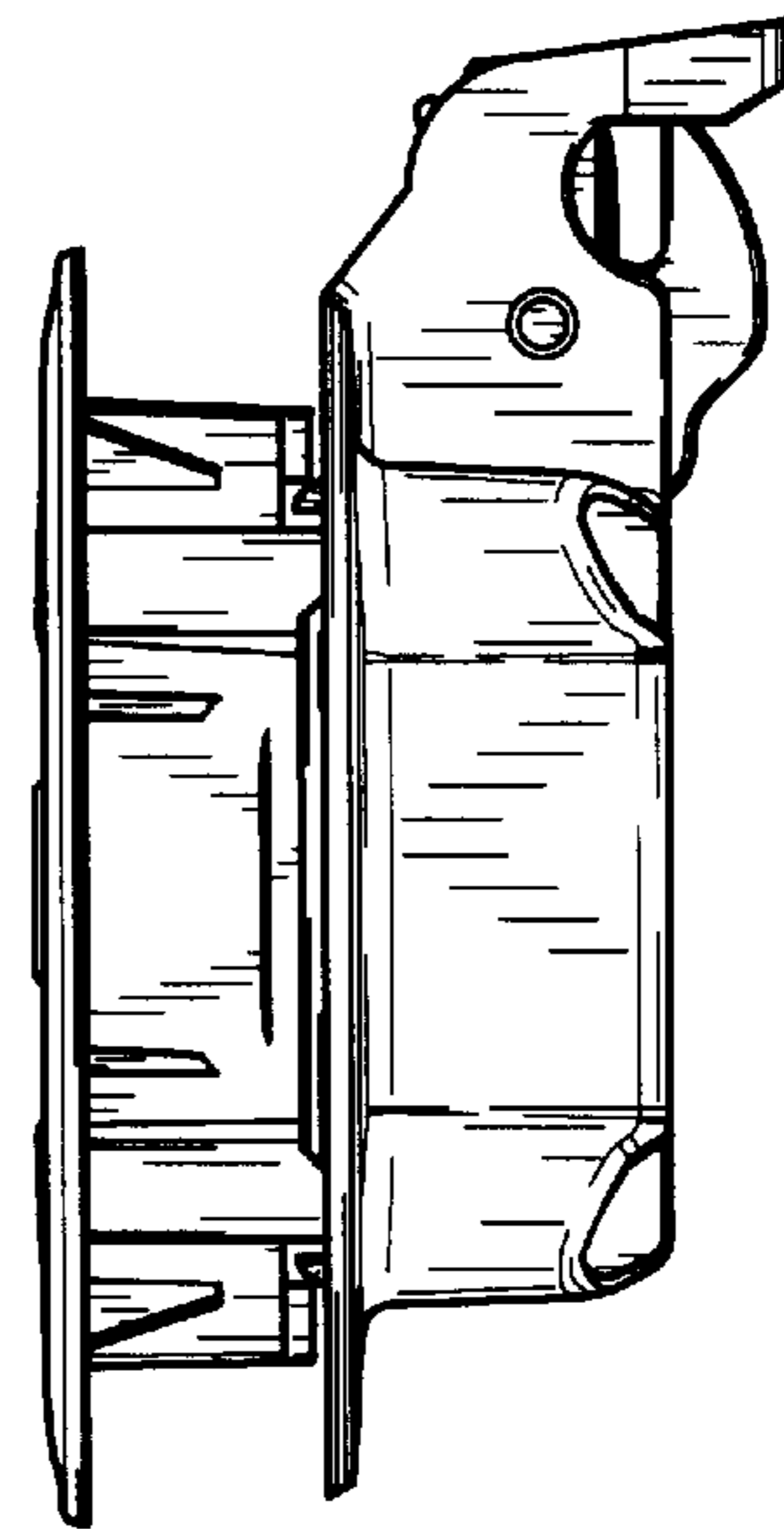
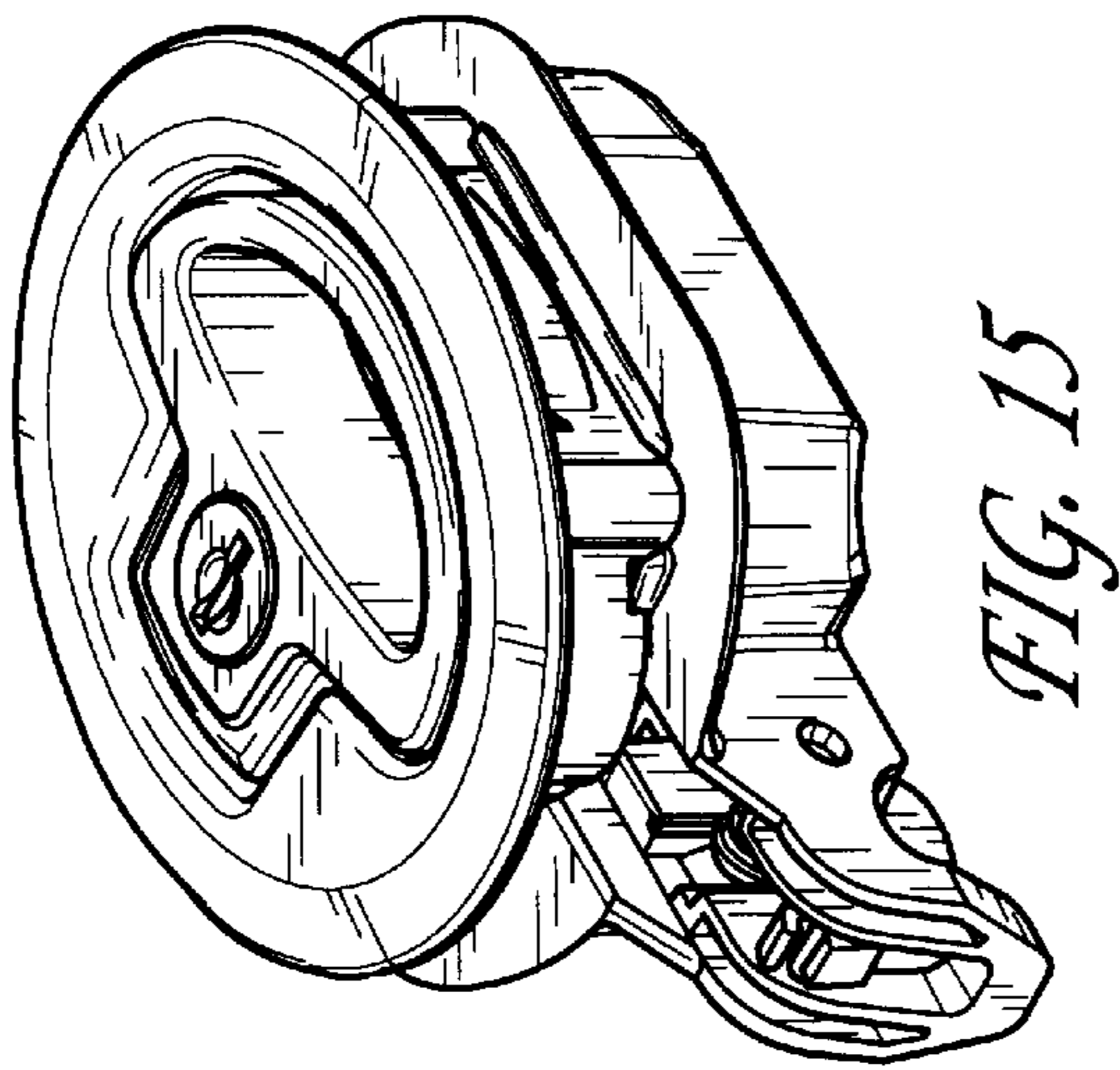

FIG. 14



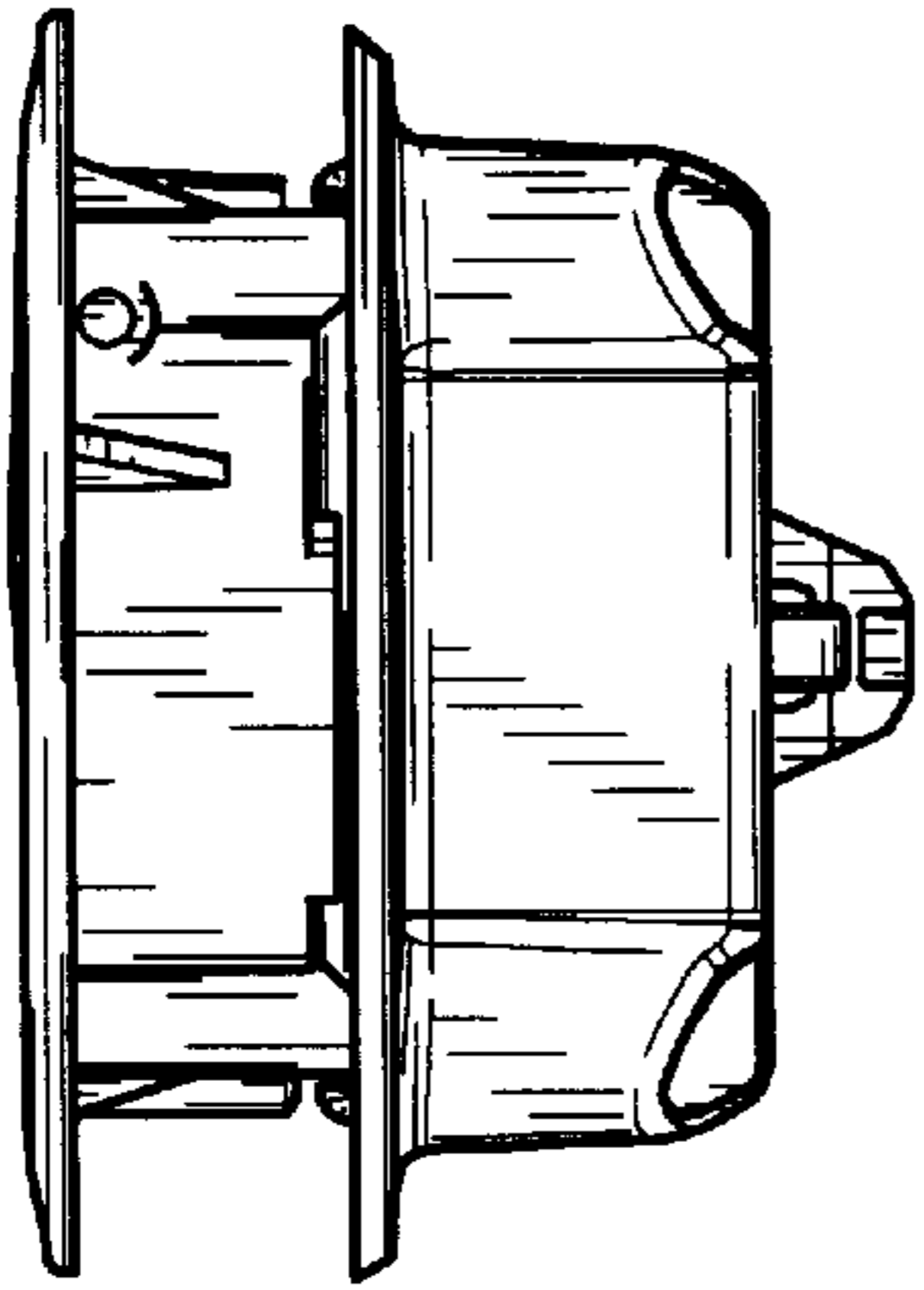

FIG. 19

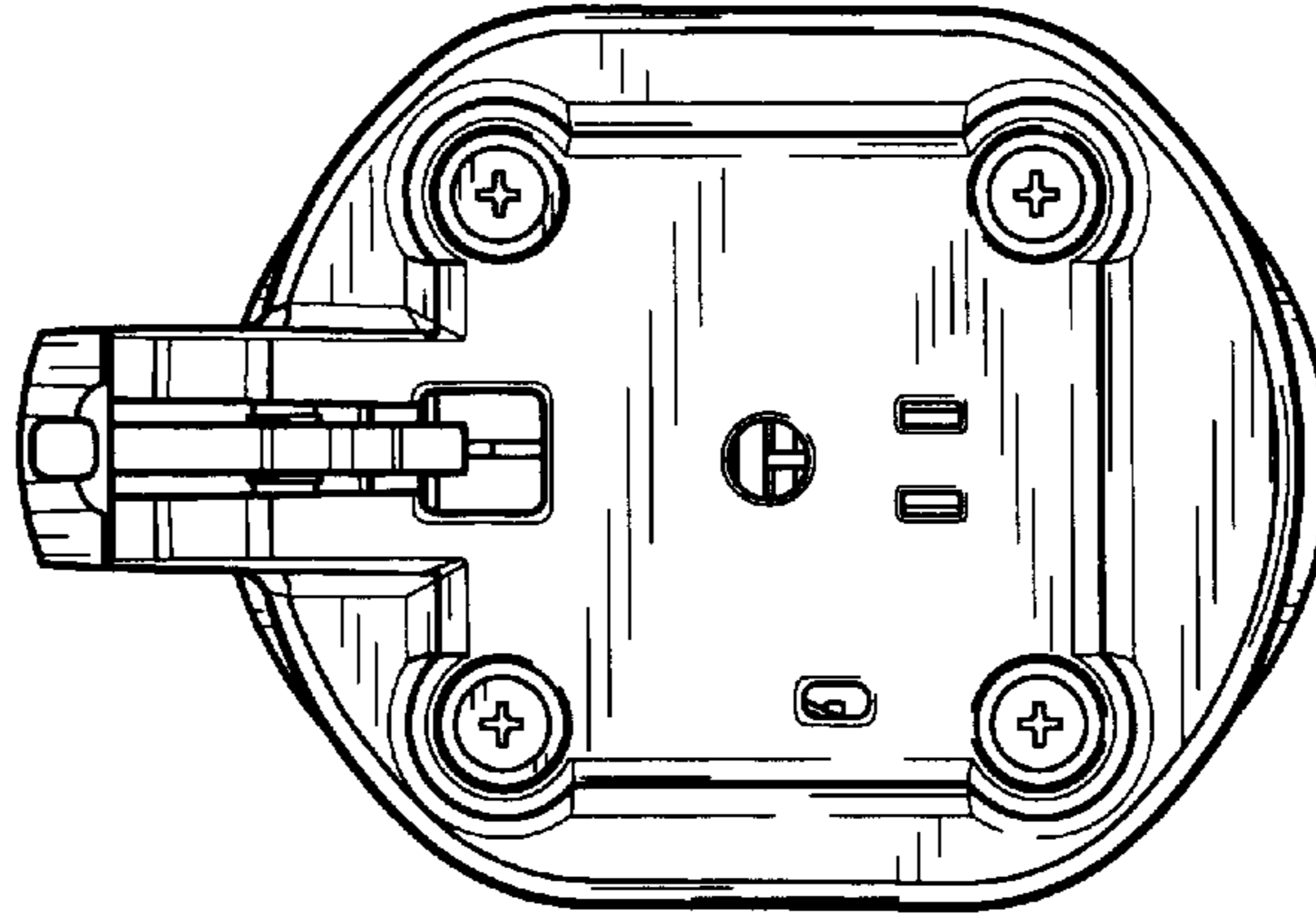

FIG. 21

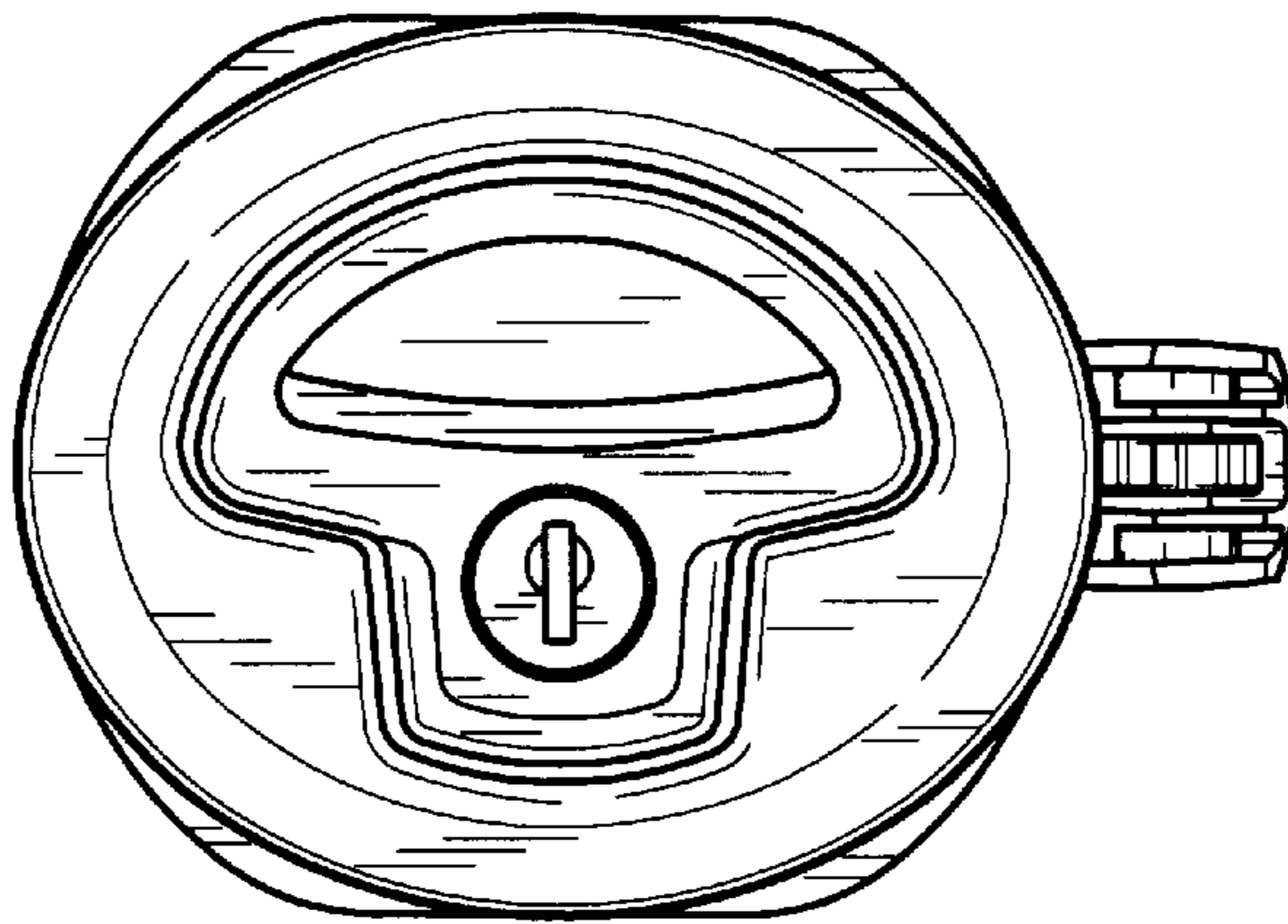

FIG. 20

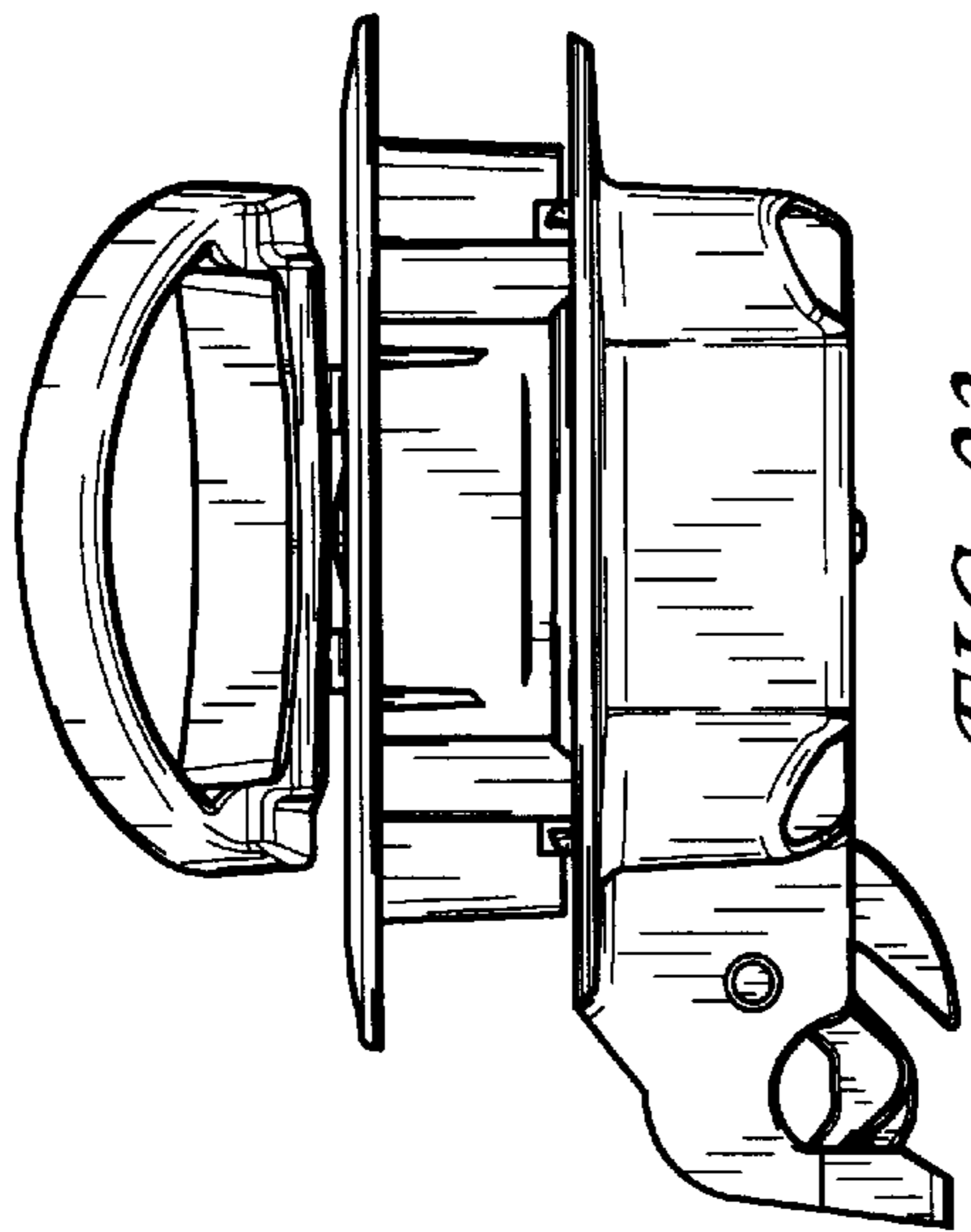

FIG. 23

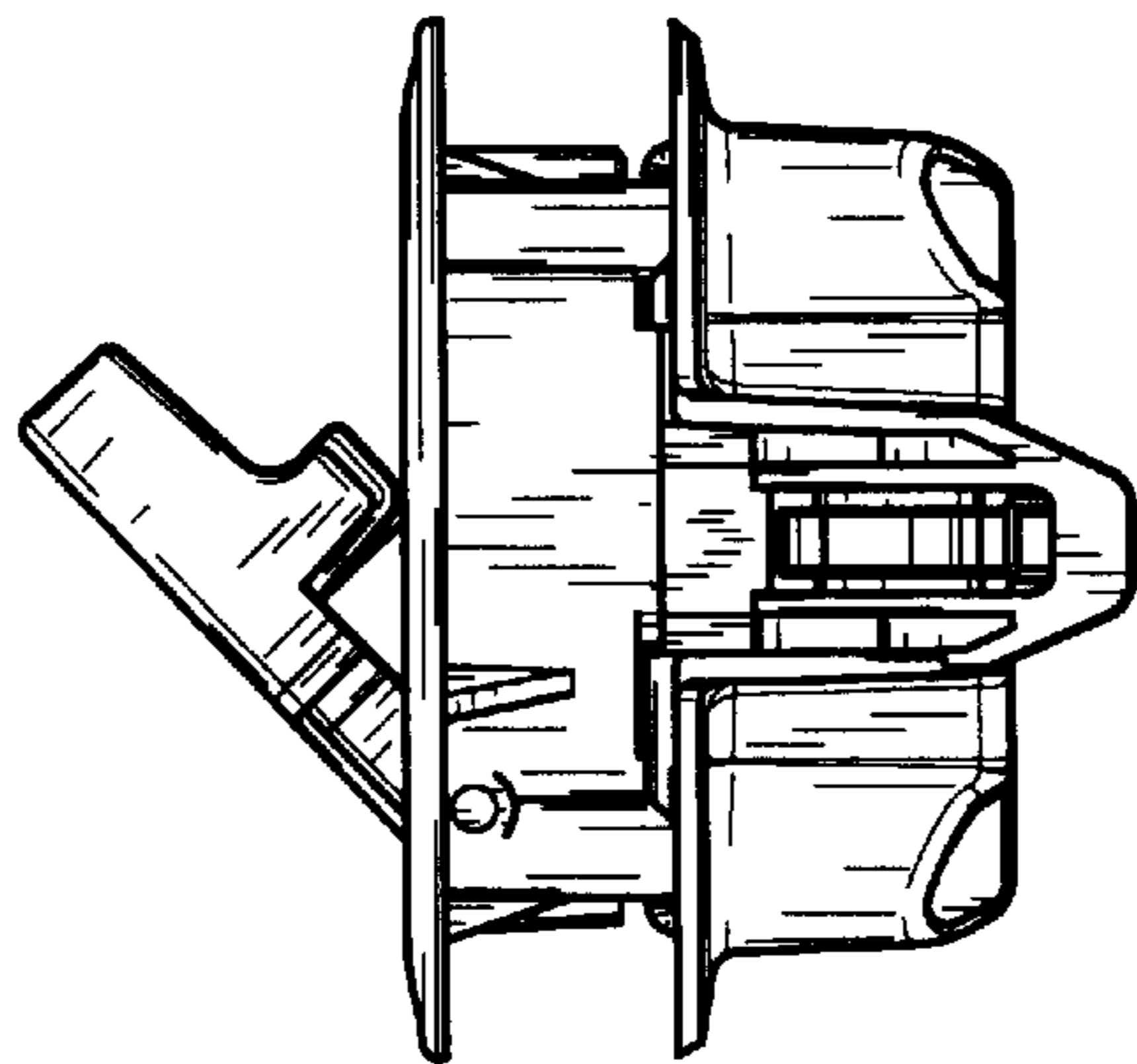

FIG. 25

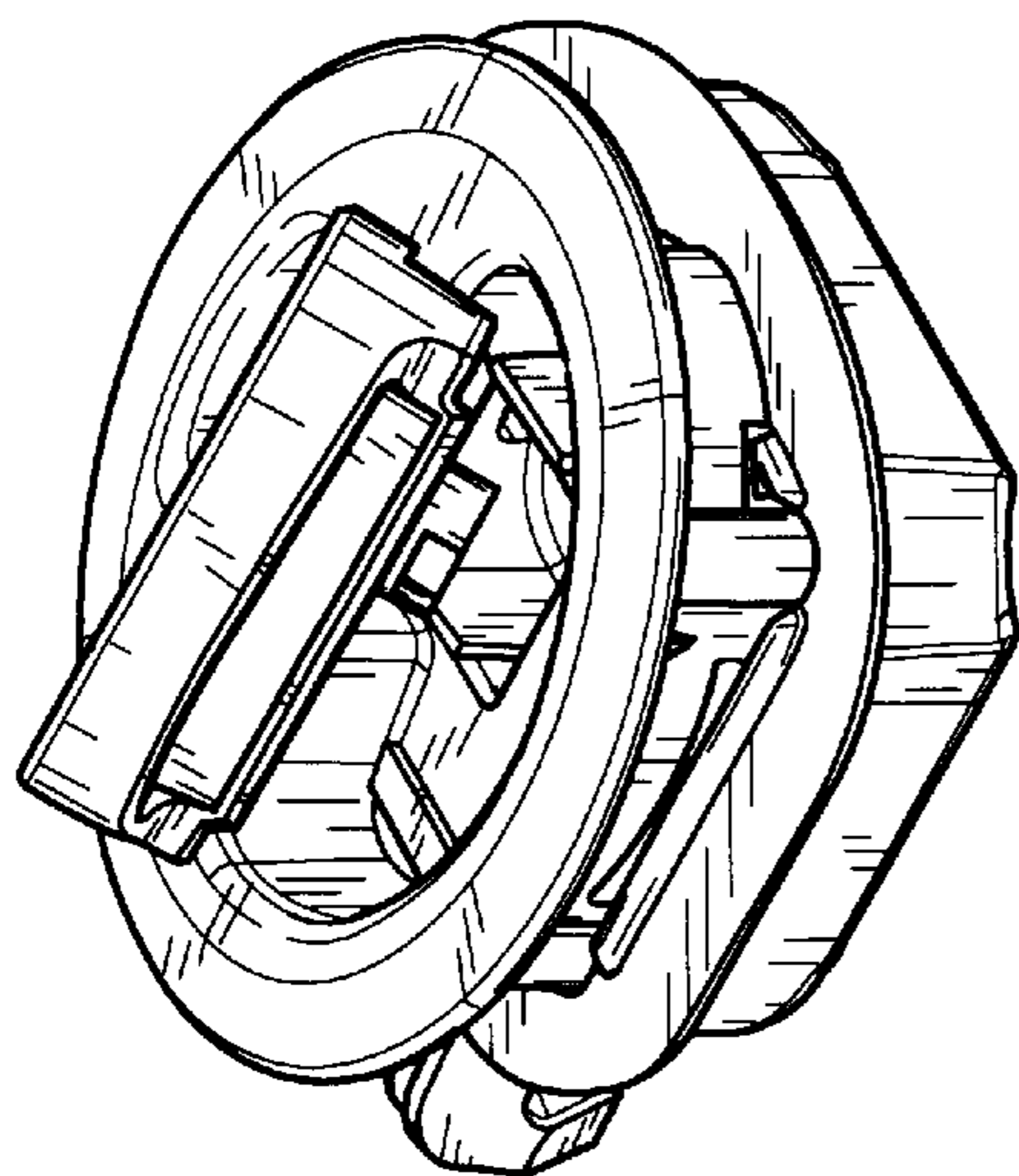

FIG. 22

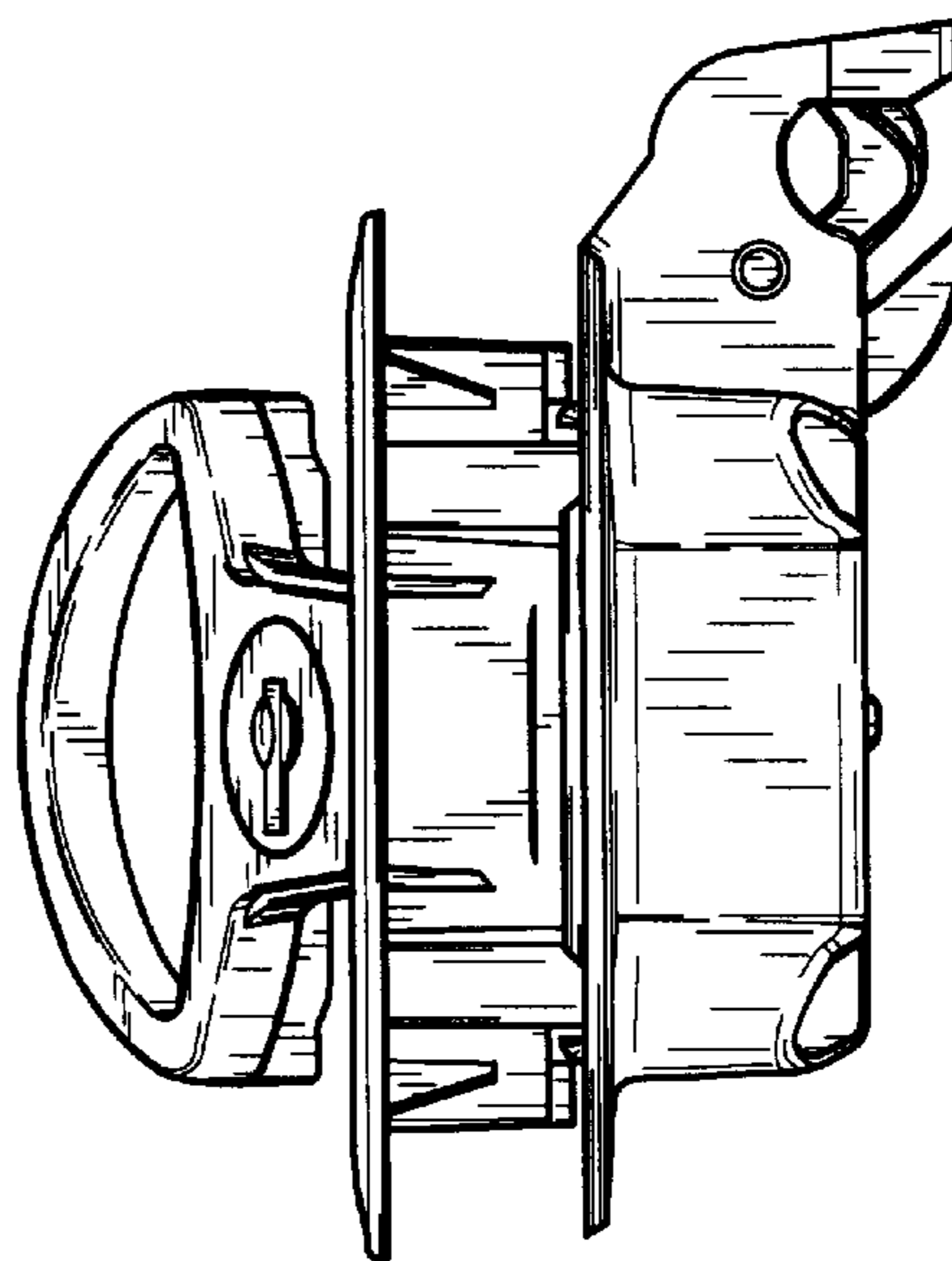

FIG. 24

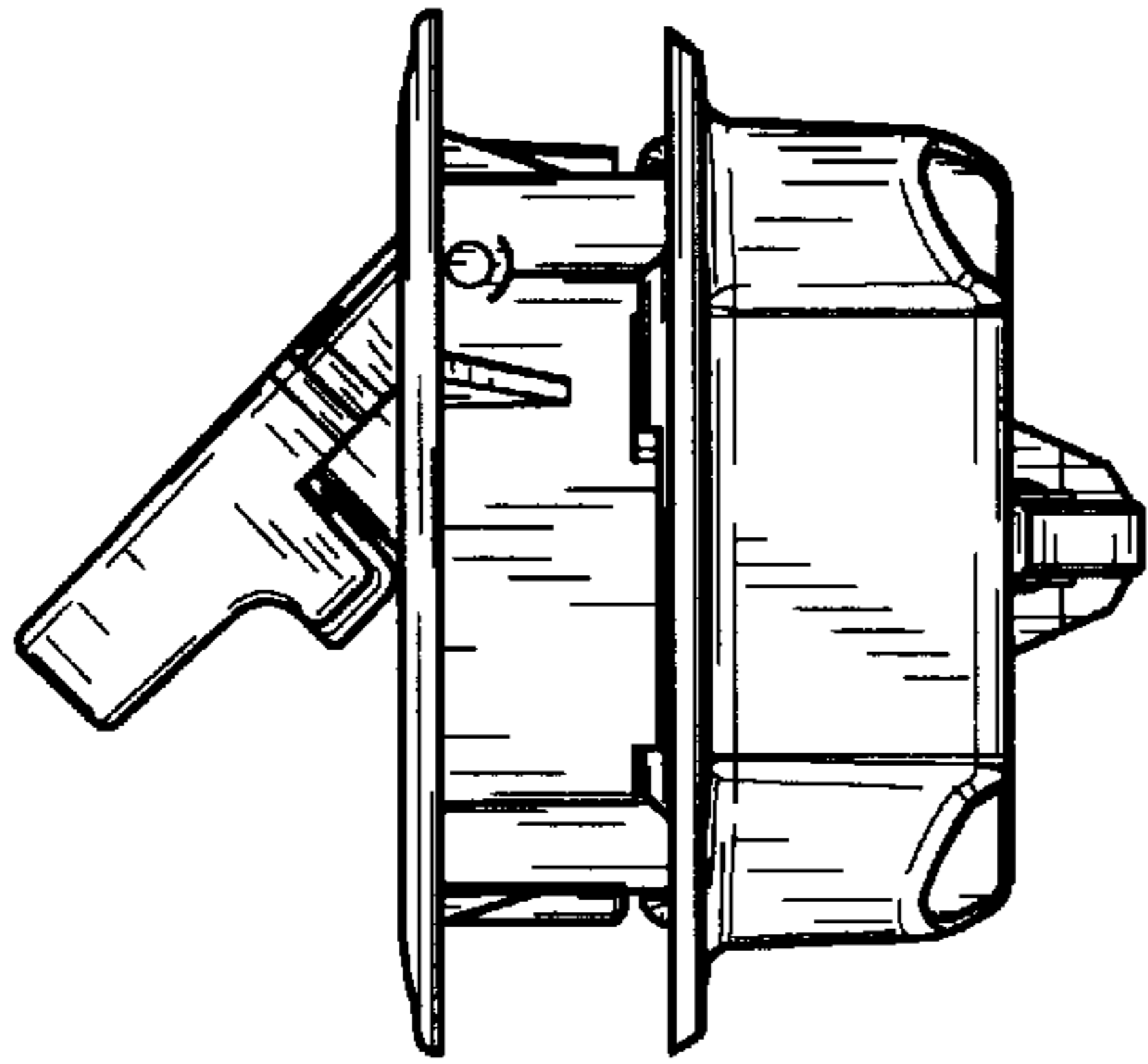

FIG. 26

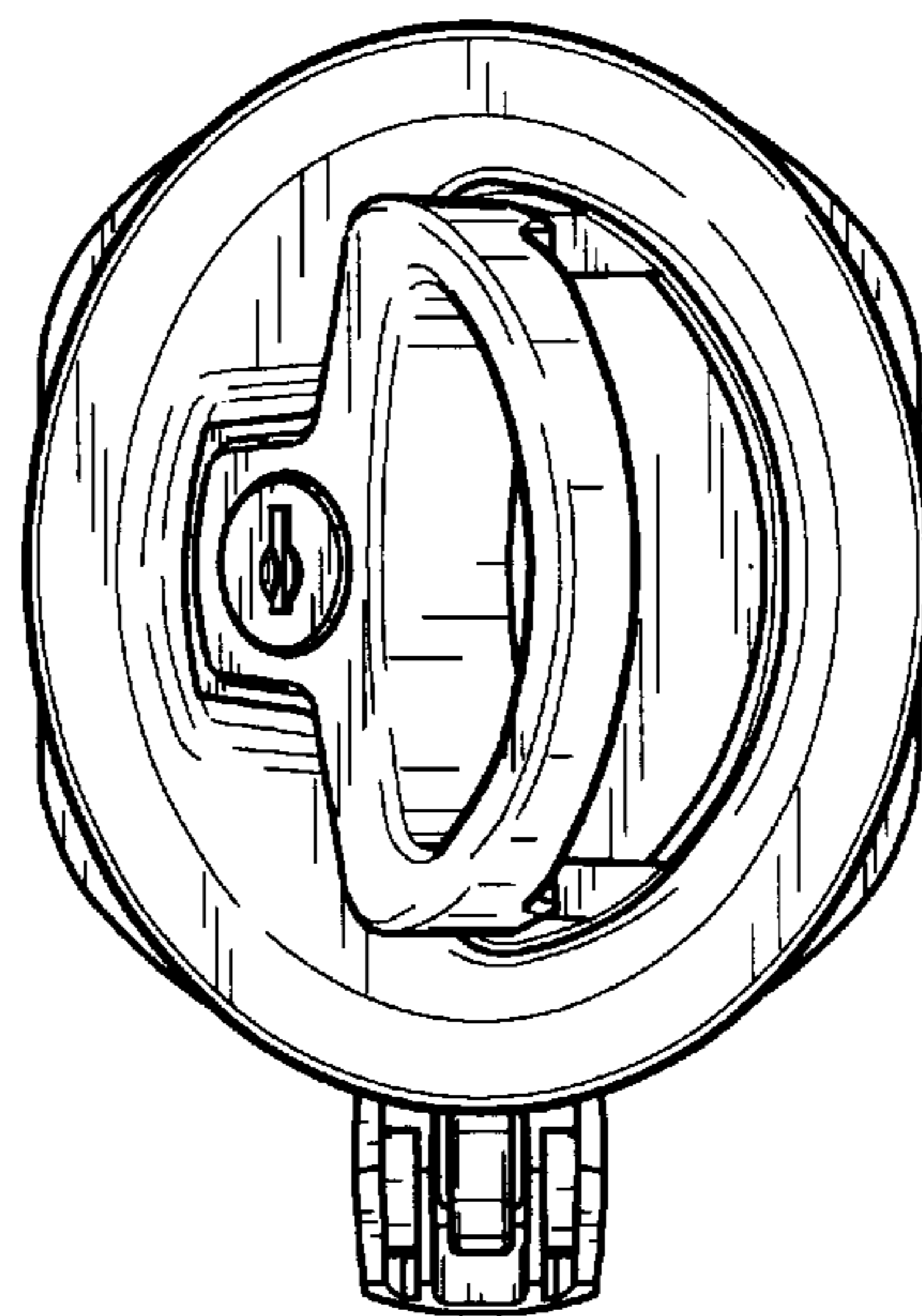

FIG. 27

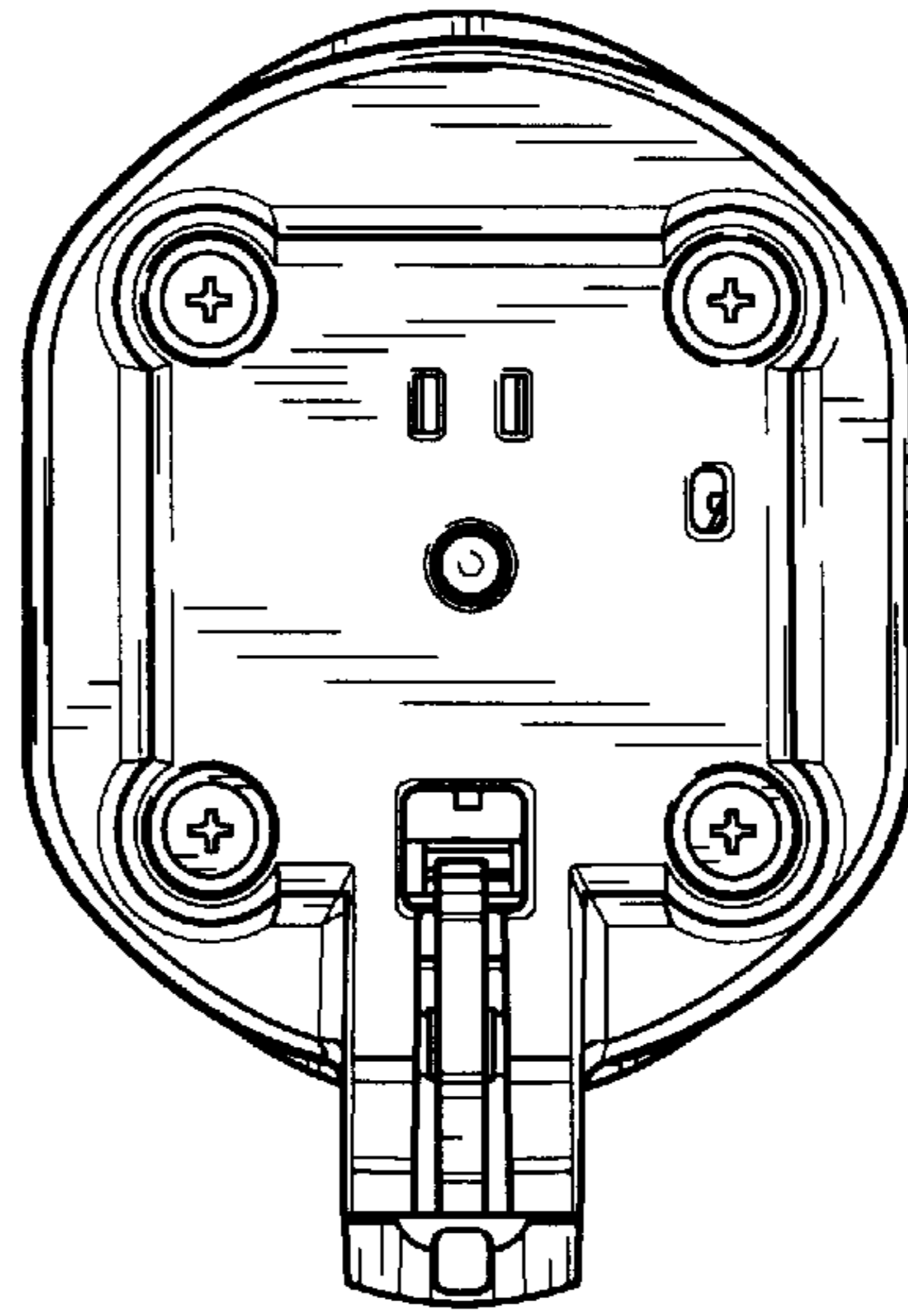

FIG. 28

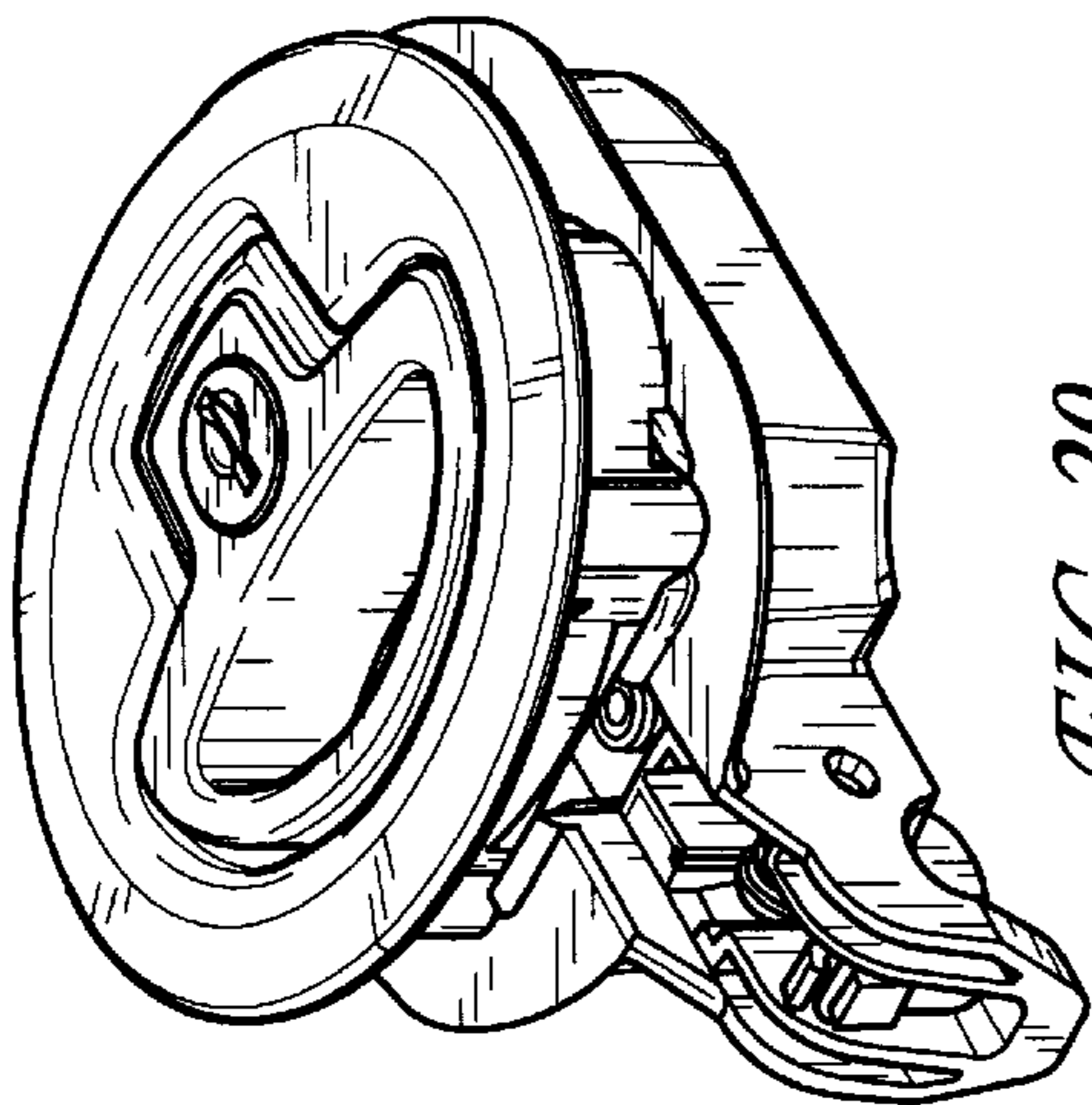

FIG. 29

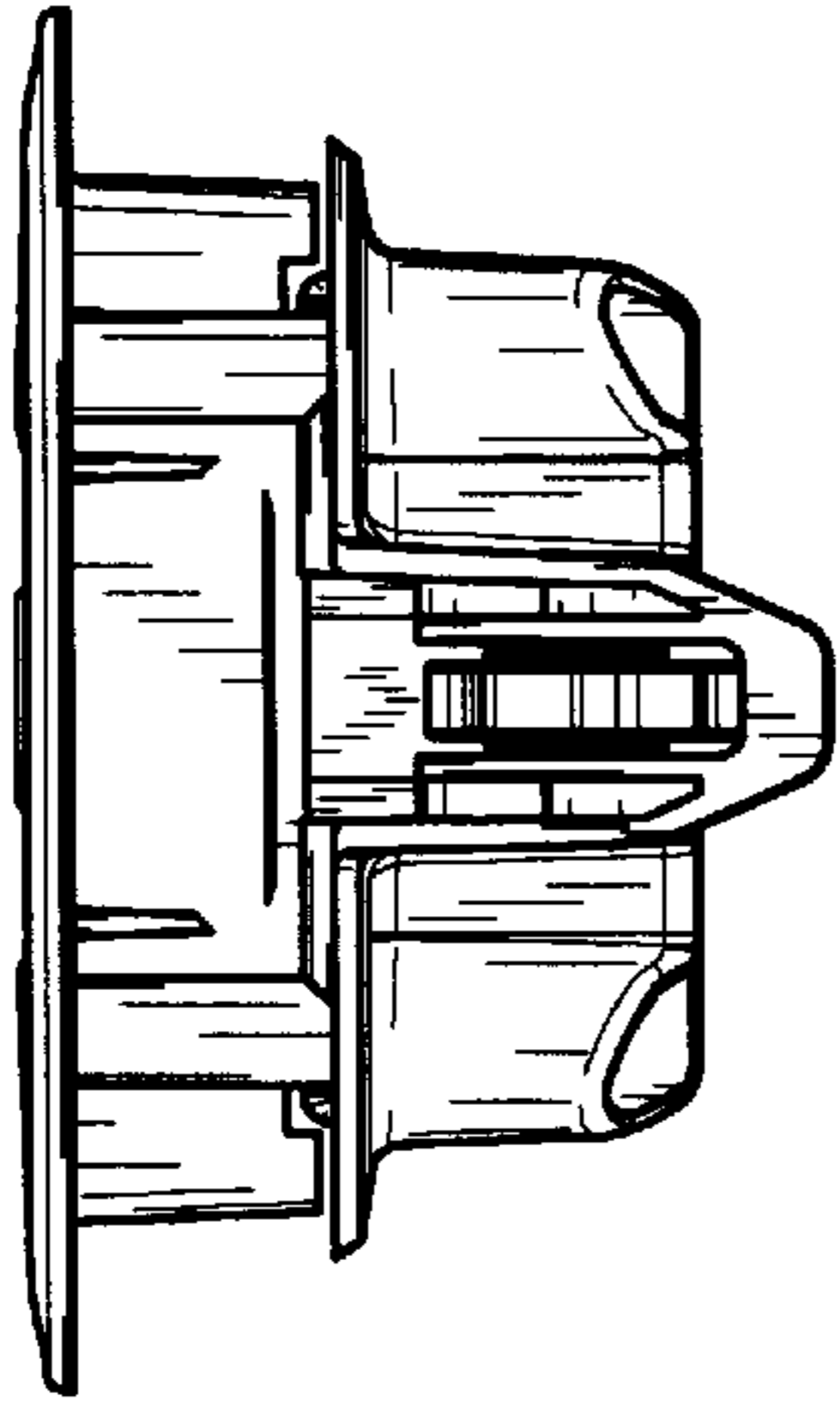

FIG. 30

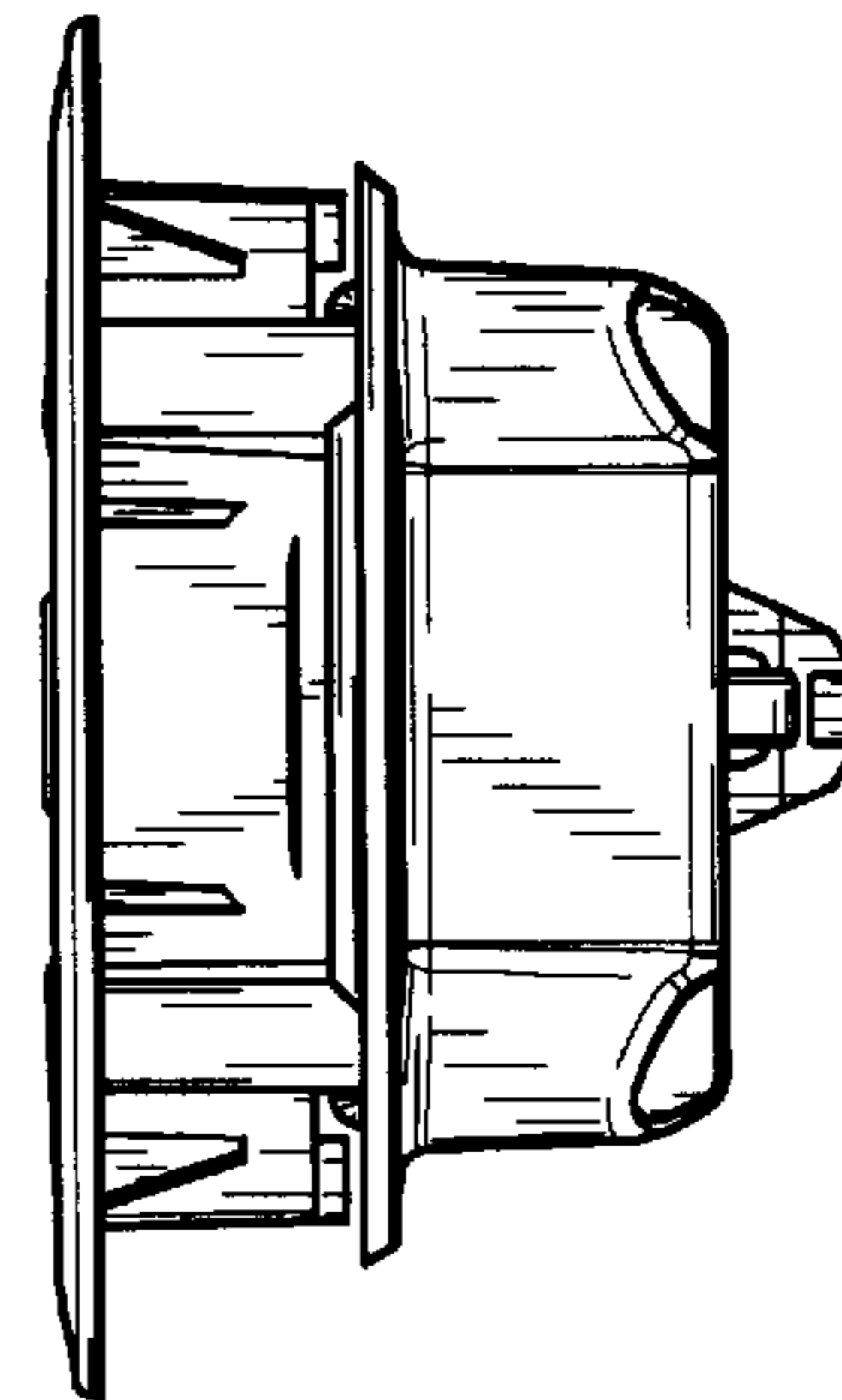

FIG. 31

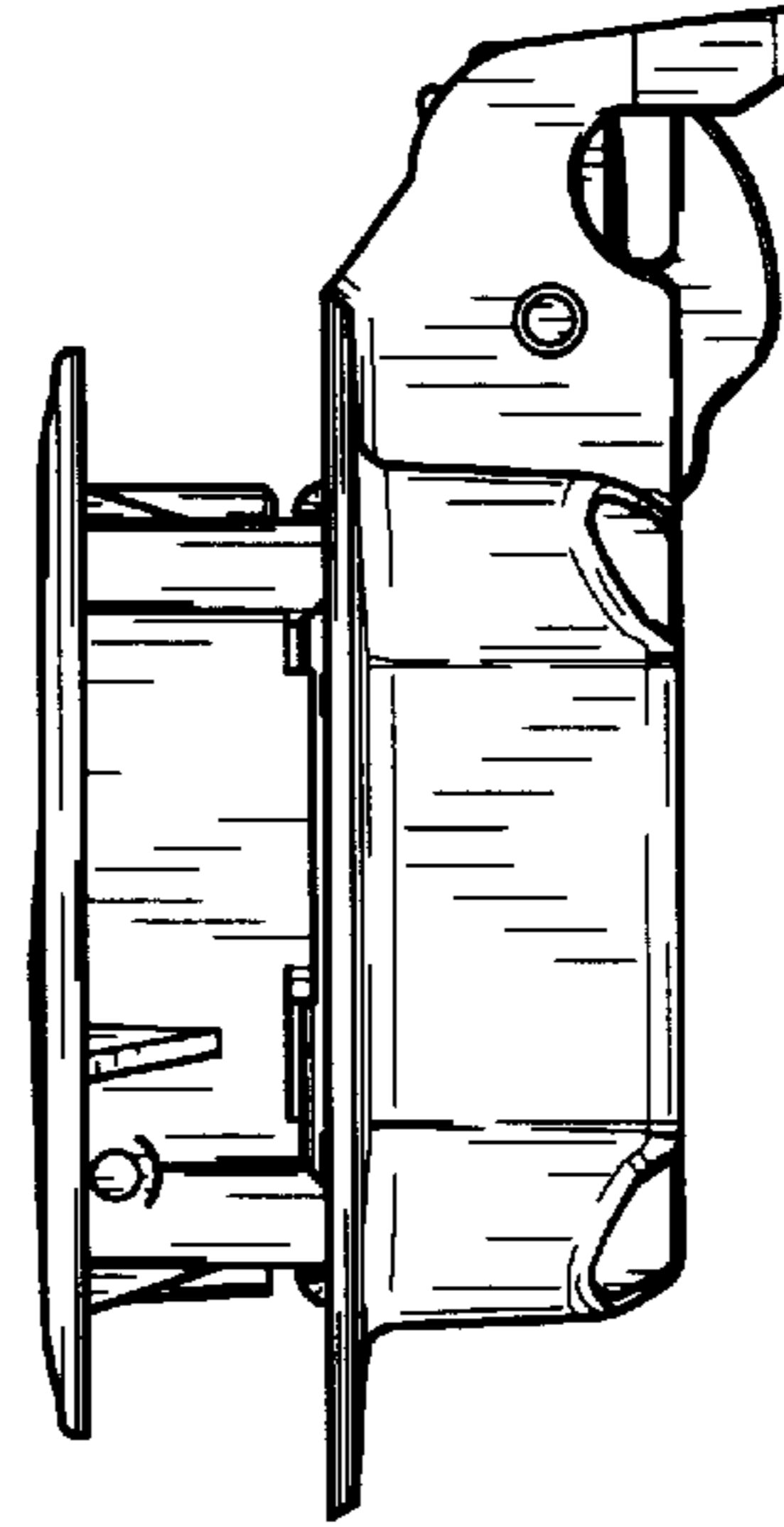

FIG. 32

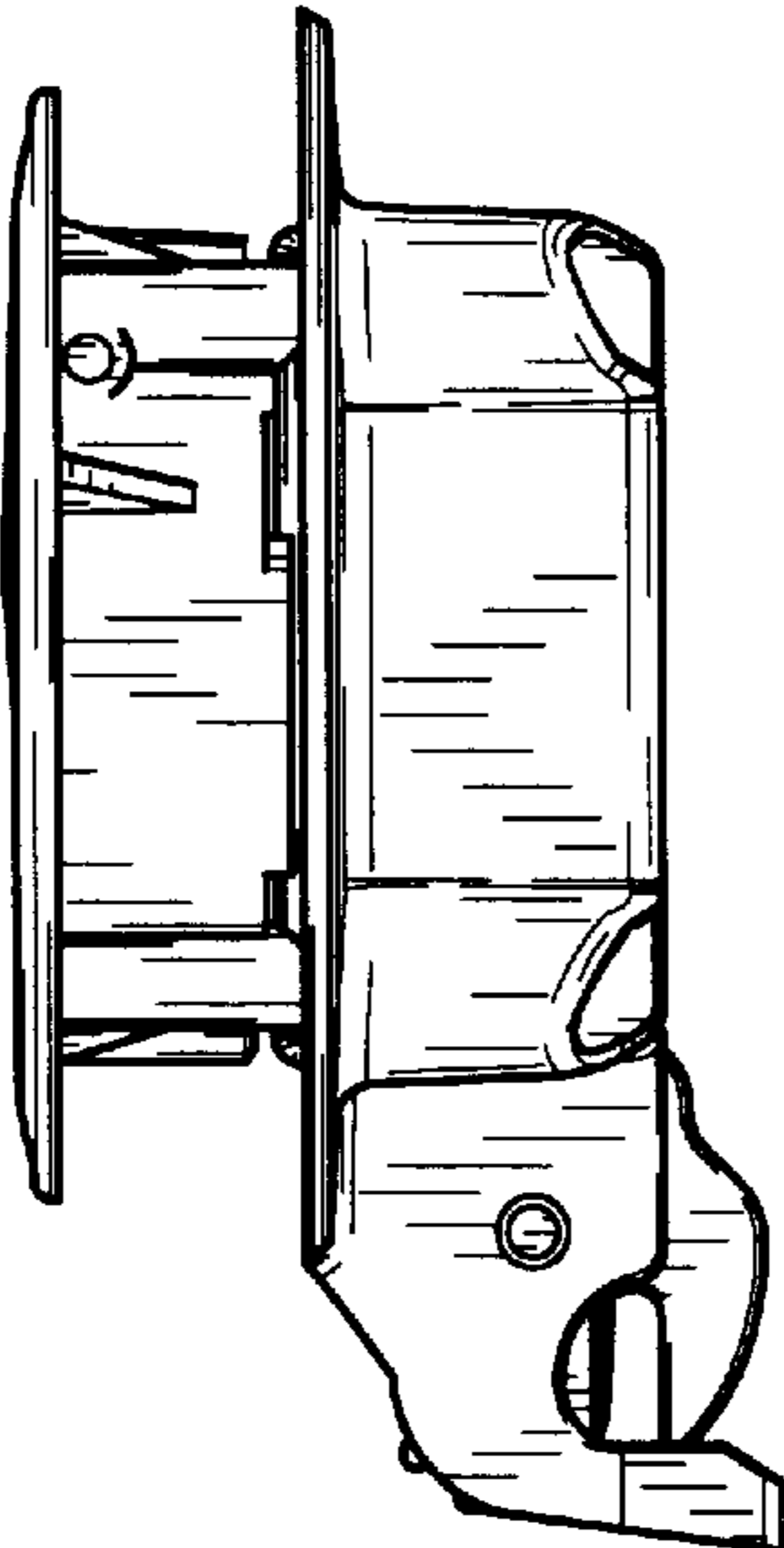

FIG. 33

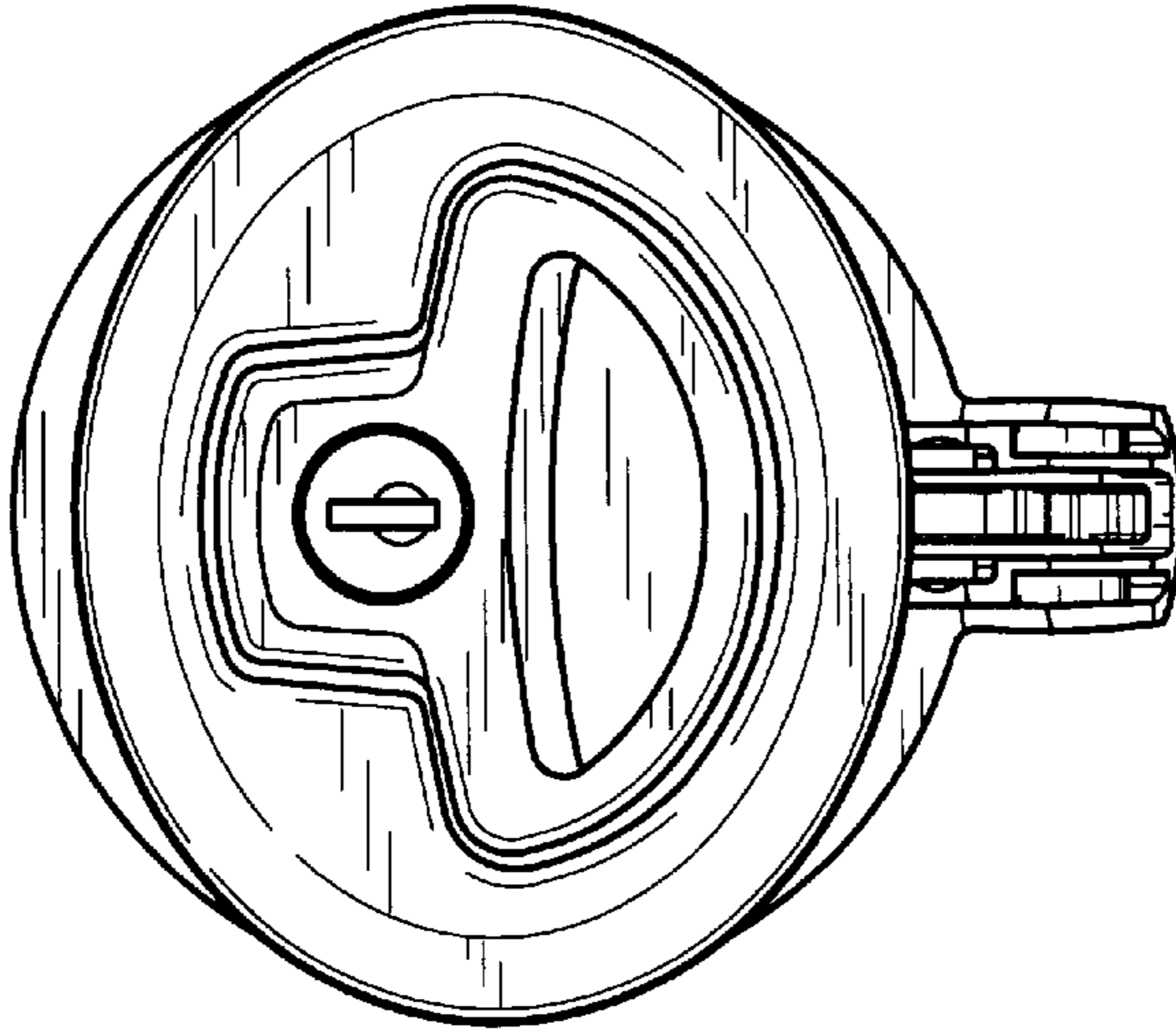

FIG. 34

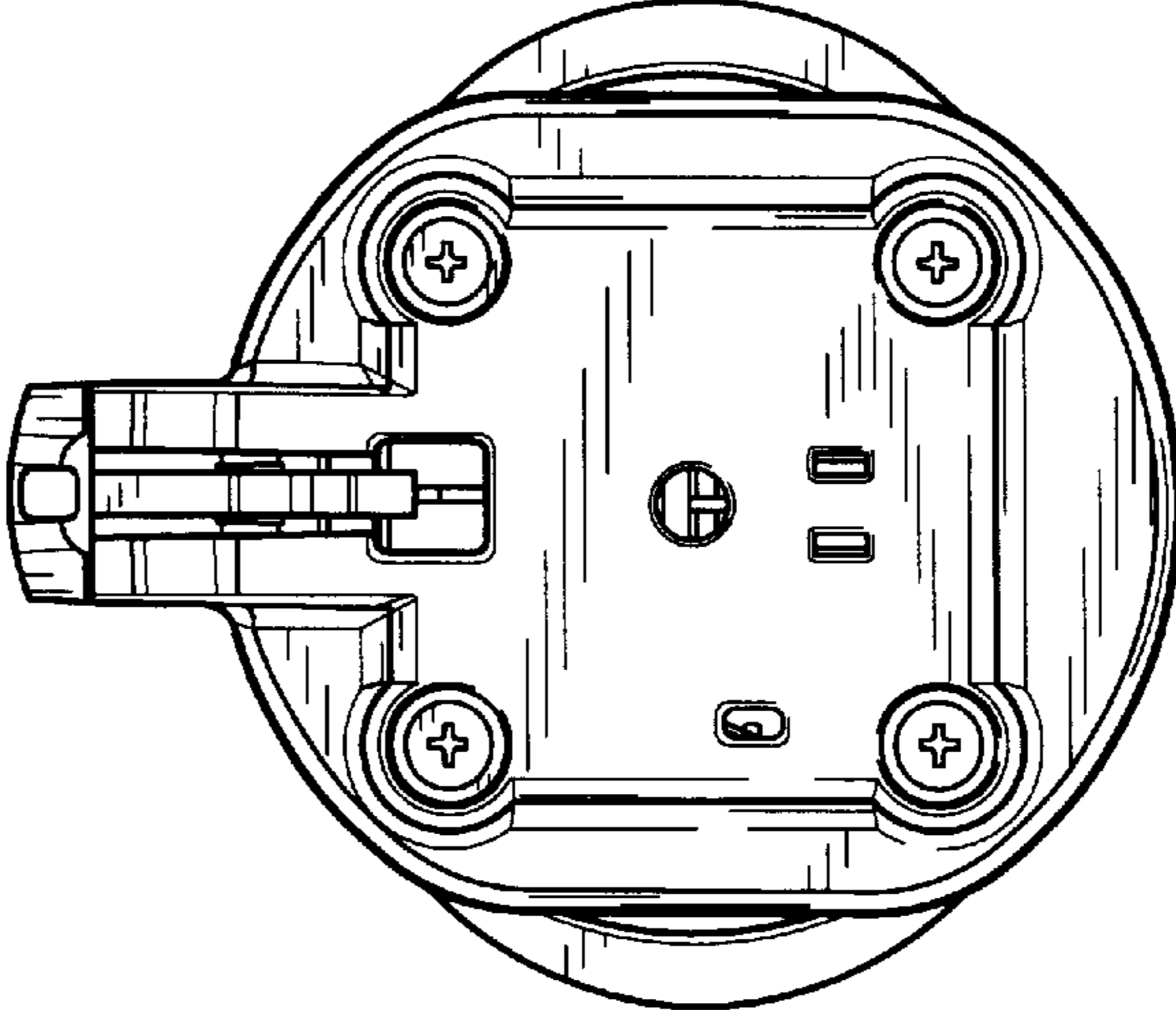

FIG. 35

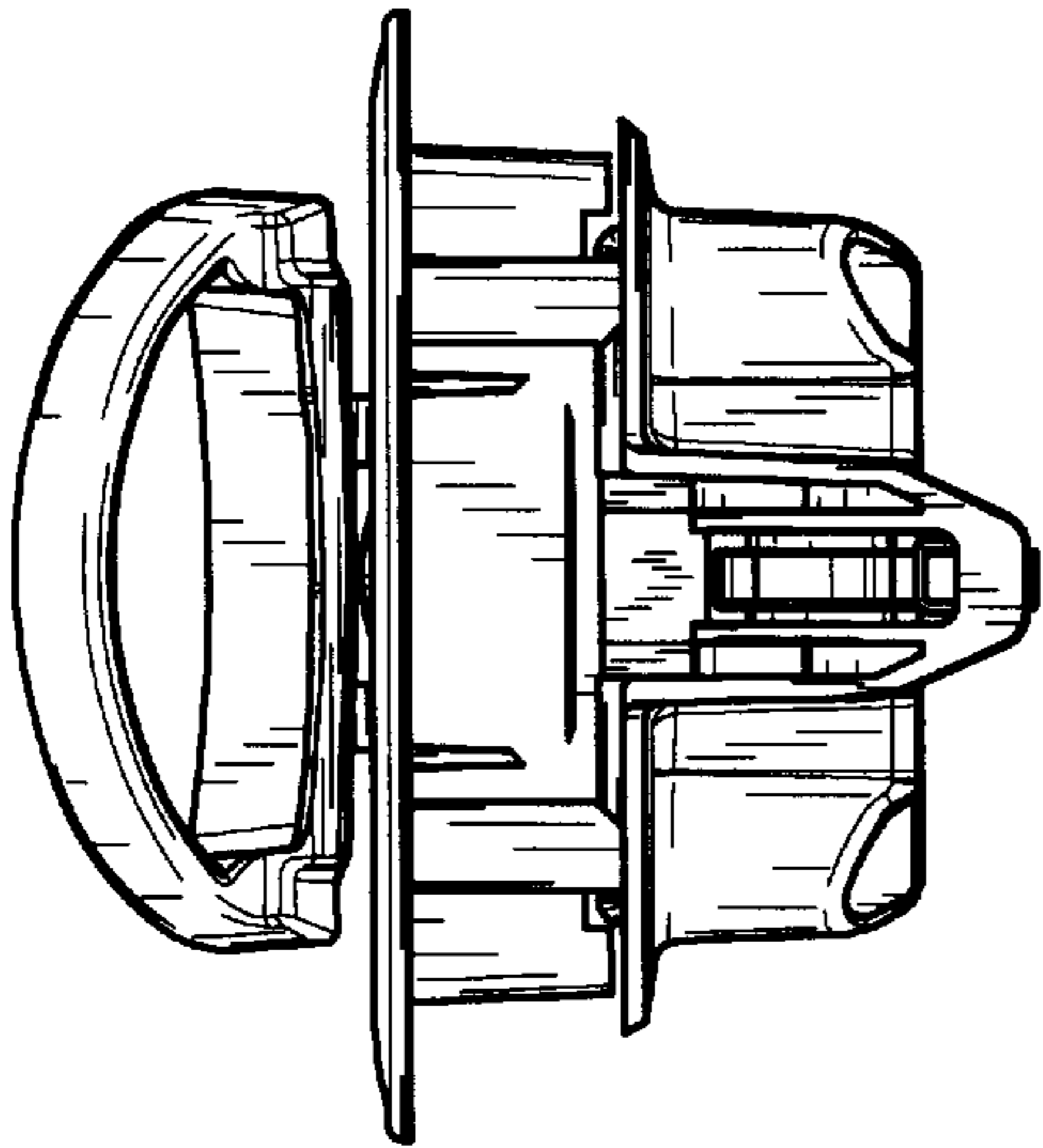

FIG. 37

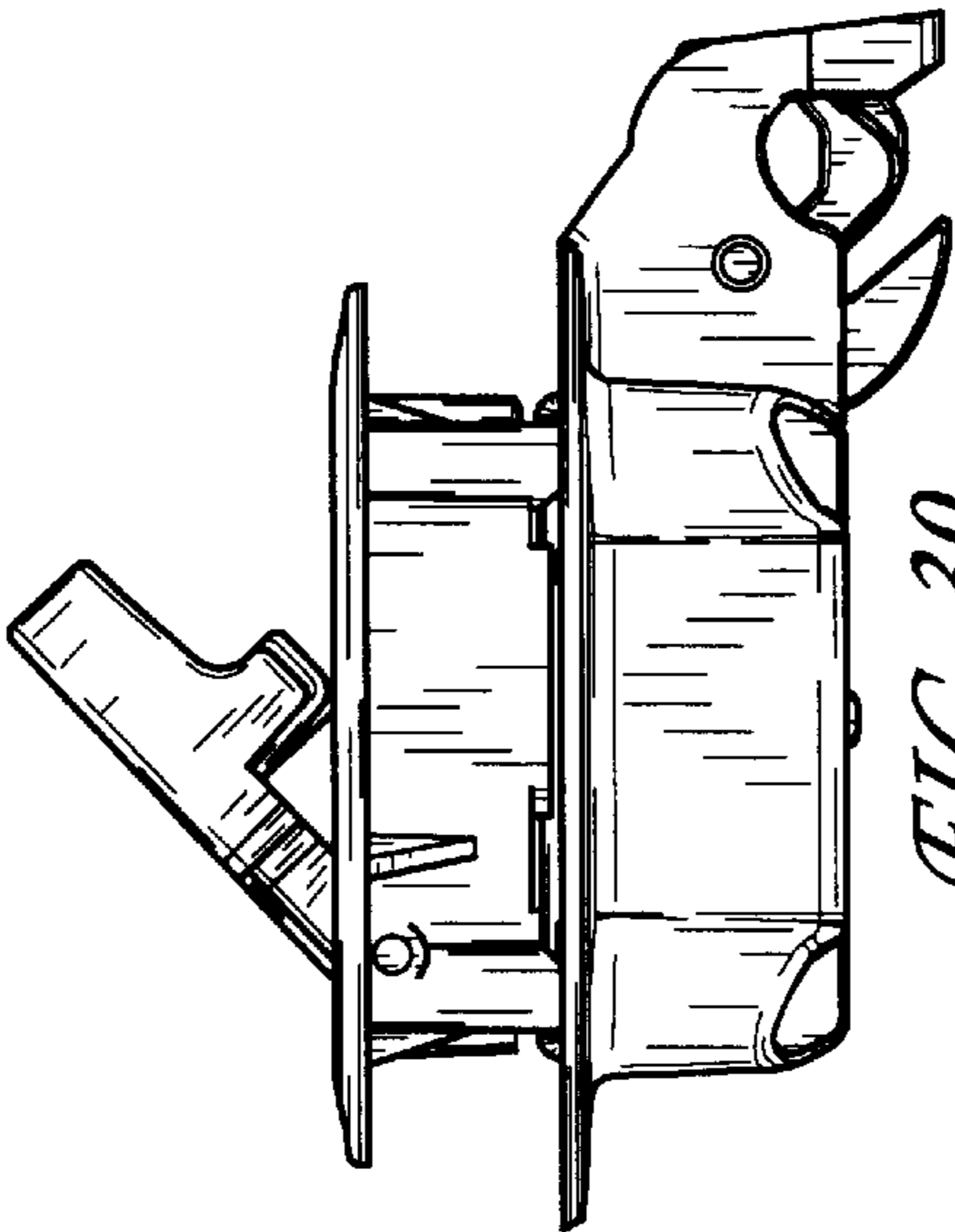

FIG. 39

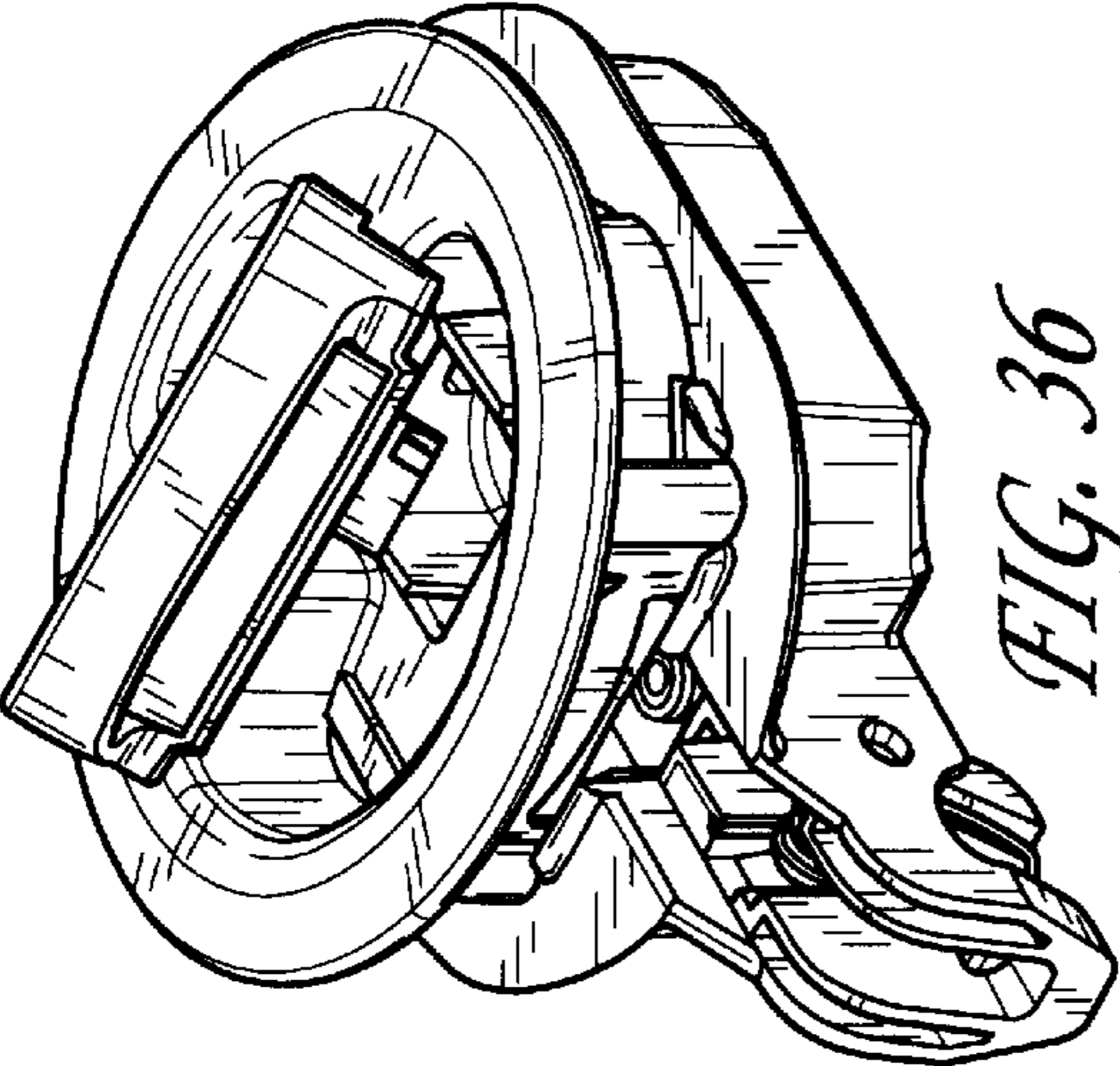

FIG. 36

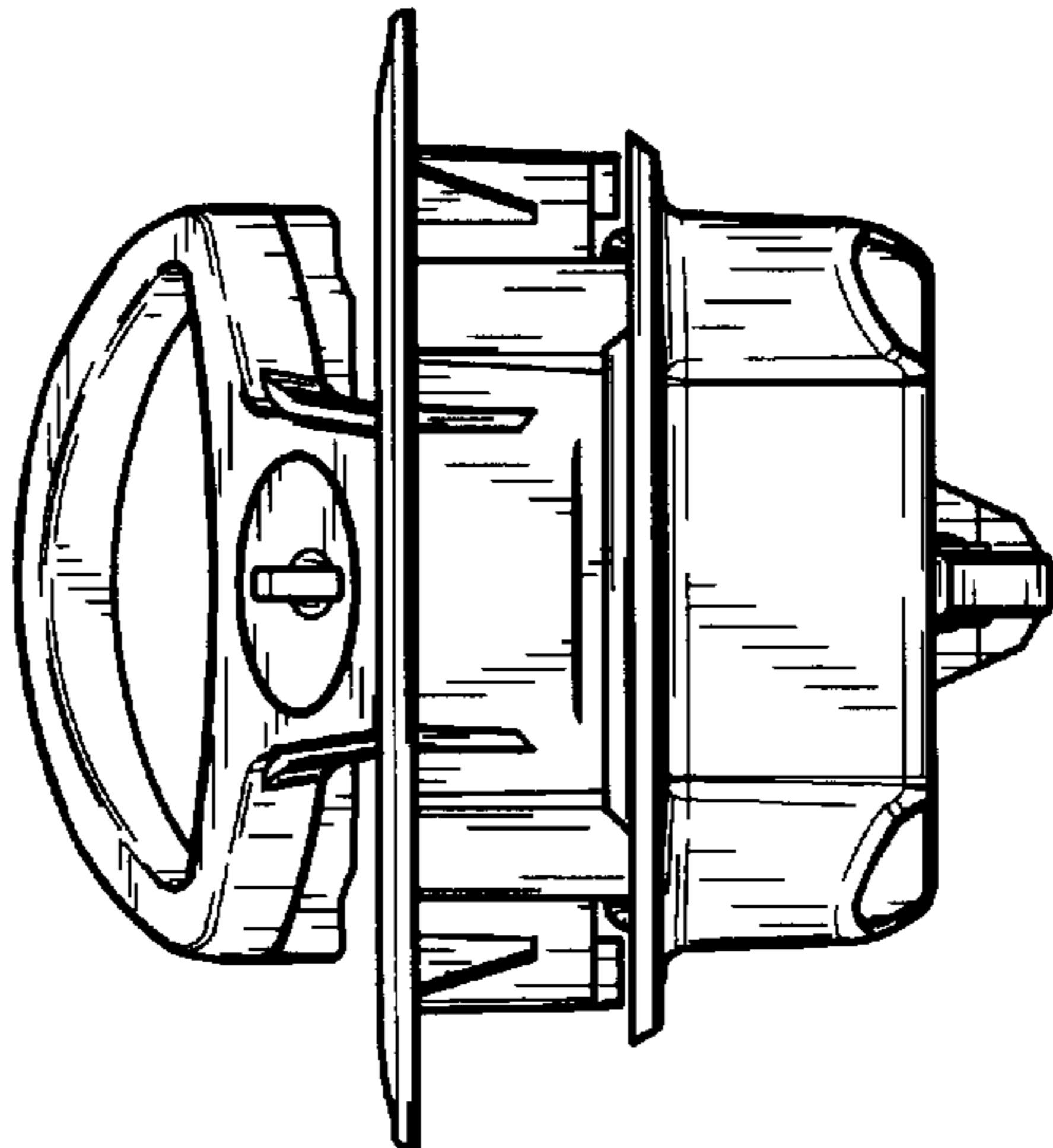

FIG. 38

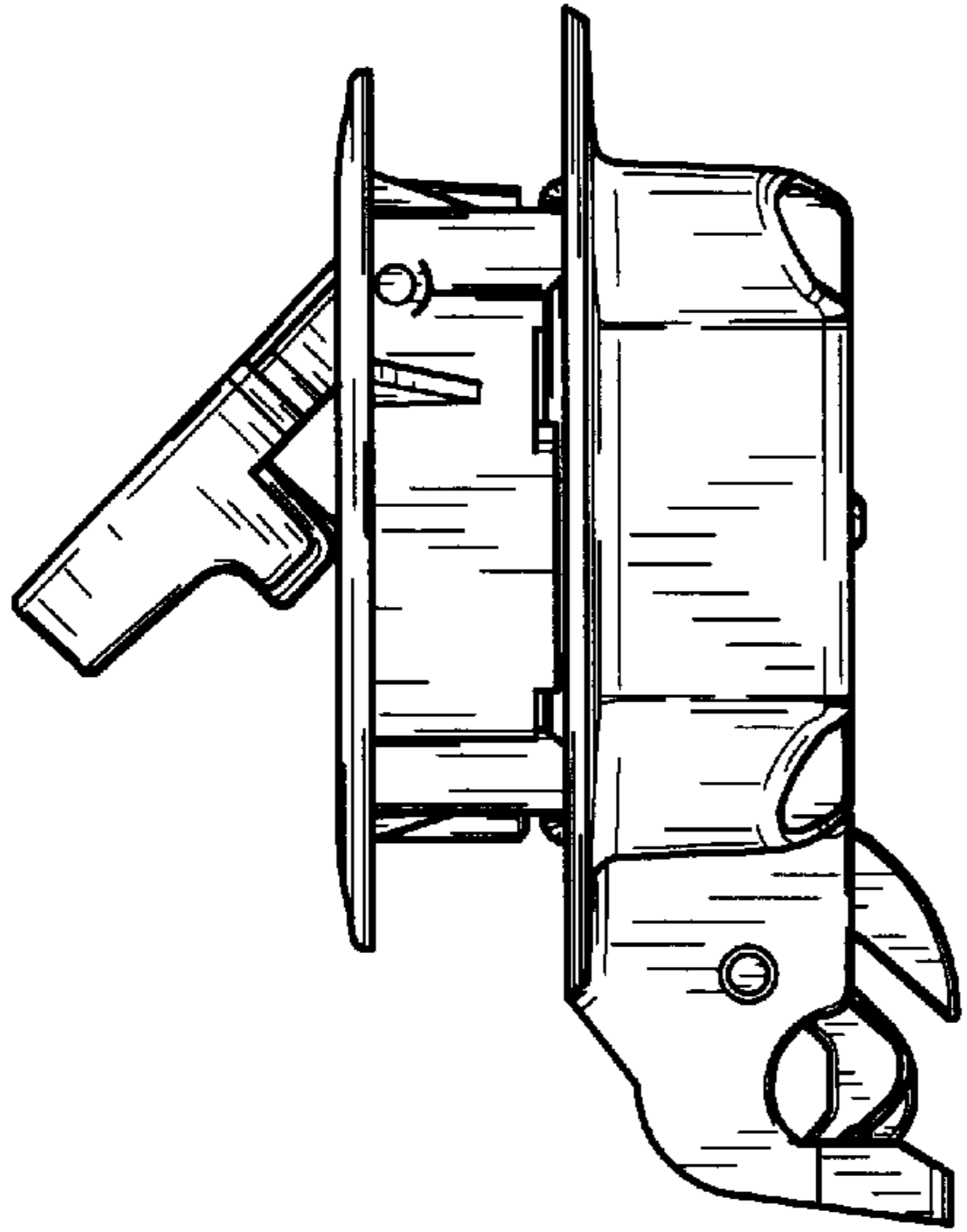

FIG. 40

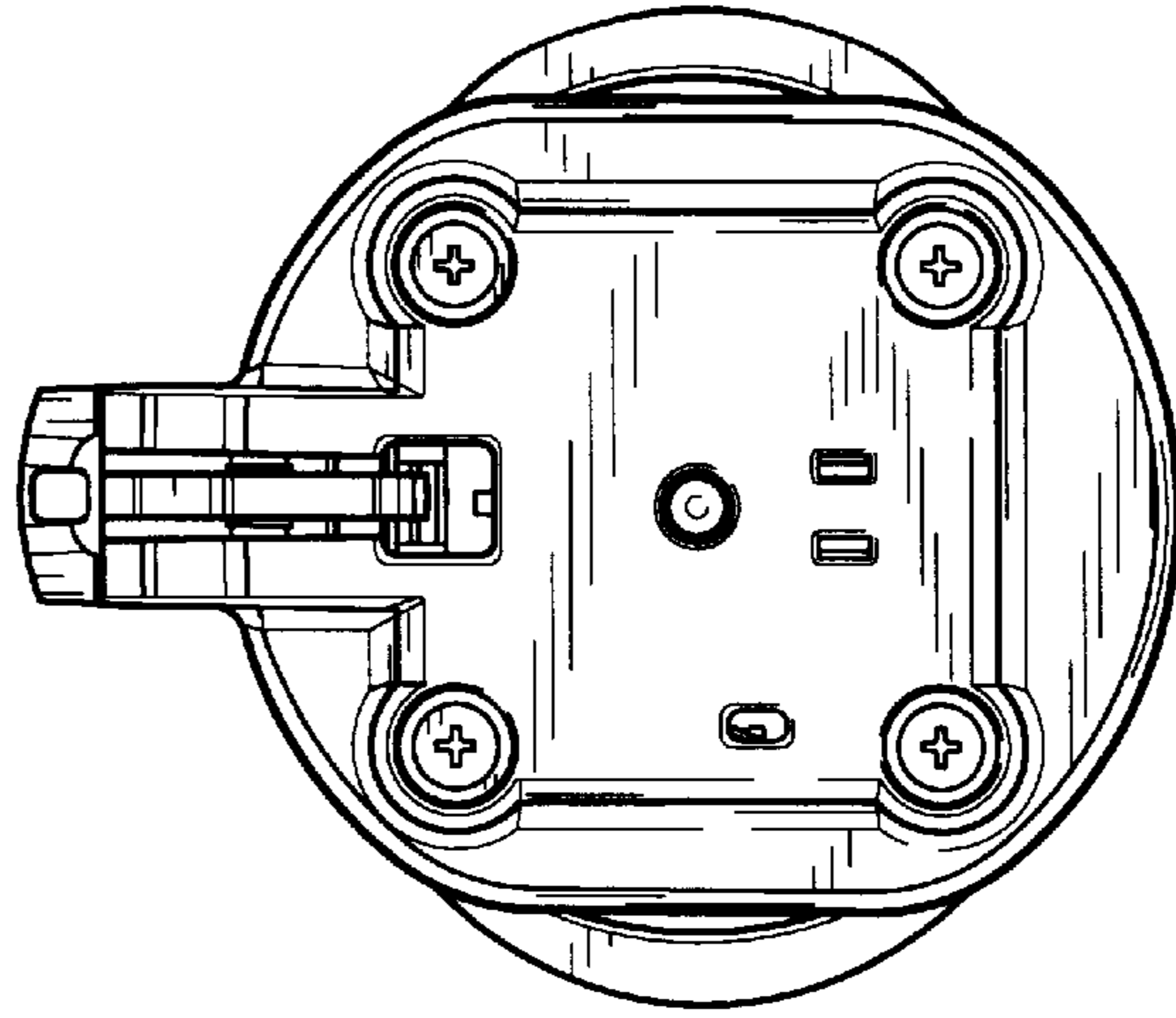

FIG. 42

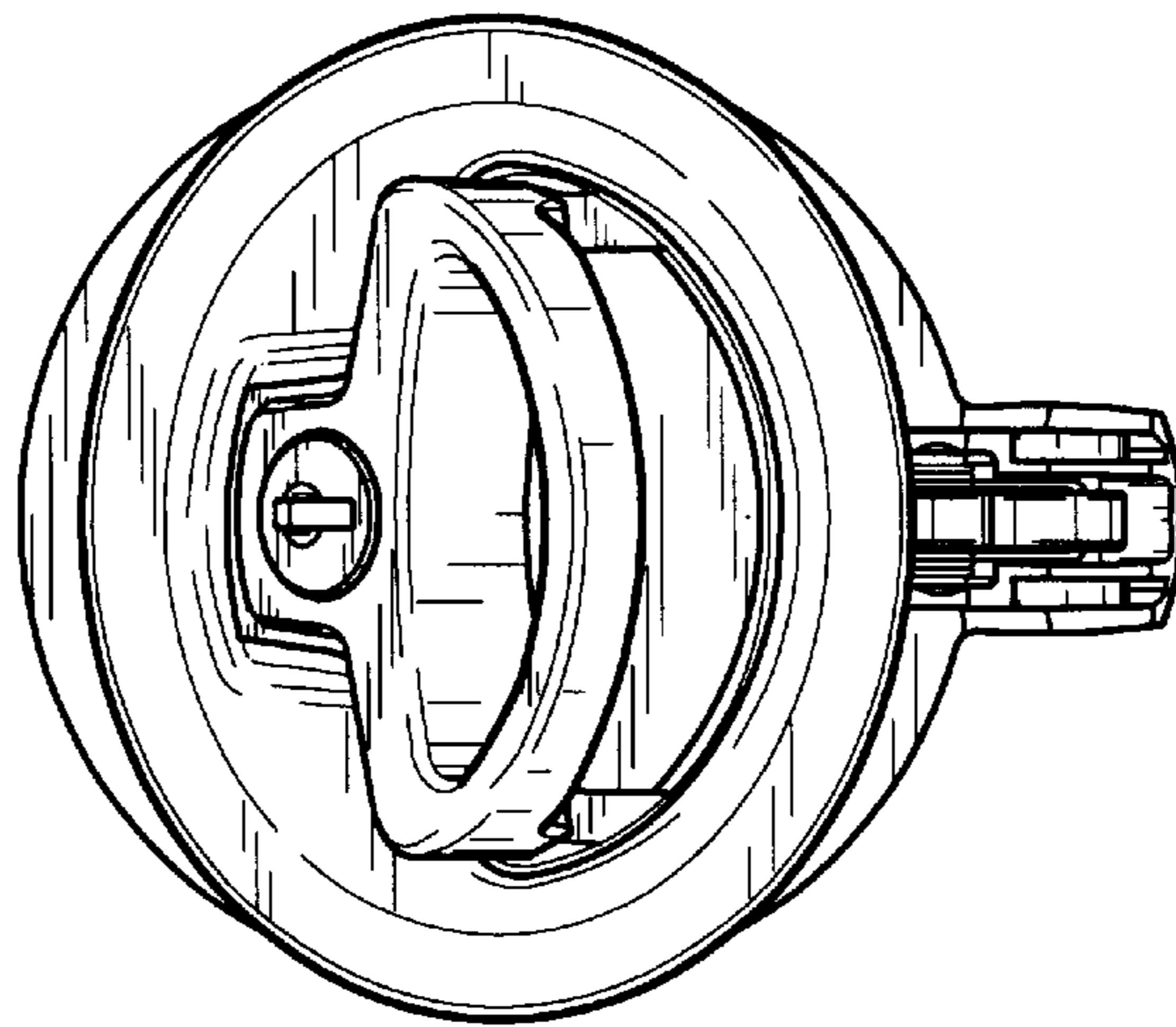

FIG. 41

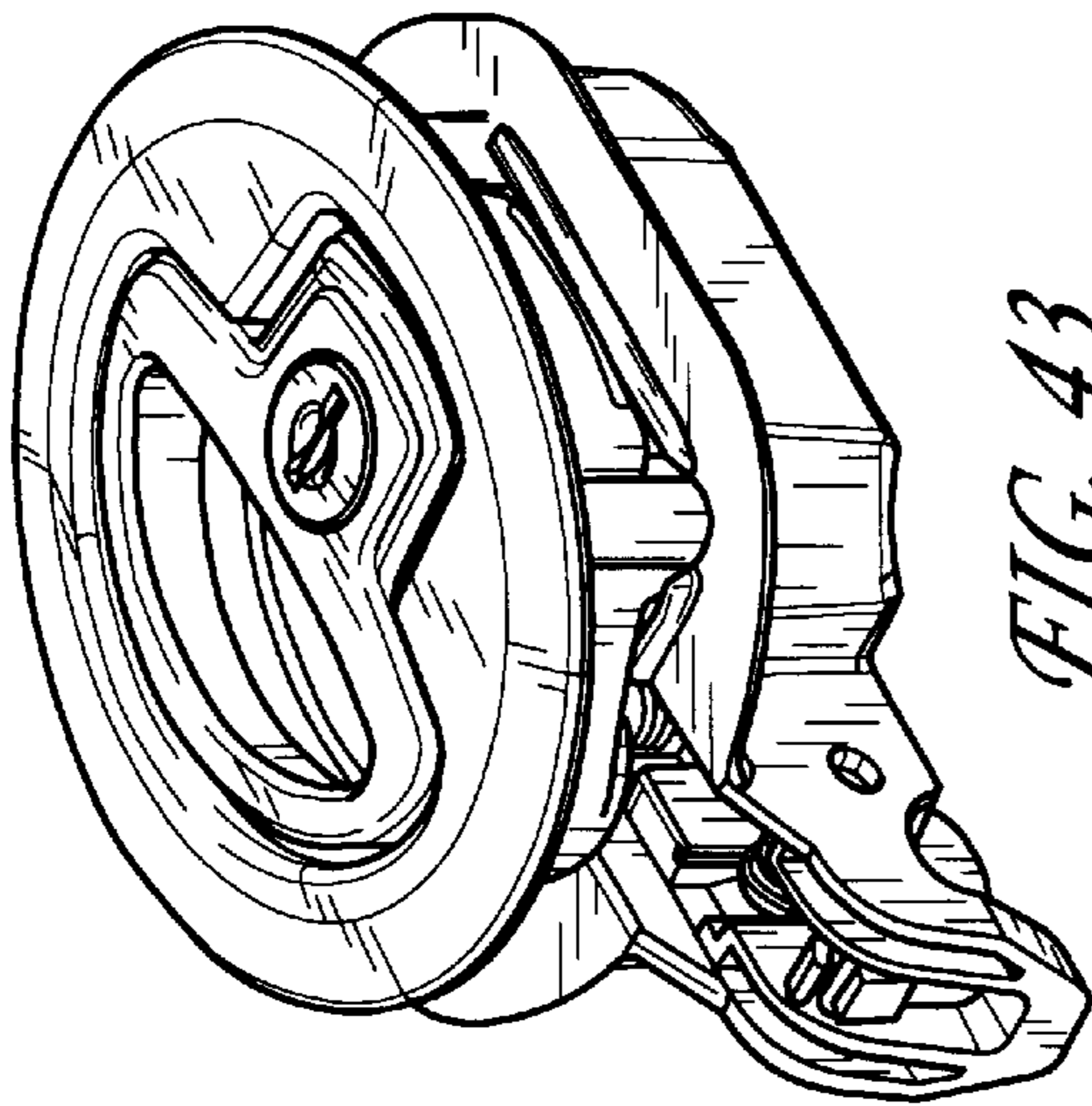

FIG. 43



FIG. 44

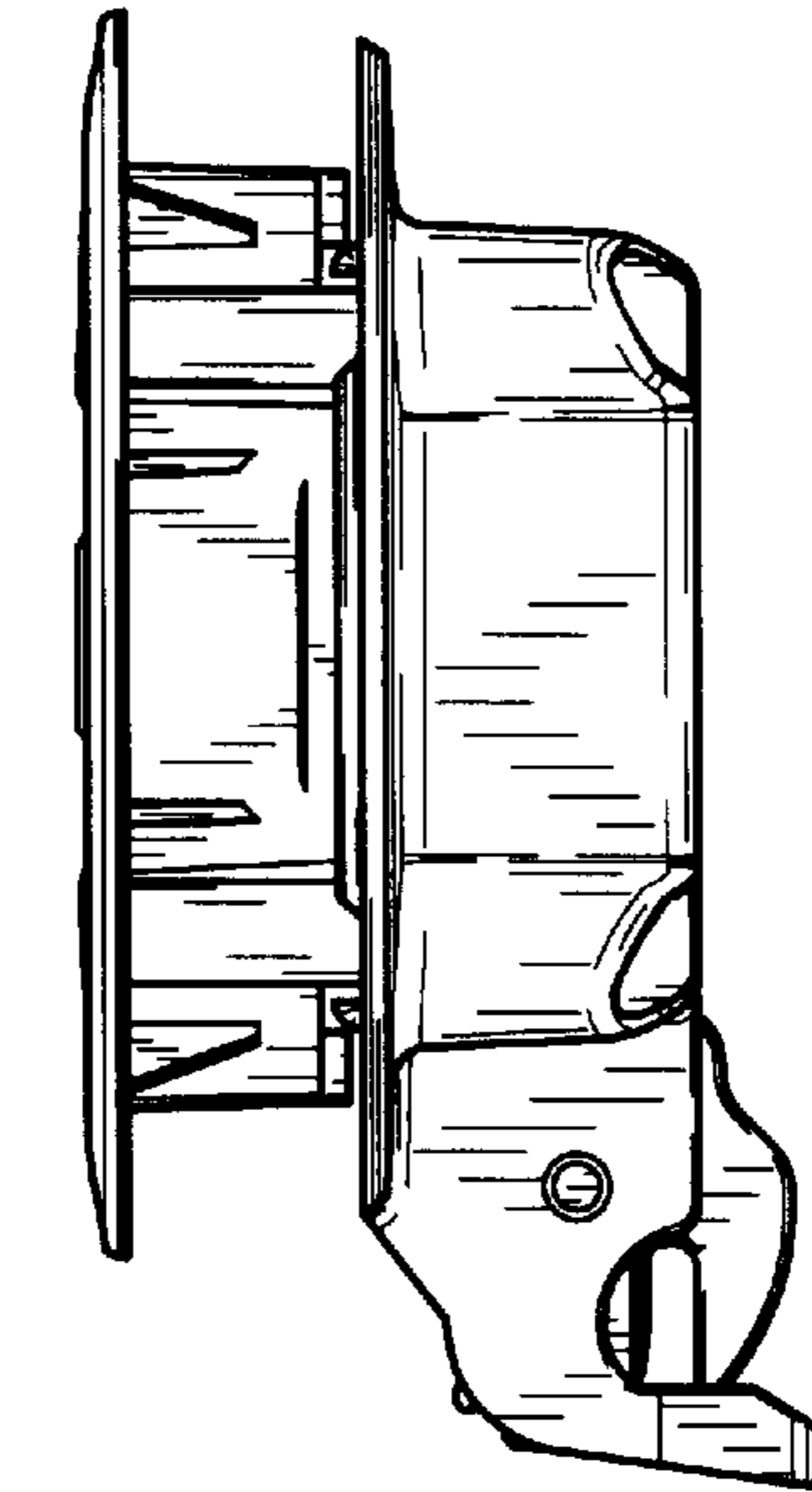

FIG. 45

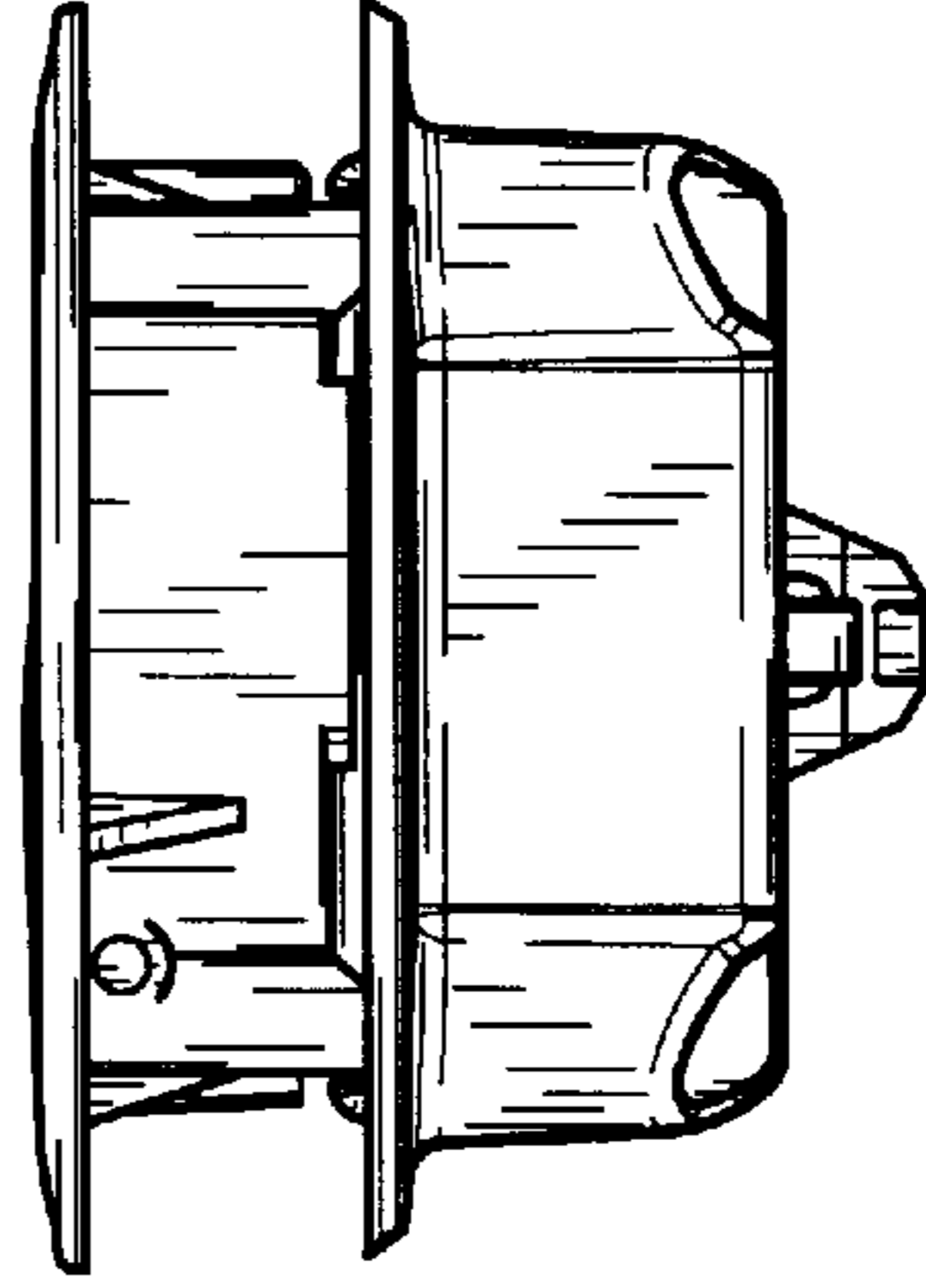

FIG. 46

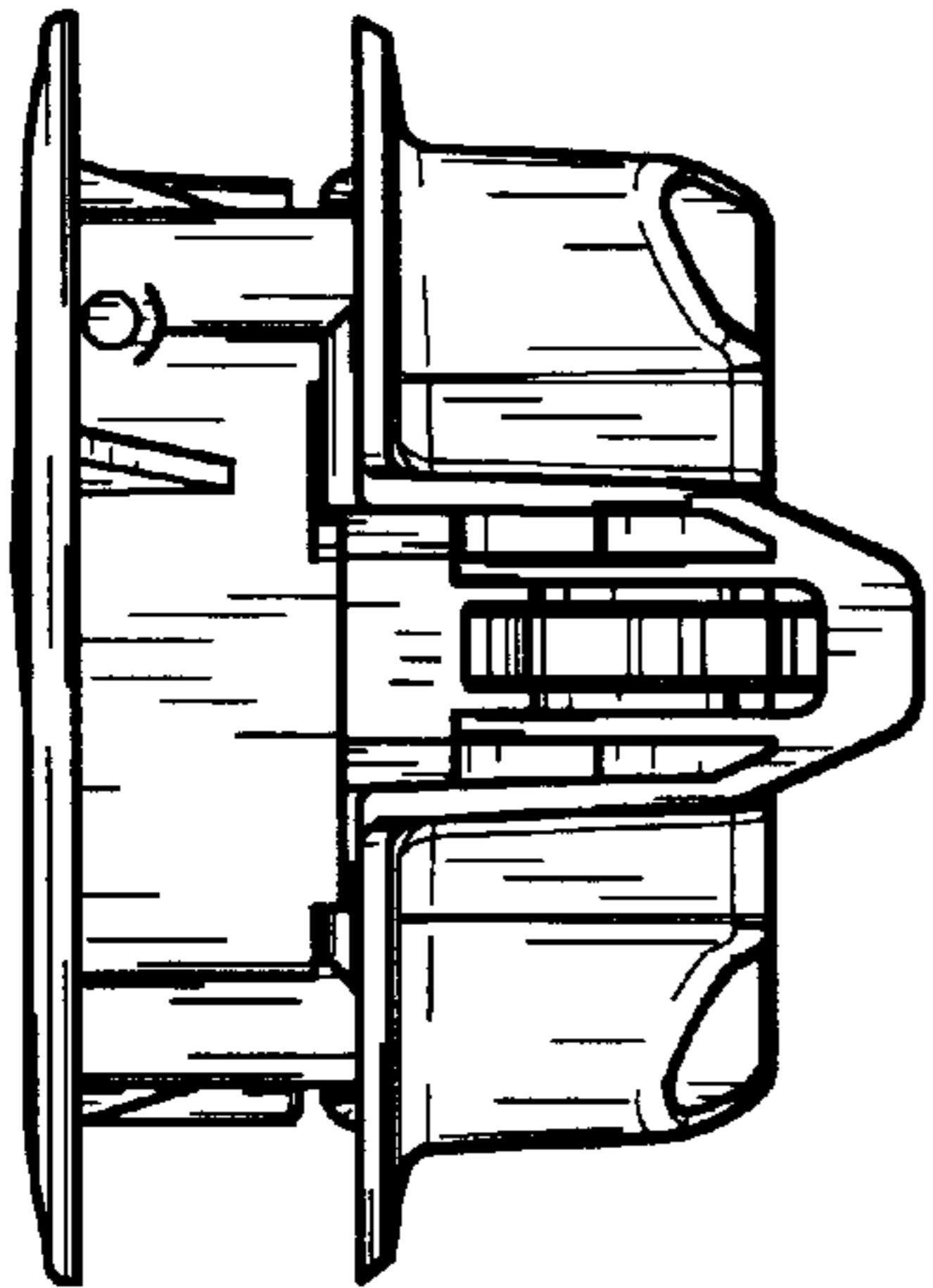

FIG. 47

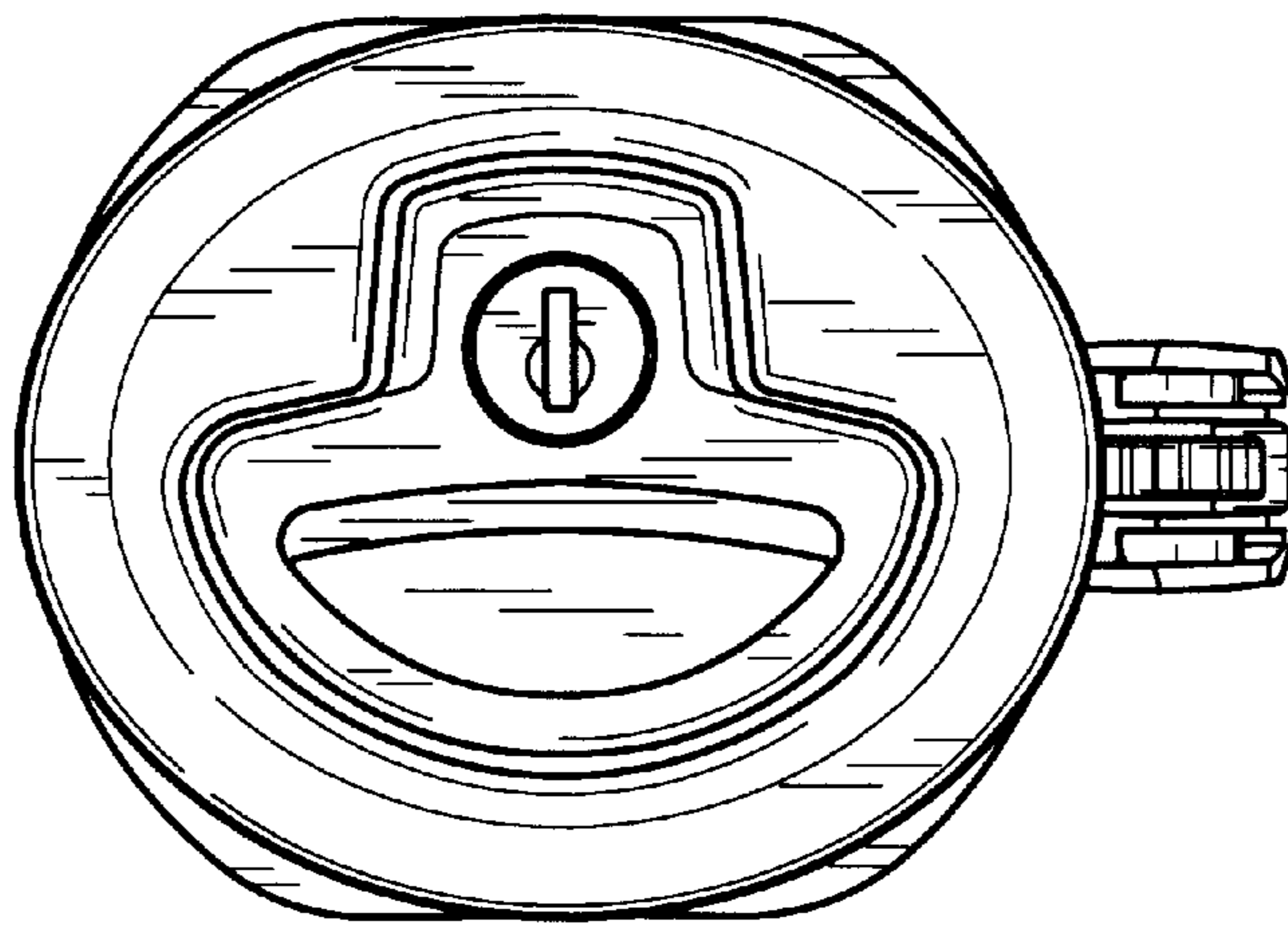

FIG. 48

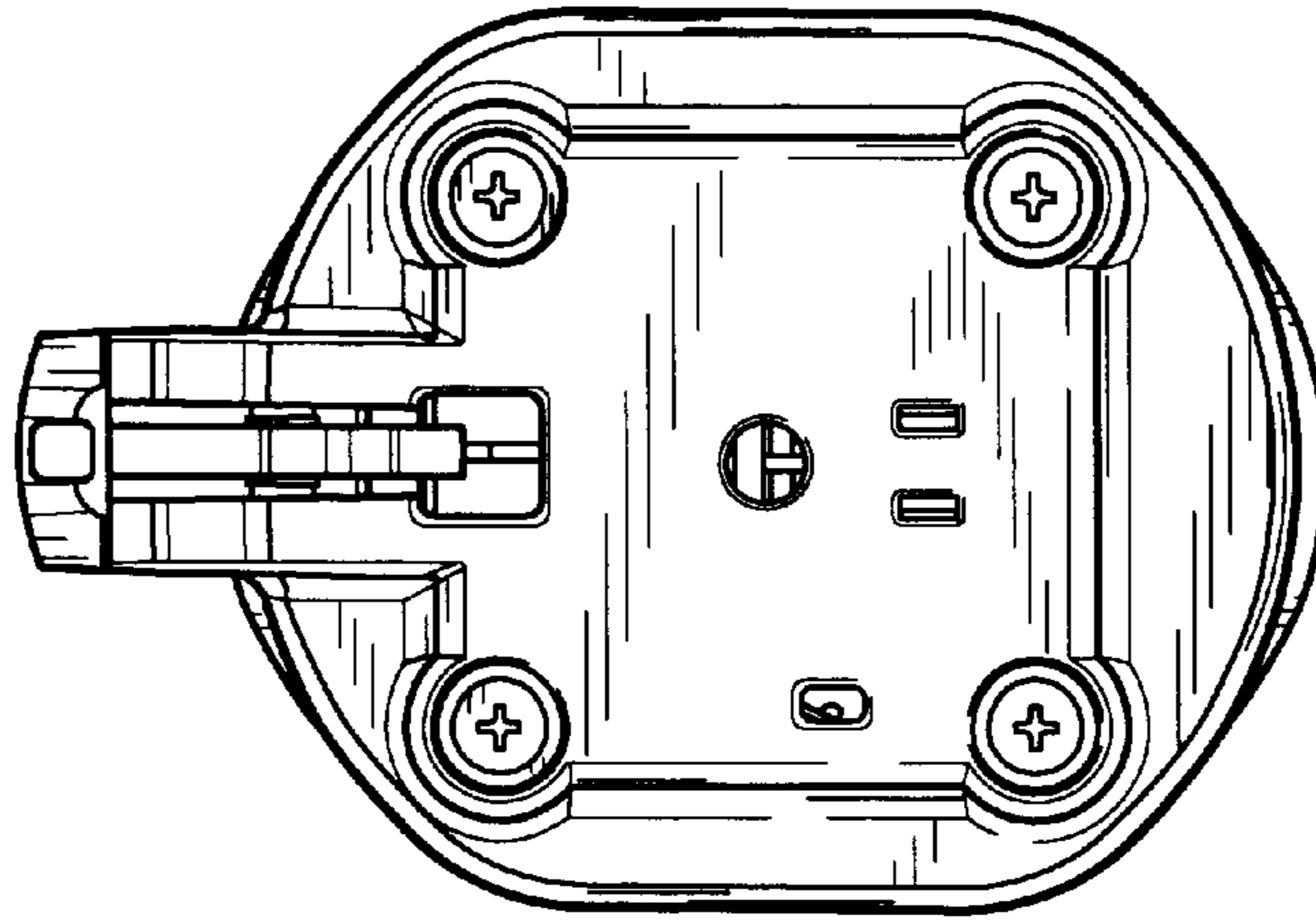
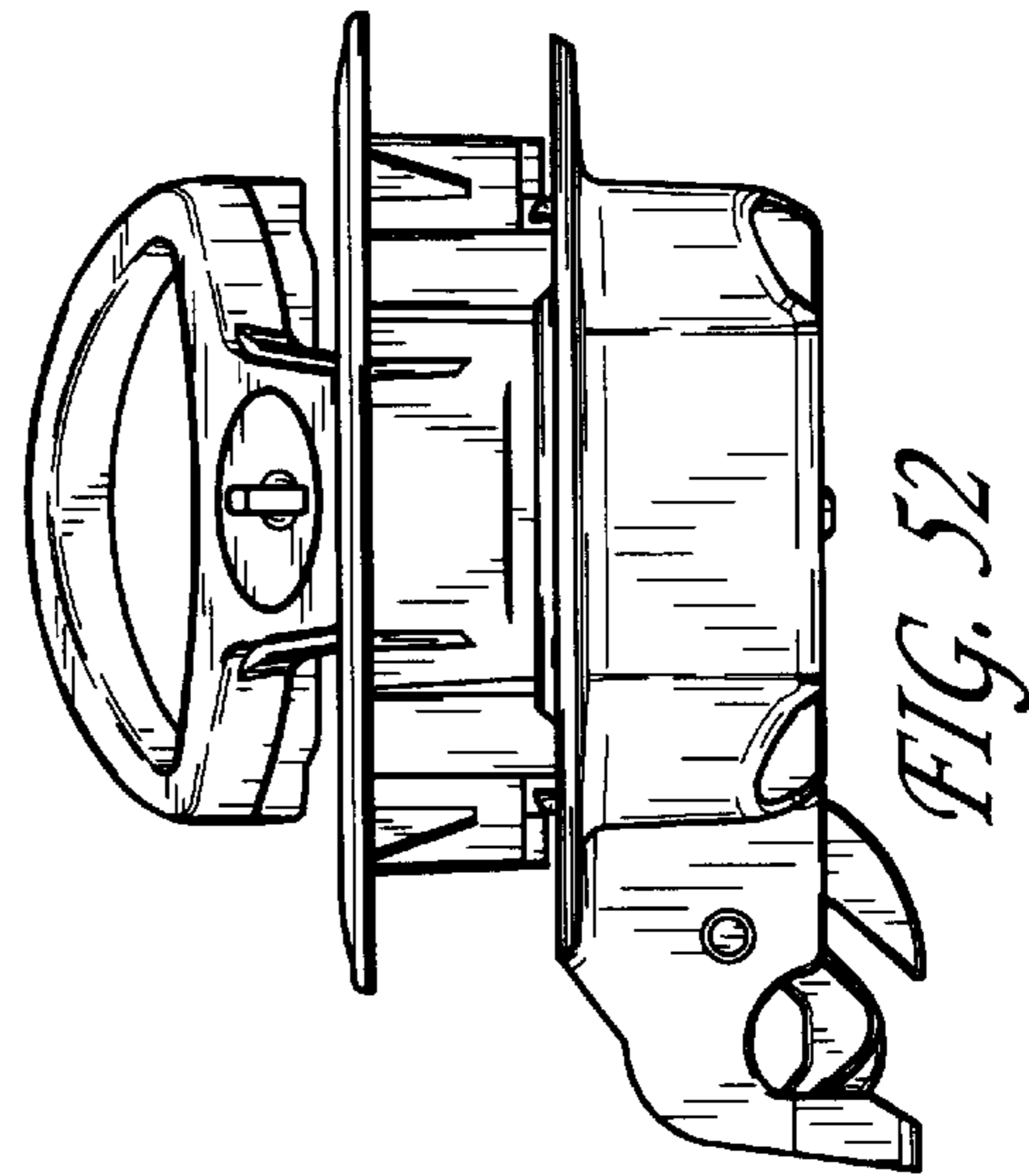
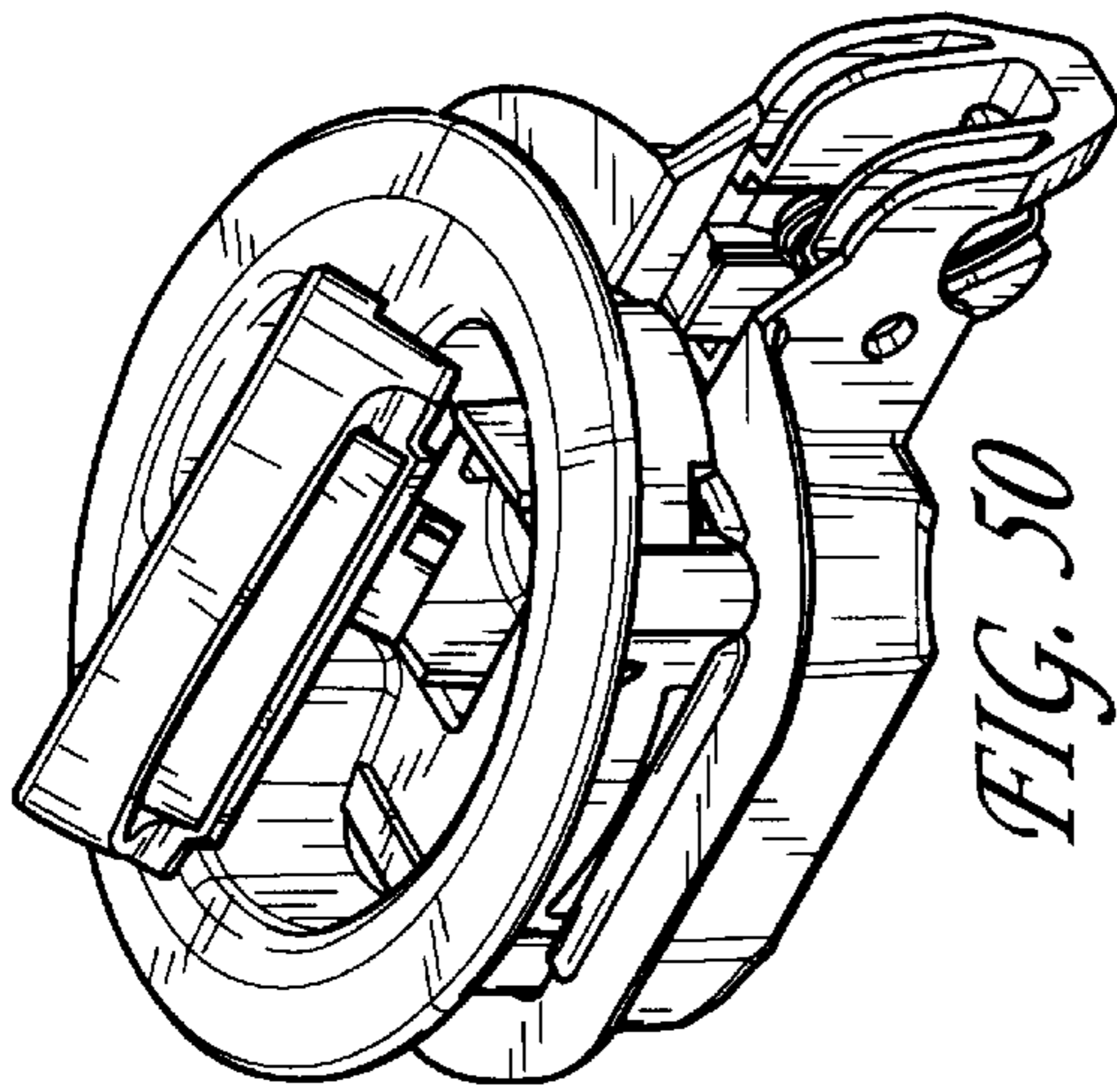
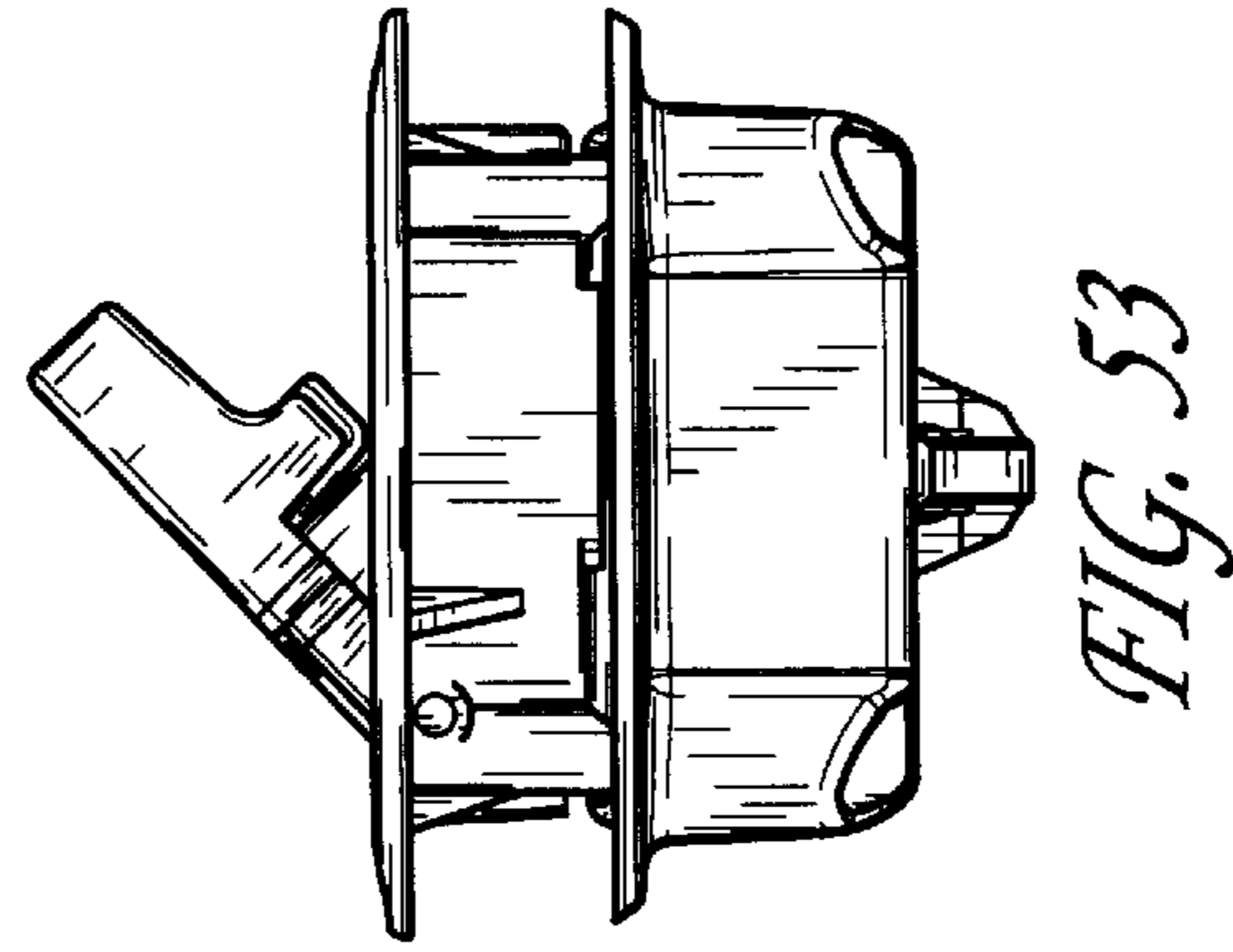
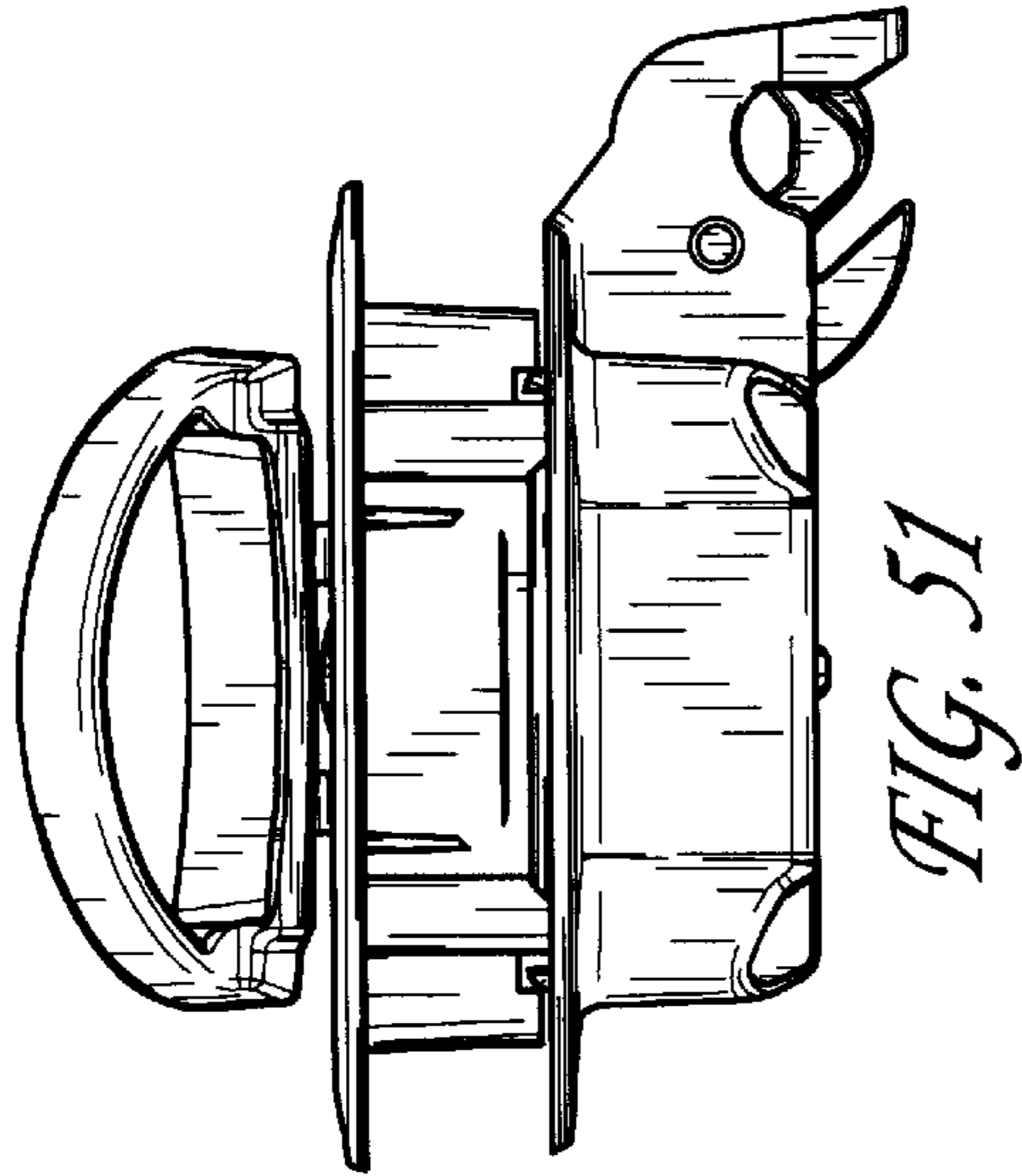

FIG. 49



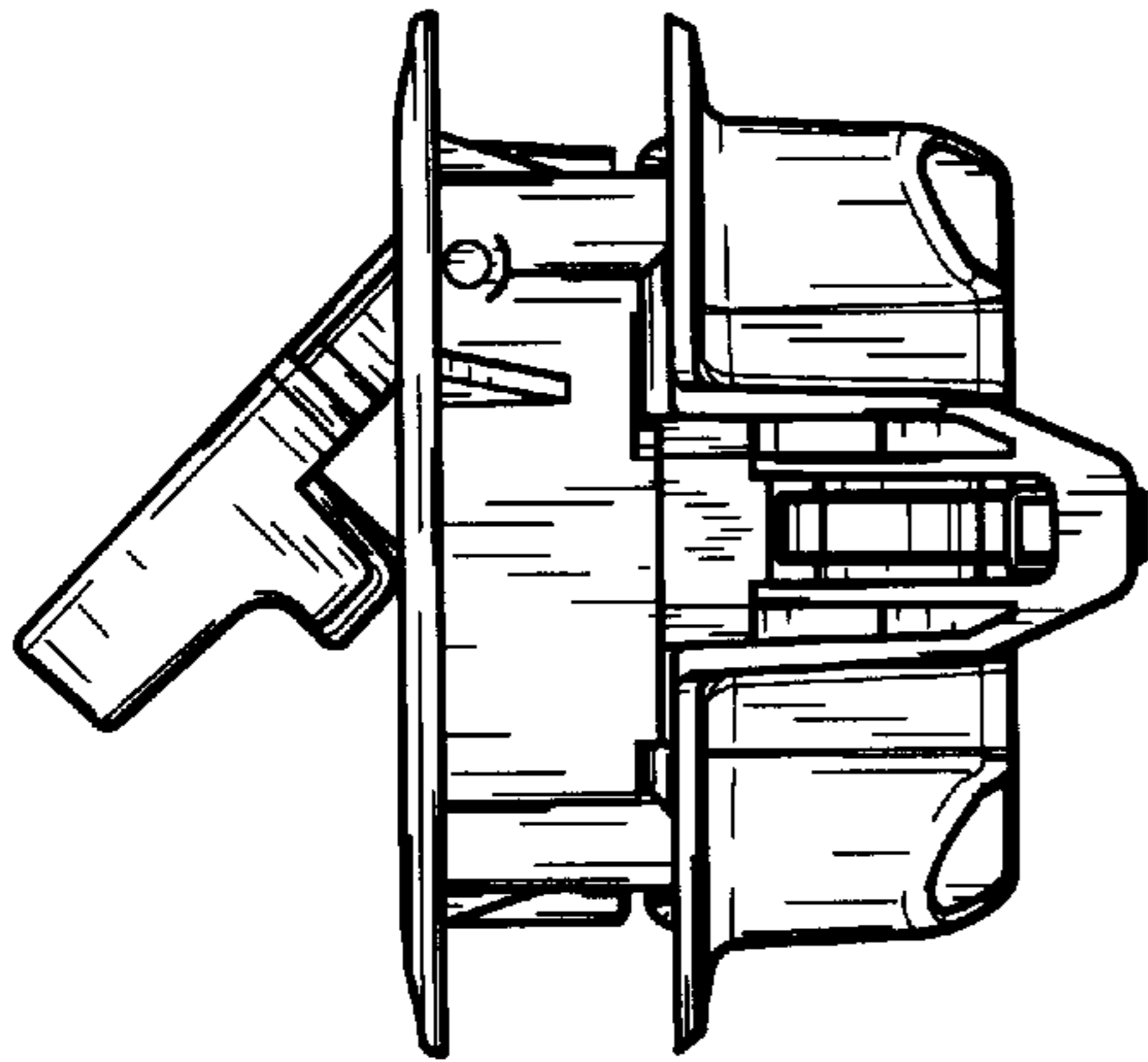

FIG. 54

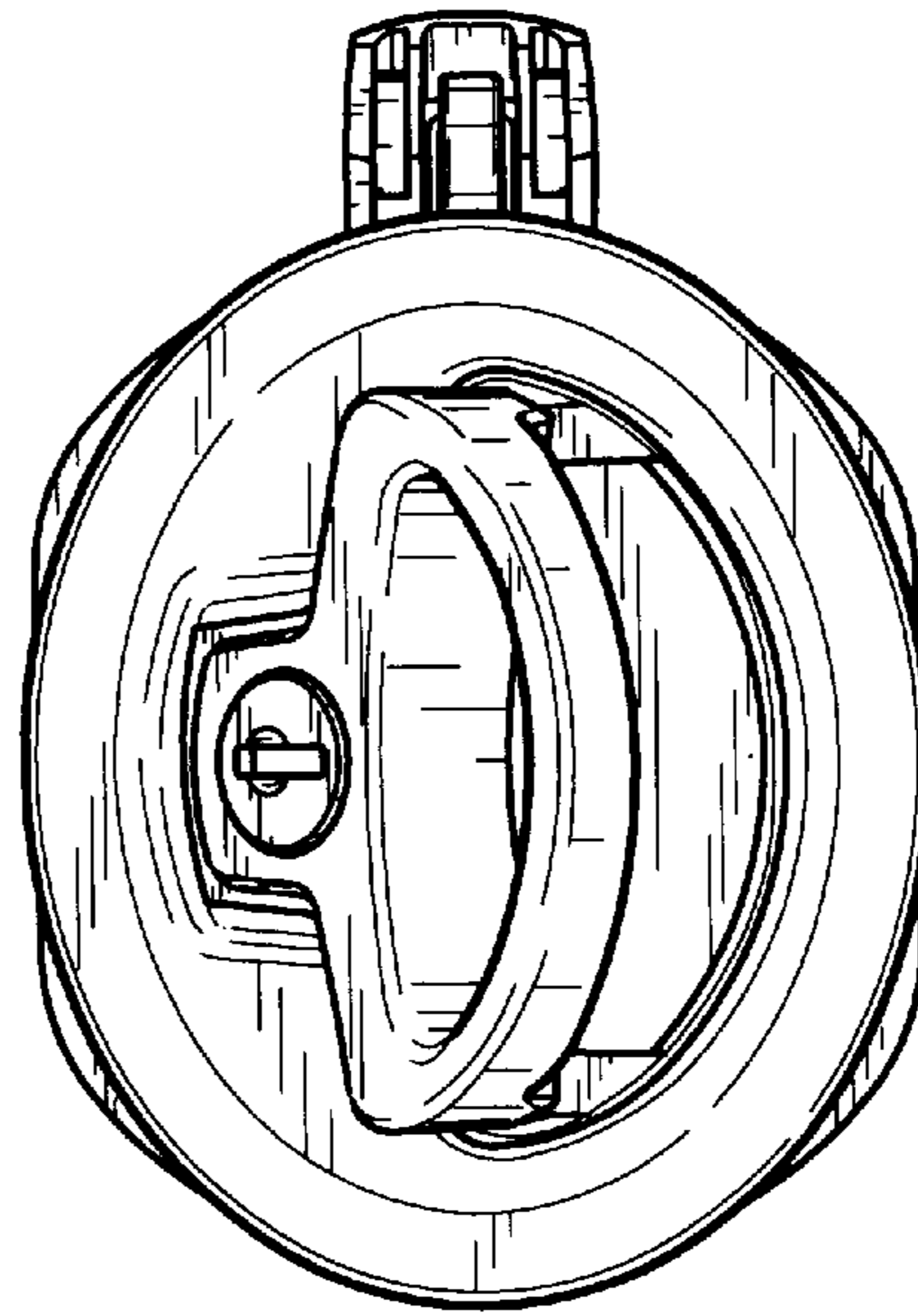

FIG. 55

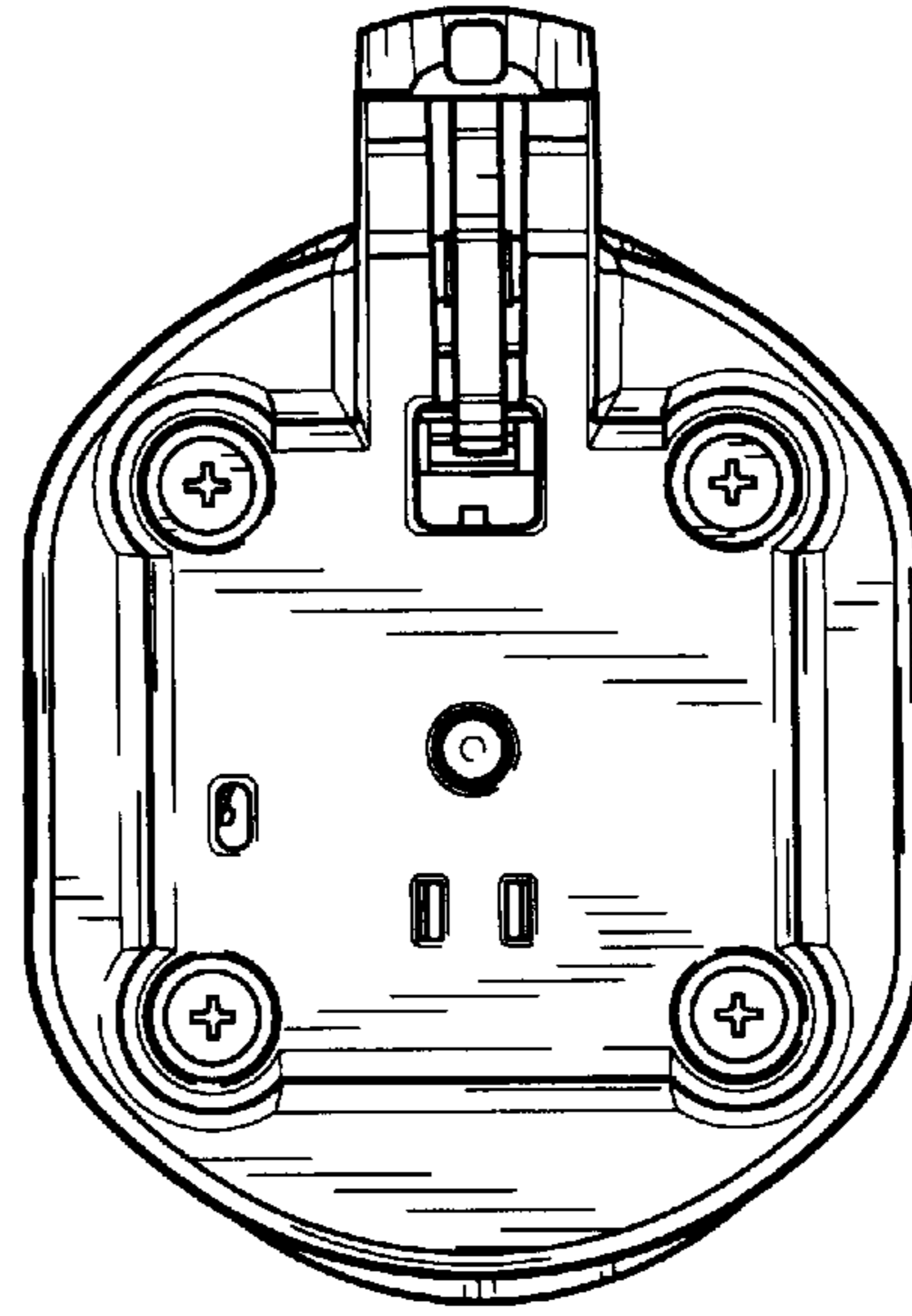

FIG. 56