



US00D505907S

(12) **United States Design Patent**
Bryham

(10) **Patent No.:** **US D505,907 S**
(45) **Date of Patent:** **** Jun. 7, 2005**

- (54) **BOAT**
- (75) **Inventor:** **Maurice John Bryham, Auckland (NZ)**
- (73) **Assignee:** **Sealegs International Limited, Auckland (NZ)**
- (**) **Term:** **14 Years**
- (21) **Appl. No.:** **29/185,032**
- (22) **Filed:** **Jun. 23, 2003**
- (30) **Foreign Application Priority Data**
Dec. 23, 2002 (NZ) 403199
- (51) **LOC (8) Cl. 12-06**
- (52) **U.S. Cl. D12/300**
- (58) **Field of Search D12/300, 310, D12/312, 314, 316; 441/35, 40, 41, 129, 130; 114/345, 344**

(56) **References Cited**

U.S. PATENT DOCUMENTS

1,002,661	A	*	9/1911	Erikson	114/344
2,890,466	A	*	6/1959	Bly	114/344
3,080,581	A	*	3/1963	Smihal	114/343
3,365,733	A	*	1/1968	Gudmundson	114/344
4,063,320	A	*	12/1977	Neumann et al.	114/345
4,352,337	A	*	10/1982	Wyoral	114/343
D279,668	S	*	7/1985	Larsson	D12/316
D290,108	S	*	6/1987	Wolfe	D12/316
4,894,033	A	*	1/1990	Chang	441/40
5,791,279	A	*	8/1998	Hart	114/344
6,012,410	A	*	1/2000	Monlezun et al.	114/345
2002/0017229	A1	*	2/2002	Pavon et al.	114/344

* cited by examiner

Primary Examiner—Alan P. Douglas
Assistant Examiner—Cynthia M. Chin

(74) *Attorney, Agent, or Firm*—Young & Thompson

(57) **CLAIM**

The ornamental design for a boat, substantially as shown and described.

DESCRIPTION

FIG. 1 is a top plan view of a boat, showing my new design with the wheels up,
 FIG. 2 is a bottom view thereof, with wheels up,
 FIG. 3 is a top plan view thereof, with the wheels down,
 FIG. 4 is a bottom view thereof, with wheels down,
 FIG. 5 is a left side elevation view thereof, with wheels up,
 FIG. 6 is a right side elevation view thereof, with wheels up,
 FIG. 7 is a left side elevation view thereof, with wheels down,
 FIG. 8 is a right side elevation view thereof, with wheels down,
 FIG. 9 is a front elevation view thereof, with wheels up
 FIG. 10 is a rear elevation view thereof, with wheels up
 FIG. 11 is a front elevation view thereof, with wheels down
 FIG. 12 is a rear elevation view thereof, with wheels down
 FIG. 13 is a front top left perspective view thereof, with wheels up,
 FIG. 14 is a front top left perspective view thereof, with wheels down,
 FIG. 15 is a rear top left perspective view thereof, with wheels up,
 FIG. 16 is a rear top left perspective view thereof, with wheels down,
 FIG. 17 is a front left bottom perspective view thereof, with wheels up; and,
 FIG. 18 is a front left bottom perspective view thereof, with wheels down, and the boat has a retractable undercarriage system, and the accompanying drawings show the appearance of the boat with its wheels up, and the appearance of the same boat with its wheels down.

1 Claim, 11 Drawing Sheets

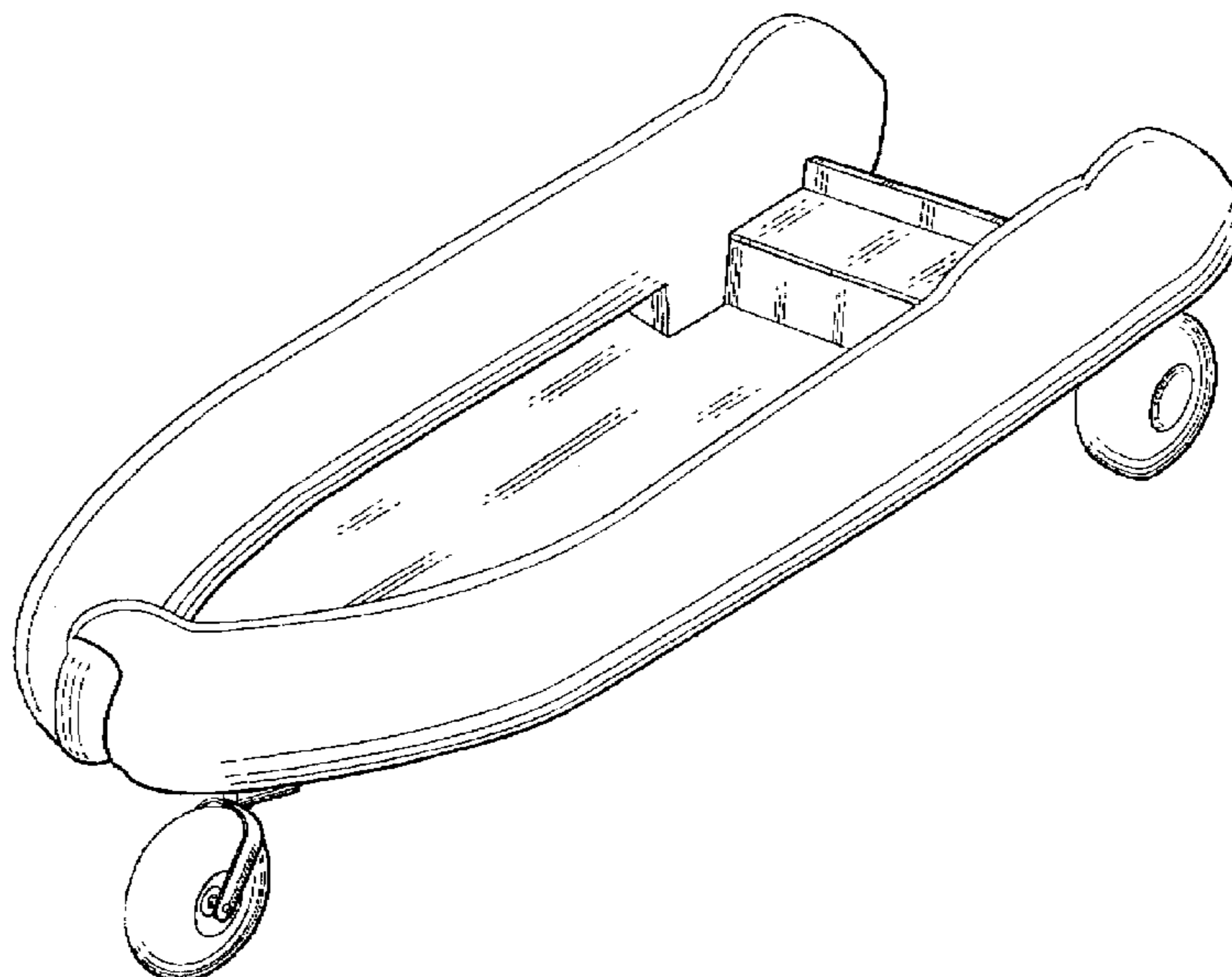

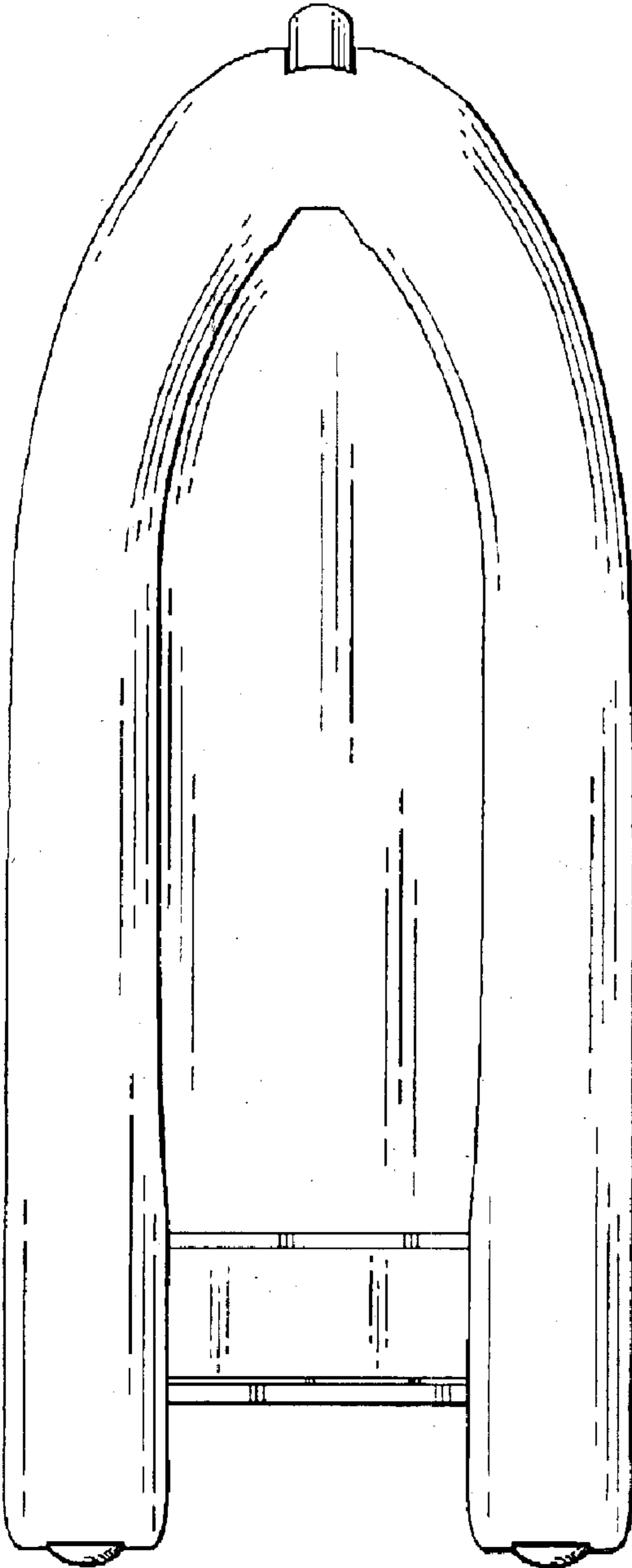

FIG. 1

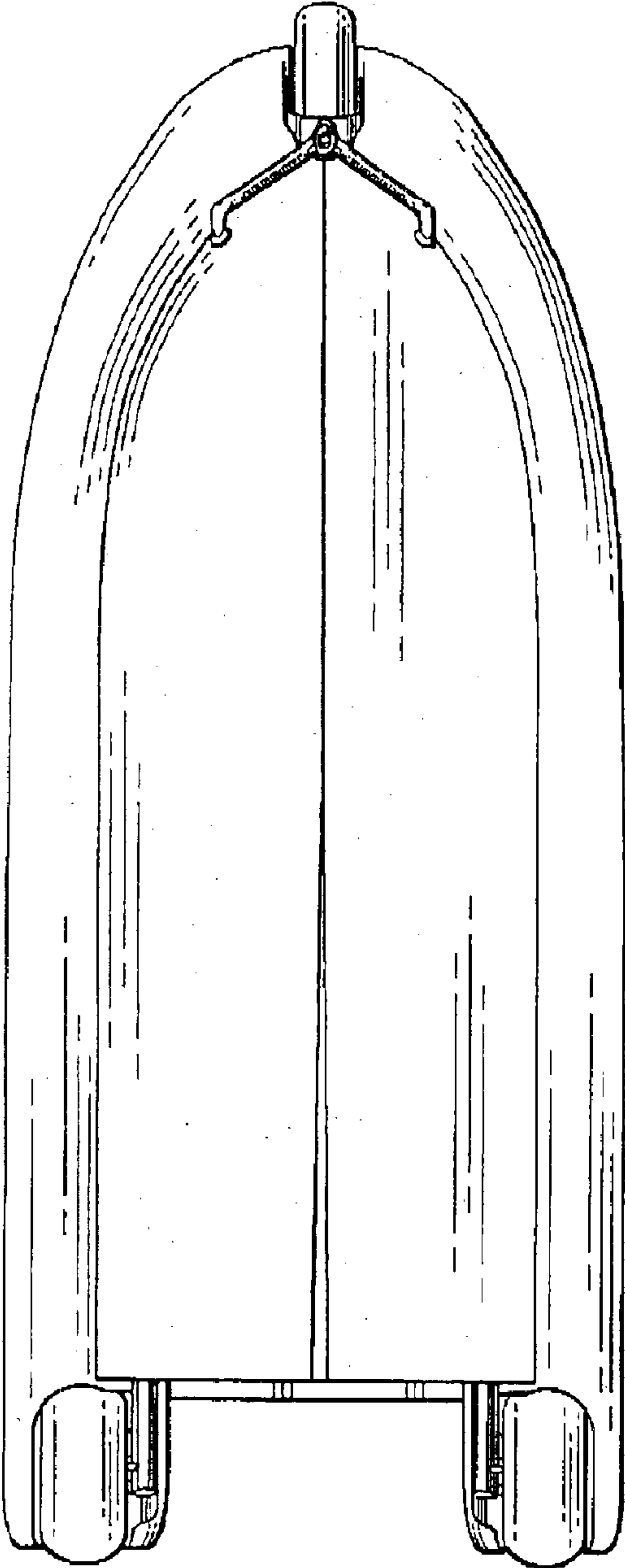

FIG. 2

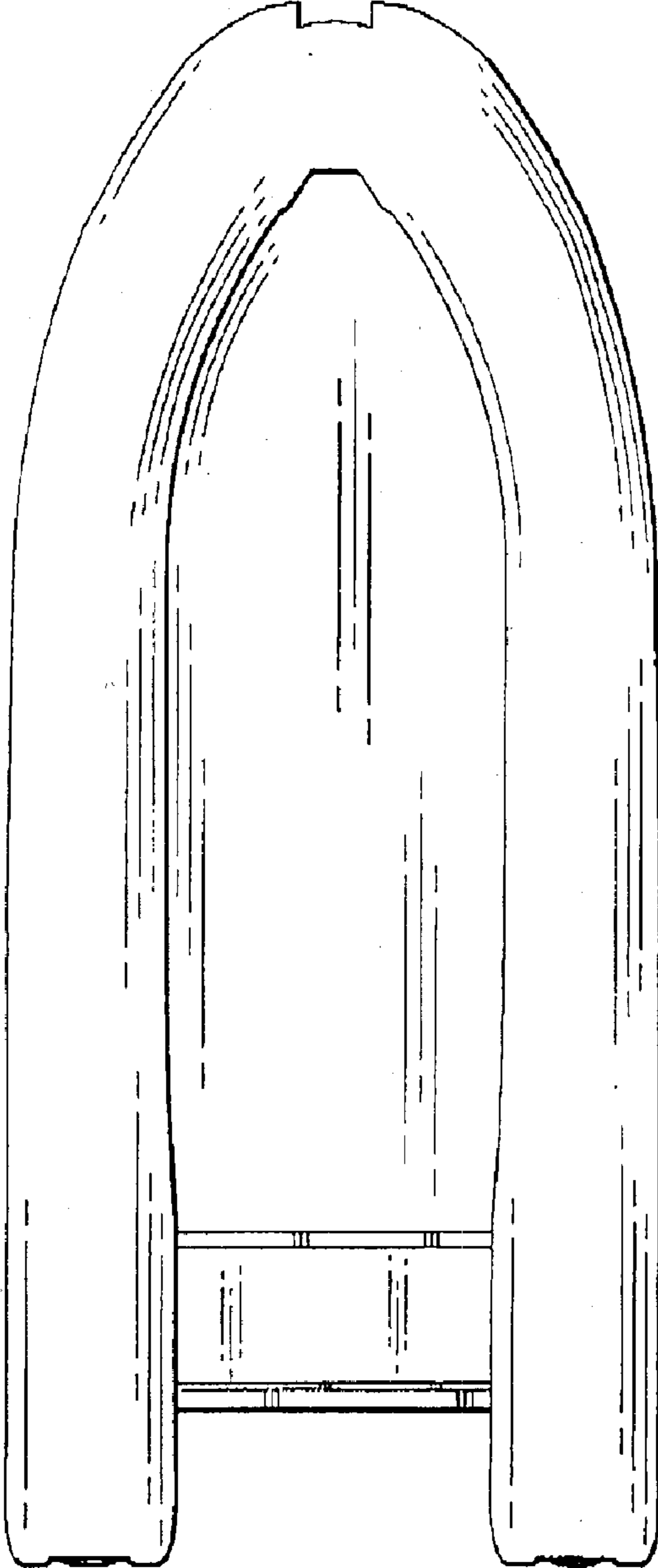

FIG. 3

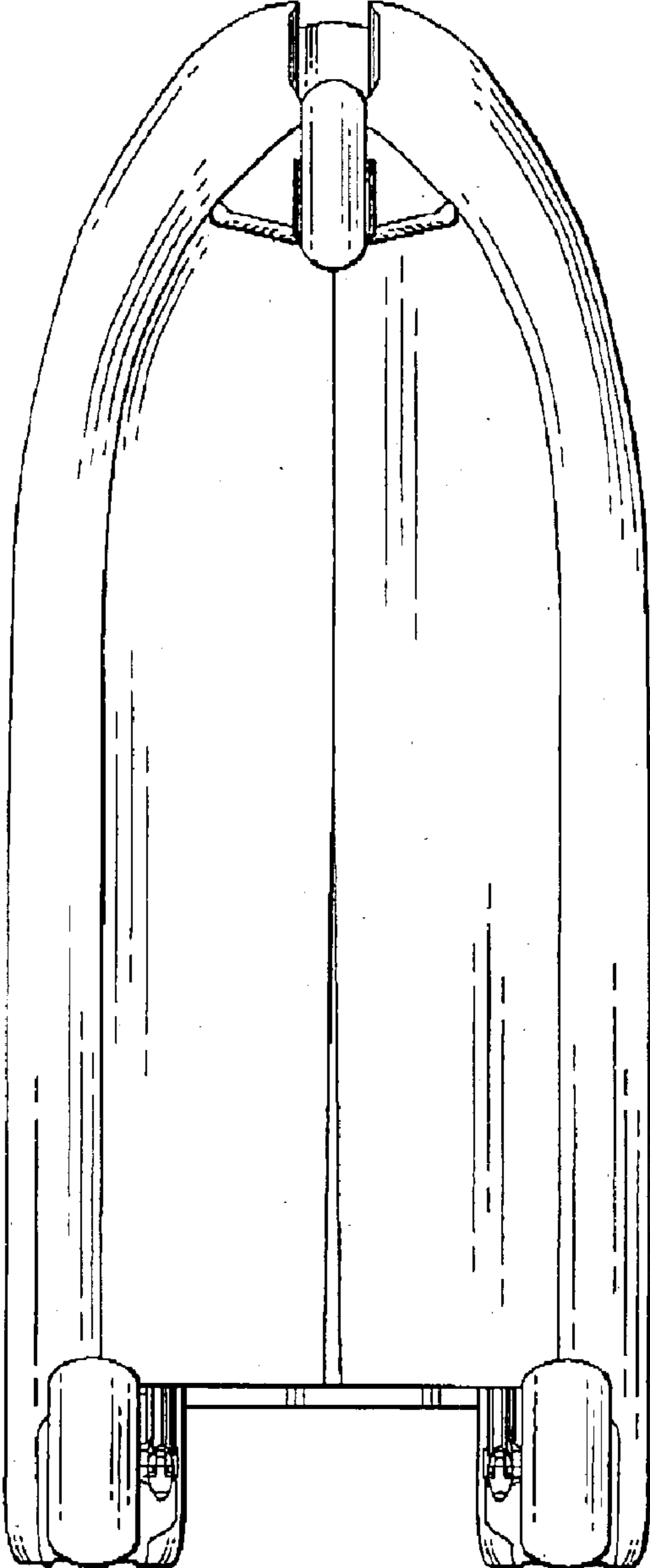

FIG. 4

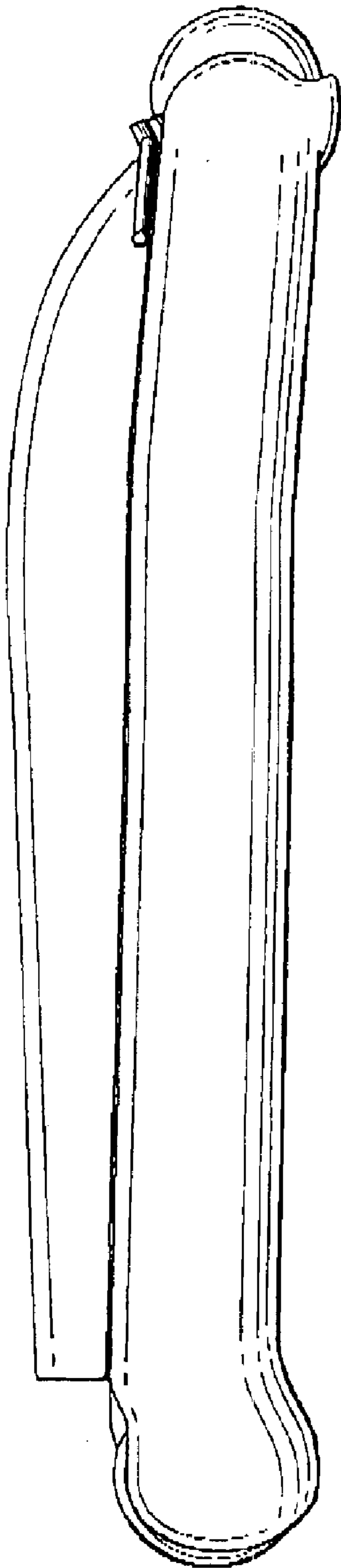

FIG. 5

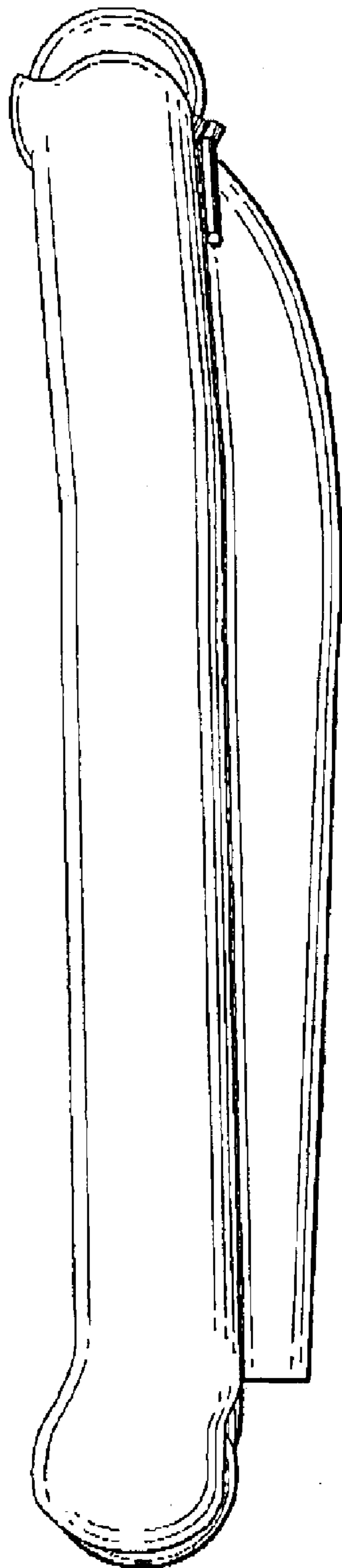

FIG. 6

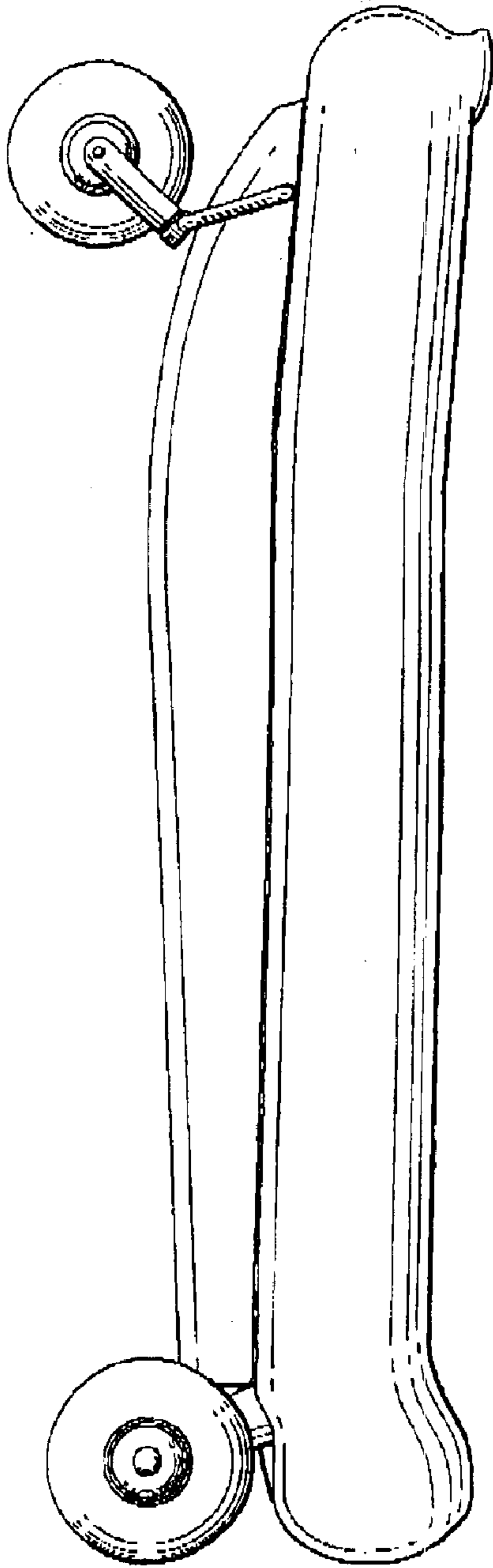

FIG. 7

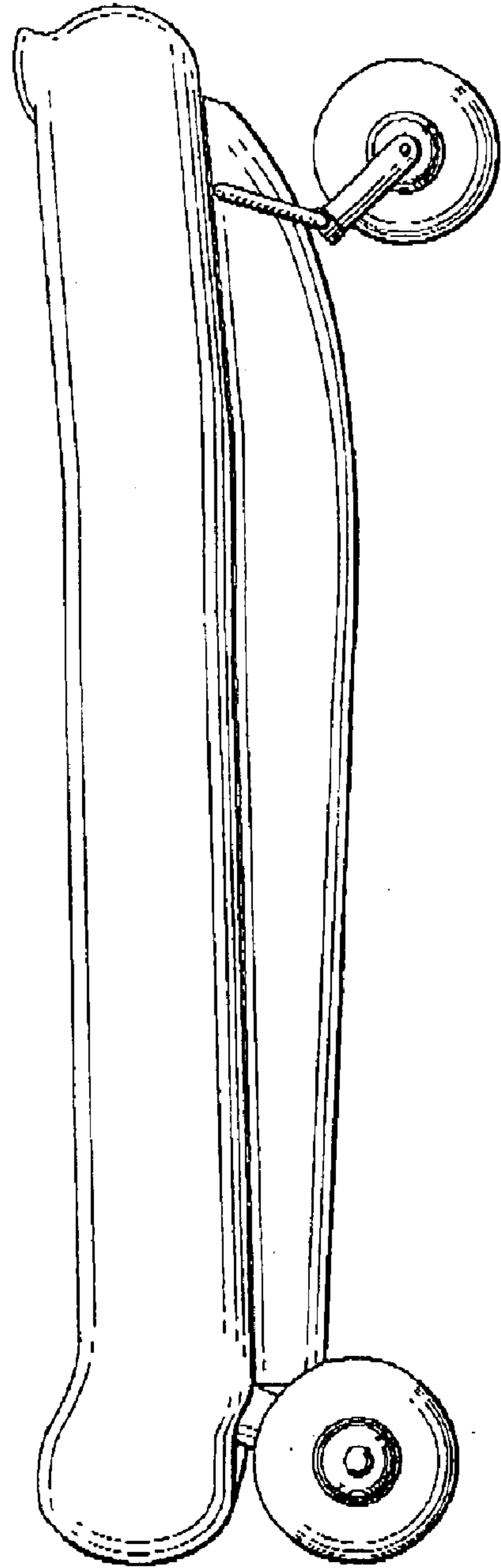

FIG. 8

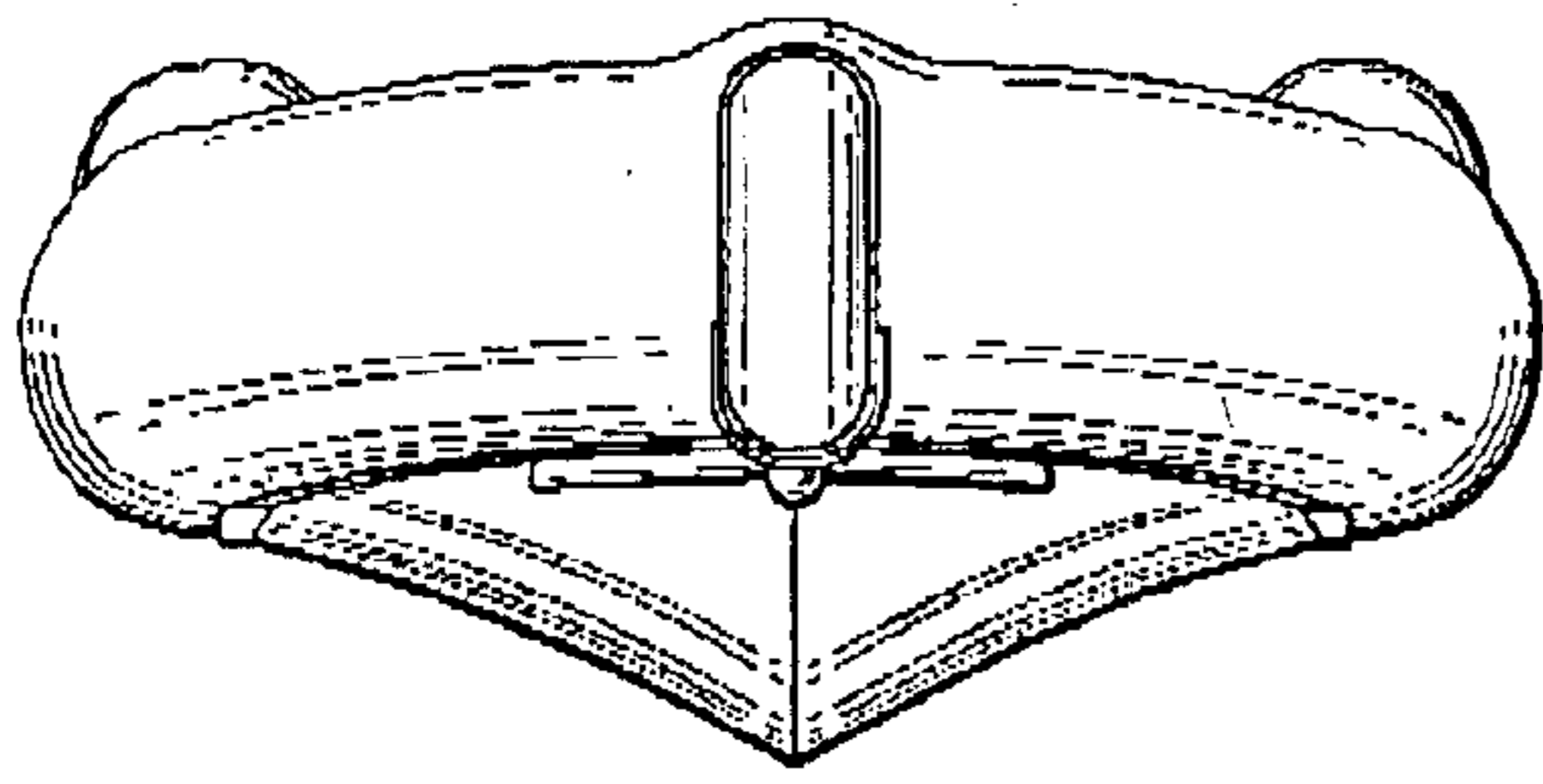

FIG. 9

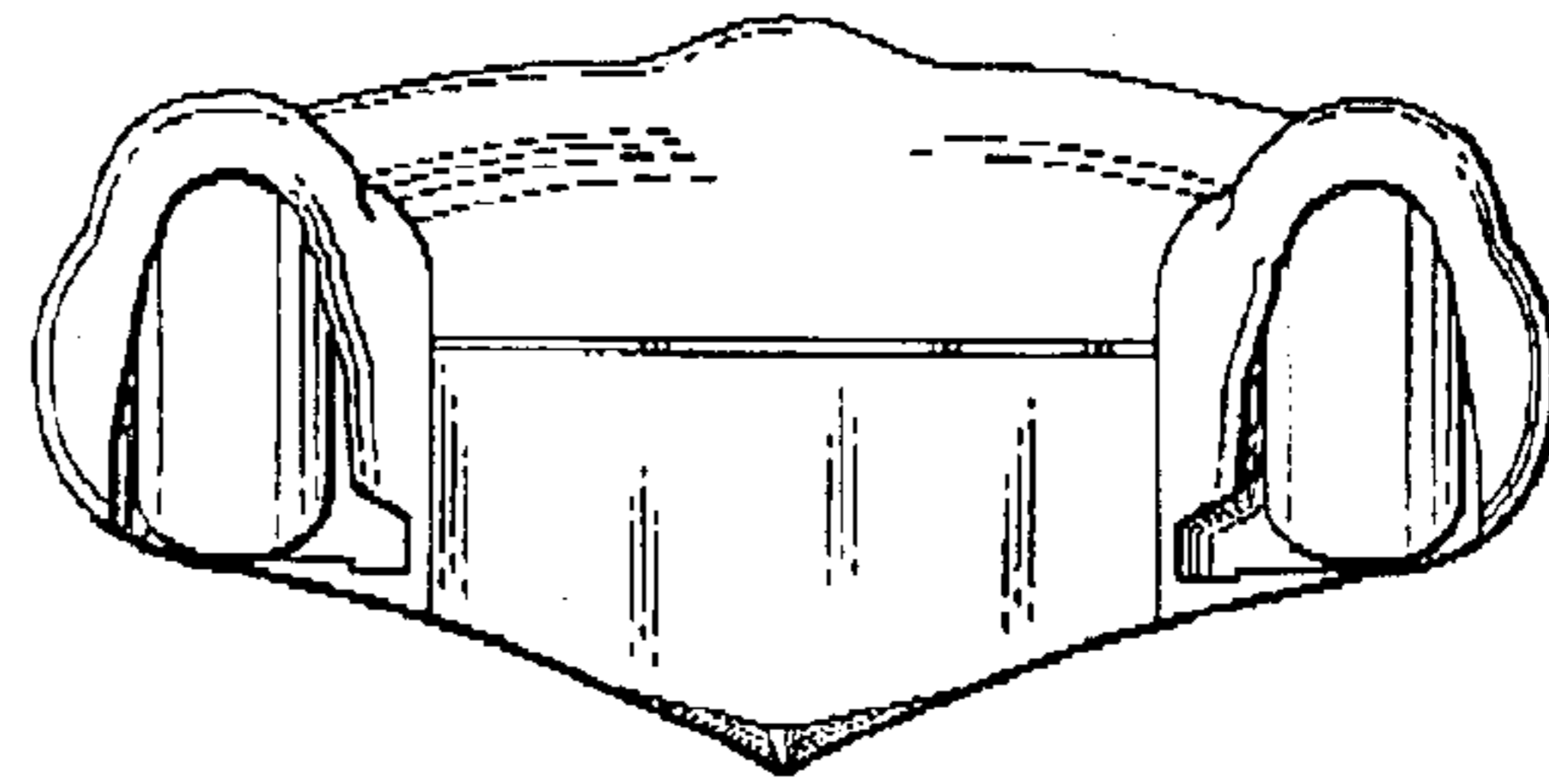

FIG. 10

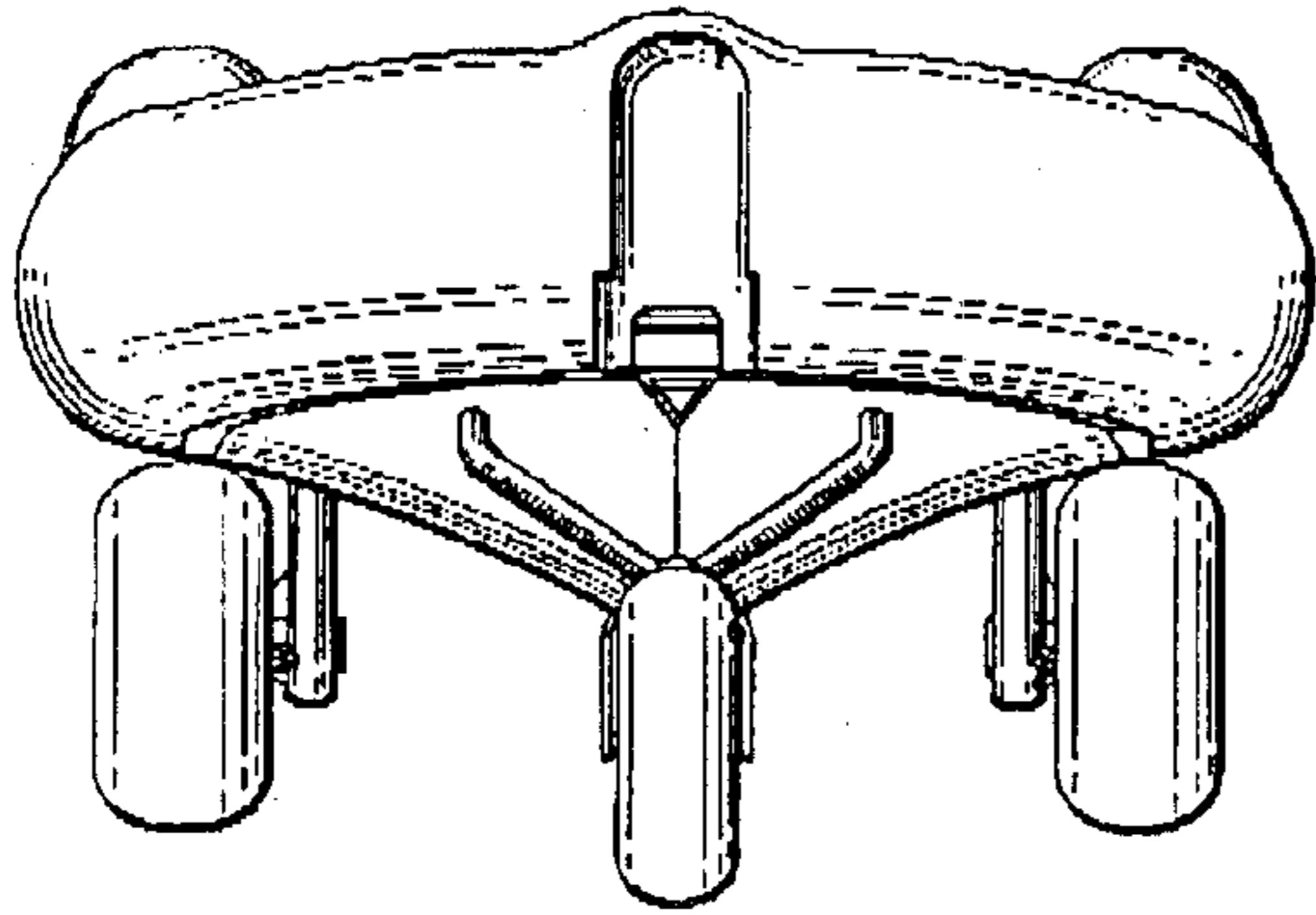

FIG. 11

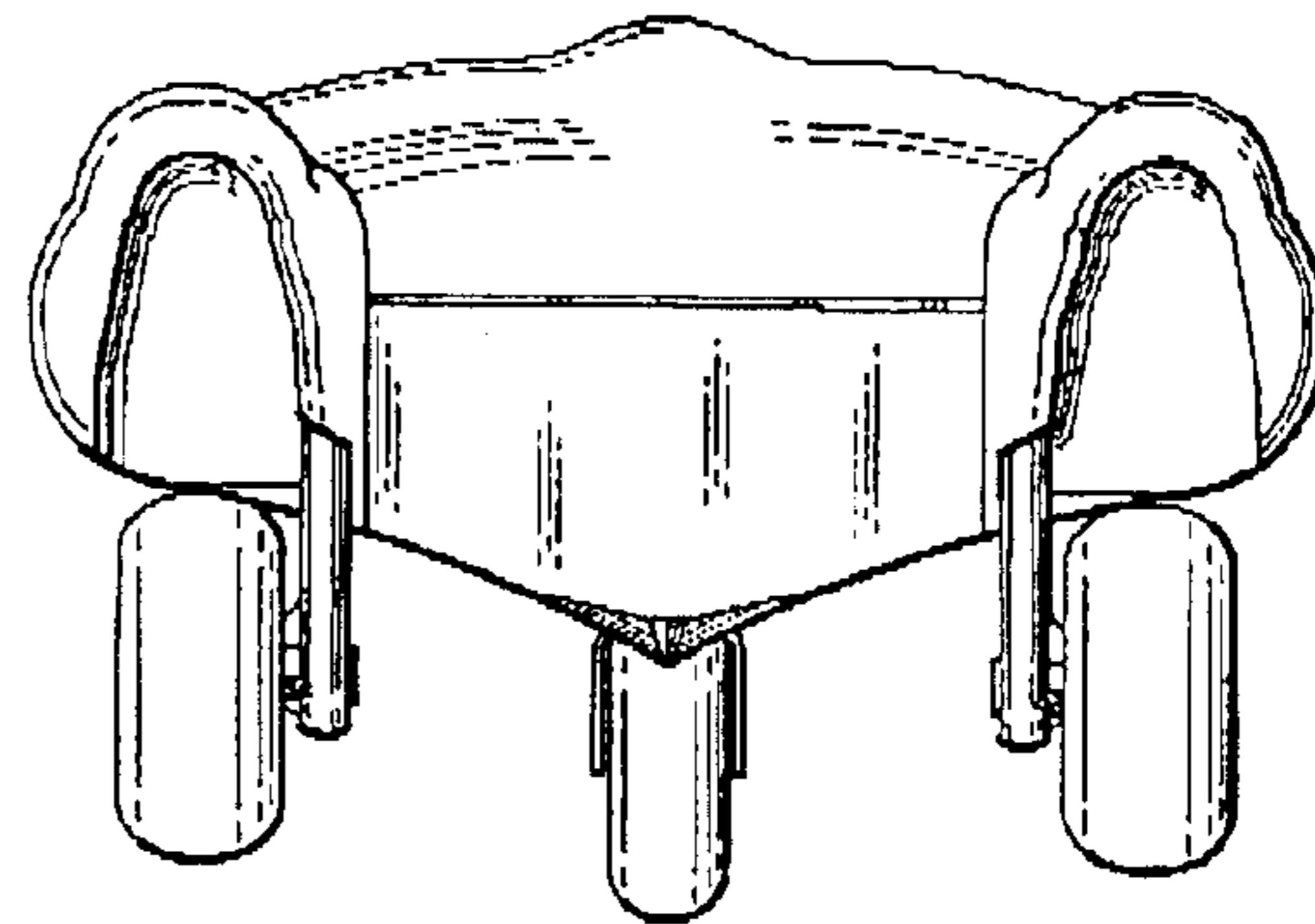

FIG. 12

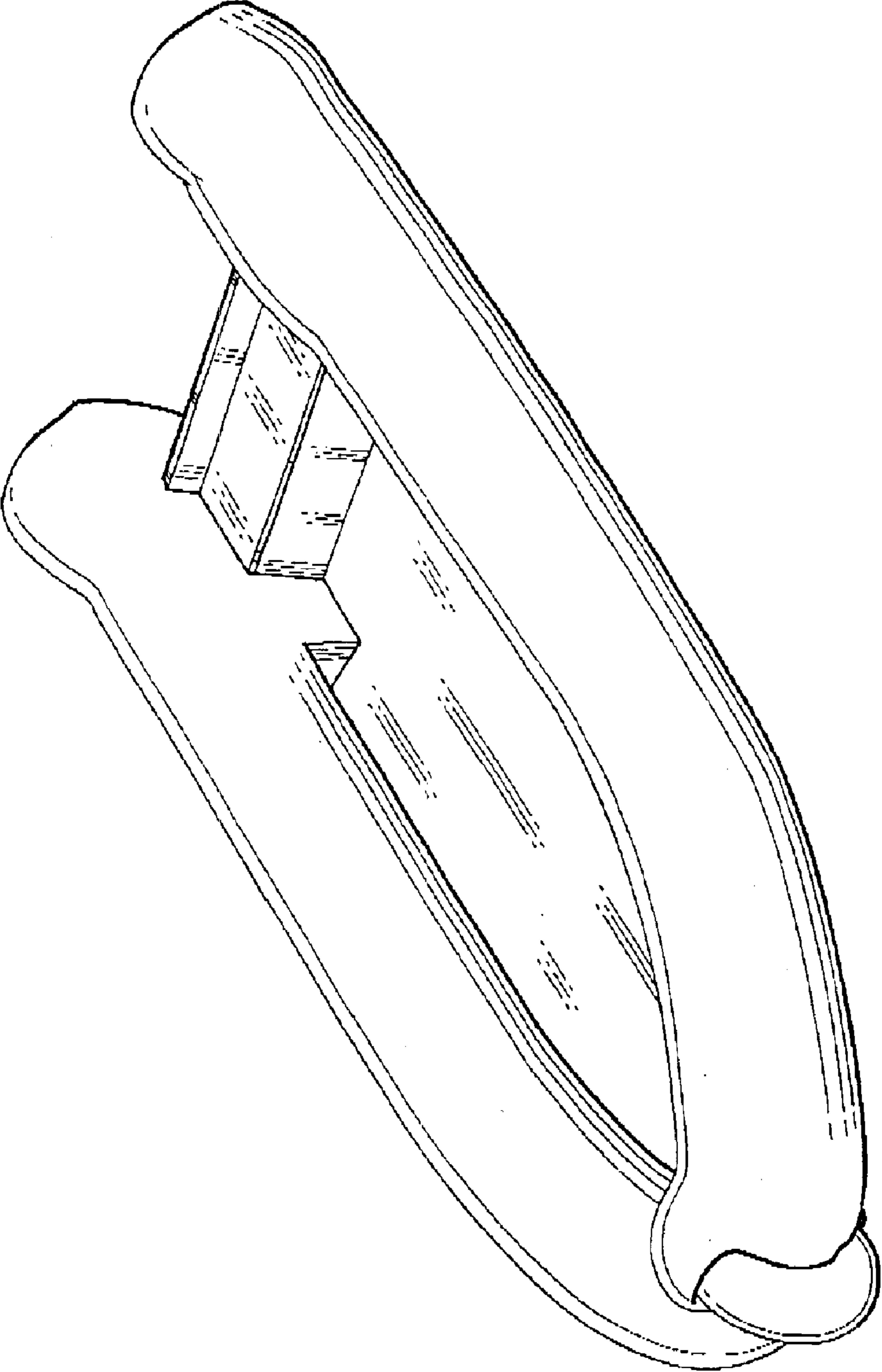

FIG. 13

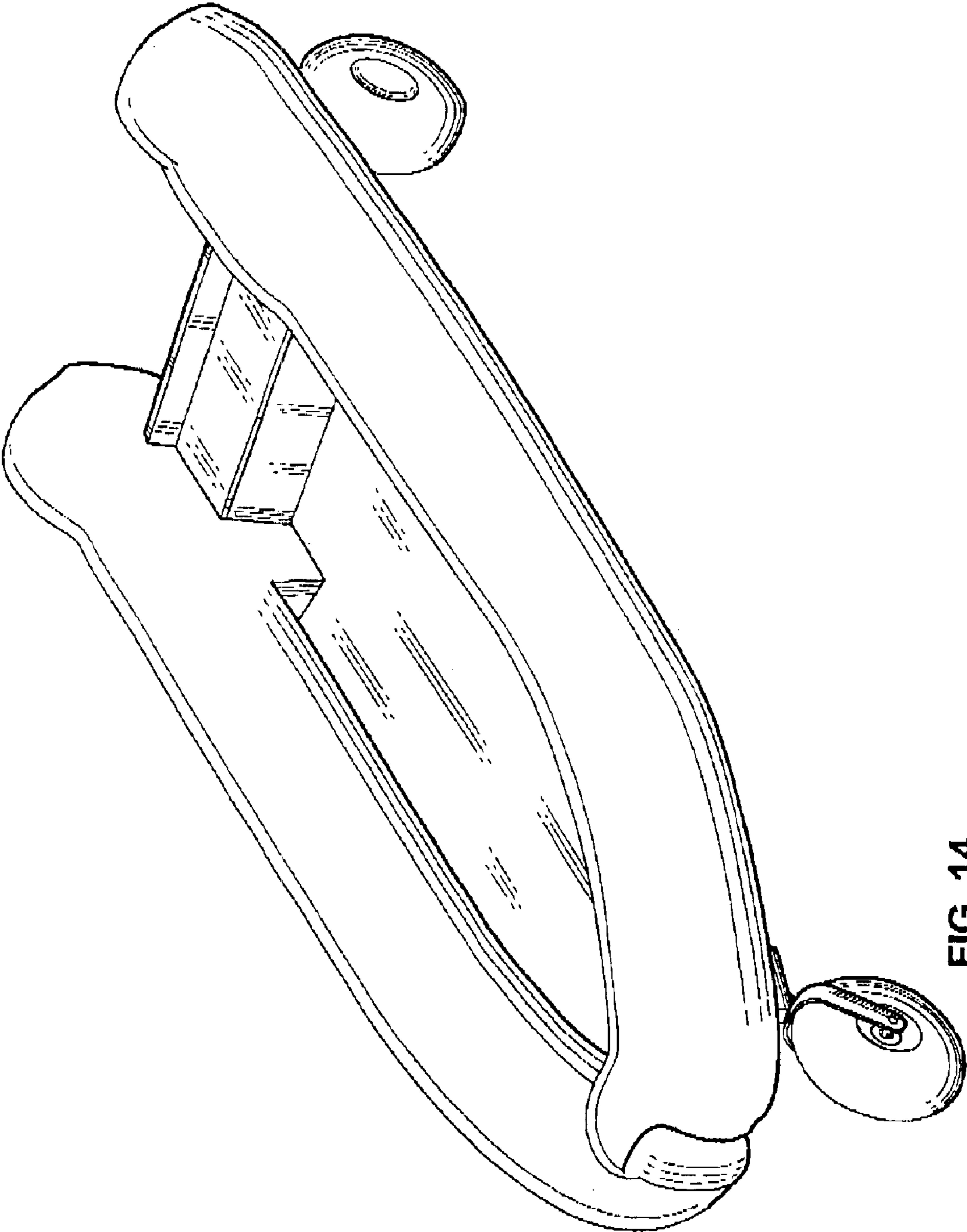

FIG. 14

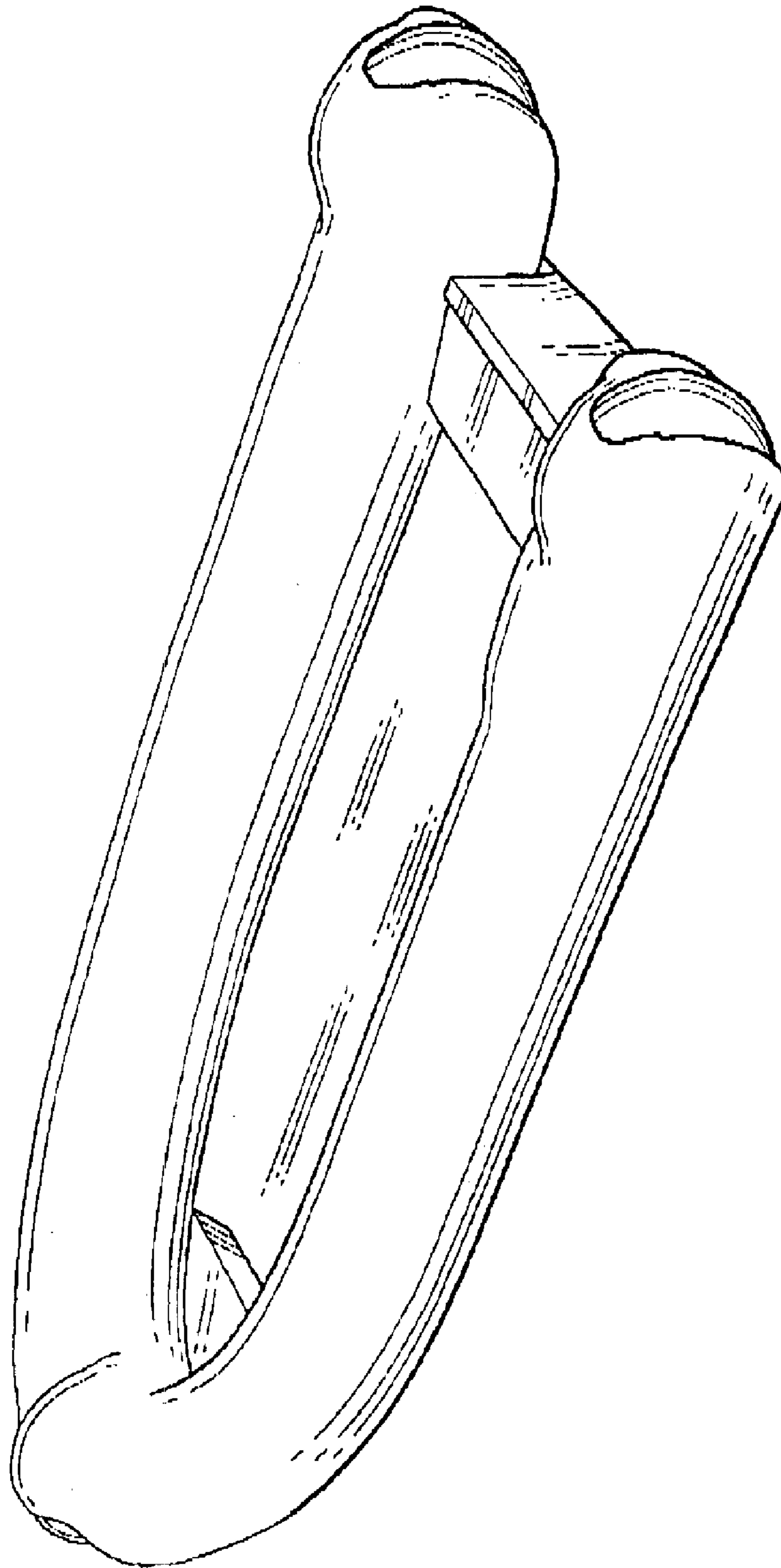

FIG. 15

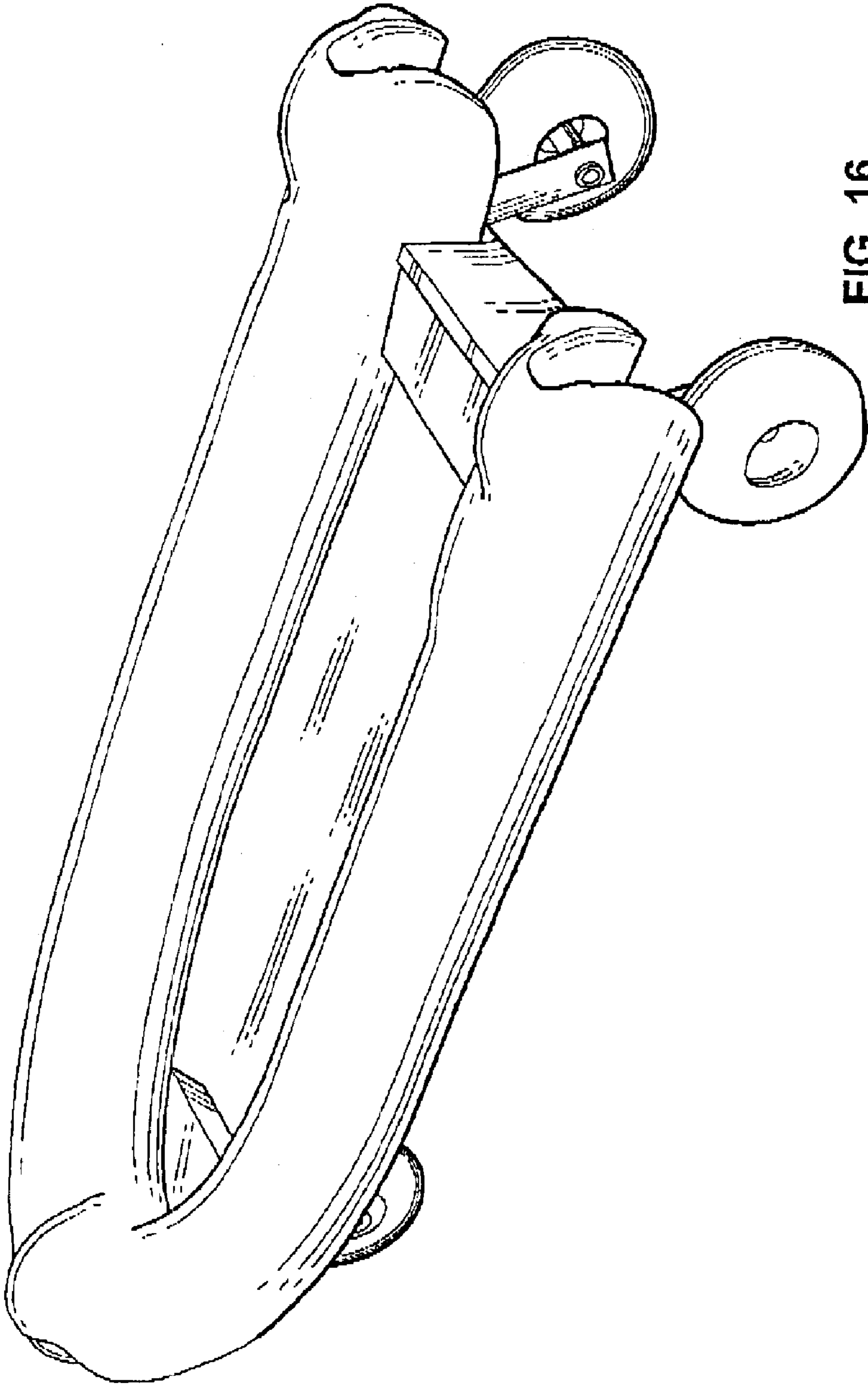

FIG. 16

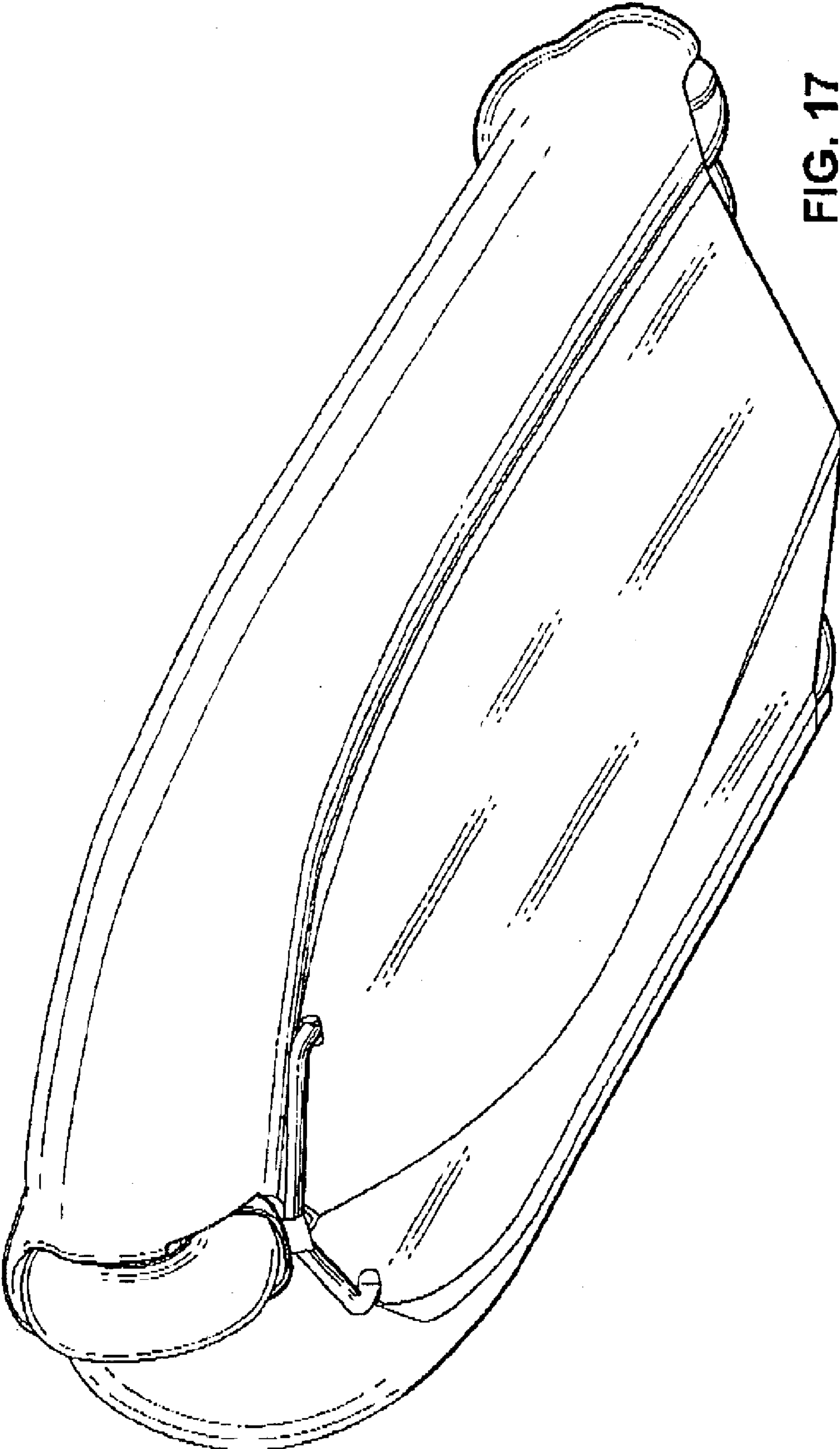

FIG. 17

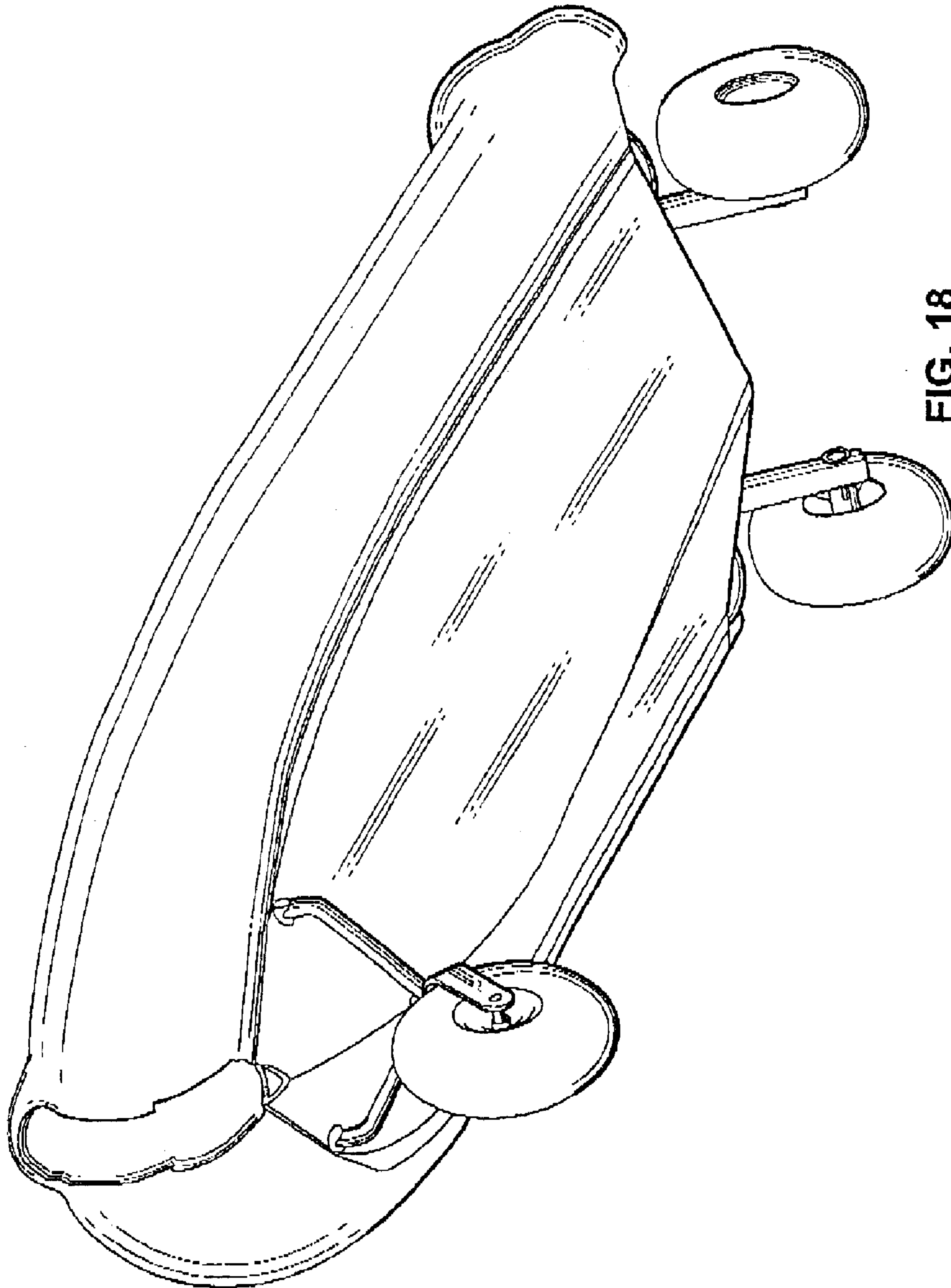

FIG. 18