

US00D505432S

(12) **United States Design Patent**
Antonetti

(10) **Patent No.:** **US D505,432 S**

(45) **Date of Patent:** **** May 24, 2005**

(54) **OFF HIGHWAY MOBILE EQUIPMENT CAB**

(75) Inventor: **Thomas Antonetti**, Fresno, CA (US)

(73) Assignee: **Saf-T-Cab, Inc.**, Fresno, CA (US)

(**) Term: **14 Years**

(21) Appl. No.: **29/193,785**

(22) Filed: **Nov. 13, 2003**

(51) **LOC (7) Cl.** **15-03**

(52) **U.S. Cl.** **D15/30**

(58) **Field of Search** D15/10, 22-26,
D15/28, 30, 33; 212/291; 180/89.1, 89.12,
900; 296/79, 102, 190.08, 190.03

(56) **References Cited**

U.S. PATENT DOCUMENTS

5,273,340	A	*	12/1993	Nelson et al.	296/190.08
D389,984	S	*	1/1998	Johansson	D34/37
D410,472	S	*	6/1999	Hinsperger	D15/30
D415,772	S	*	10/1999	Hinsperger	D15/11
D427,612	S	*	7/2000	Shim	D15/23
D445,233	S	*	7/2001	Deroure	D34/37

OTHER PUBLICATIONS

Website pages by CATERPILLAR re Wheel Loaders; 3 pgs.
Website pages by CATERPILLAR re Compactors; 2 pgs.
Website pages by HAMM re Asphalt Compactors; 2 pgs;
2003.

Website pages by HAMM re Soil Compactors; 1 pg; 2003.
Website pages by Construction Machinery Industrial, LLC
re Compact Wheel Loaders; 1 pg.

Website pages by MANITOU re Maniscopic MT 5-10; 2
pgs.

Brochure by KOBELCO re Dynamic Acera Hydraulic Exca-
vator; 9 pgs; 2003.

Brochure by John Deere re Telehandlers; 16 pgs.

Brochure by JLG re Telescopic Handlers; 6 pgs.

Photographs of Ingersall Rand Road Machinery; 2 photos on
1pg; May 2003.

* cited by examiner

Primary Examiner—Mitchell Siegel

(74) *Attorney, Agent, or Firm*—Mark D. Miller

(57) **CLAIM**

I claim the ornamental design for an off highway mobile
equipment cab, as shown.

DESCRIPTION

FIG. 1 is a front perspective view of the off highway mobile
equipment cab showing my new design;
FIG. 2 is a front elevational view thereof;
FIG. 3 is a rear elevational view thereof;
FIG. 4 is a top plan view thereof;
FIG. 5 is a bottom plan view thereof;
FIG. 6 is a left side elevational view thereof;
FIG. 7 is a left side perspective view showing the door and
windows in a partially opened condition; and,
FIG. 8 is a right side elevational view thereof.

1 Claim, 8 Drawing Sheets

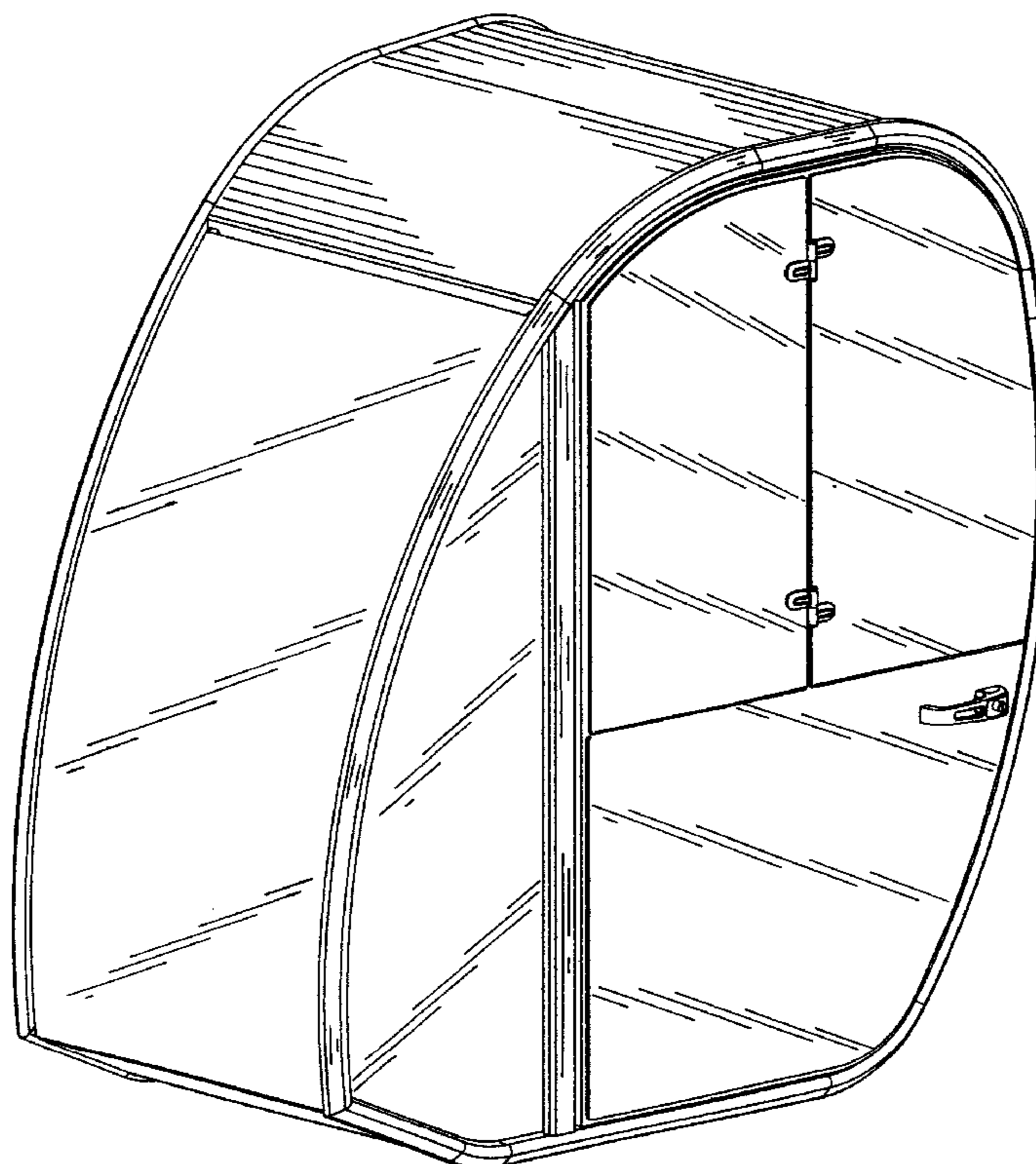

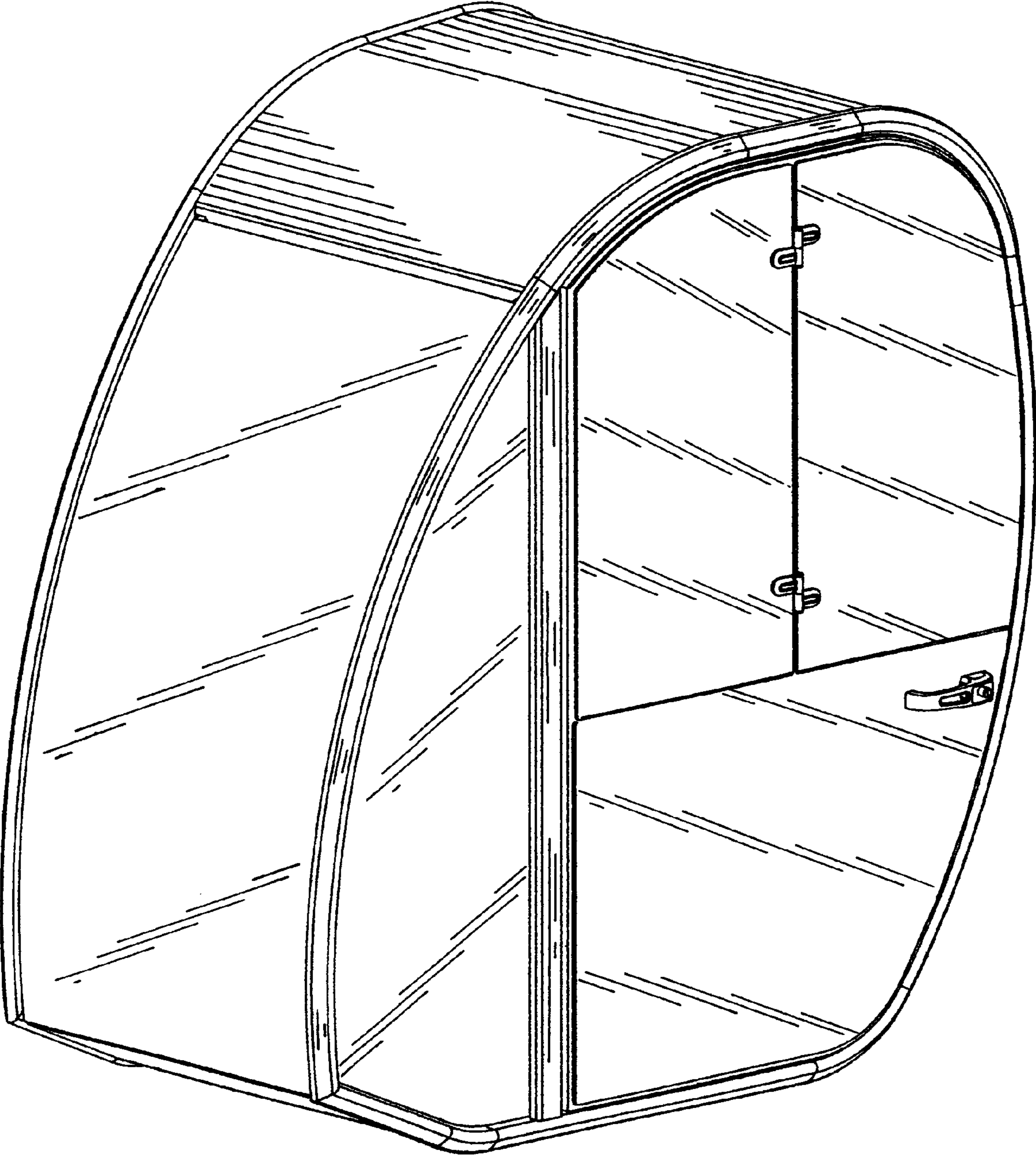

FIG. 1

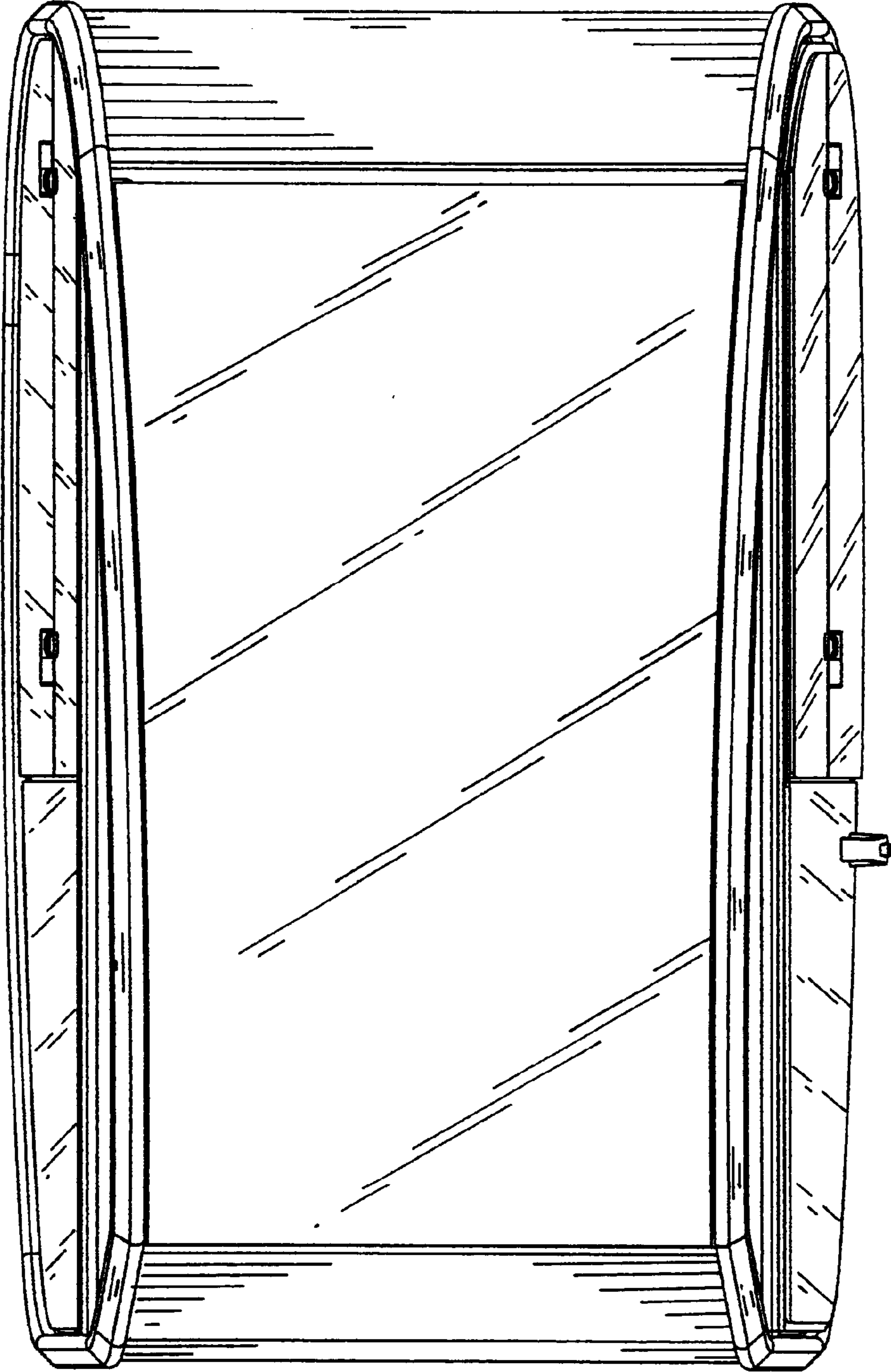

FIG. 2

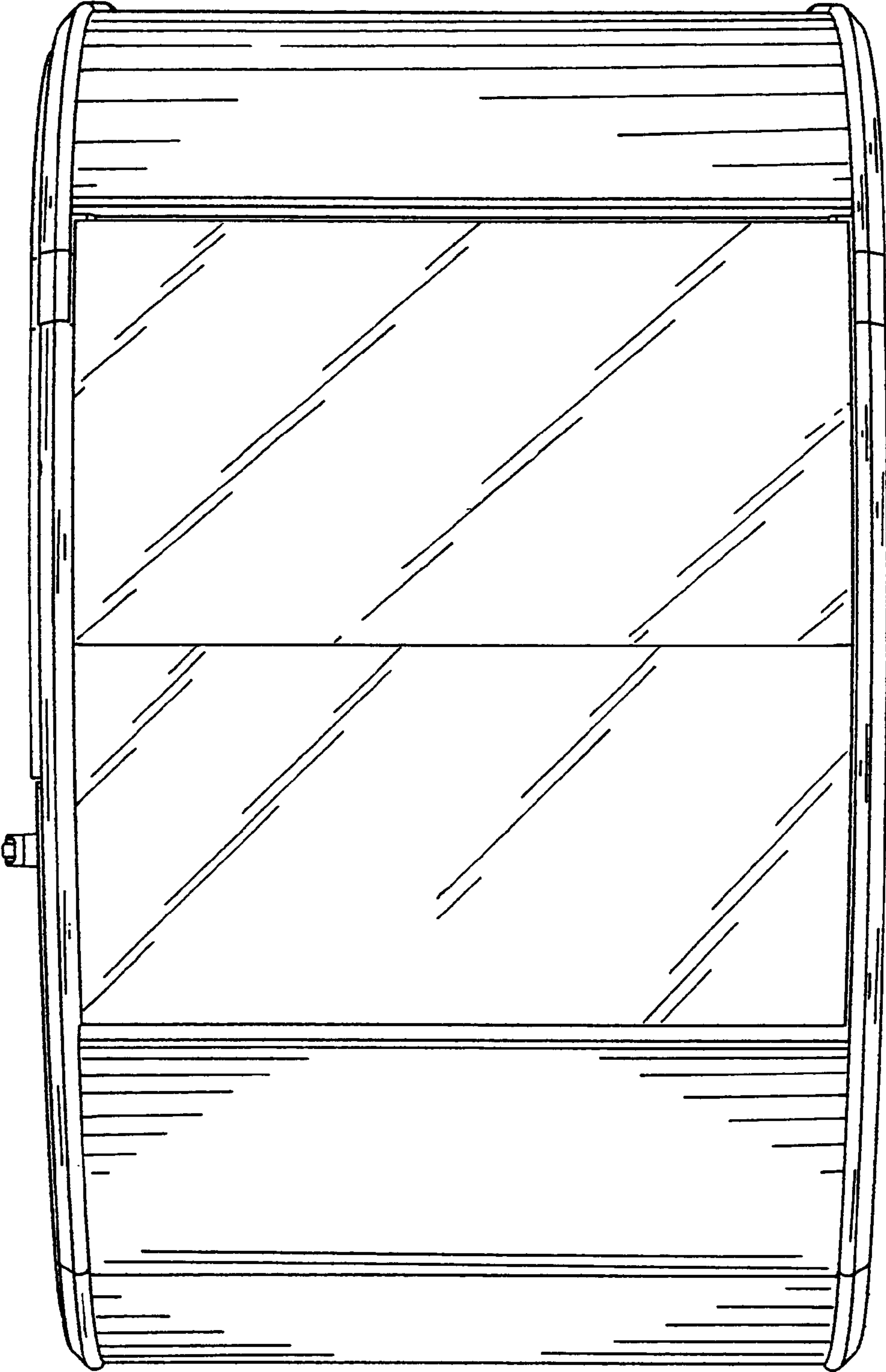

FIG. 3

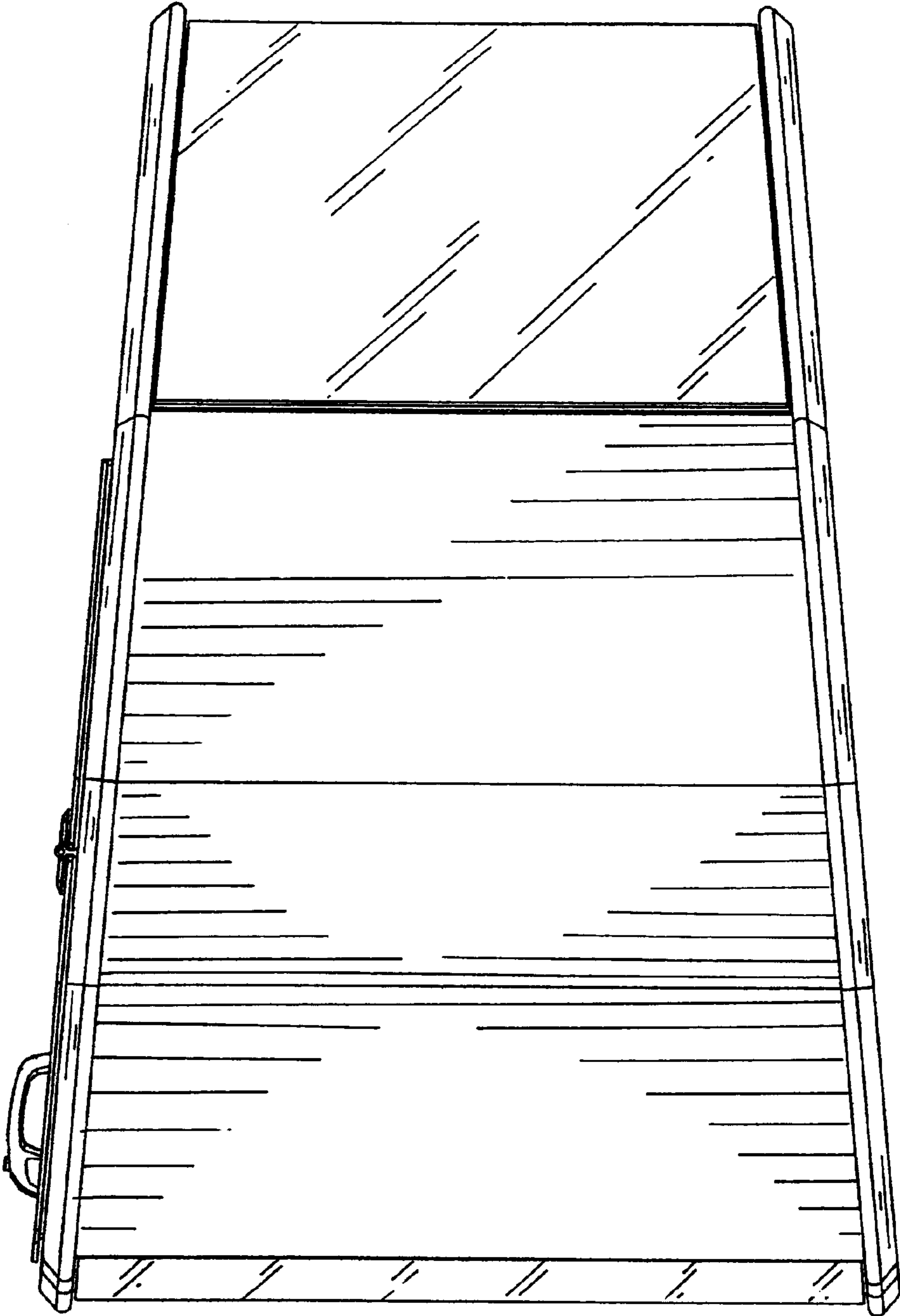

FIG. 4

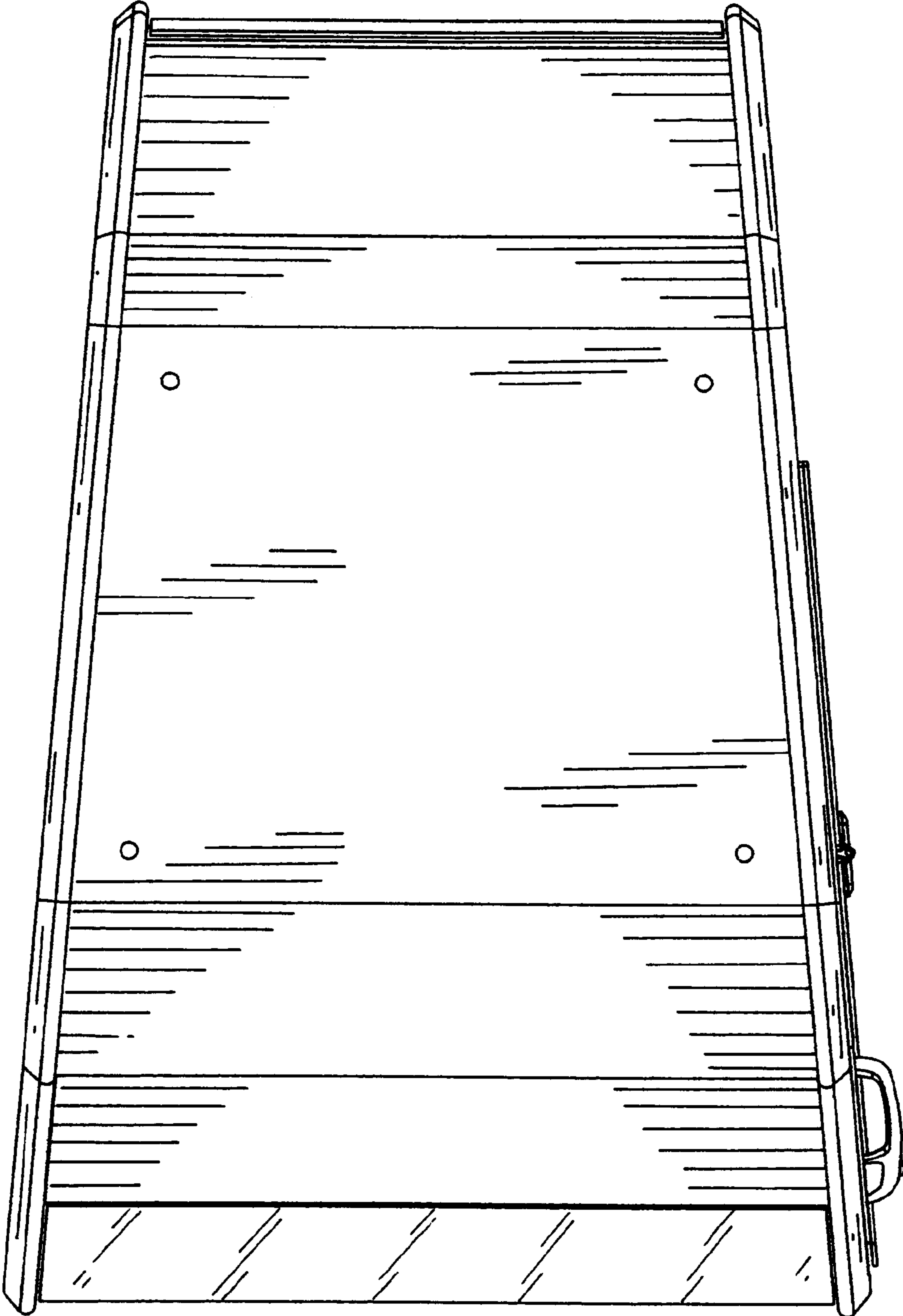

FIG. 5

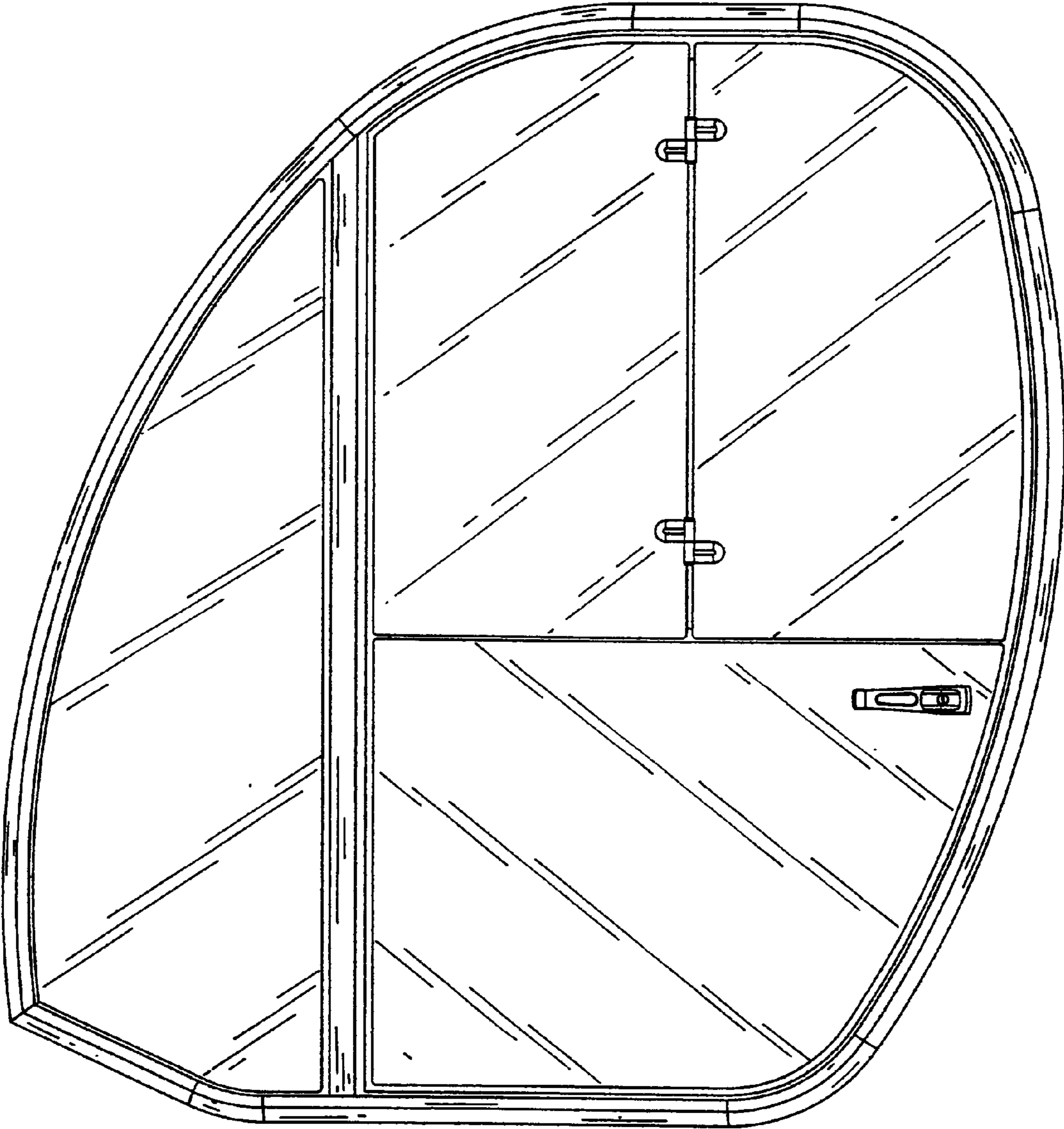

FIG. 6

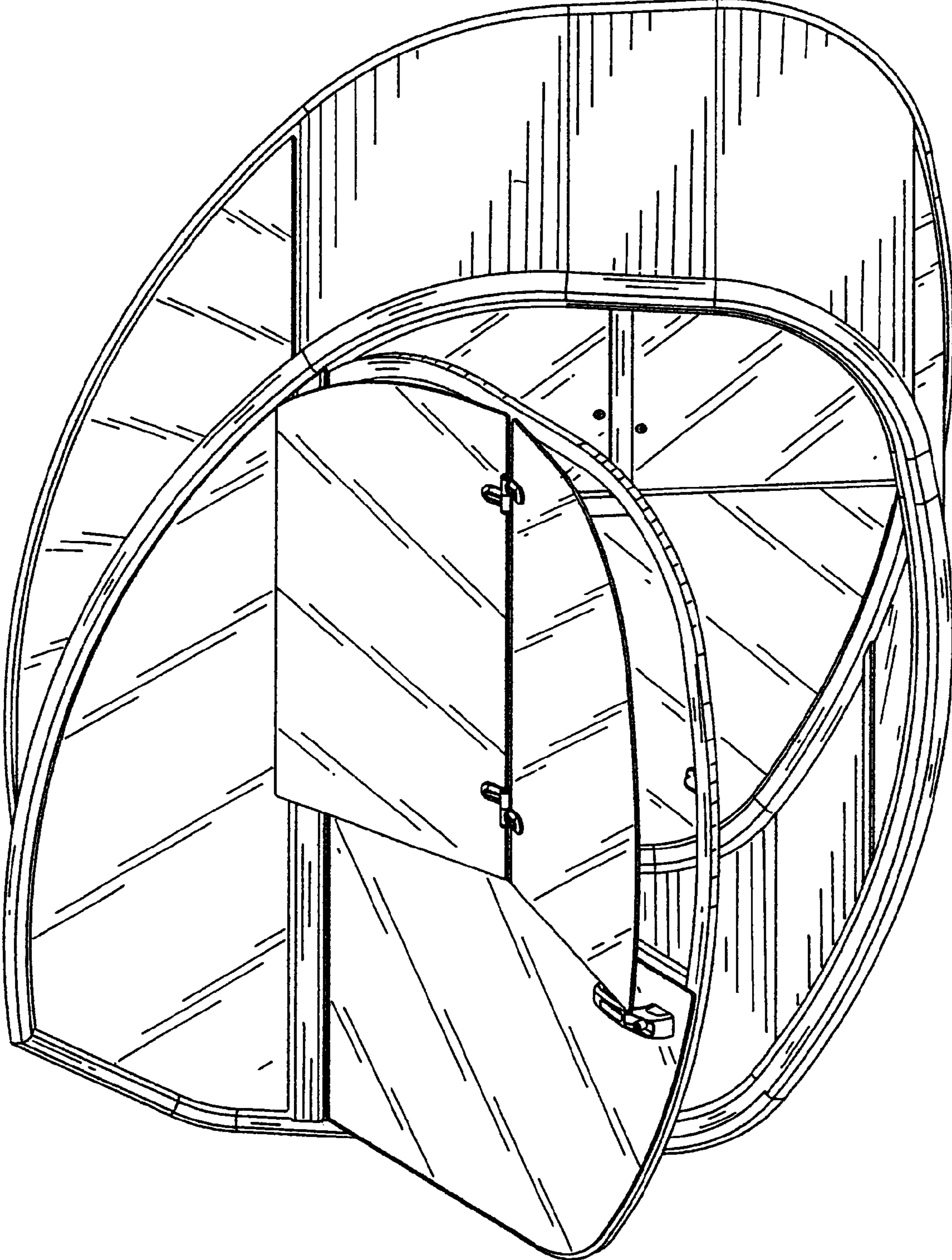

FIG. 7

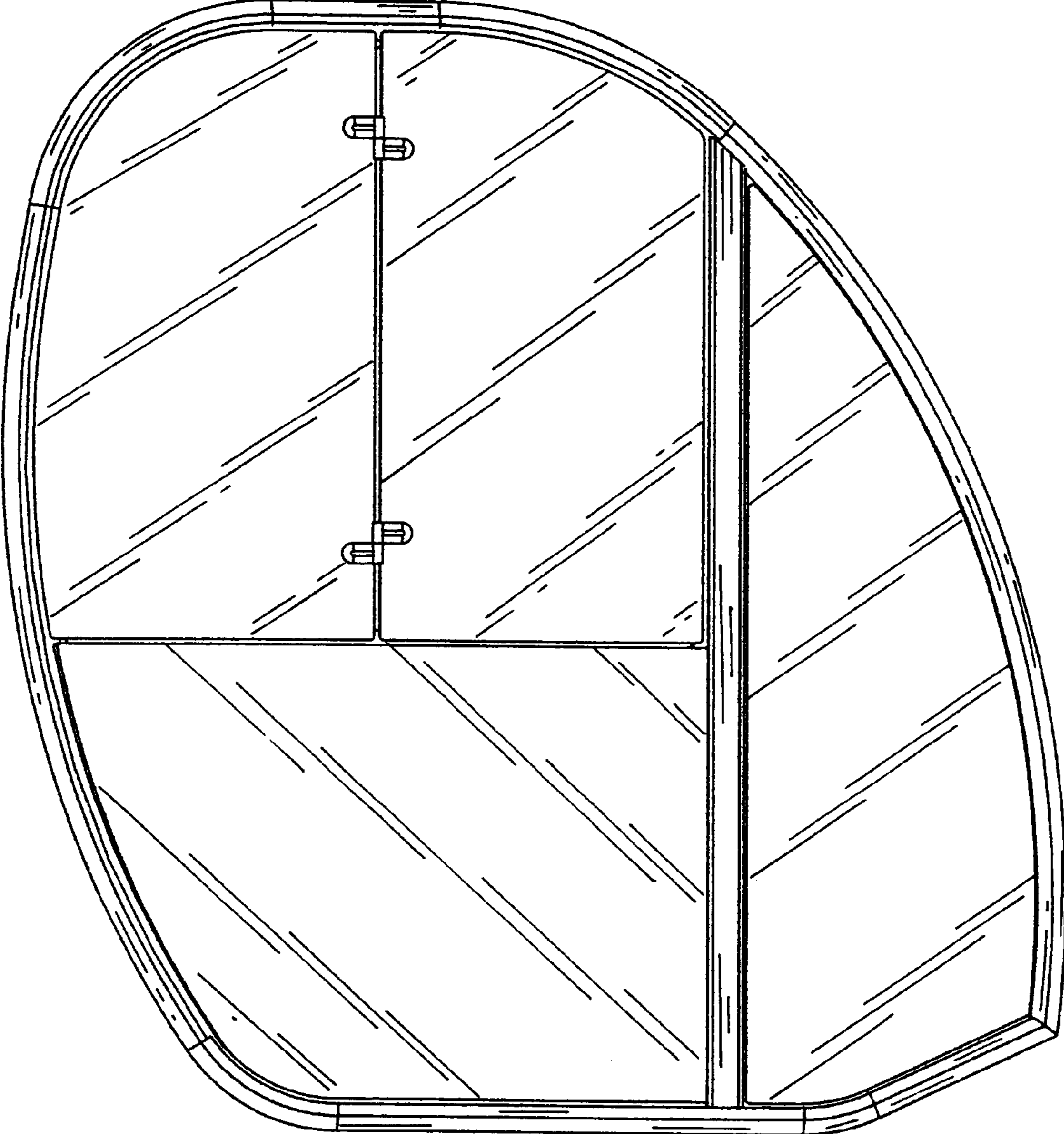

FIG. 8