

US00D505419S

(12) **United States Design Patent**
Hashi et al.

(10) **Patent No.: US D505,419 S**
(45) **Date of Patent: ** May 24, 2005**

(54) **MAGNETIC HEAD SUSPENSION**

6,571,455 B2 * 6/2003 Takagi et al. 360/244.2

(75) Inventors: **Hideyuki Hashi**, Osaka (JP); **Hideki Kuwajima**, Kyoto (JP)

FOREIGN PATENT DOCUMENTS

(73) Assignee: **Matsushita Electric Industrial Co., Ltd.**, Osaka (JP)

JP	1005527	7/1998
JP	1070660	5/2000
JP	1070938	5/2000

(**) Term: **14 Years**

* cited by examiner

(21) Appl. No.: **29/178,539**

Primary Examiner—Nanda Bondade
(74) *Attorney, Agent, or Firm*—Christensen O'Connor Johnson Kindness PLLC

(22) Filed: **Mar. 25, 2003**

(30) **Foreign Application Priority Data**

Sep. 26, 2002 (JP) 2002-026344

(57) **CLAIM**

The ornamental design for a magnetic head suspension, as shown and described.

(51) **LOC (7) Cl.** **14-99**

DESCRIPTION

(52) **U.S. Cl.** **D14/260**

(58) **Field of Search** D14/156, 217, D14/239, 260, 260.1, 262, 264; 242/333.6, 356; 360/244.6, 245, 245.1, 245.5, 245.9, 264.4, 244.8, 265.7, 294.7; 29/603.03, 603.04; 369/13.17

FIG. 1 is a perspective view of the top, rear and left side of a magnetic head suspension showing our new design; FIG. 2 is a front view thereof; FIG. 3 is a rear view thereof; FIG. 4 is a left side view thereof; FIG. 5 is a right side view thereof; FIG. 6 is a top plan view thereof; and, FIG. 7 is a bottom view thereof.

(56) **References Cited**

U.S. PATENT DOCUMENTS

5,446,611 A *	8/1995	Webber	360/245
5,600,515 A *	2/1997	Mizuno et al.	369/13.17
D398,613 S *	9/1998	Kurita et al.	D14/260
D437,846 S *	2/2001	Kabasawa et al.	D14/260
6,362,938 B1 *	3/2002	Suzuki et al.	360/294.4

The dot and dash lines which define the bounds of the claimed design form no part thereof. The portions of the article in broken lines are shown for illustrative purposes only and form no part of the claimed design.

1 Claim, 3 Drawing Sheets

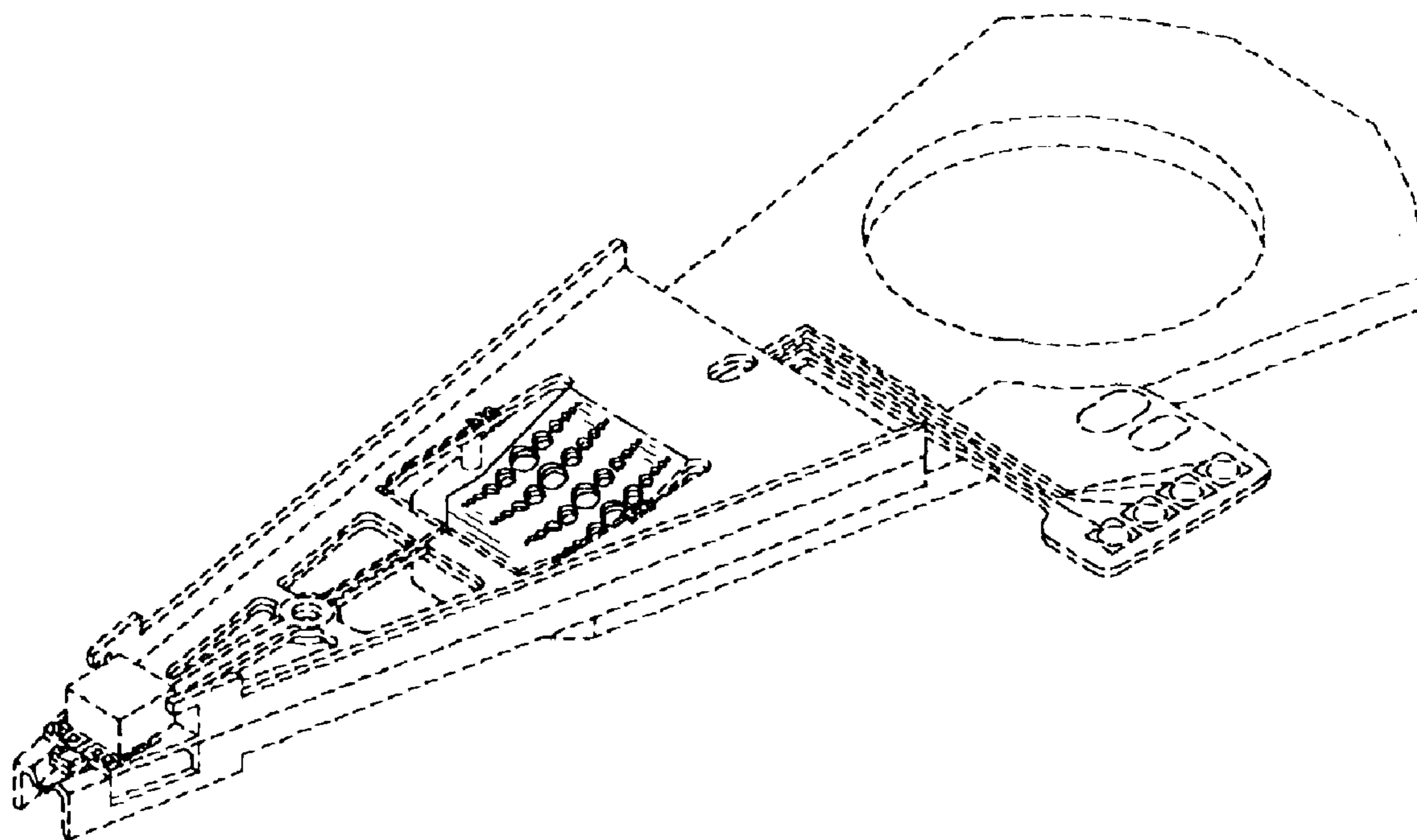

FIG. 1

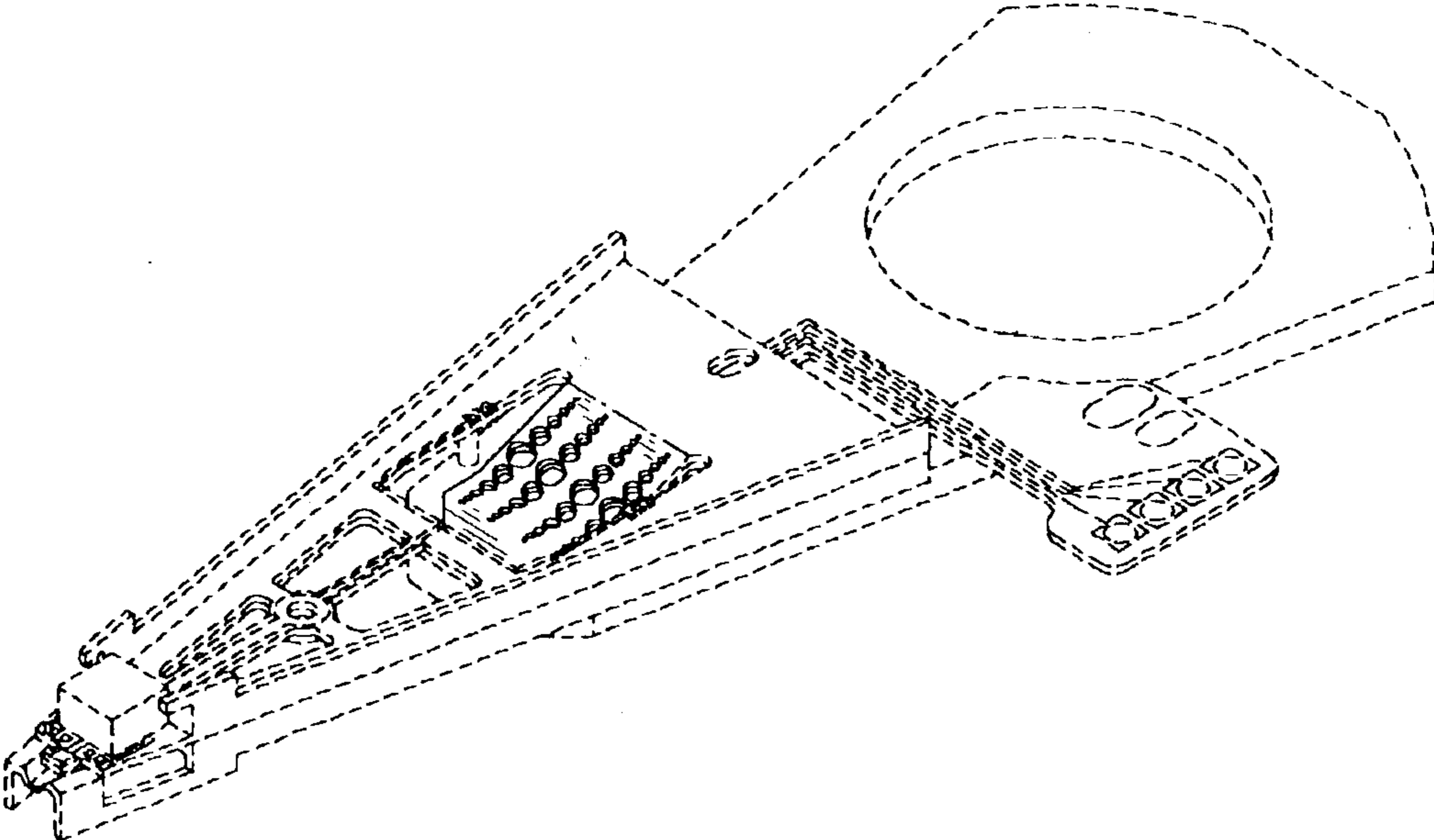

FIG. 2

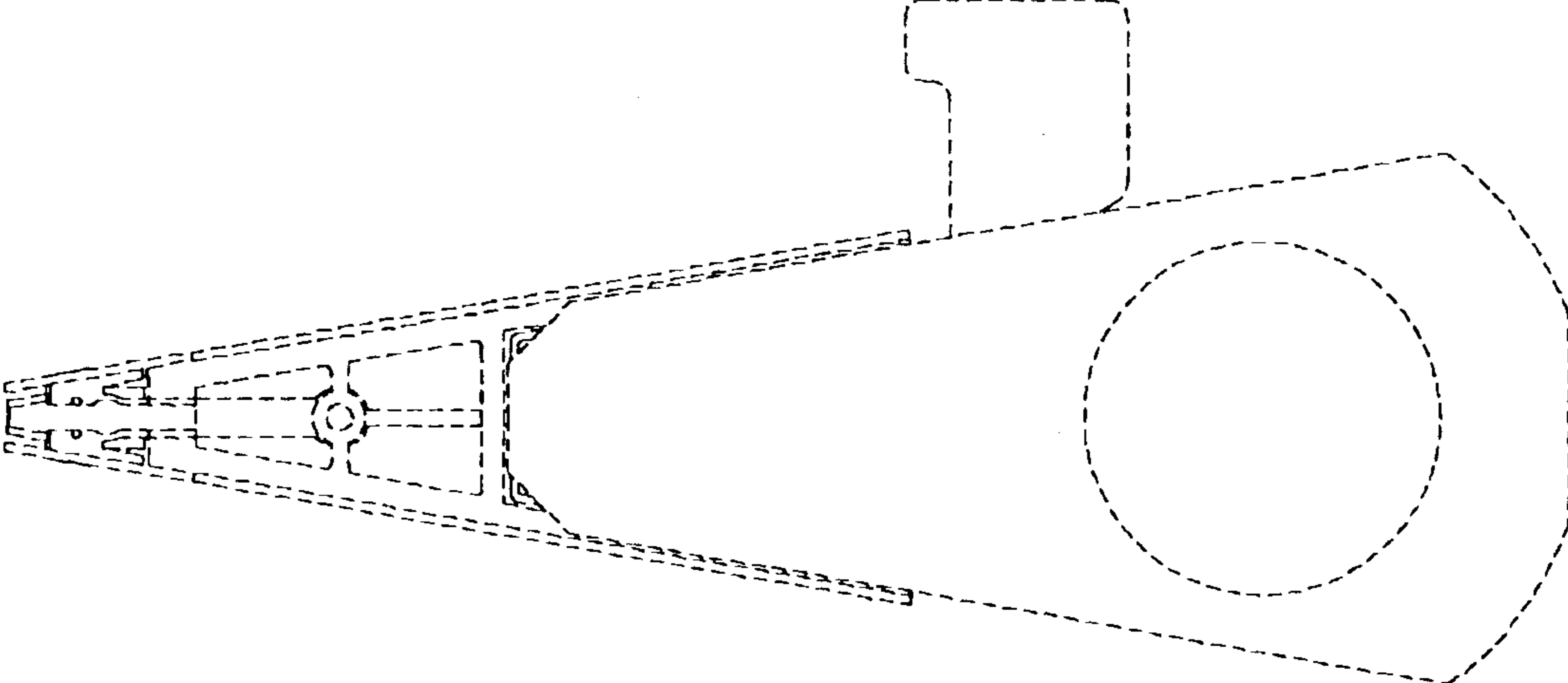

FIG. 3

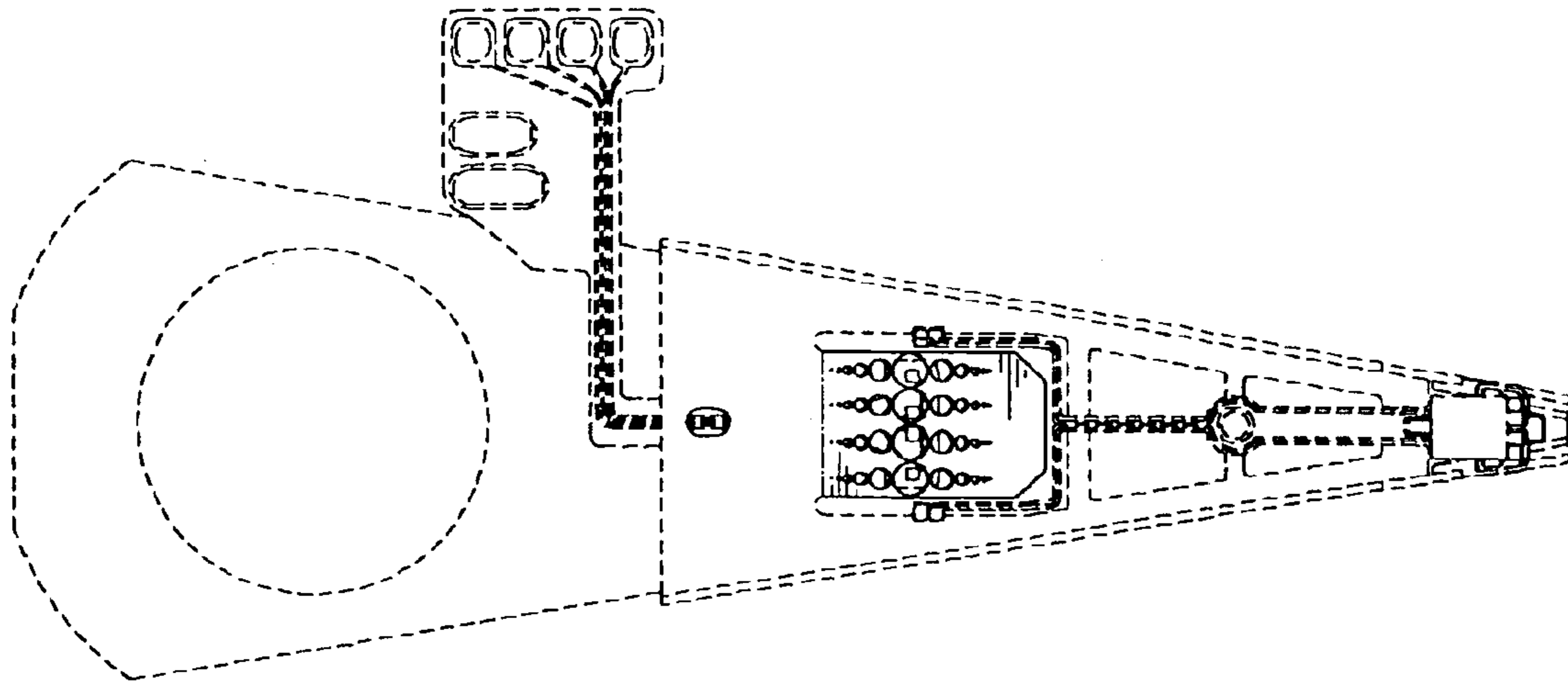

FIG. 4



FIG. 5



FIG. 6

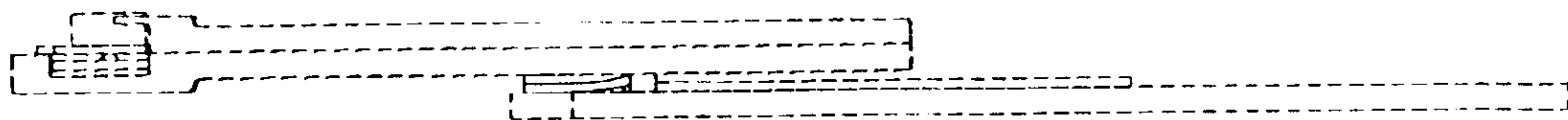

FIG. 7

