

US00D505345S

(12) **United States Design Patent**
Risher

(10) **Patent No.:** **US D505,345 S**

(45) **Date of Patent:** **** May 24, 2005**

(54) **AIM CHALK BOX/LAYOUT ASSISTANT**

6,578,274 B1 * 6/2003 Tango et al. 33/1 G

(76) **Inventor:** **David Risher**, 1421-D Orchard Lake Dr., Sardis Executive Park, Charlotte, NC (US) 28270

* cited by examiner

Primary Examiner—Joel A. Sincavage

Assistant Examiner—Vy Nguyen

(74) *Attorney, Agent, or Firm*—Whittaker Law Firm; Malcolm E. Whittaker

(**) **Term:** **14 Years**

(21) **Appl. No.:** **29/180,632**

(57) **CLAIM**

(22) **Filed:** **Apr. 28, 2003**

The ornamental design for the AIM chalk box/layout assistant, as shown and described.

(51) **LOC (7) Cl.** **10-04**

(52) **U.S. Cl.** **D10/74**

(58) **Field of Search** D10/70-74; 33/413-414, 33/754-756, 758-761, 770, 1 G

DESCRIPTION

FIG. 1 is a perspective view of the present invention. FIG. 2 is a top plan view of the present invention. FIG. 3 is a right side view of the present invention. FIG. 4 is a bottom plan view of the present invention. FIG. 5 is a left side view of the present invention. FIG. 6 front view of the present invention; and, FIG. 7 is a rear view of the present invention.

(56) **References Cited**

U.S. PATENT DOCUMENTS

3,122,836 A *	3/1964	Aciego	33/413
3,662,471 A *	5/1972	Lynde	33/770
5,873,174 A *	2/1999	Kraft	33/758
6,295,739 B1 *	10/2001	Kraft	33/758

1 Claim, 3 Drawing Sheets

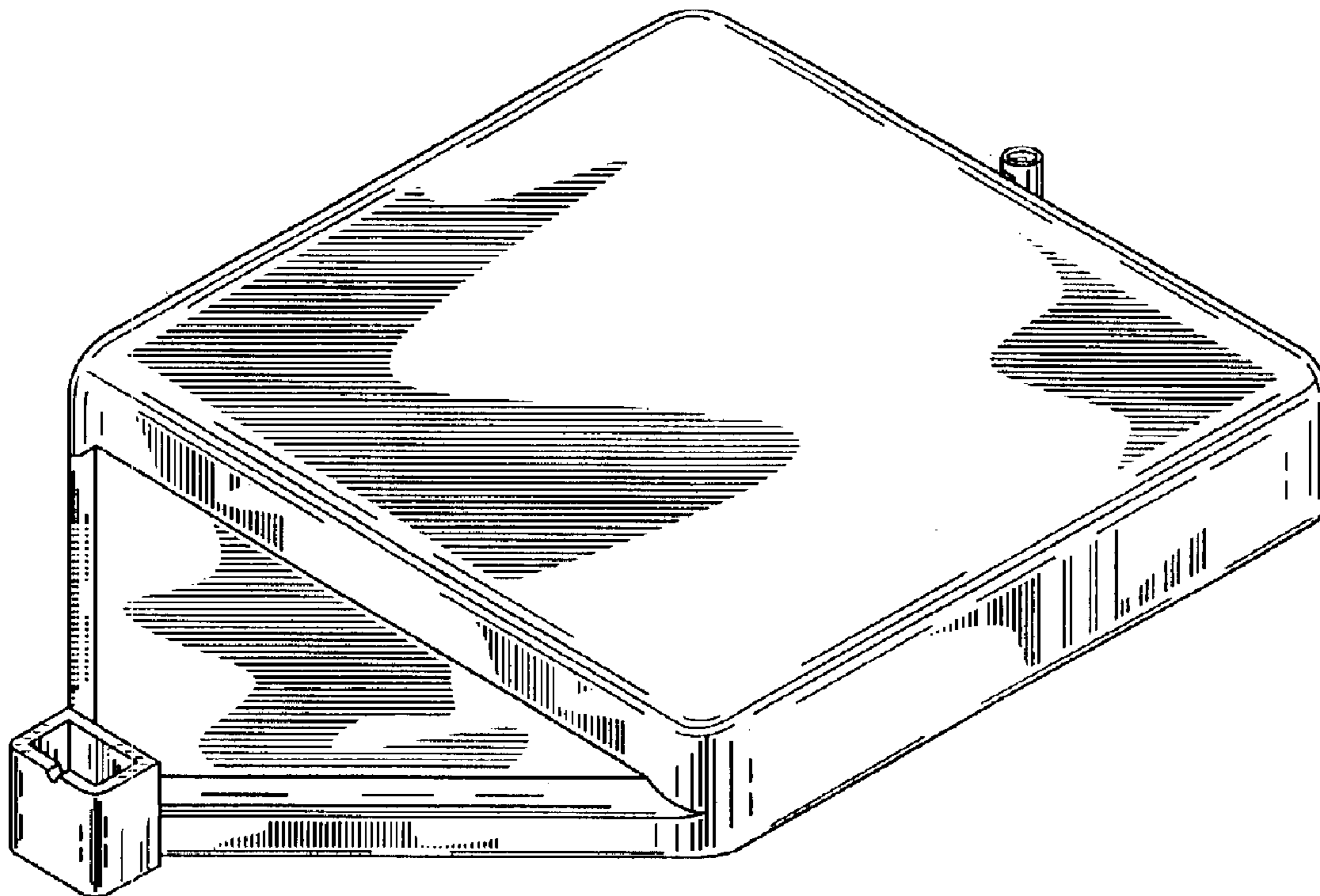

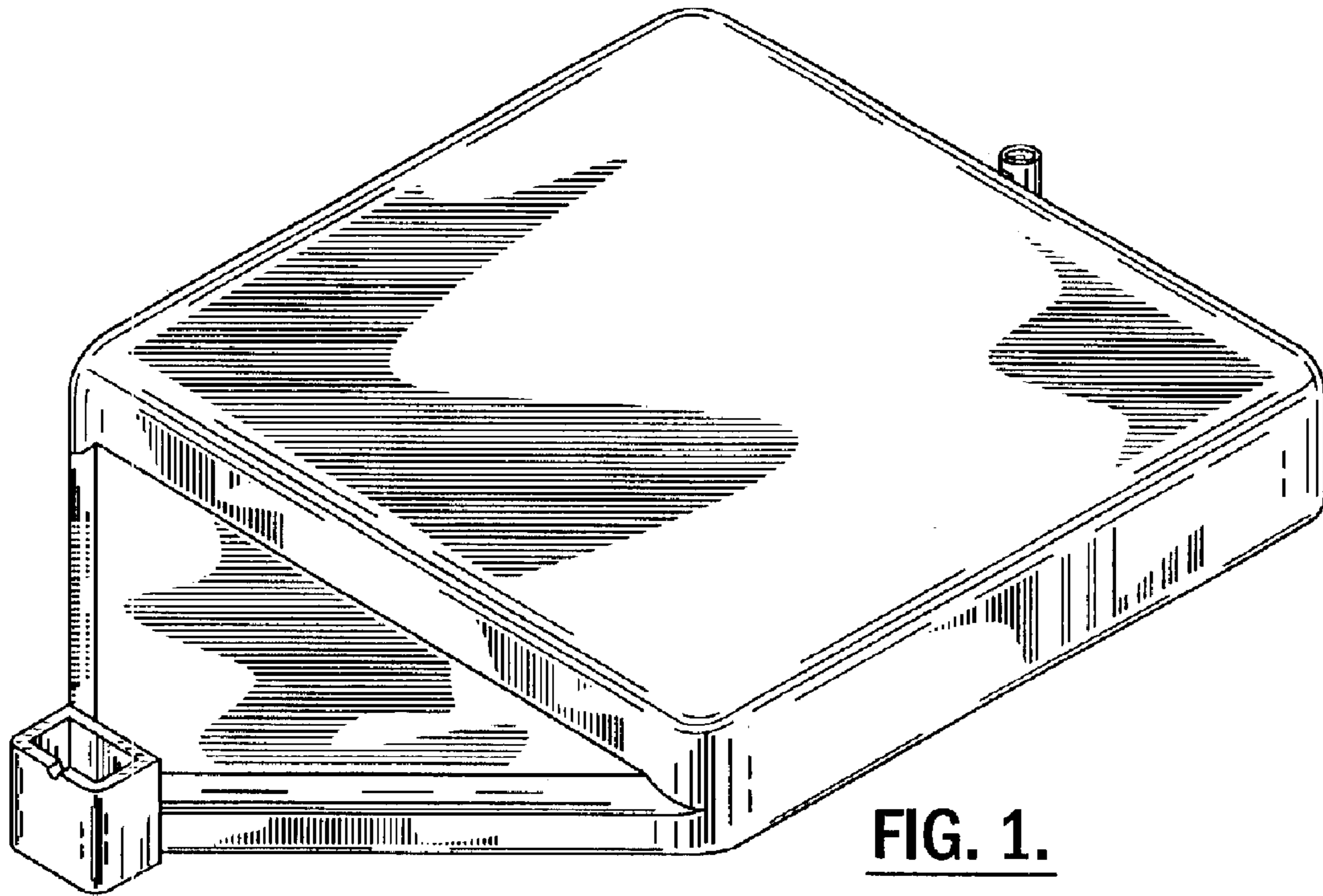

FIG. 1.

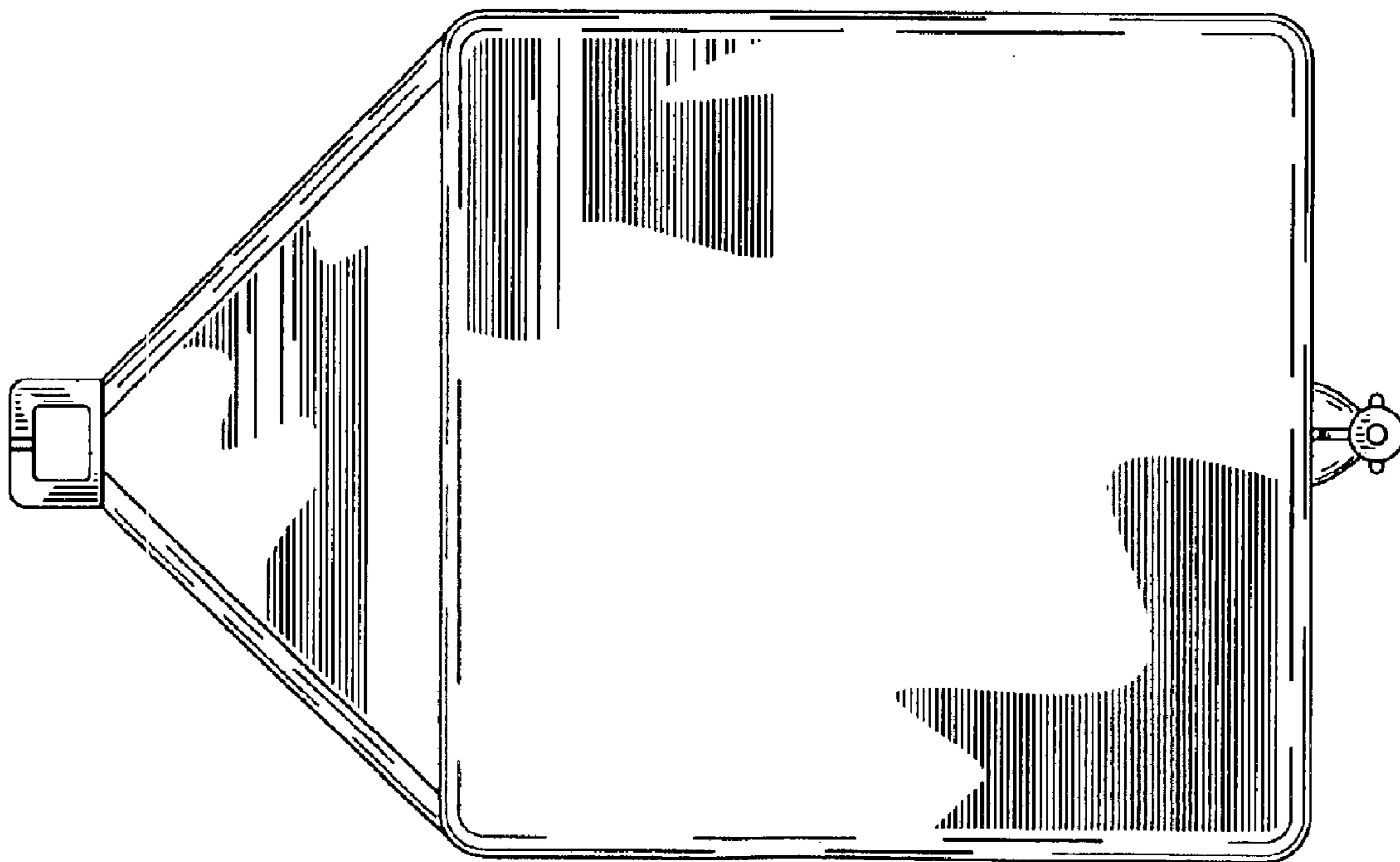

FIG. 2.



FIG. 3.

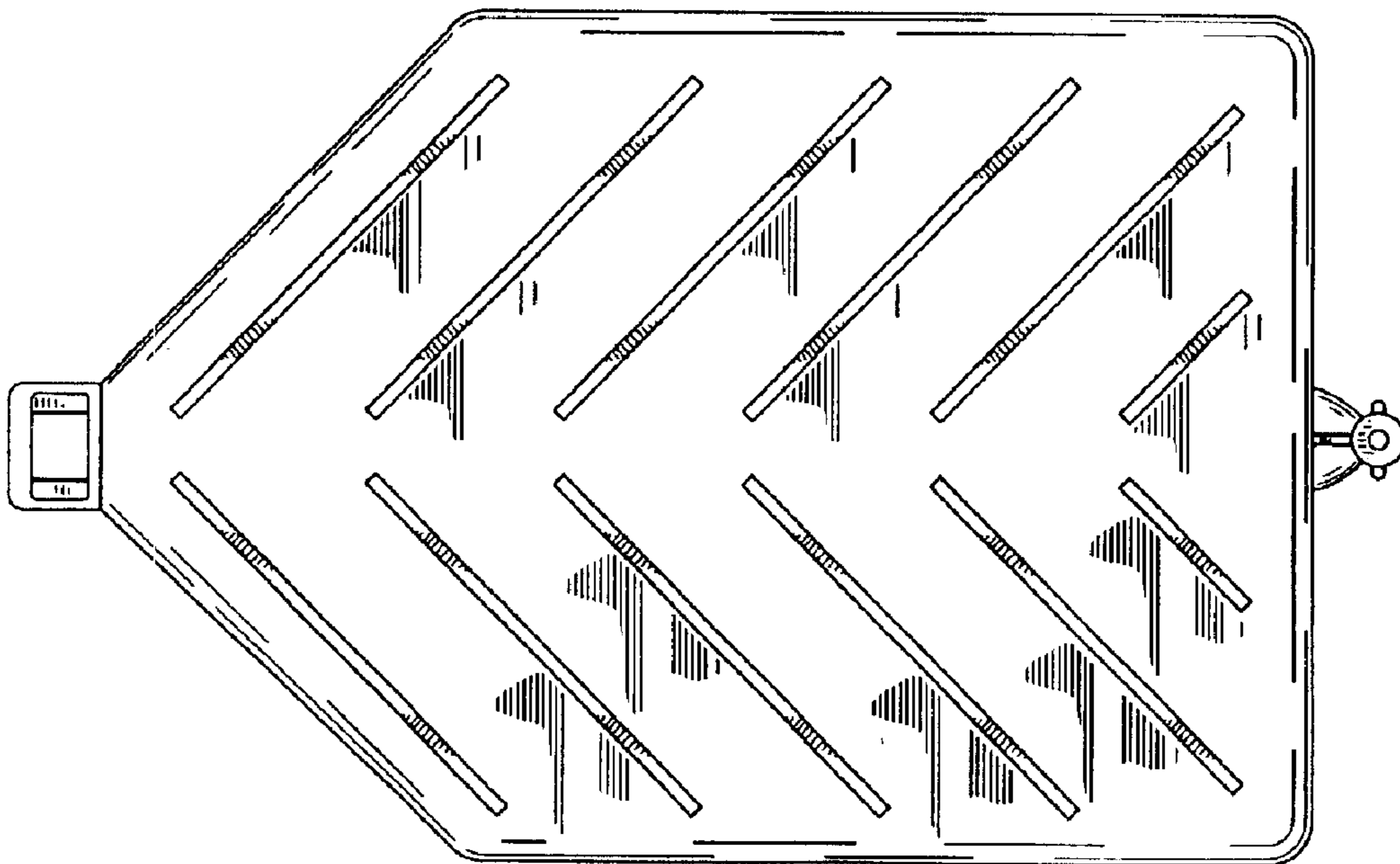

FIG. 4.

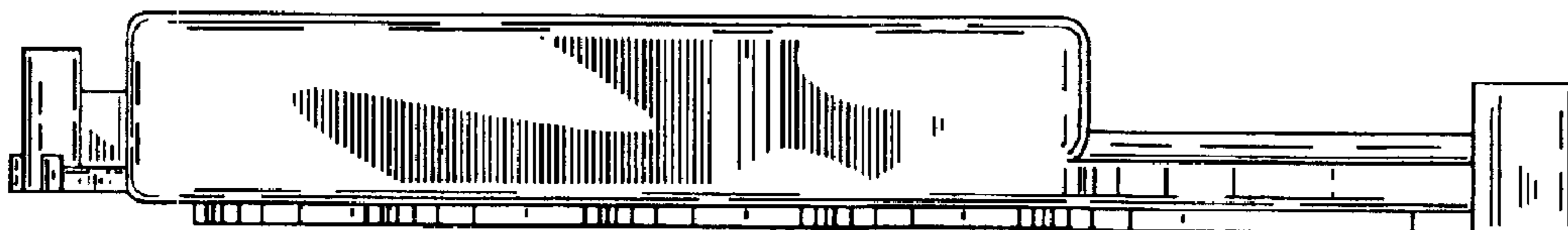

FIG. 5.

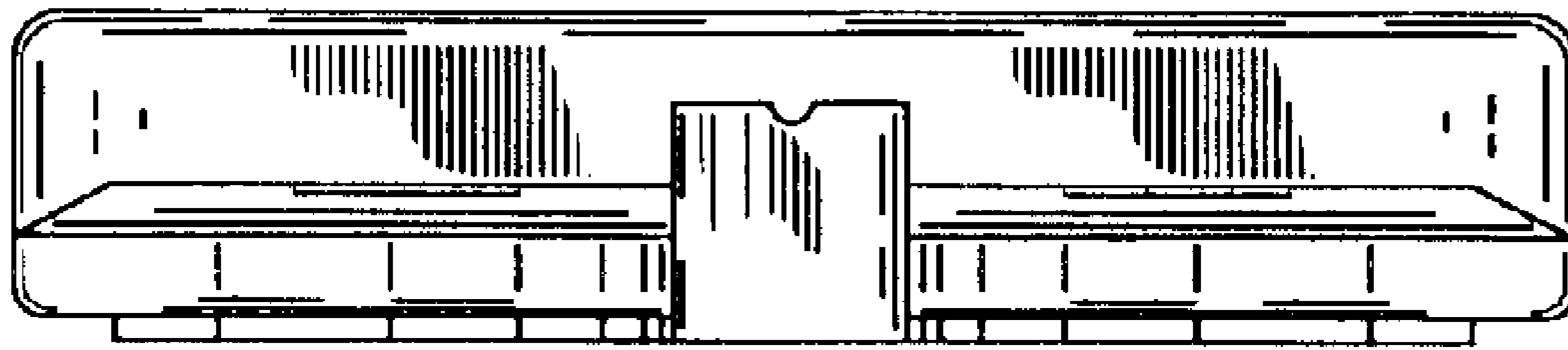

FIG. 6.

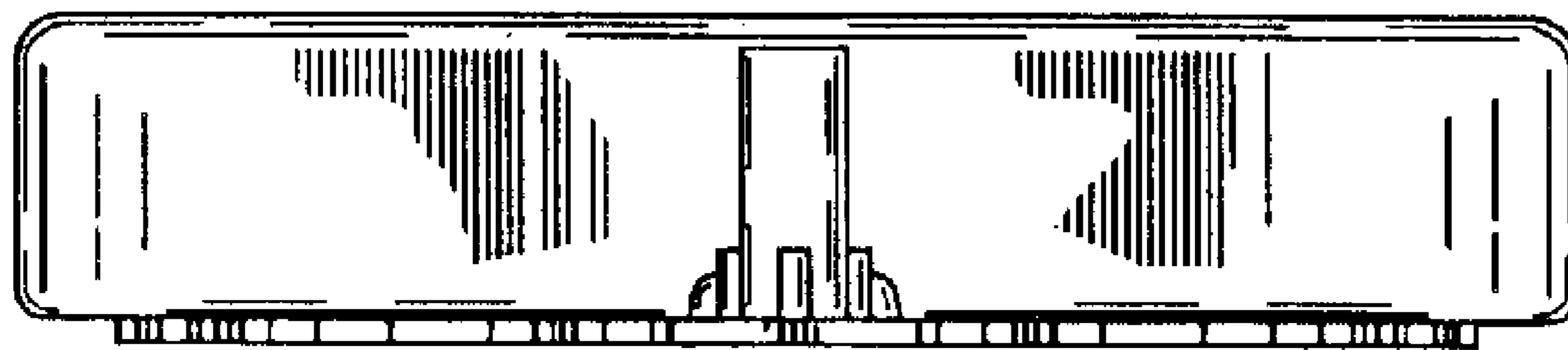

FIG. 7.