

US00D505211S

(12) **United States Design Patent**  
**Stanchfield**

(10) **Patent No.:** **US D505,211 S**  
(45) **Date of Patent:** **\*\* May 17, 2005**

(54) **LAMINATE STAIRNOSE MOLDING**

**FOREIGN PATENT DOCUMENTS**

- (75) Inventor: **Oliver Stanchfield**, Raleigh, NC (US)
- (73) Assignee: **Pergo (Europe) AB**, Trelleborg (SE)
- (\*\*) Term: **14 Years**
- (21) Appl. No.: **29/208,499**
- (22) Filed: **Jun. 30, 2004**

DE	3640822	6/1988
DE	467150	6/1992
DE	29703962	4/1997
DE	19821938	11/1999
DE	10131248	1/2003
WO	9612857	5/1996
WO	9901628	1/1999
WO	0120101	3/2001
WO	03093686	11/2003

**Related U.S. Application Data**

- (60) Division of application No. 10/347,489, filed on Jan. 21, 2003, which is a continuation-in-part of application No. 09/986,414, filed on Nov. 8, 2001, now abandoned.
- (51) **LOC (7) Cl.** ..... **25-01**
- (52) **U.S. Cl.** ..... **D25/119; D25/69**
- (58) **Field of Search** ..... **D25/69, 119; 52/100, 52/461, 464, 288.1, 506.05, 179, 181**

*Primary Examiner*—Doris Clark

(74) *Attorney, Agent, or Firm*—Stevens, Davis, Miller & Mosher, L.L.P.

(57) **CLAIM**

The ornamental design for a laminate stairnose molding, as shown and described.

**DESCRIPTION**

FIG. 1 is a top perspective view of the laminate stairnose molding;  
 FIG. 2 is a side perspective view of the laminate stairnose molding;  
 FIG. 3 is a bottom view of the laminate stairnose molding;  
 and,  
 FIG. 4 is a side view of the laminate stairnose molding, the opposite end view being a mirror image thereof.  
 It should be understood that the laminate transition molding of the present drawings is an indeterminate length, which may be cut to a length as needed; the length shown in FIGS. 1-4 is for convenience of illustration.

(56) **References Cited**

**U.S. PATENT DOCUMENTS**

1,357,713	A	11/1920	Lane
2,100,238	A	11/1937	Burgess
2,194,086	A	3/1940	Horn
2,363,429	A	11/1944	Lowry
3,162,906	A	12/1964	Dudley
3,199,258	A	8/1965	Jentoft et al.
3,286,425	A	11/1966	Brown

(Continued)

**1 Claim, 1 Drawing Sheet**

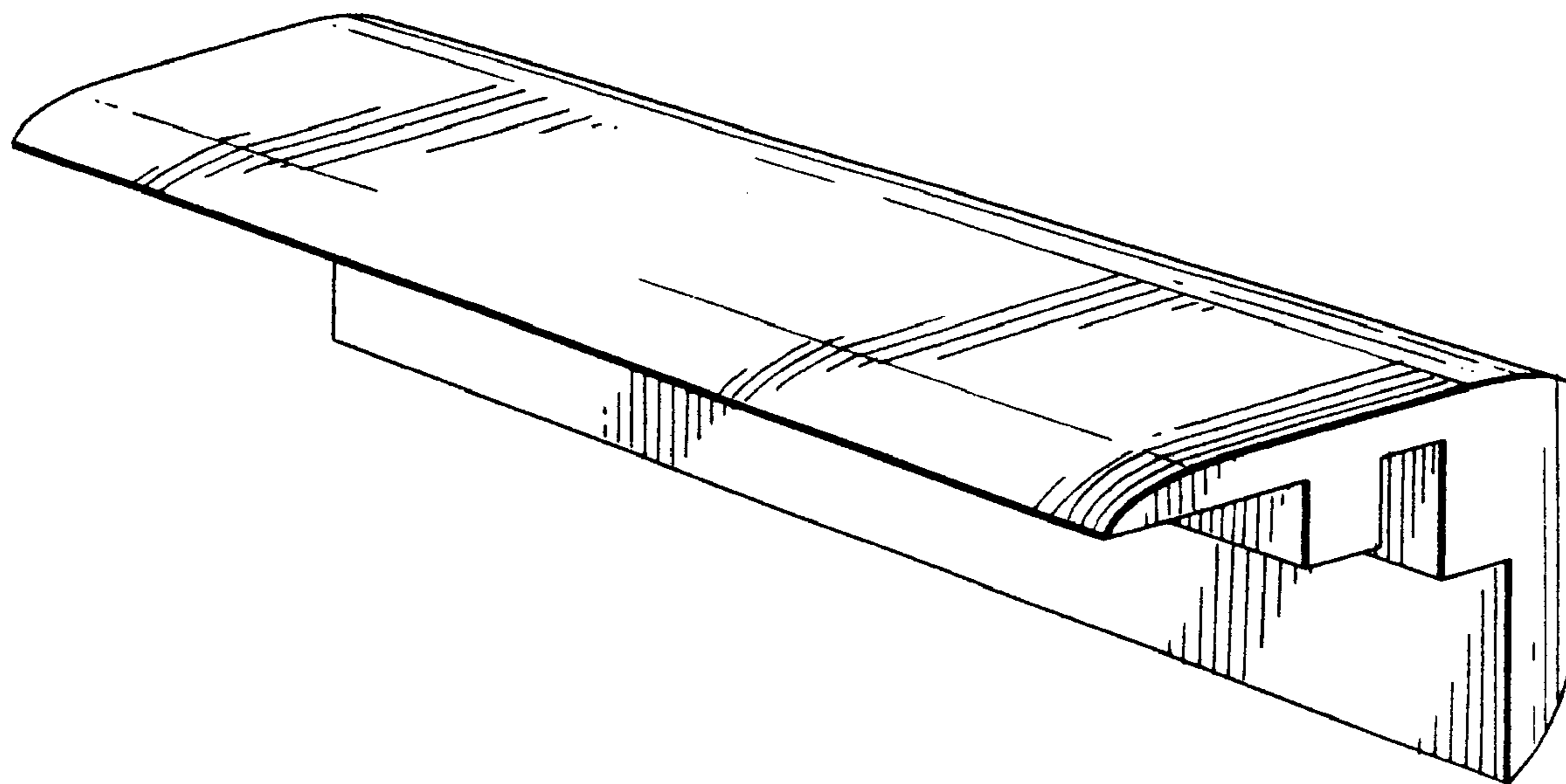

# US D505,211 S

Page 2

## U.S. PATENT DOCUMENTS

3,331,171 A	7/1967	Hallock	5,365,713 A	11/1994	Nicholas et al.
3,339,329 A	9/1967	Berg	D373,203 S	8/1996	Kornfalt
3,363,381 A	1/1968	Forrest	5,581,967 A	12/1996	Glatz
3,488,828 A	1/1970	Gallagher	5,888,017 A	3/1999	Corrie
3,665,666 A	5/1972	Delcroix	6,141,920 A	11/2000	Kemper
3,671,369 A	6/1972	Kvalheim et al.	6,158,915 A	12/2000	Kise
3,696,575 A	10/1972	Armstrong	6,219,982 B1	4/2001	Eyring
3,745,726 A	7/1973	Thom	6,230,385 B1	5/2001	Nelson
3,758,650 A	9/1973	Hurst	6,253,514 B1	7/2001	Jobe et al.
3,760,544 A	9/1973	Hawes et al.	6,345,480 B1	2/2002	Kemper
3,810,707 A	5/1974	Tungseth et al.	6,421,970 B1	7/2002	Martensson et al.
D240,221 S *	6/1976	Hinze ..... D25/119	6,517,935 B1	2/2003	Kornfalt
4,067,155 A	1/1978	Ruff et al.	6,560,944 B1 *	5/2003	Wilson ..... 52/717.01
4,198,455 A	4/1980	Spiro et al.	6,588,165 B1	7/2003	Wright
4,292,774 A	10/1981	Mairle	2002/0127374 A1	9/2002	Spratling
4,455,803 A	6/1984	Kornberger	2002/0148551 A1	10/2002	Knauseder
4,461,131 A	7/1984	Pressell	2002/0189747 A1	12/2002	Steinwender
4,504,347 A	3/1985	Munk et al.	2003/0118812 A1	6/2003	Kornfalt et al.
4,520,062 A	5/1985	Ungar et al.	2003/0154678 A1	8/2003	Stanchfield
4,643,237 A	2/1987	Rosa	2003/0159389 A1	8/2003	Kornfalt et al.
5,034,272 A	7/1991	Lindgren et al.	2004/0031226 A1	2/2004	Miller et al.
5,074,089 A	12/1991	Kemmer et al.	2004/0031227 A1	2/2004	Knauseder
5,155,952 A	10/1992	Herwegh et al.	2004/0041225 A1	3/2004	Nemoto

\* cited by examiner

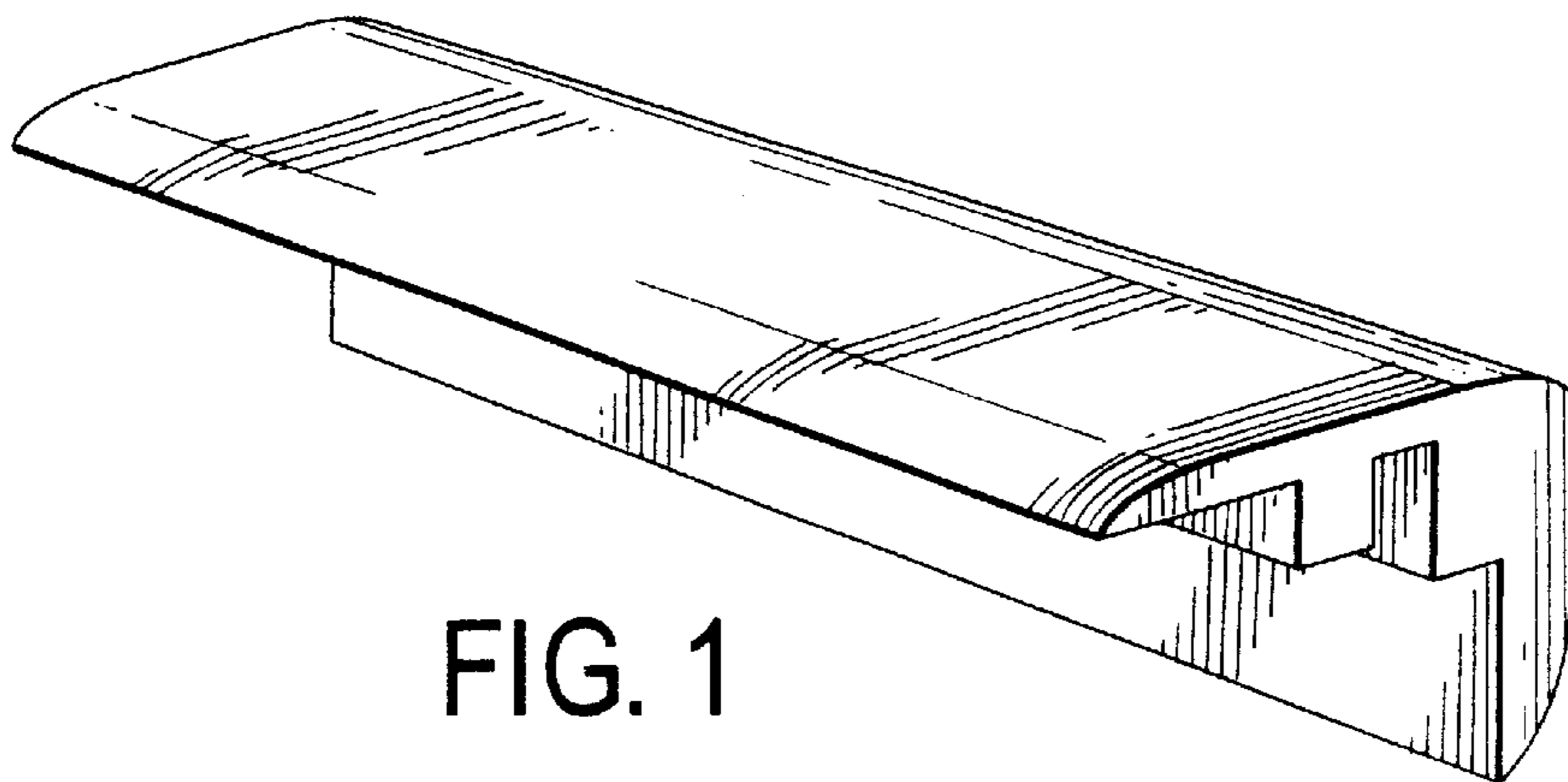

FIG. 1

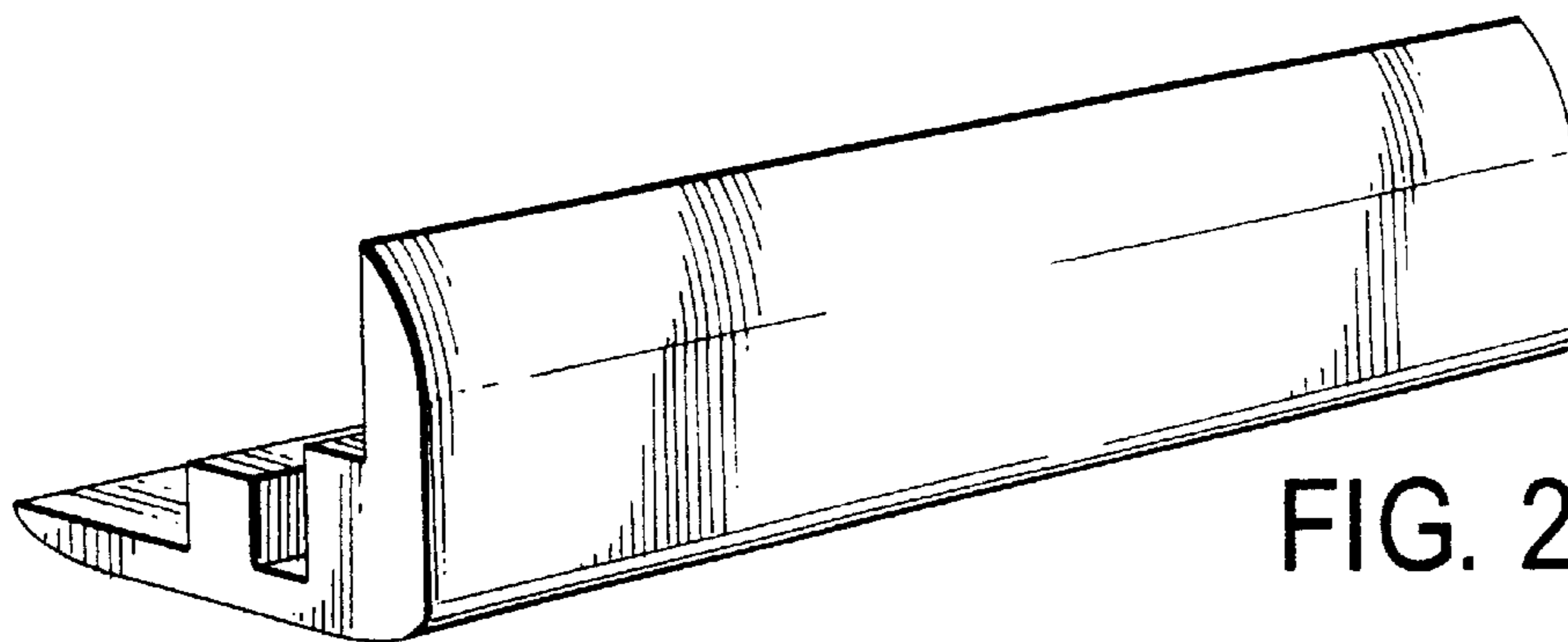

FIG. 2

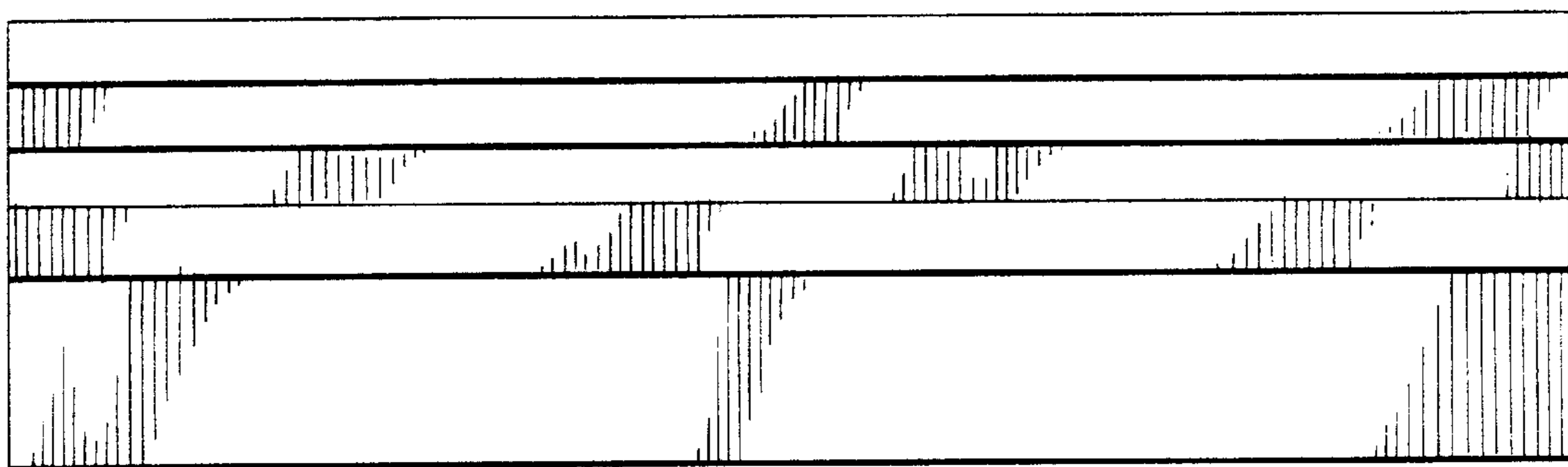

FIG. 3

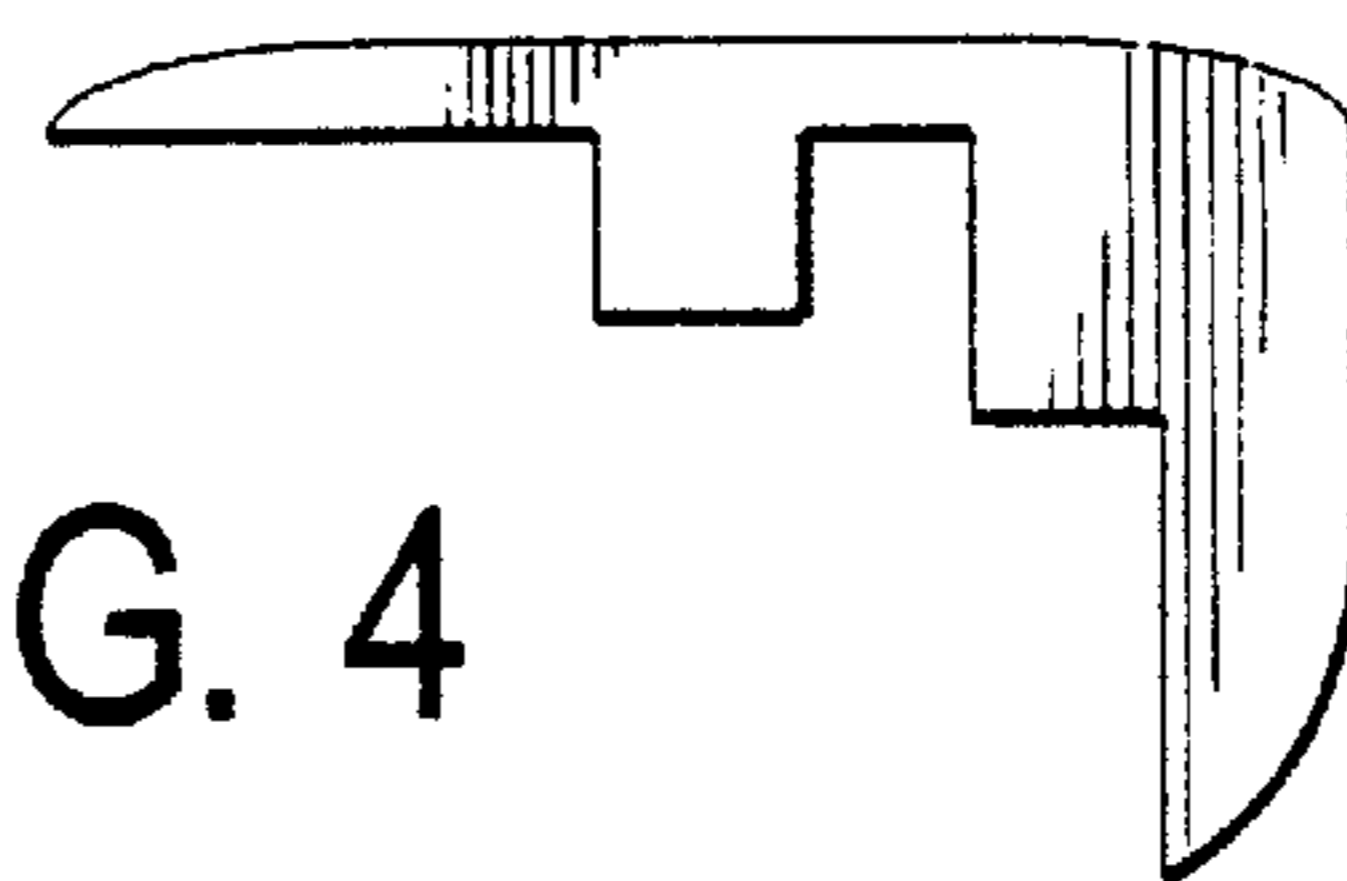

FIG. 4