

US00D505098S

(12) **United States Design Patent** (10) **Patent No.:** **US D505,098 S**
McGaughy (45) **Date of Patent:** **** May 17, 2005**

(54) **DROP SPINDLE**

(76) Inventor: **Mike McGaughy**, 5680 W. Barstow Ave., Fresno, CA (US) 93722

(**) Term: **14 Years**

(21) Appl. No.: **29/202,605**

(22) Filed: **Mar. 31, 2004**

(51) **LOC (7) Cl.** **12-16**

(52) **U.S. Cl.** **D12/160**

(58) **Field of Search** D12/159-160,
D12/400, 177; 280/93.511, 93.512, 86.75,
86.751, 124.138, 124.136

(56) **References Cited**

U.S. PATENT DOCUMENTS

2,227,521	A	1/1941	Utz	
3,749,415	A	7/1973	Sampatacos	
3,865,394	A	2/1975	Epner et al.	
D246,451	S	* 11/1977	Shealy	D12/160
4,618,159	A	10/1986	Kozyra et al.	
4,722,540	A	2/1988	Kozyra et al.	
4,953,894	A	9/1990	Broszat et al.	
5,022,673	A	6/1991	Sekino et al.	
D341,560	S	* 11/1993	Fabris et al.	D12/160
D344,254	S	* 2/1994	Zimmerman	D12/159
5,951,030	A	9/1999	Butler	
6,179,308	B1	1/2001	Mielauskas et al.	
6,394,472	B1	* 5/2002	Graf et al.	280/93.512
6,398,240	B1	6/2002	Taylor	
6,431,569	B2	8/2002	Handa	
6,729,633	B1	5/2004	Irwin	
D495,278	S	* 8/2004	Kroeker et al.	D12/159
2004/0108674	A1	6/2004	McGaughy	

OTHER PUBLICATIONS

Bell Tech, Inc., "Nobody drops 'em like Bell Tech . . .," Bell Tech, Inc., 152 M Street, Fresno, CA, 93721, Telephone No. 209-445-1602, Dec. 5, 1988, 4 pages total.

Bell Tech, Inc., "Sport Trucks—From The Ground Down," Belltech Catalog (1989), 2885 So. Chestnut, Fresno, CA, 93725, Telephone No. 209-445-1602, 4 pages total.

Bell Tech, Inc., Belltech Products Catalog (1996), 2822 E. California Avenue, Fresno, CA, 93721, Telephone No. 209-445-1602, 36 pages total.

Advertisement from *Sport Truck* magazine (1992) 2822 E. California Ave., Fresno, CA, 93721, Telephone No. 209-445-1602, 3 pages total.

Bell Tech, Inc., "2001 Belltech Application Guide," 2822 E. California Ave., Fresno, CA, 93721, Telephone No. 559-445-1602, www.belltechcorp.com, 20 pages total.

Bell Tech, Inc., "Belltech Sport Trucks—Application Guide," (2003) 2822 E. California Ave., Fresno, CA, 93721, Telephone No. 559-445-1602, www.belltechcorp.com, 20 pages total.

* cited by examiner

Primary Examiner—Stacia Cadmus

(74) *Attorney, Agent, or Firm*—Townsend & Townsend & Crew LLP; Nathan S. Cassell

(57) **CLAIM**

The ornamental design for a drop spindle, as shown and described.

DESCRIPTION

The claimed drop spindle is used to lower the chassis of a vehicle.

FIG. 1 is a perspective view of a drop spindle showing my new design;

FIG. 2 is a top plan view thereof;

FIG. 3 is a front elevational view thereof;

FIG. 4 is a right side elevational view thereof;

FIG. 5 is a left side elevational view thereof;

FIG. 6 is a rear elevational view thereof; and,

FIG. 7 is a bottom plan view thereof.

1 Claim, 7 Drawing Sheets

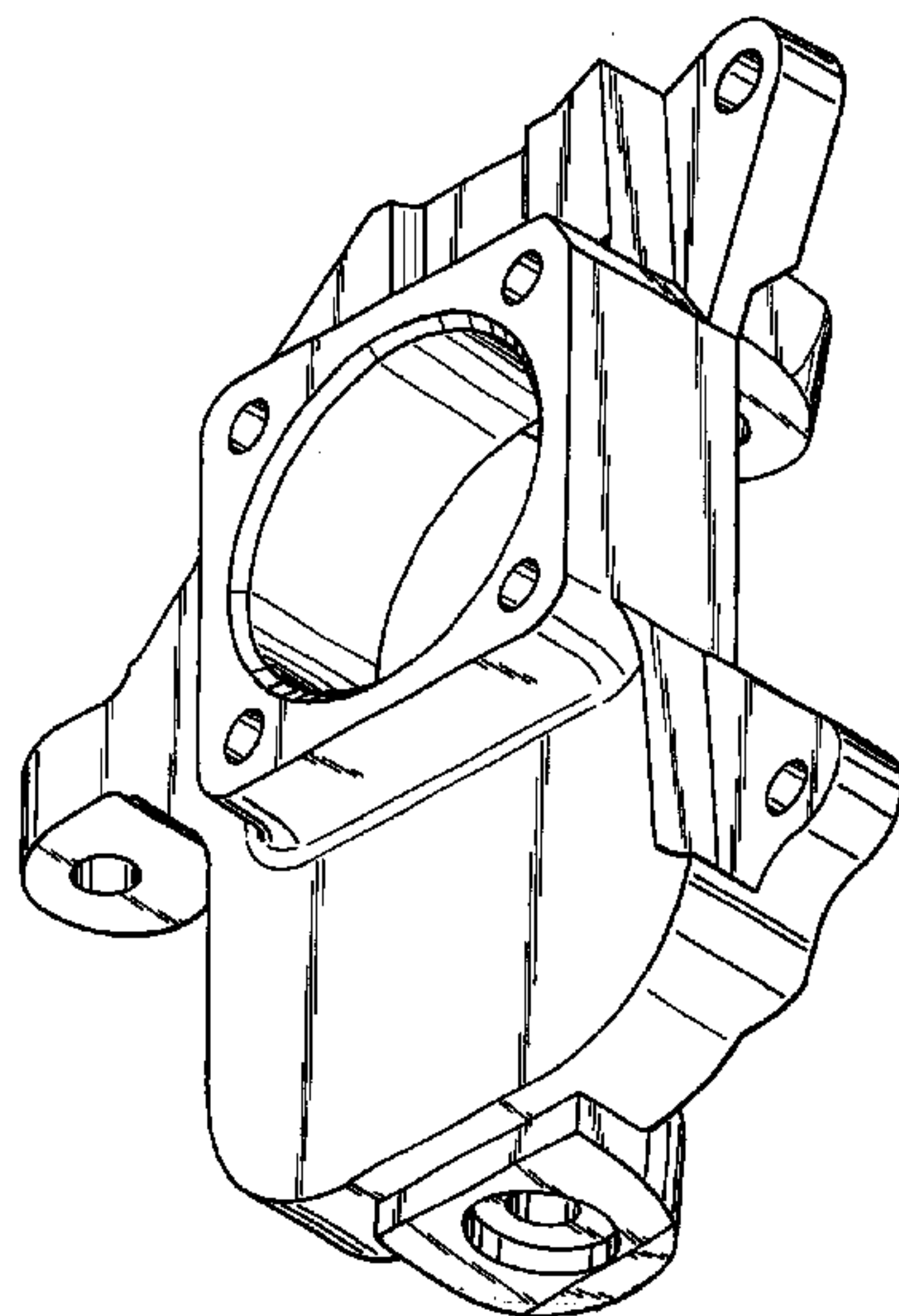

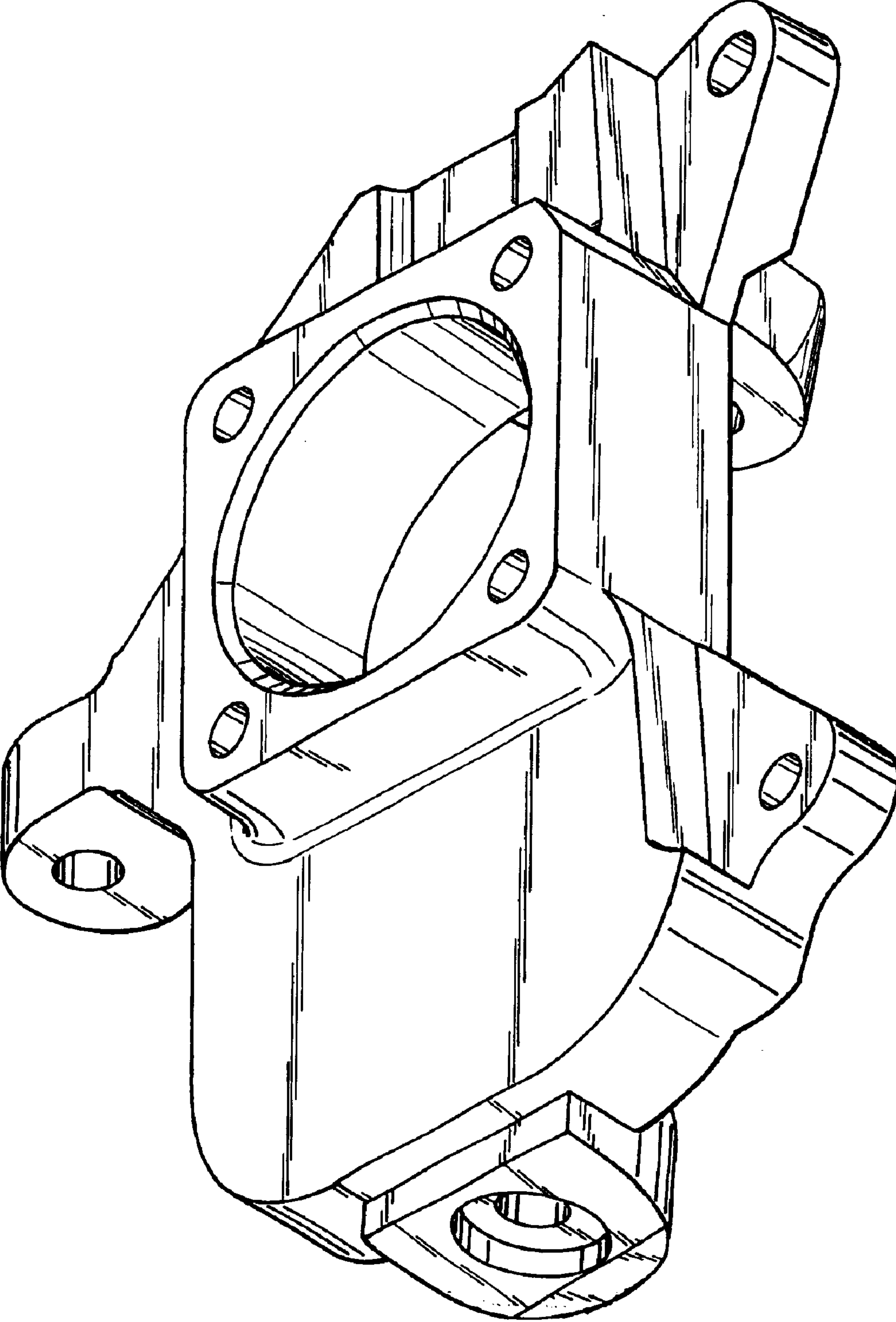

FIG. 1

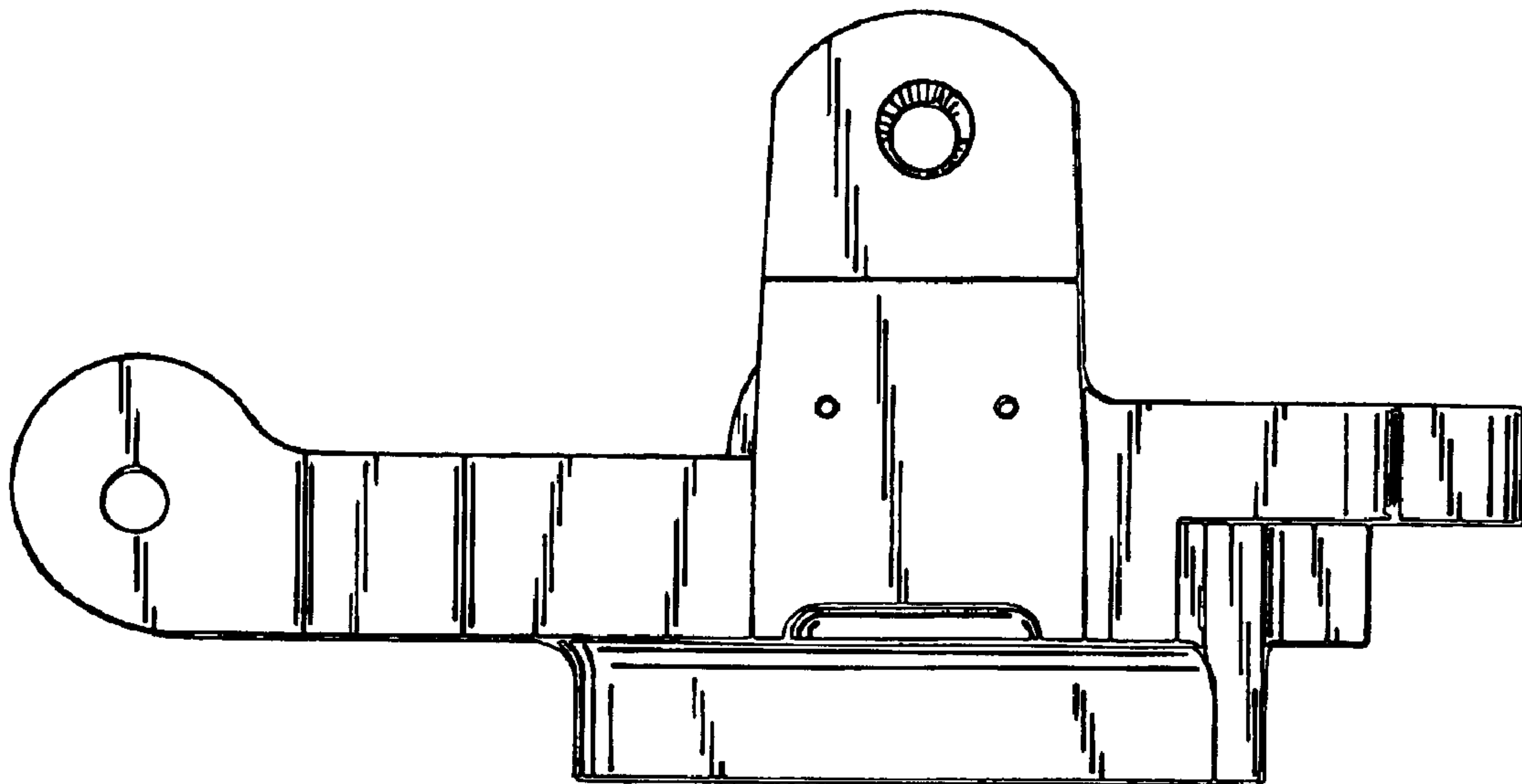

FIG. 2

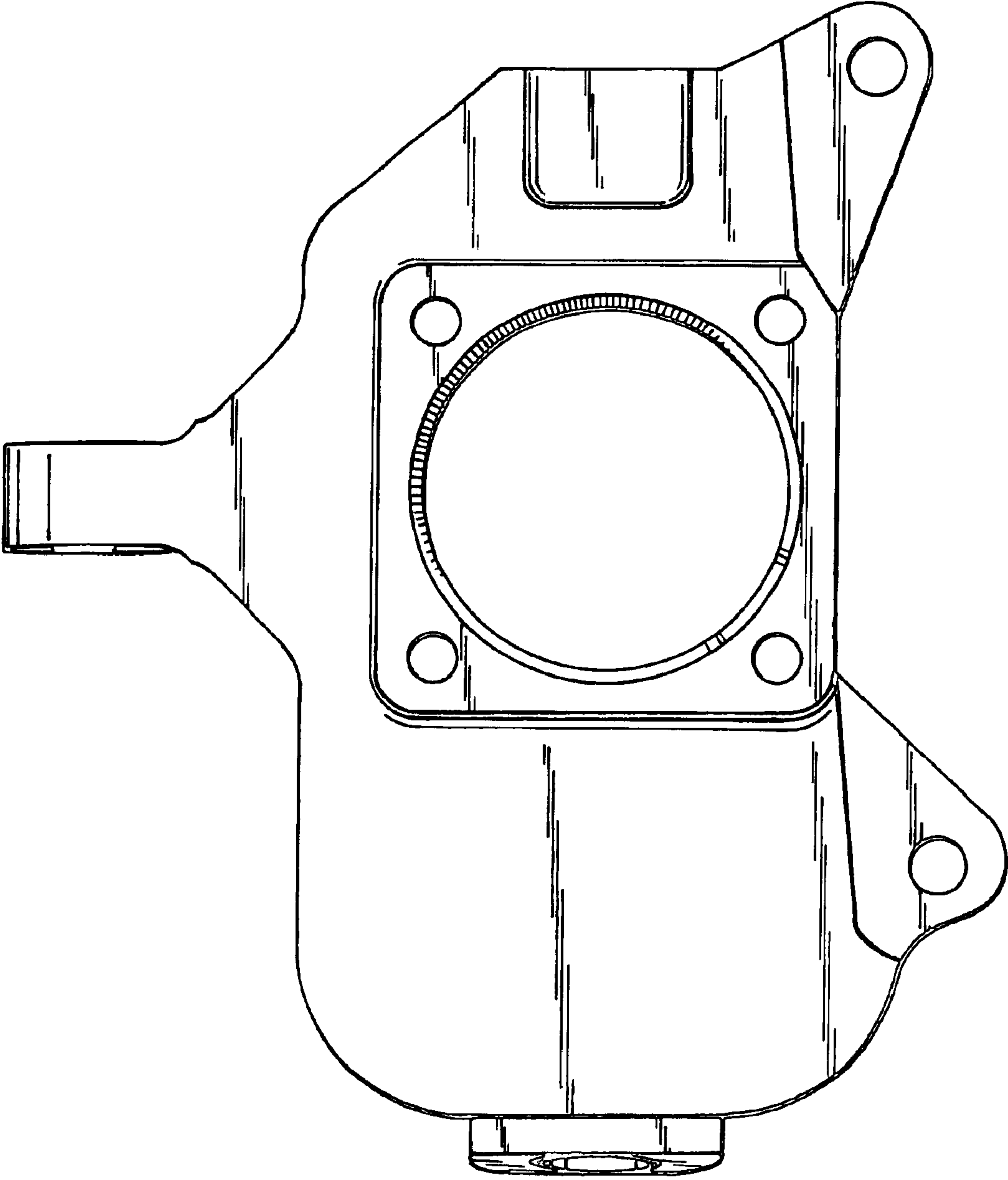

FIG. 3

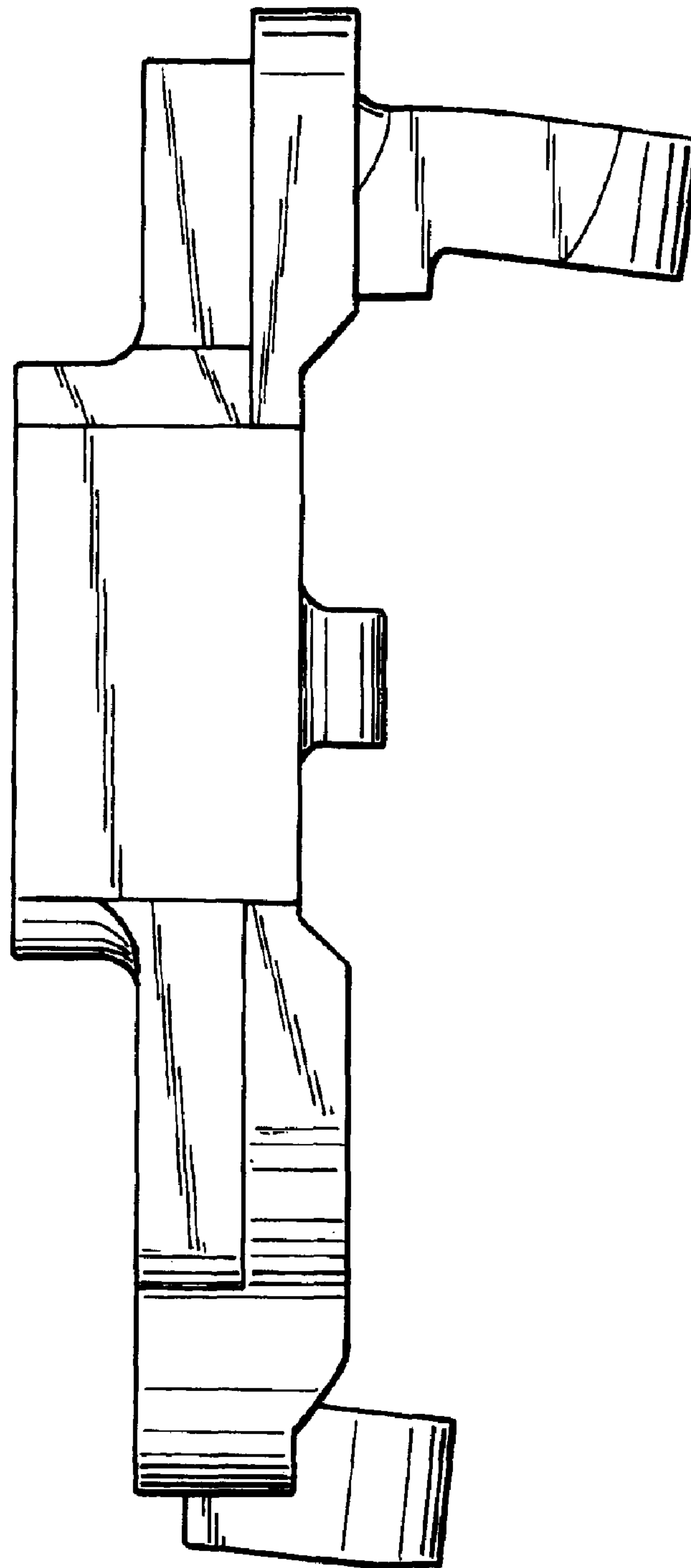

FIG. 4

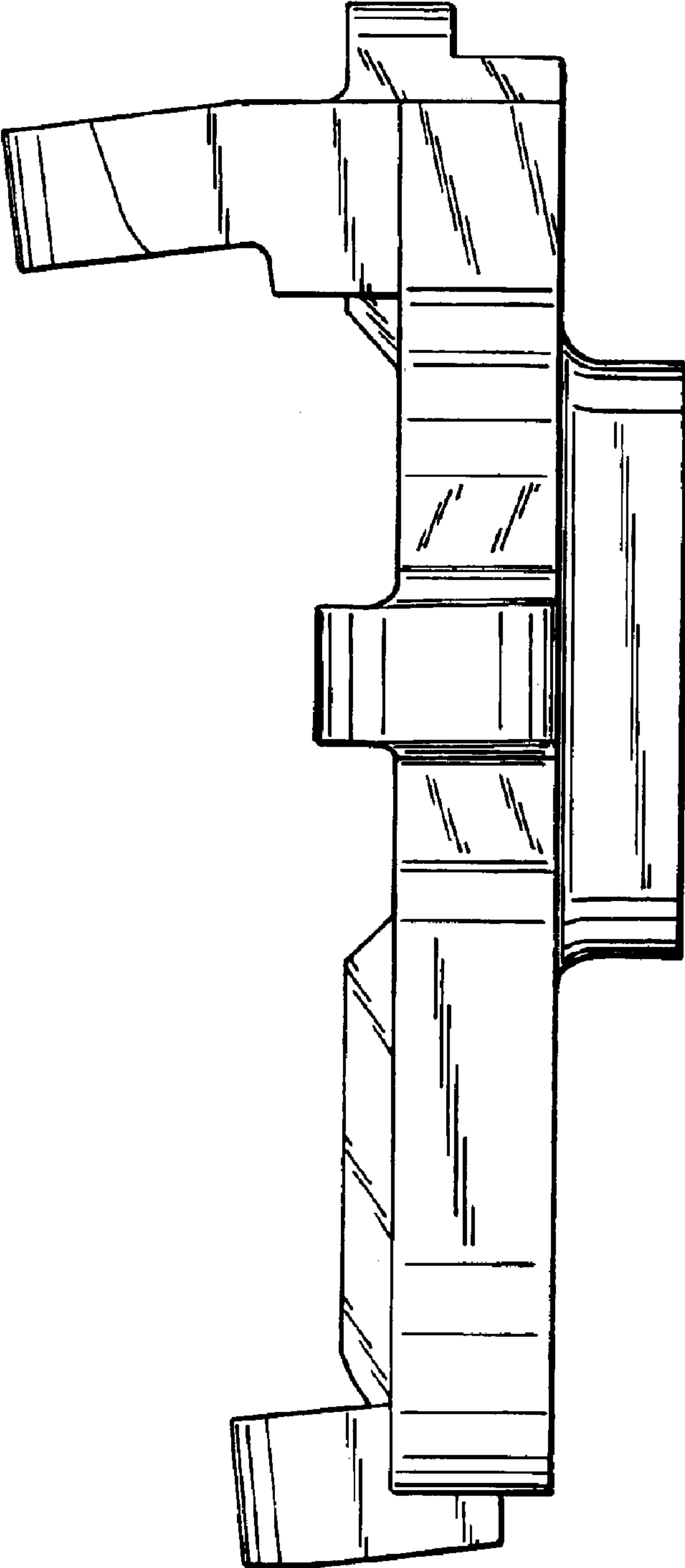

FIG. 5

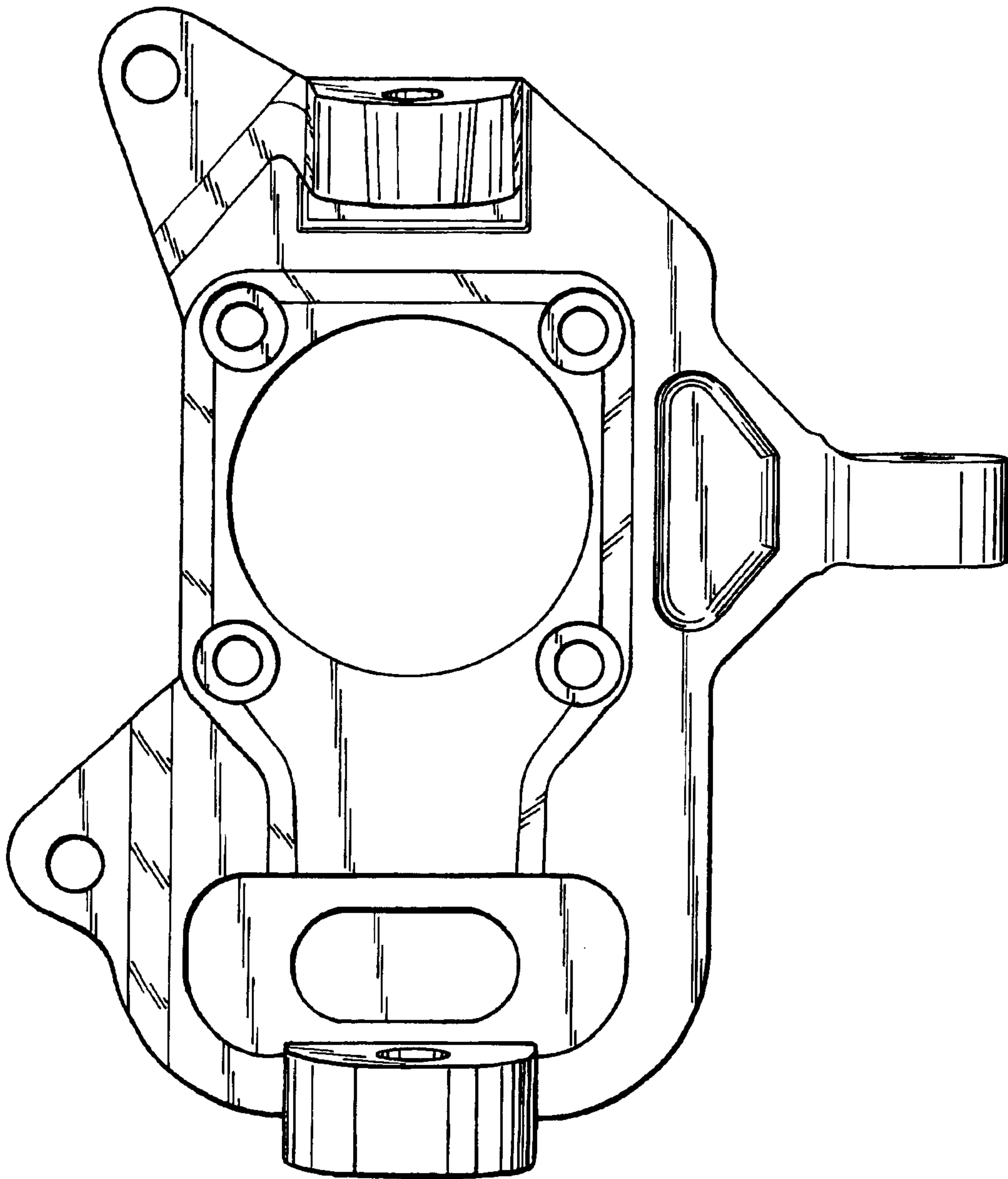

FIG. 6

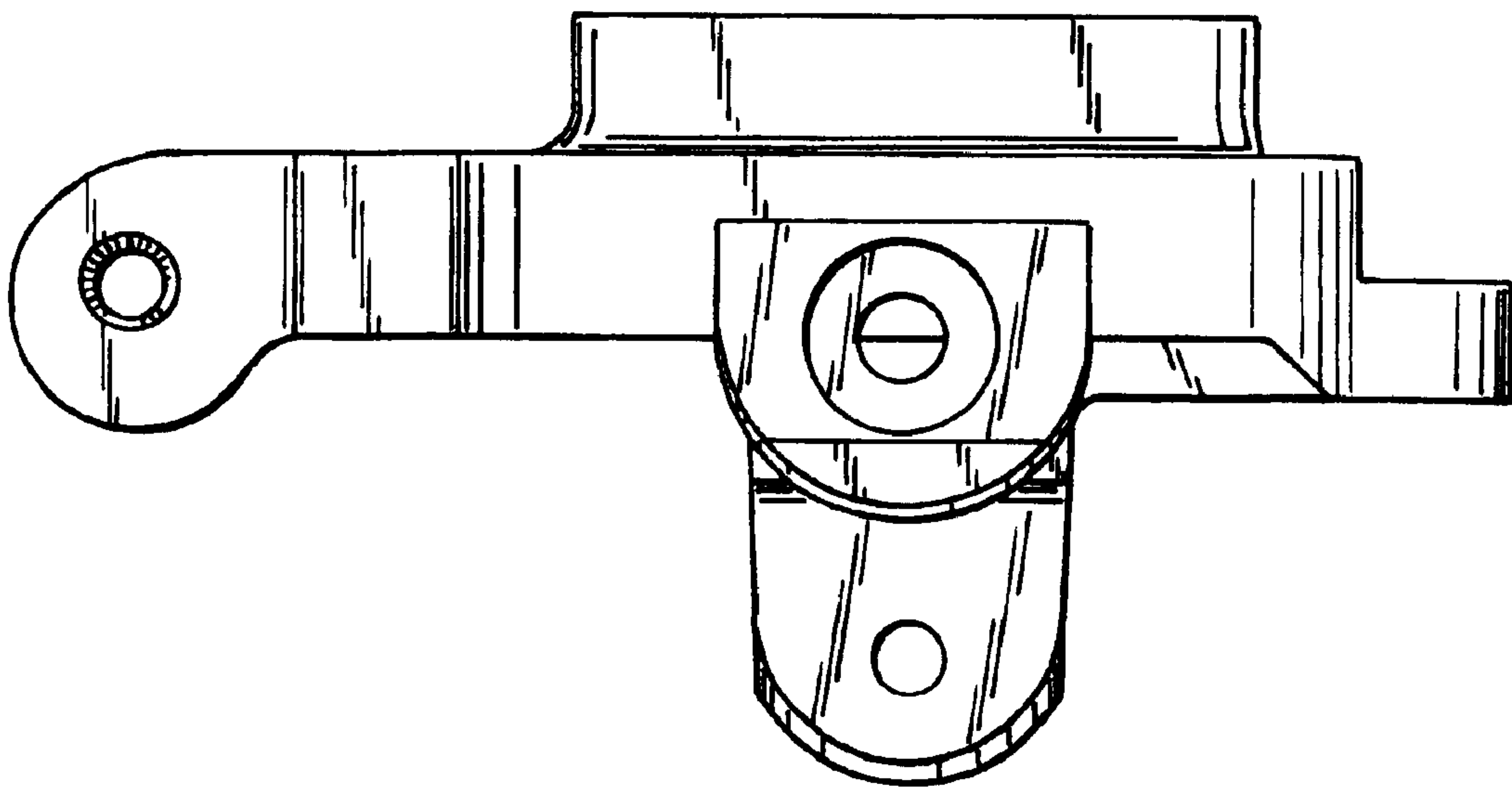

FIG. 7