



US00D504943S

(12) **United States Design Patent**
Dudley

(10) **Patent No.:** **US D504,943 S**
(45) **Date of Patent:** **** May 10, 2005**

- (54) **VEHICLE AIR FILTER HOUSING**
- (75) Inventor: **Lynn A. Dudley**, Chino, CA (US)
- (73) Assignee: **Vortox Company**, Claremont, CA (US)
- (**) Term: **14 Years**
- (21) Appl. No.: **29/213,831**
- (22) Filed: **Sep. 22, 2004**

6,426,930 B2 * 7/2002 Tanaka et al. 369/59.12

* cited by examiner

Primary Examiner—Robin V. Taylor
(74) *Attorney, Agent, or Firm*—Boniard I. Brown

(57) **CLAIM**

The ornamental design for a vehicle air filter housing, as shown and described.

DESCRIPTION

FIG. 1 is a perspective view of a vehicle air filter housing, wherein air intake openings are defined in the upper cap portion thereof;
 FIG. 2 is a perspective view of the filter of FIG. 1 opposite from the view of FIG. 1;
 FIG. 3 is an elevational view of the filter shown in FIG. 1;
 FIG. 4 is a top view of the filter of FIG. 1 wherein holes like those of FIGS. 1 and 2 are disposed in the area enclosed by broken lines;
 FIG. 5 is a bottom view thereof; and,
 FIG. 6 is an enlarged view of an area defined by circle 6 in FIG. 4, showing a pattern of holes defined in the area by broken lines in FIG. 4.

The broken line showing is for illustrative purposes only and forms no part of the claimed design.

Related U.S. Application Data

- (62) Division of application No. 29/194,326, filed on Nov. 21, 2003, now Pat. No. Des. 496,720, which is a division of application No. 29/162,143, filed on Jun. 11, 2002, now Pat. No. Des. 482,767.
- (51) **LOC (7) Cl.** **23-04**
- (52) **U.S. Cl.** **D23/365; D15/5**
- (58) **Field of Search** **D23/365; D15/5;**
55/DIG. 28, 385.3; 454/156, 158

(56) **References Cited**

U.S. PATENT DOCUMENTS

- 4,326,865 A * 4/1982 Siebels 55/385.3
- D283,621 S * 4/1986 Gauer et al. D15/5
- D403,024 S * 12/1998 Muraki et al. D21/326
- 6,379,410 B1 * 4/2002 Dudley 55/385.3

1 Claim, 2 Drawing Sheets

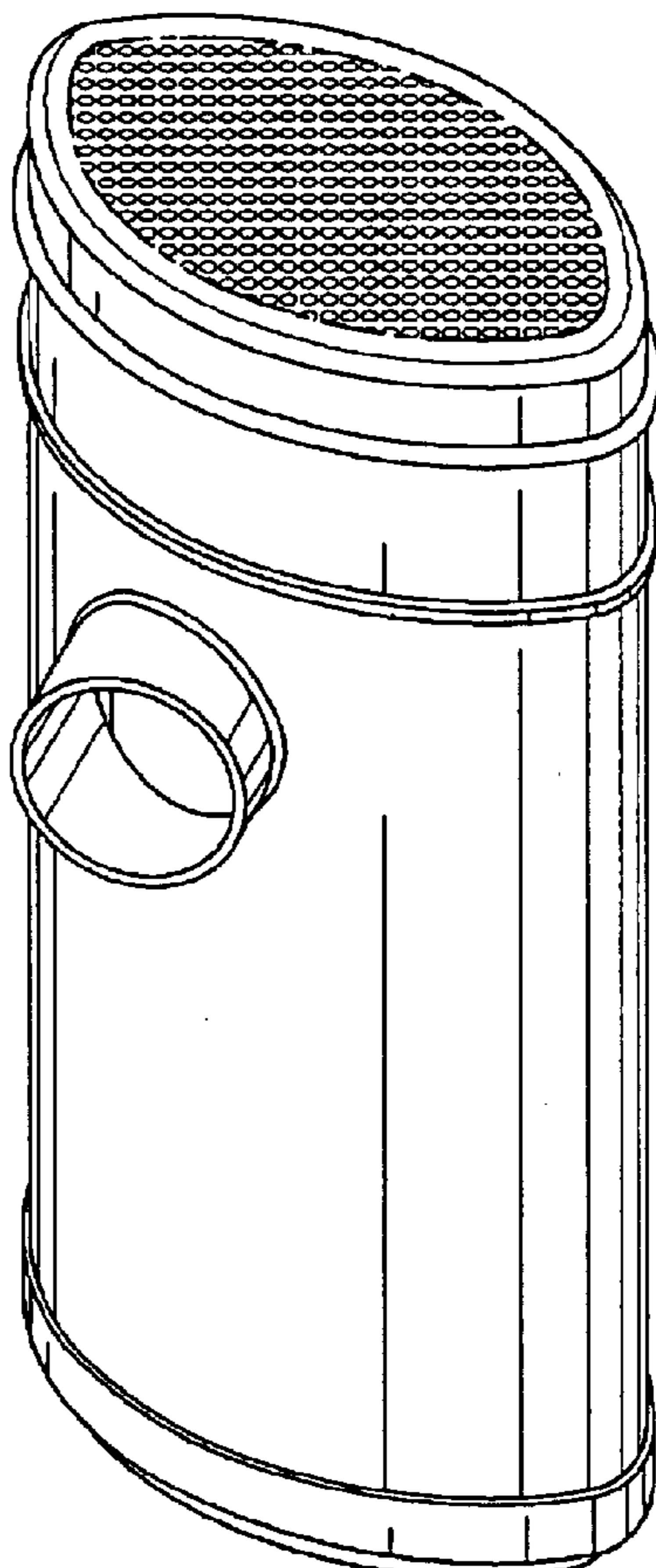

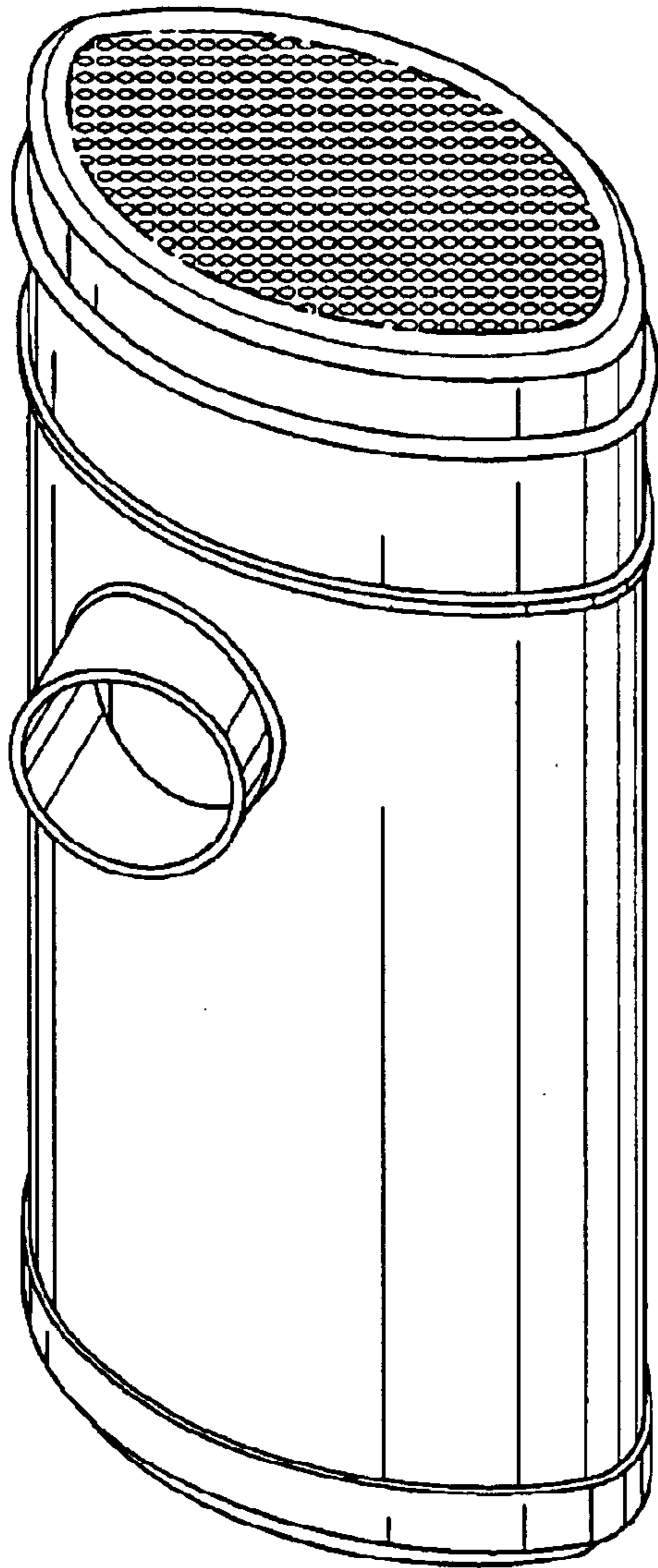

FIG. 1

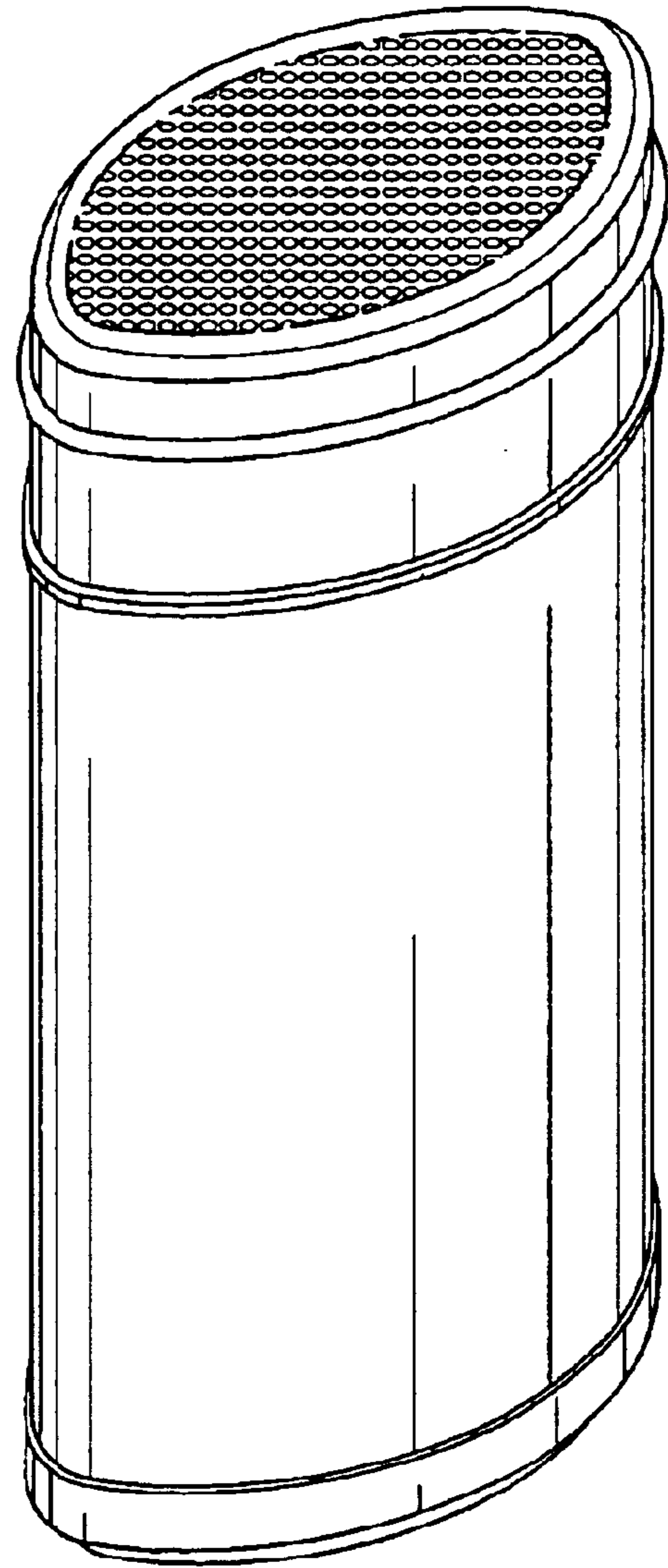

FIG. 2

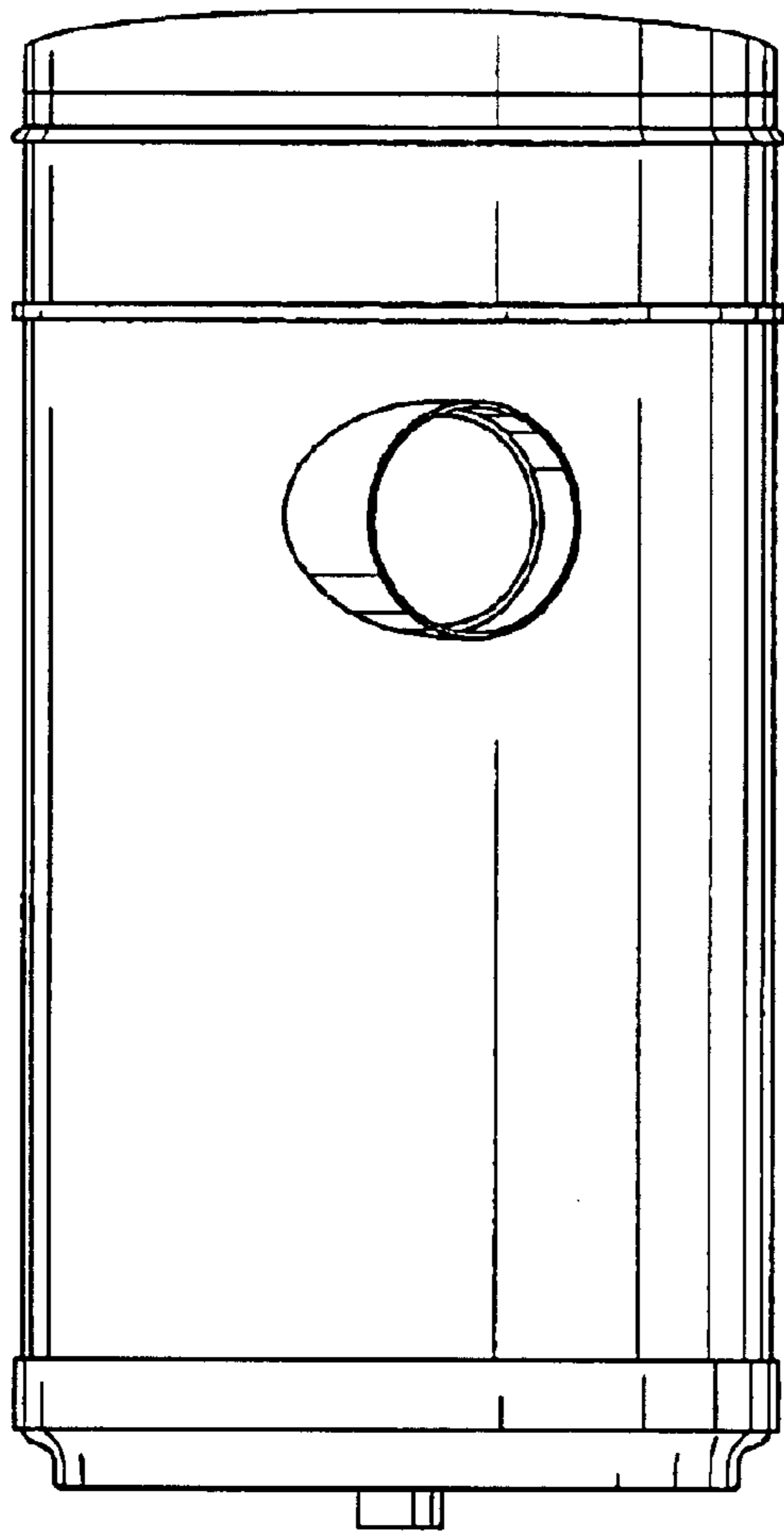

FIG. 3

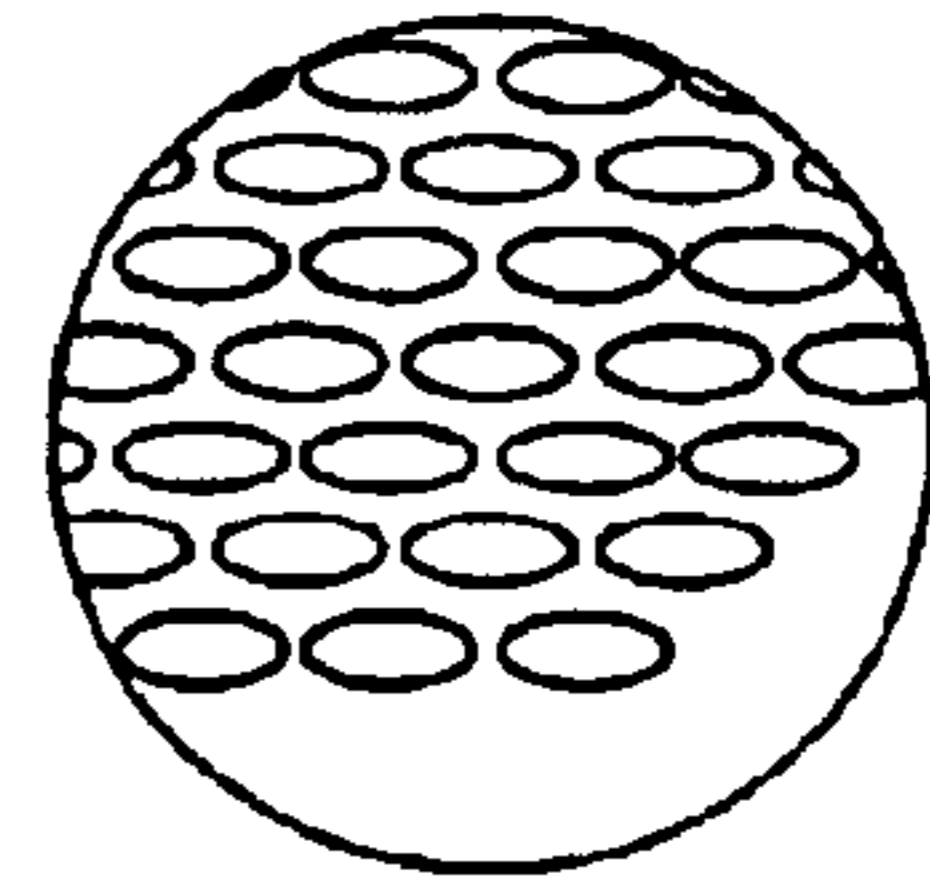

FIG. 6

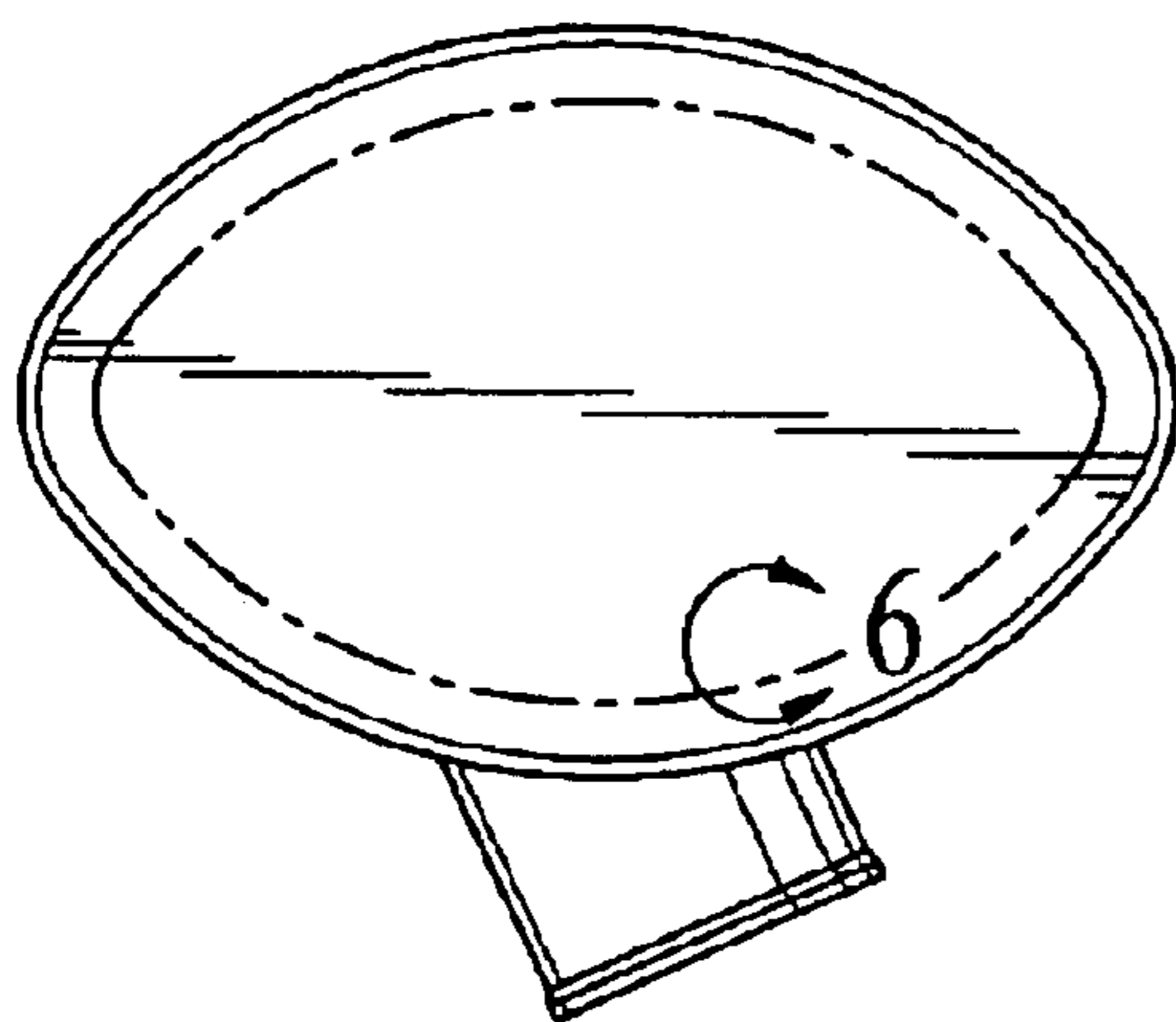

FIG. 4

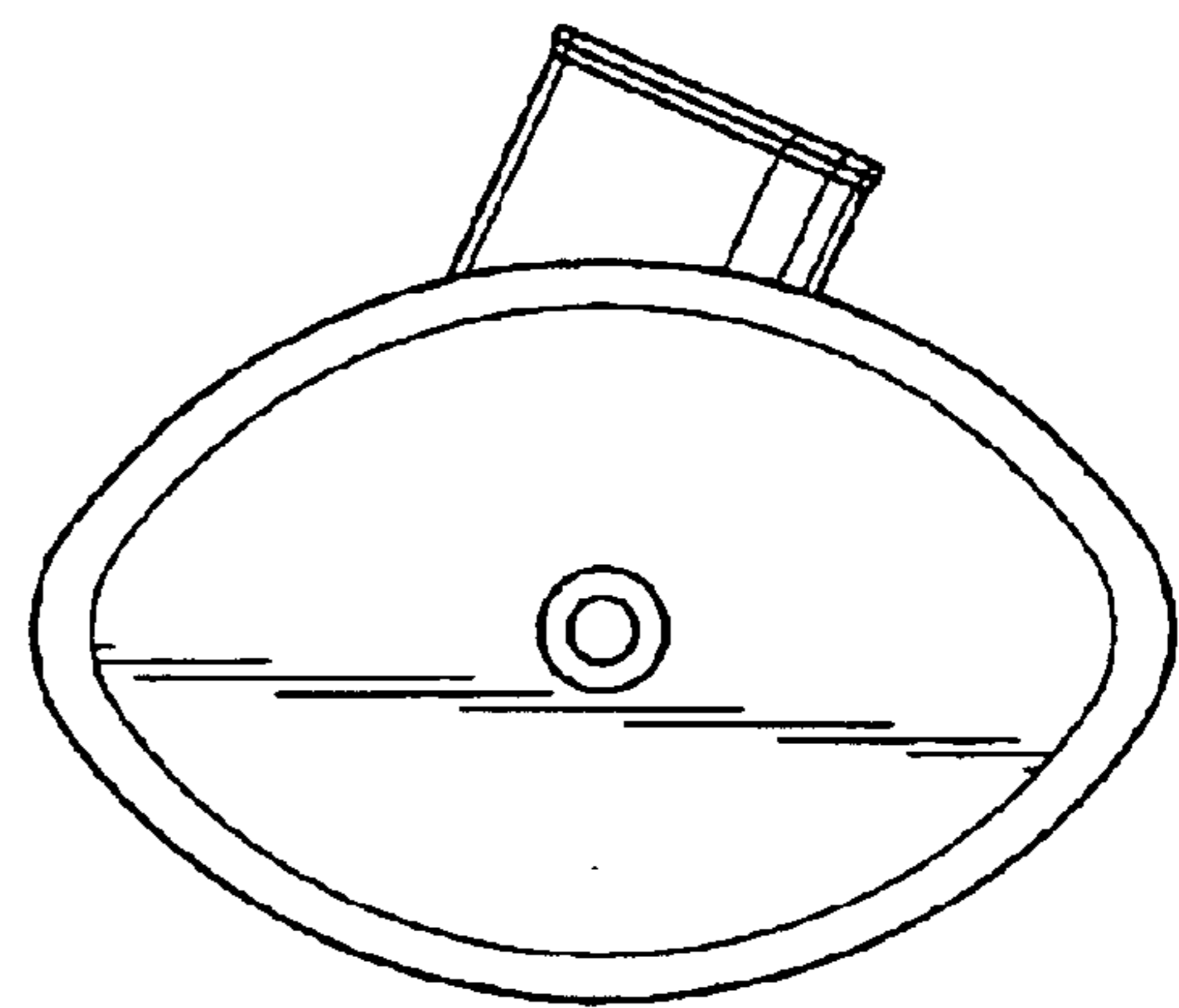

FIG. 5