



US00D504883S

(12) **United States Design Patent**
Jacobson et al.

(10) **Patent No.: US D504,883 S**

(45) **Date of Patent: ** May 10, 2005**

(54) **PERSONAL AUDIO SET**

(75) Inventors: **Robert Jacobson**, Camas, WA (US);
Raymond Weikel, Camas, WA (US);
Dominic Amae, Vancouver, WA (US);
Omer Kotzer, Portland, OR (US);
Jamian Cobbett, Portland, OR (US);
Pierre Harper, Portland, OR (US)

(73) Assignee: **Logitech Europe S.A.**, Roman
el-sur-Morges (CH)

(**) Term: **14 Years**

(21) Appl. No.: **29/205,937**

(22) Filed: **May 21, 2004**

(51) **LOC (7) Cl. 14-03**

(52) **U.S. Cl. D14/192; D14/205**

(58) **Field of Search** D14/191, 192,
D14/204, 205, 223, 249, 248, 137, 138,
147, 148, 188; 381/300, 370, 309-311,
376-381; 379/430, 431, 433.01, 440

(56) **References Cited**

U.S. PATENT DOCUMENTS

- 3,984,885 A * 10/1976 Yoshimura et al. 381/309
- 4,829,571 A * 5/1989 Kakiuchi et al. 381/309
- 5,095,382 A * 3/1992 Abe 398/202
- 5,333,206 A * 7/1994 Koss 381/370
- D352,036 S * 11/1994 Sekita D14/192
- 5,369,857 A * 12/1994 Sacherman et al. 29/594

- 5,740,254 A * 4/1998 Thompson et al. 381/309
- D409,614 S * 5/1999 Carlton D14/192
- D439,574 S * 3/2001 Katayama D14/156
- D453,015 S * 1/2002 Yuyama D14/205
- D467,895 S * 12/2002 Hirano D14/192

* cited by examiner

Primary Examiner—Prabhakar Deshmukh
(74) *Attorney, Agent, or Firm*—Ipsolon, LLP.

(57) **CLAIM**

The ornamental design for a personal audio set, as shown and described.

DESCRIPTION

FIG. 1 is a front, left perspective view of the personal audio set;

FIG. 2 is a back, left perspective view thereof;

FIG. 3 is a front, elevation view thereof; the back, elevation view being a mirror image thereof;

FIG. 4 is a bottom, elevation view thereof;

FIG. 5 is a top, elevation view thereof;

FIG. 6 is a left, elevation view thereof; and,

FIG. 7 is a right, elevation view thereof.

The broken lines showing a behind-the-head headband, ear pads, a boom microphone and seams, and component openings are for illustrative purpose only and form no part of the claimed design.

The broken lines lines, which also define the bounds of the claimed design form no part thereof.

1 Claim, 2 Drawing Sheets

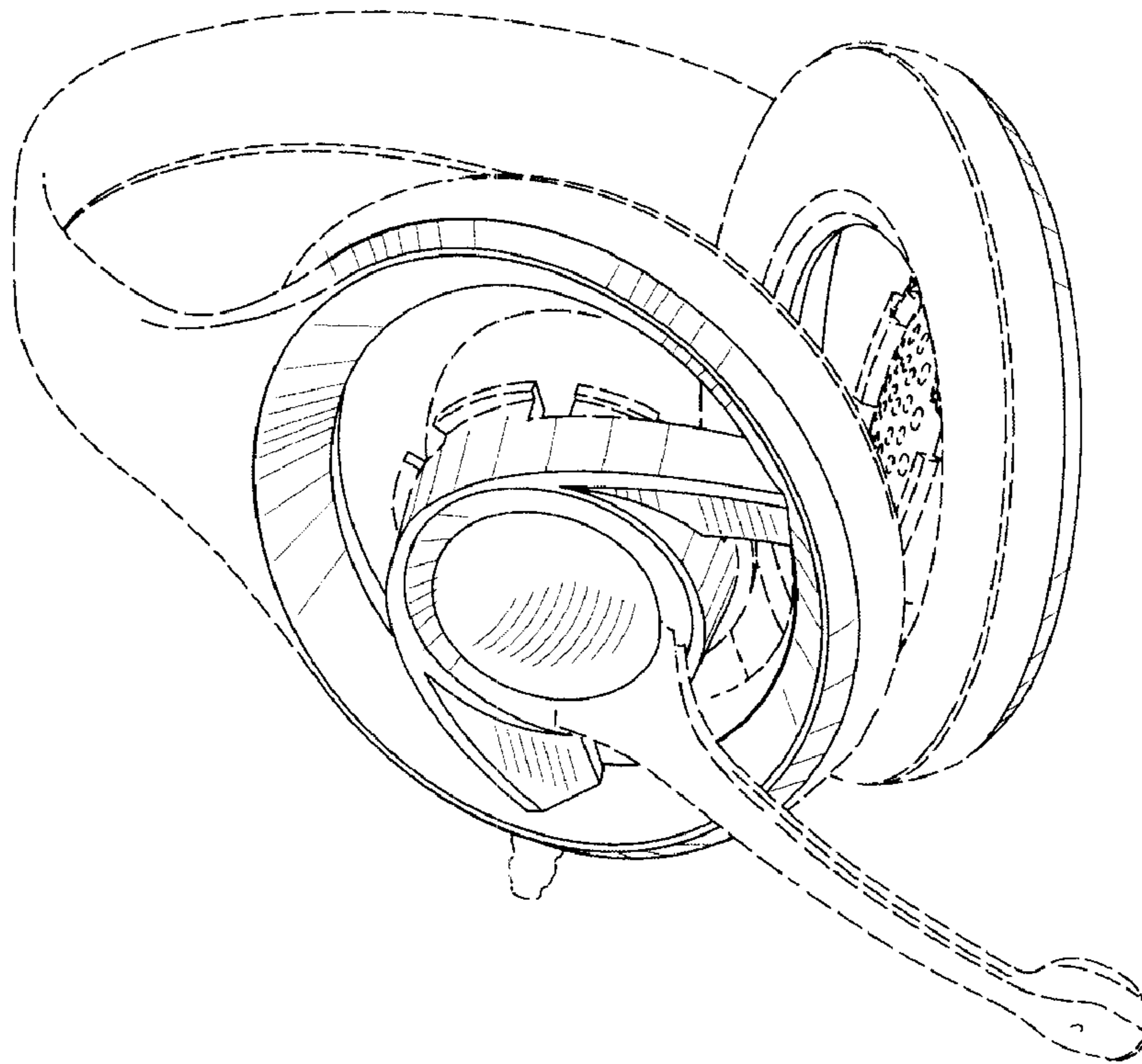

FIG. 1

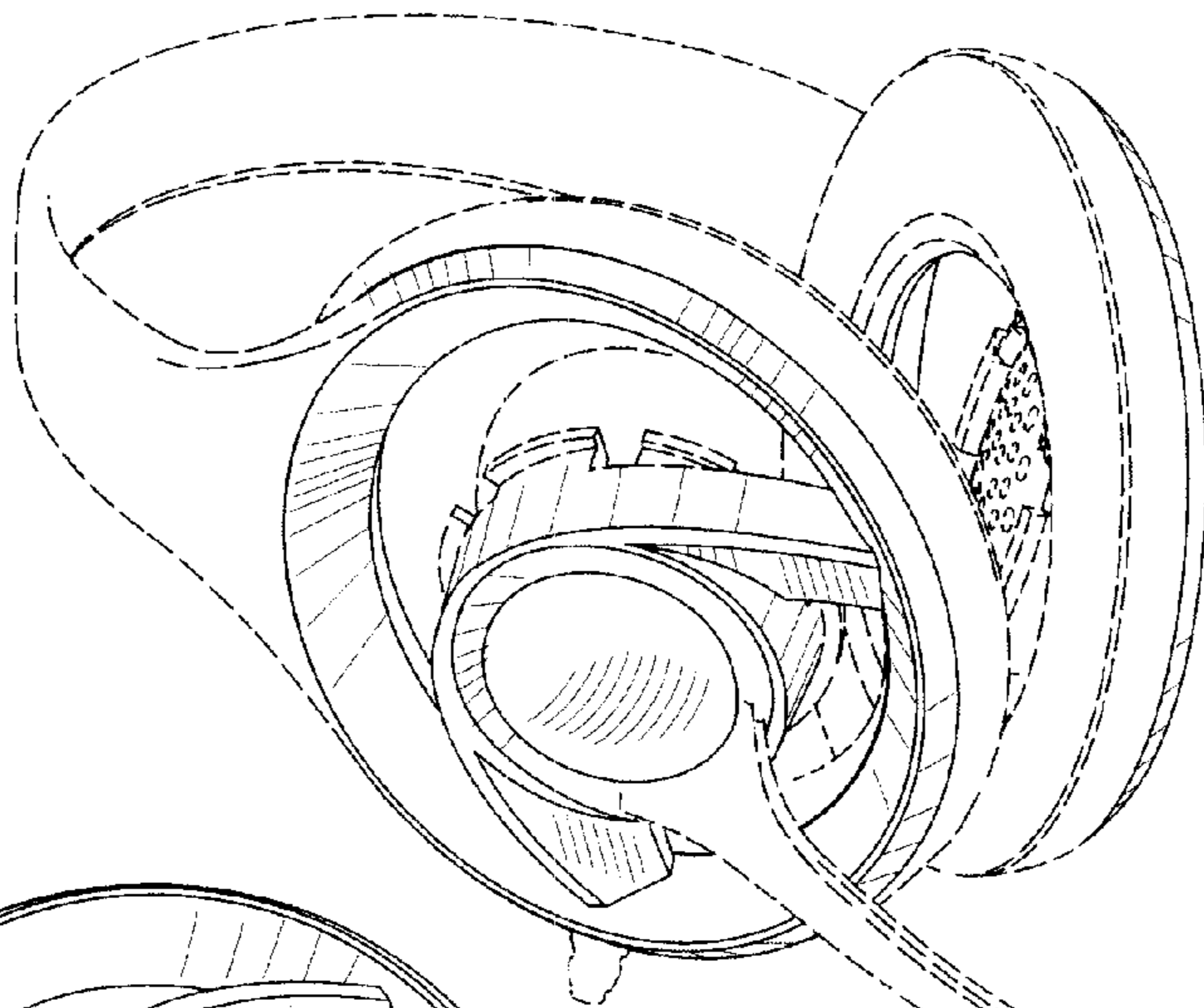

FIG. 2

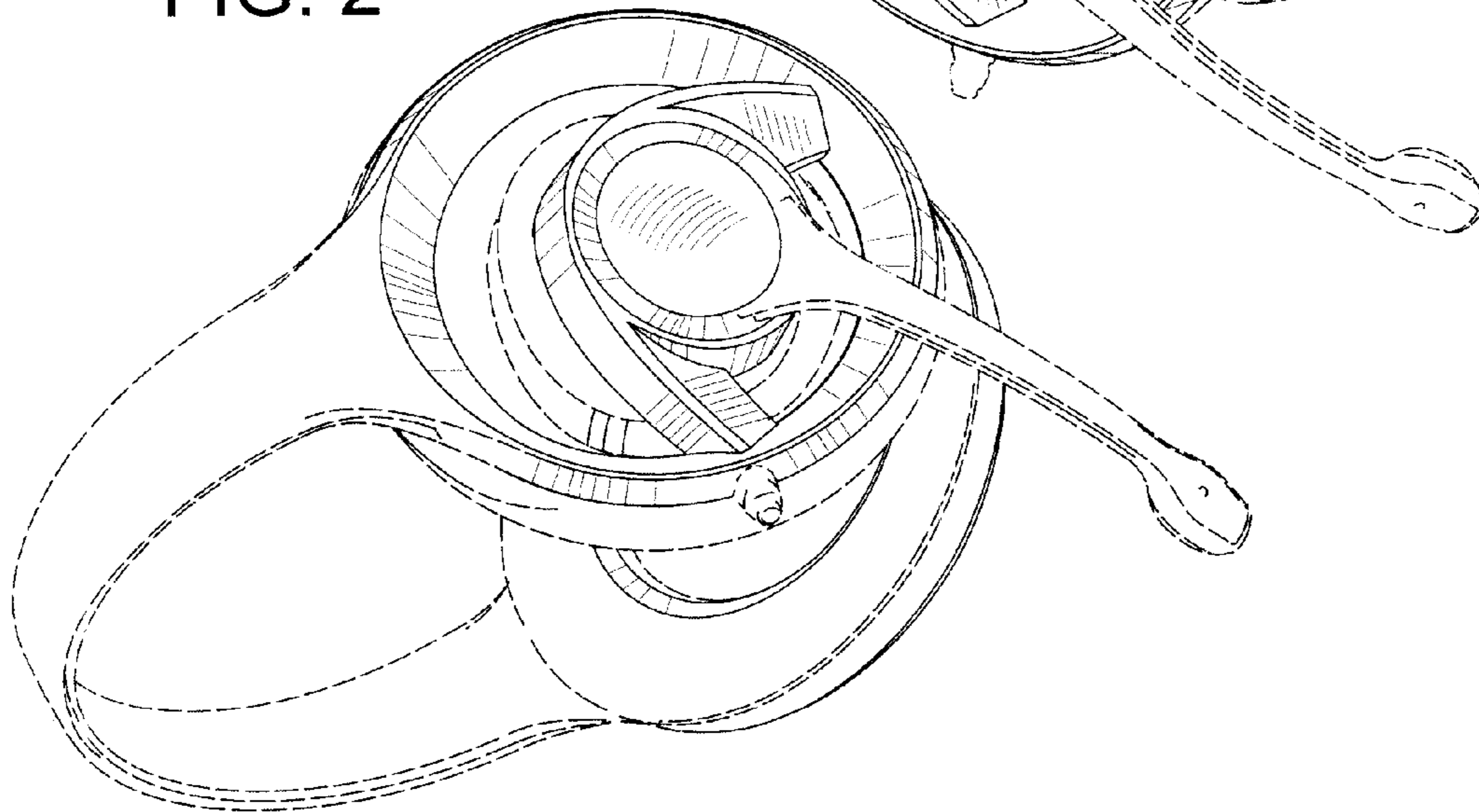
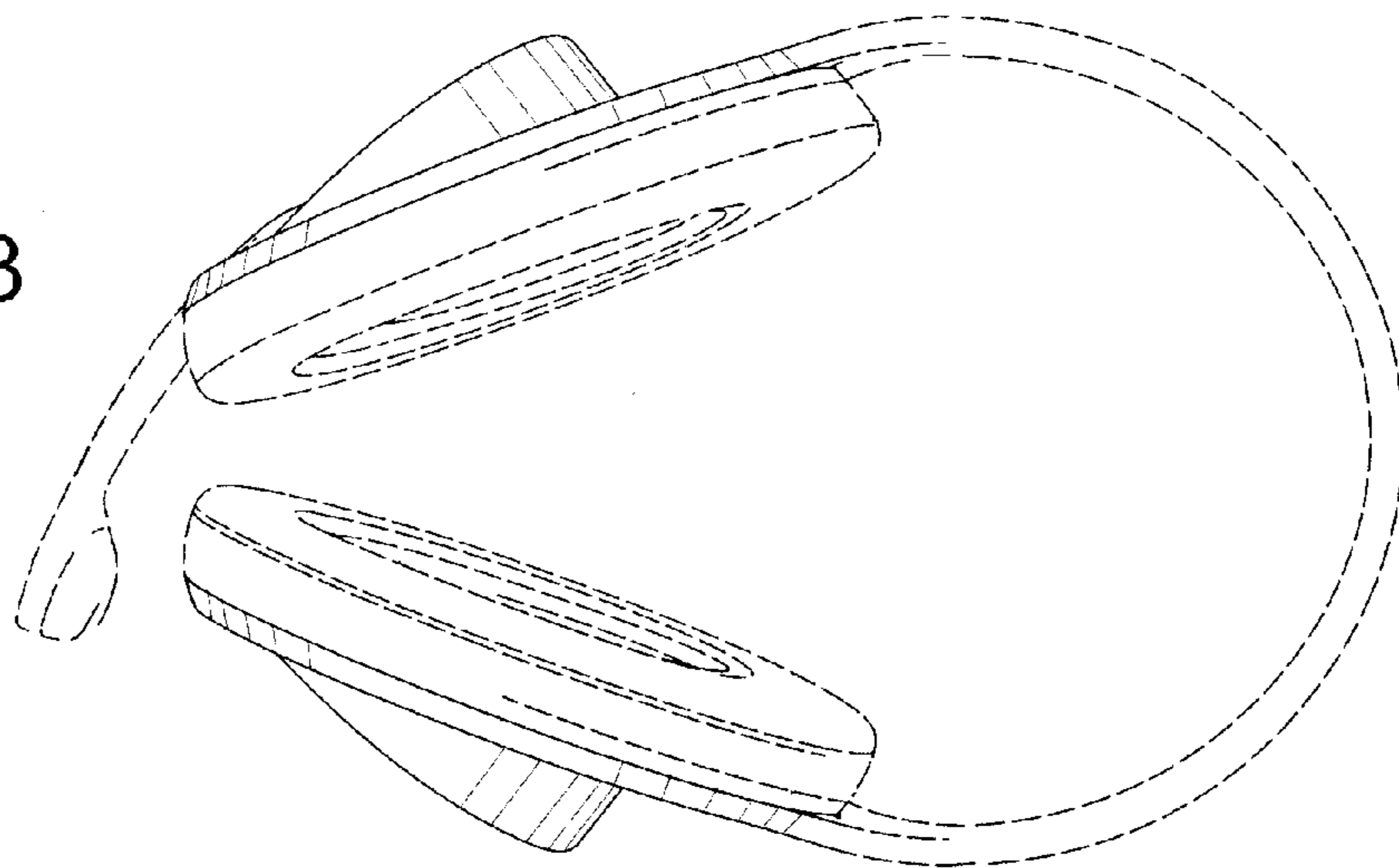

FIG. 3



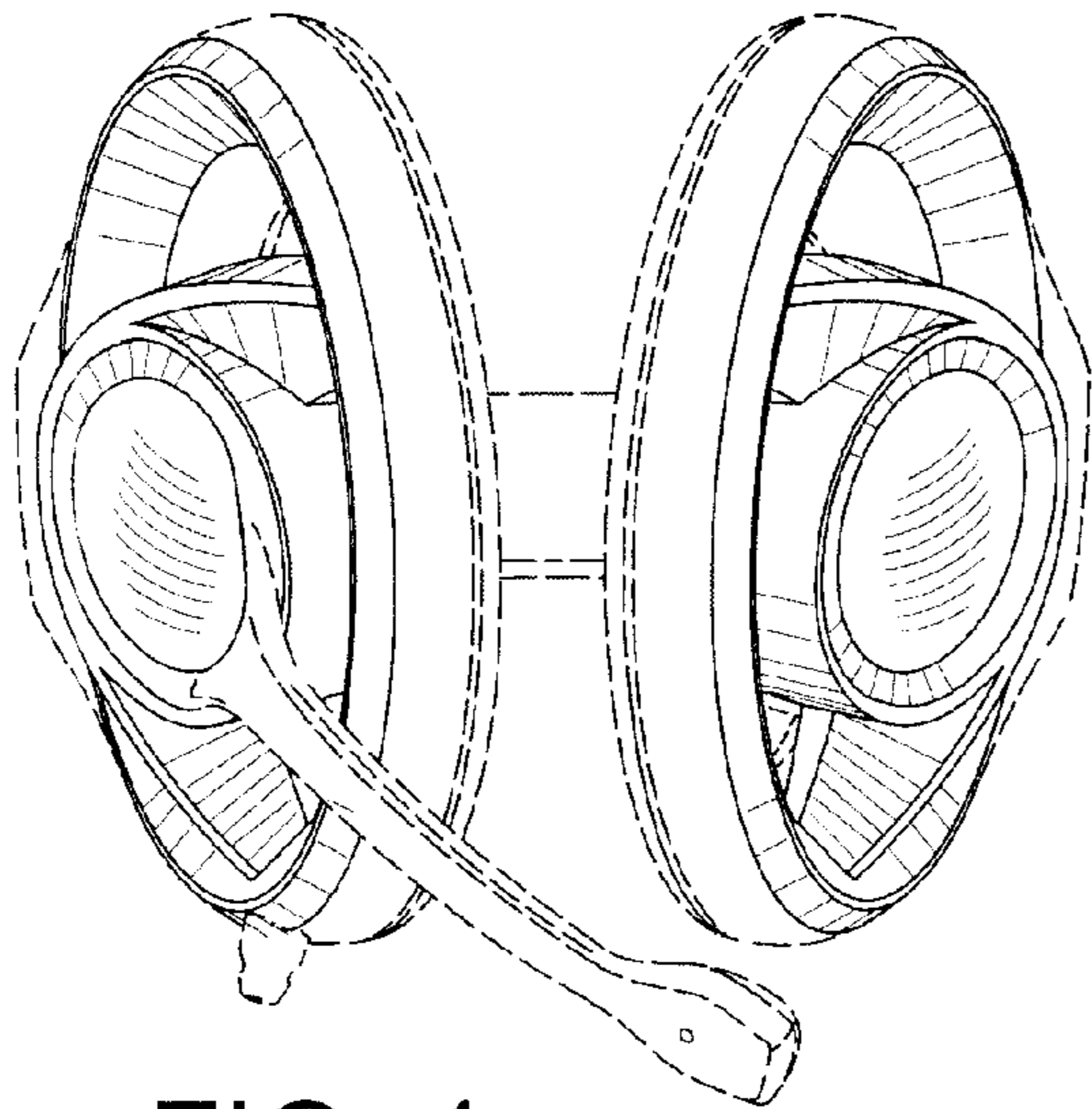

FIG. 4

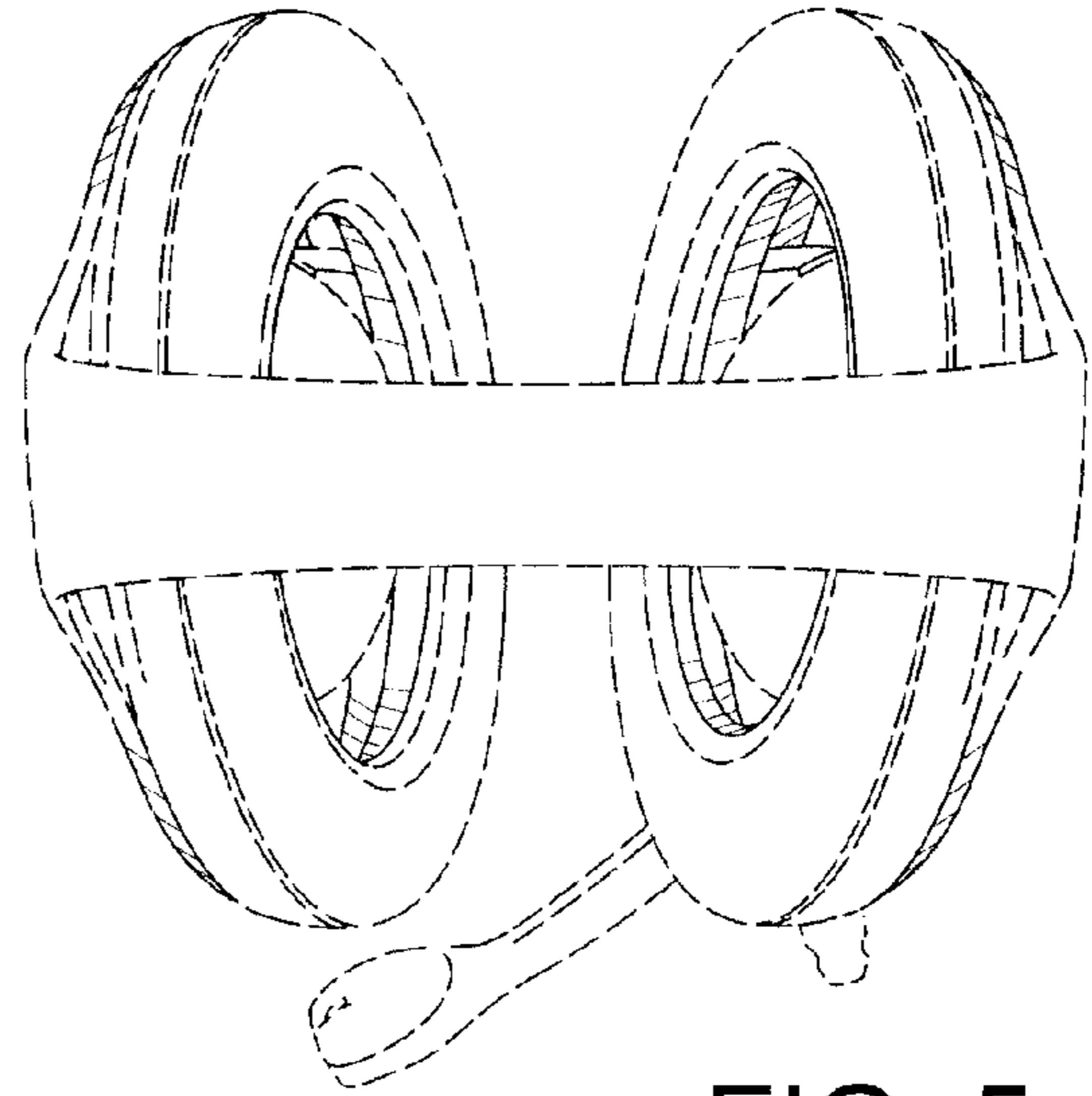

FIG. 5

FIG. 6

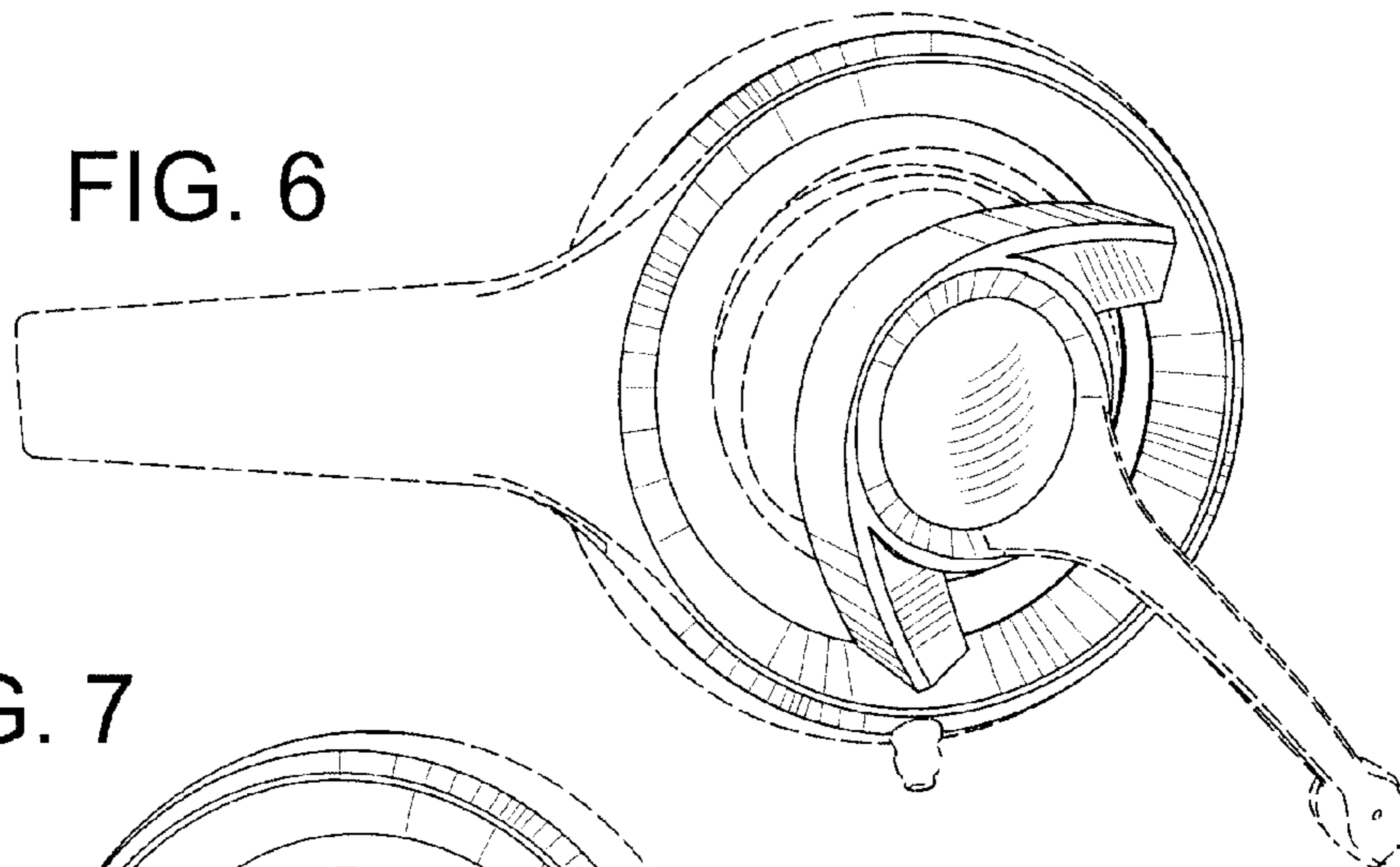

FIG. 7

